

General Specifications

μR10000
Recorder



GS 04P01B01-01E

The μR10000 is a compact recorder with a recording width of 100mm. The model family consists of 1, 2, 3, 4 pen and a 6 dot models. Pen model realizes continuous recording for each channel, whereas the 6-dot model realizes a high speed of 6 dot / 10 sec. The input is universal input. High reliability is realized by contact free technology, such as high withstand voltage semiconductor relays, and pen servo unit using an ultra-small stepping motors. The versatile display such as multi-channel digital display, bar graph display, flag display, DI/DO status display, and date/time display are provided with 101 × 16 VFD dot display.

On models with the SD memory card (/EM1) option, measured data can be saved to an SD memory card while recording on chart paper. Further, on dot models, saved data can be replayed on chart paper.

The μR10000 can be used as a monitoring device and as a quality control instrument in many applications (such as process temperature monitoring, pollution, construction, furnaces, field of medical diagnosis, field of refrigerating, etc.).

The measuring accuracies noted in the general specifications have a margin of error that takes into account the product's components and the equipment used for adjustment and testing. However, the actual values calculated from the accuracy testing data upon shipment of the instrument from the factory are as follows.

Input	Measuring Range*1 (typical value)
DCV	20 mV 0.06 % of rdg + 1 digit
	60 mV 0.03 % of rdg + 1 digit
	6 V 0.03 % of rdg + 1 digit
TC*2	R 300 to 1760 °C: 0.06 % of rdg + 1.1 °C 0 to 300 °C: ± 1.5 °C
	K 0 to 1370 °C: 0.06 % of rdg + 0.5 °C -200 to 0 °C: 0.1 % of rdg + 0.5 °C
	J 0 to 1100 °C: 0.05 % of rdg + 0.4 °C -200 to 0 °C: 0.15 % of rdg + 0.4 °C
	T 0 to 400 °C: 0.05 % of rdg + 0.4 °C -100 to 0 °C: 0.15 % of rdg + 0.4 °C -200 to -100 °C: 0.15 % of rdg + 0.6 °C
	N 0 to 1300 °C: 0.05 % of rdg + 0.5 °C -200 to 0 °C: 0.3 % of rdg + 0.5 °C
	RTD Pt100 0.04 % of rdg + 0.2 °C

*1: General operating conditions: 23±2 °C, 55±10% RH, supply voltage 90–132, 180–264 VAC, supply frequency within 50/60 Hz ±1%, warm-up of 30 minutes or more, no vibrations or other hindrances to performance.

*2: These values do not include the reference junction compensation accuracy.

rdg: reading value.



μR10000
(4-pen model)

■ STANDARD SPECIFICATIONS

General Specifications

Construction

Mounting:

Flush Panel Mounting (vertical), mounting next to each other (horizontal and vertical).

Mounting may be inclined up to 30°, rear below front (with horizontal base).

Allowable panel thickness: 2 to 26mm

Material:

Case: Steel, front door: aluminium die casting.

Case color:

Case and door-frame: Charcoal gray light (Mansell 10B 3.6 / 0.3 or equivalent)

Door: Splash and dust-proof (based on DIN 40050-IP54).

Dimensions:

144 × 144 × 220mm (see dimensional drawings)

Weight (approx.):

1 pen	2.1kg	4 pen	2.4kg
2 pen	2.2kg	6 dot	2.5kg
3 pen	2.3kg		

Model

1, 2, 3, and 4 pen, 6 dot-model.

Input

Inputs: DCV: Direct Current Voltage input
20mV to 50V, 1-5V range.

TC: Thermo couple.

RTD: Resistance Temperature Detector.

DI: Digital Input (contact or DC Voltage, TTL level).

DCA: Direct Current Input (using external shunt resistor (10Ω, 100Ω, 250Ω))

Measuring range: selectable per channel

Input Type	Range	Measuring Range
DC V	20 mV	-20.00 to 20.00mV
	60 mV	-60.00 to 60.00mV
	200 mV	-200.0 to 200.0mV
	2 V	-2.000 to 2.000V
	6 V	-6.000 to 6.000V
	20 V	-20.00 to 20.00V
	50V	-50.00 to 50.00V
	1-5V*1	1.000 to 5.000V

*1: Only linear scaling can be used (burnout is available)

Input	Range	Measuring Range °C	Measuring Range °F
TC	R*2	0.0 to 1760.0°C	32 to 3200°F
	S*2	0.0 to 1760.0°C	32 to 3200°F
	B*2	0.0 to 1820.0°C	32 to 3308°F
	K*2	-200.0 to 1370.0°C	-328 to 2498°F
	E*2	-200.0 to 800.0°C	-328.0 to 1472.0°F
	J*2	-200.0 to 1100.0°C	-328.0 to 2012.0°F
	T*2	-200.0 to 400.0°C	-328.0 to 752.0°F
	N*2	0.0 to 1300.0°C	32 to 2372°F
	W*3	0.0 to 2315.0°C	32 to 4199°F
	L*4	-200.0 to 900.0°C	-328.0 to 1652.0°F
U*4	-200.0 to 400.0°C	-328.9 to 752.0°F	
WRe*5	0.0 to 2400.0°C	32 to 4352°F	
RTD*6	Pt100*6	-200.0 to 600.0°C	-328.0 to 1112.0°F
	JPt100*6	-200.0 to 550.0°C	-328.0 to 1022.0°F
DI	DCV input	OFF: 2.4V less ON: 2.4V or greater	
	Contact input	Contact input ON/OFF	

*2: R, S, B, K, E, J, T, N: IEC 60584-1, DIN EN 60584-1, JIS C1602

*3: W: W-5% Re/W-26% Re(Hoskins Mfg. Co.), ASTM E988-96
(Type C equivalent of OMEGA Engineering Inc.)

*4: L: Fe-CuNi, DIN43710, U: Cu-CuNi, DIN43710

*5: WRe: W-3% Re/W-25% Re(Hoskins Mfg. Co.), ASTM E988-96
(Type D equivalent of OMEGA Engineering Inc.)

*6: Pt100: JIS C 1604, IEC 60751, DIN EN 60751
JPt100: JIS C1604, JIS C1606
Measuring current: i=1mA

Measurement Interval:

Pen model: 125ms / channel
Dot printing model: 1s / 6 dot (AD integration time is 20ms or 16.7ms)
2.5s / 6 dot (AD integration time is 100ms)

A/D Integration Time:

AUTO / FIX selectable
AUTO: 20ms (50Hz) or 16.7ms (60Hz), automatically selected depending on the power supply frequency.
FIX: 20ms (50Hz), 16.7ms (60Hz) or 100ms (50 / 60Hz)*1 can be selected.

*1 100ms integration time: only for dot printing model (not available for 1s / 6 dot measurement interval)

TC Burnout:

ON / OFF selectable (per channel).
Burnout upscale / downscale selectable (per channel)
Normal: less than 2kΩ, burnout: more than 10MΩ.
Measuring current: approx. 10μA.

1-5V Burnout:

Burnout: less than 0.2V

Filter:

Pen model:
Signal damping: ON / OFF selectable per channel
Time constant : 2, 5, 10sec
Dot printing model:
Moving average: ON / OFF selectable per channel
Moving average cycle: 2 to 16

Computation:

Differential computation:
Between any two channels, however reference channel number must be smaller than measuring channel number.
Available for DCV, TC, and RTD range.
Both channels must have same range.

Linear scaling:

Available for DCV, TC, RTD and DI range.
Scaling range: -20000 to 30000
Data display & printout range:-19999 to 30000
Decimal point: User selectable
Unit: User settable, up to 6 characters (alphanumerical & special characters).

Square root:

Available for DCV range.
Scaling range: -20000 to 30000
Data display & printout range:-19999 to 30000
Decimal point: User selectable
Unit: User settable, up to 6 characters (alphanumerical & special characters).
Low level cut off: 0.0 to 5.0% of recording span
Bias addition: -10.0 to 10.0% of recording span

Recording and Printing

Recording Method:

Pen model: Disposable felt pens, Plotter pen
Dot printing model: 6 color wire dot.

Pen Offset Compensation:

ON / OFF selectable (Pen model only)

Effective Recording Width: 100mm

Chart:

Plain-paper Z-fold chart (16m)

Step Response Time (pen):

Approx. 1s /IEC 61143 method

Recording Period:

Pen model:
Continuous for each channel.
Dot printing model:
Max. 6 channel / 10 sec (the shortest recording period)
7 to 12 channels* / 15 sec (the shortest recording period)
13 to 18 channels* / 20 sec (the shortest recording period)

* Including Math channels for the model with /M1 option

AUTO / FIX selectable

AUTO: Analog recording interval is depending on the chart speed
FIX: Analog recording interval is set to the shortest period

Chart Speed:

Pen model: 5 to 12000mm/h (82 increments)
Dot printing model: 1 to 1500mm/h (1mm step)

Chart Speed Change:

Speed 1, speed 2 change by remote control signals (option)

Chart Speed Accuracy:

Within ± 0.1% (for recordings longer than 1000mm, related to the grid of the chart paper)

Relation between Chart Speed and Printout:

(Pen-model)

Chart Speed	•Periodic Printout	•Alarm Printout •Message Printout •Chart Speed Change Time Printout
5 to 9mm/h	NA	Available
10 to 1500mm/h	Available	Available
1600 to 12000mm/h	NA	NA

(Dot-printing model)

Chart Speed	•Channel No. or Tag No.	•Periodic Printout	•Alarm Printout •Message Printout •Chart Speed Change Time Printout
1 to 9mm/h	Available	NA	Available
10 to 100mm/h	Available	Available	Available
101 to 1500mm/h	NA	NA	NA

Relation between chart speed and printing intervals of periodic printouts (For AUTO interval setting):

(Pen-model)

Chart Speed	Printing Interval of Periodic Printout
5 to 9mm/h	NA
10 to 18mm/h	Every 8 hours
20 to 36mm/h	Every 4 hours
40 to 72mm/h	Every 2 hours
75 to 135mm/h	Every hour
150 to 180mm/h	Every 30 minutes
200 to 320mm/h	Every 20 minutes
360 to 1500mm/h	Every 10 minutes
more than 1600mm/h	NA

(Dot-printing model)

Chart Speed	Printing Interval of Periodic Printout
1 to 9mm/h	NA
10 to 19mm/h	Every 8 hours
20 to 39mm/h	Every 4 hours
40 to 79mm/h	Every 2 hours
80 to 100mm/h	Every hour
101 to 1500mm/h	NA

Recording Colors:

Pen model:

pen1=red, pen2=green, pen3=blue, pen4=violet, plotter pen=purple

Dot printing model:

ch1=purple, ch2=red, ch3=green, ch4=blue, ch5=brown, ch6=black (color can be assigned to any channel)

Recording Format:

1. Analog recording:

Analog recording ON/OFF selectable for each channel of dot model

Zone recording:

Span: More than 5mm (1mm step)

Partial expanded recording:

Boundary position: 1 to 99%

Boundary value: Within recording span

2. Digital printout:

Channel (dot model only):

Channel number or TAG will be printed during analog recording. Approx. every 25mm this print will occur.

ON / OFF selectable (common for all channels)

Alarm:

At the right side of the chart, CH. No. or TAG, Type of alarm, date/time*2 of alarm ON / OFF will be printed. Time of alarm ON / OFF, time of alarm ON, OFF selectable (common for all channels).

Periodic printout contents:

Date (mm/dd/yy), time(hh:mm), measurement data of each channel, scale printout, recording color, chart speed

- Measurement data of each channel:

- a. ON/OFF selectable
- b. Channel No. or tag, alarm status (for instantaneous mode), measuring value (according to instantaneous mode or report mode), measuring unit (up to 6 characters)

- Scale printout:

- a. ON/OFF selectable (common for all channels)
- b. 0 and 100% scale value (when using partial expanded recording, boundary value is recorded)
- c. Printout available in case of more than 40 mm of recording span

- Recording color:

Only for pen model (OFF selectable)

- Periodic print interval:

- a. Using internal timer
- b. Standard time 00:00 to 23:00(on the hour)
- c. Print interval setting (AUTO/MAN)*4
 AUTO: Automatically set as chart speed
 MAN: 10, 12, 15, 20, 30 minute, 1, 2, 3, 4, 6, 8, 12, 24 hour

- Periodic printout mode:

Selectable from Instantaneous value mode / report mode/OFF mode

- a. Instantaneous value mode: Measuring value for each channel
- b. Report mode: Selectable from MIN, MAX, AVE, MIX(MIN/MAX/AVE), SUM, INST
 Report interval: Same as periodic printout interval
- c. OFF mode: Periodic printout is not executed.

- Message printout:
With panel key or remote control option, up to 5 messages can be printed.
Contents: Date/time*1 and message (up to 16 characters).
- Record start time:
Date/time*2 will be printed when recording starts, ON / OFF selectable.
- Chart speed printout:
Date/time*2 when chart speed is changed will be printed, ON / OFF selectable.
- List printout*3:
Listings of range and alarm setting, etc. will be printed.
- Manual printout*3:
With panel key or remote control option, measuring value will be printed.
- SET UP printout*3:
Listings of settings in SET UP Mode will be printed.
- *1 Selectable from hh:mm, hh:mm:ss, mm/dd hh:mm, mm/dd hh:mm:ss, mm/dd/yy hh:mm:ss, OFF.
- *2 Selectable from hh:mm, hh:mm:ss, mm/dd hh:mm, mm/dd hh:mm:ss, mm/dd/yy hh:mm:ss
- *3 During printout trend recording will be interrupted.
- *4 According to printout settings all the items are not printed.

Display

- Display Method:
VFD 101 × 16 dot matrix
- 15 display screens can be selected from the any of followings (default display is 6 screens)
 - 1 channel digital display*1, *4: AUTO*2/MAN*3
 - 2 channel digital display*1, *4: AUTO*2/MAN*3
 - 4 channel digital display*4: Channel No., alarm type, measuring value are displayed
 - 6 channel digital display*4: Measuring value display (only for dot model)
 - 1 channel digital display*4 + 1 channel bar graph display: AUTO*2/MAN*3
 - 1 channel digital display*4 + 4 channel bar graph display (only for pen model): AUTO*2/MAN*3
 - 2 channel digital*4 + 2 channel bar graph display: AUTO*2/MAN*3
 - 4 channel bar graph display (only for 4 pen model)
 - 6 channel bar graph display (only for dot model)
 - Flag display
 - DI/DO display (Available for model with /R1 or /A1, /A2, /A3 option)
 - Alarm status*1
 - Date/time display (mm/dd/yy hh:mm)+Chart speed display
 - Date/time display (mm/dd/yy hh:mm)*5
 - Chart speed display*5
 - Status display*1
 - System display
 - Display Off (light out)*1
 - Split display: Upper/lower position display
 - Tag 1 channel digital display*1, *4: AUTO*2/MAN*3
 - Tag 2 channel digital display*4: AUTO*2/MAN*3
 - Tag 1 channel digital display*4 + 1 channel bar graph display: AUTO*2/MAN*3
 - Tag 1 channel digital display + 4 channel bar graph display*4 (4 pen model only)
 - Batch name For the model with /BT1 option
 - SD card status display....When the /EM1 option is installed

- Status display:
Recording in progress (RECORD)
Shared alarm display (ALARM)
Alarm occurrence No. display (1 2 3 4 5 6)
Chart end indicator (CHARTEND).....For the model with /F1 option
Computation in progress(MATH).....For the model with /M1 option
Key lock display (KEYLOCK)
- *1 The displays can be specified for split display.
- *2 AUTO: Channel No., alarm type, measuring value, and measuring unit (6 digit) are displayed in order of channel No.
For 1 channel digital display + 1 channel bar graph display, the unit display is 3 digit.
- *3 MAN: The same contents of AUTO for the specified channel are displayed.
- *4 Display updated interval can be selected from AUTO / MAN.
AUTO: 1s / 2s / 3s / 4s / 5s
MAN: 2s (pen model), same as measurement interval (dot model)
- *5 The display can be specified only for split display.

Power Supply

- Rated Power Voltage:
100 to 240VAC, automatically selected depending on the power supply voltage
- Usable power voltage ranges:
90 to 264VAC
- Rated Power Frequency:
50 / 60 Hz, automatically selected
- Power Consumption:

(approx.)

	100VAC Power Source	240VAC Power Source	Maximum
1-4 pen	12VA*	17VA*	40VA
6 dot	13VA*	18VA*	40VA

* : In Balance

Alarm

- Number of alarm levels:
Up to four levels for each channel
- Alarm types:
High and low, limits, differential high and low limits, high and low rate-of-change limits and delay high and low
- Alarm delay time: 1 to 3600s
- Interval time of rate-of-change alarms:
The measurement interval times 1 to 15
- Display:
Alarm value is indicated as a point on the bar graph.
- In occurring an alarm:
 - On bar graph display, a point indicator is flashing.
 - On digital display, an alarm type indicator is shown.
 - A channel number of occurring alarm is displayed.
 - Shared alarm display
- Hysteresis:
0.0 to 1.0% (0.1% step) of recording span (only High, Low alarm, common for all channels and all levels).

Alarm indication when ALARM ACK-key is pressed:

Non-hold-type:

Alarm display is not affected when the ALARM ACK-key is pressed.

Hold-type:

When alarm occurs, alarm indicator will start flashing. After ALARM ACK-key is pressed, indicator will show status of the alarm.

Hold-type:

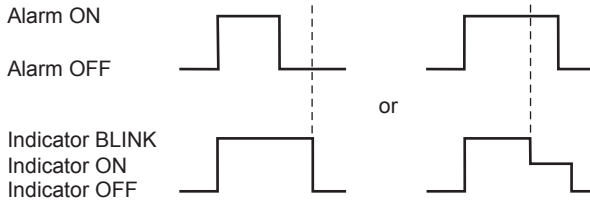

Non-hold type:

No action will occur when ACK-key is pressed.

ALM indicator depends on alarm status.

F01.ai

Other Specifications

Clock:

With calendar function

Summer and winter time:

Summer and winter time can be set.

Clock Accuracy:

100 ppm, however not including error due to turning ON / OFF power

Panel Key Lock:

Protection by password

(Any of RCD, MENU, FEED key and functions (Alarm ACK, Math, Printout, Message, Buffer clear, Digital PRT, Pen exchange (only for pen model), ribbon cassette replacement (only for dot model), data save, replaying on chart paper (only for dot model), removing the SD memory card) can be locked).

Internal illumination:

White LED

Memory backup:

Lithium battery to protect setting parameters. Life is approx. ten years (at room temperature, and for standard model) and is installed inside the recorder.

Insulation Resistance:

Each terminal to ground terminal: More than 20M Ω (measured at 500VDC).

Dielectric Strength:

Power supply to ground terminal:
1500V AC (50 / 60Hz), 1 min

Contact output terminal to ground:
1500V AC (50 / 60Hz), 1 min

Measuring input terminal to ground:
1000V AC (50 / 60Hz), 1 min

Between measuring input terminals:
1000V AC (50 / 60Hz), 1 min
(except for RTD, since b-terminal is common).

Between remote control terminal to ground:
500V DC, 1min.

Mechanical noise:

Machine Noise Information Ordinance 3. GSGV, Jan. 18, 1991:

The maximum sound pressure level is equal or less than 60dB (A) according to ISO7779.

Safety and EMC standards

CSA

CSA22.2 No.61010-1, CSA C22.2 No.61010-2-030 (NRTL/C*) installation category II, measurement category II, pollution degree 2
* For marking that includes NRTL, a mark with "US" (USA) printed on the right side of the CSA mark, and "C" (Canada) printed on the left side appears on this instrument.

CE

EMC directive:

EN61326-1 compliance, Class A, Table 2
(For use in industrial locations)

EN61000-3-2 compliant

EN61000-3-3 compliant

EN55011 compliant, Class A Group 1

Low voltage directive:

EN61010-1, EN61010-2-030 compliant, installation category II measurement category II, pollution degree 2

EMC Regulatory Arrangement in Australia and New Zealand: EN55011 compliance, Class A, Group 1

KC marking:

Electromagnetic wave interference prevention standard, electromagnetic wave protection standard compliance

WEEE Directive: Compliant

Normal Operating Conditions

Power voltage: 90 to 132, 180 to 264VAC

Power frequency: 50Hz \pm 2%, 60Hz \pm 2%

Ambient temperature: 0 to 50 $^{\circ}$ C

Ambient humidity: 20 to 80% RH (at 5 to 40 $^{\circ}$ C)

Vibration: 10 to 60Hz, 0.2m/s² or less

Shock: Not acceptable

Magnetic field: Less than 400A/m (DC and 50, 60Hz)

Noise:

Normal Mode (50 / 60Hz):

DCV Peak value including signal must be less than 1.2 times the measuring range.

TC Peak value including signal must be less than 1.2 times the measuring thermal electromotive force.

RTD less than 50mV.

Common Mode (50 / 60Hz):

Less than 250VAC rms. for the whole range

Maximum noise voltage between channels

(50 / 60Hz) :

Less than 250VAC rms

*In case /N2 (3 leg RTD) is specified

less than 200VAC rms for 6 dot model

Operating Position:

Frontward: 0 $^{\circ}$ Backward: Within 30 $^{\circ}$ from horizontal

Warm-up Time:

Min. 30 minutes after power has been turned ON.

Altitude: 2000m or less

Standard Performance

Measuring and Recording Accuracy:

(Following specifications apply to operation of the recorder under standard operation conditions: temperature 23 ± 2°C, humidity 55 ± 10%RH, power supply voltage 90 to 132V, 180 to 264V AC, power supply frequency 50/60Hz ± 1%, warm-up time at least 30 minutes, other ambient conditions like vibration should not adversely affect the recording operation).

Input	Range	Measuring (digital display)		Recording (analog)	
		Measurement Accuracy*	Max. Resolution	Recording Accuracy	Resolution
DC V	20mV	±(0.1% of rdg+2 digits)	10µV	±Measurement accuracy ±0.3% of recording span	Pen model dead band: 0.2% of recording span
	60mV		10µV		
	200mV		100µV		
	2V		1mV		
	6V		1mV		
	20V		10mV		
	50V	±(0.1% of rdg+3 digits)	10mV		Dot printing model resolution: 0.1mm
	1-5V	±(0.1% of rdg+2 digits)	1mV		
TC (excluding the accuracy of reference junction compensation)	R S B	±(0.15% of rdg+1°C) but R, S : 0 to 100°C, ±3.7°C 100 to 300°C, ±1.5°C B : 400 to 600°C, ±2°C, and is not guaranteed below 400°C	0.1°C	±Measurement accuracy ±0.3% of recording span	Pen model dead band: 0.2% of recording span Dot printing model resolution: 0.1mm
	K	±(0.15% of rdg+0.7°C) but -200 to -100°C ±(0.15% of rdg+1°C)			
	E J T	±(0.15% of rdg+0.5°C) but J : -200 to -100°C ±(0.15% of rdg+0.7°C)			
	N	±(0.15% of rdg+0.7°C)			
	W	±(0.15% of rdg+1°C)			
	L U	±(0.15% of rdg+0.5°C) but L : -200 to -100°C ±(0.15% of rdg+0.7°C)			
	WRe	±(0.2% of rdg+1.0°C)			
	RTD	Pt100 JPt100			

NOTE: Recording span is 100 mm.

*including the measurement accuracy at linear scaling.

Accuracy in case of scaling:

Accuracy during scaling (digits) =

measuring accuracy (digits) × multiplier
+ 2 digits
(rounded up)

Where the multiplier = scaling span digits /
recording span digits

Example:

DCV 6V range
recording span : 1.000 to 5.000V
scaling span : 0.000 to 2.000
measuring accuracy = ± (0.3% × 5V + 2 digits)
± (0.015V (15 digits) + 2)
± (17 digits)
multiplier = 2000 digits (0.000 to 2.000 / 4000 digits
(1.000 to 5.000V) = 0.5
Accuracy during scaling = 17 digits × 0.5 + 2
= 11 digits
(rounded up)

Maximum Allowable Input Voltage:

± 10VDC (cont.) for less than 200mVDC ranges
and TC, RTD, DI ranges
± 60VDC (cont.) for more than 2VDC

Reference Junction Compensation:

INT / EXT selectable (per channel)

Reference Junction Compensation Accuracy (above 0 °C):

Type R, S, B, W, WRe: ± 1 °C
Type K, J, E, T, N, L, U: ± 0.5 °C

Input Resistance:

More than 10MΩ (TC, 20mV, 60mV, 200mV
range)
Approx. 1MΩ (More than 2V range).

Input Source Resistance:

DCV, TC: 2kΩ or less
RTD: 10Ω or less / wire (The resistance of all
three wires must be equal)

Input Bias Current:

Less than 10nA (except when burnout is
specified).

Maximum Common Mode Voltage:

250VAC rms (50 / 60Hz)

- Maximum Differential Noise between Channels:
250VAC rms (50 / 60Hz)
200VAC rms (50 / 60Hz, for the mode / with / N2 option)
- Interference between Channels:
120dB (Input external resistance 500Ω, the deviation in the case that 60V is applied to another channel)
- Common Mode Rejection Ratio:
120dB (50/60Hz ± 0.1%, 500Ω imbalance between '-' terminal and ground)
- Normal Mode Rejection Ratio:
40dB (50 / 60Hz ± 0.1%)

Effect of Operating Conditions

- Effect of Ambient Temperature:
Effect of ambient temperature variation of 10°C.
Digital display: Within ± (0.1% of rdg+1 digit)
Recording: Within Digital display ± 0.2% of recording span (excluding RJC error)
- Effect of Power Supply:
Effect of variation within 90 to 264VAC in rated power supply voltage:
(50 or 60Hz)
Digital display: Within ± 1 digit
Recording: Within ± 0.1% of recording span
Effect of rated power frequency variation of ± 2Hz (at 100VAC):
Digital display: Within ± (0.1% of rdg+1 digit)
Recording: Same as digital display
- Effect of Magnetic Field:
Effect of AC (50 / 60Hz) or DC 400AT/m field:
Digital display: Within ± (0.1% of rdg+10 digits)
Recording: Less than ± 0.5% of recording span
- Effect of Input Source Resistance:
Effect of Input Source Resistance variation of +1kΩ :
DCV range:
Ranges less than 200mV: Within ± 10 μV
Ranges more than 2V: Within -0.1% of rdg
TC range:
Within ± 10 μV
RTD range:
- Effect of 10Ω per wire (resistances of three wires must be equal):
Digital display: Within ± (0.1% of rdg+1 digit)
Recording: Within Digital display ± 0.1% of recording span
- Effect of difference of three wires:
Digital display: 0.1°C per 40 mΩ (approx.) over Pt100 range.
- Effect of Operating Position:
Digital display: Within ± (0.1% of rdg+1 digit) (within 30° backwards)
Recording: Within Digital display ± 0.1% of recording span (within 30° backwards)
- Vibration:
Effect when sine-wave motion of frequency 10 to 60Hz and acceleration of 0.2m/s² is applied to the instrument in the direction of three axes for two hours:
Digital display: Within ± (0.1% of rdg+1 digit)
Recording: Within Digital display ± 0.1% of recording span

Transport and Storage Conditions

- No malfunction will occur under these conditions, however when returning to normal operation conditions, calibration might be necessary.
- Temperature: -25°C to 60°C
- Humidity: 5 to 95% RH (no condensation)
- Vibration: 10 to 60Hz, 4.9m/s²
- Shock: Less than 392m/s² (while being packed)

Contents of μR10000 firmware version change (R1.11)*

1. Date display type for printout/display: Selectable from below table

Format	Printout/display example	Remark
yy/mm/dd	2005/08/31	Additional format
mm/dd/yy	08/31/2005	
dd/mm/yy	31/08/2005	
dd.mm.yy	31.08.2005	
mm.dd.yy	Aug.31.2005	Default (same as before)

2. Available for replacing ribbon cassette with power ON for dot models.
- Ribbon cassette replacement function is added within FUNC key operation.
- Available for keylock on to ribbon cassette replacement function.
3. /C3: RS-422A/485communication interface Protocol: Modbus/RTU SLAVE (2-wire)
4. DST Setting method
Month, day of week, and week number are set.

*: The settings of above alteration can not be done with configuration software (RXA10: R1.02 or before).

■ OPTIONAL SPECIFICATIONS

- /A1: Alarm Output Relay (2 contacts)**
- /A2: Alarm Output Relay (4 contacts)**
- /A3: Alarm Output Relay (6 contacts)**
When alarm occurs, output relay on rear terminal will be activated.
- AND / OR selectable.
- Energized/ deenergized selectable (common for all relays).
- Hold type/ non-hold type selectable (common for all relays).
- Reflash relay:
Alarms can be assigned to an output relay (I01-I03)
- Relay contact rating: DC 250V / 0.1A
AC 250V / 3A
- Type of relay output: NO-C-NC

Note : Alarm ACK key:
Non-Hold type:
No effect when ALARM ACK-key is pressed (no effect on output relay).
Hold type:
When ALARM ACK-key is pressed, the output relay will be reset.

Non-hold-type:

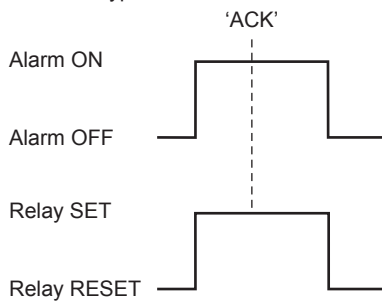

Hold-type:

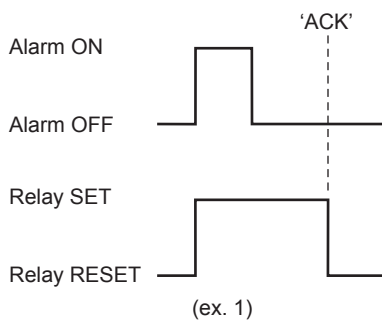

F02.ai

Hold-type:

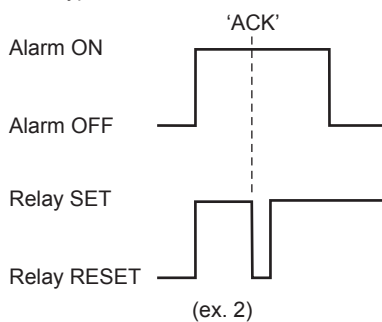

F03.ai

/C3: RS-422A / 485 Communication Interface

By using this communication function, setting and control of data can be done by a host-computer. Data can also be output to the host-computer.

- Synchronization method: start-stop asynchronous transmission
 - Specifications: Conform to EIA RS-422A / 485 standard
 - Communication method: 4-wire half-duplex multi-drop connection (1: N (N=1 to 32))
 - Transfer rate: 1200, 2400, 4800, 9600, 19200, 38400bps
 - Data length: 7 or 8 bit
 - Stop bit: 1 bit
 - Parity: Odd, even or none
 - Communication distance: Up to 1.2km
 - Communication mode: ASCII (control / setting / measured data) or Binary (measured data)
- Modbus: RTU SLAVE

/C7: Ethernet Interface

Electrical and mechanical specifications:
 Conforms to IEEE 802.3
 Transmission media: 10 Base-T
 Protocol: TCP, IP, UDP, ICMP, ARP

/F1: FAIL / Chart End Detection and Output

If an error in the CPU board occurs, or when the chart reaches its end, output relay on the rear terminal will be activated. Besides, when the chart reaches its end, 'CHARTEND' indicator will be shown on the display.
 Relay contact rating:
 DC 250V / 0.1A, AC 250V / 3A

/H2: Clamped Input Terminal

Using clamped input terminals as input terminal.

/H3: Non-glare Door Glass

Provides non-reflective glass in the front door.

/H5]: Portable Type

Provides carrying handle and power code. (cable length: approx. 2m, 3 pin plug)

/M1: Mathematical Functions

- Computation channel recording
 - Pen model: Measurement and computation channel can be assigned to 1-4pen.
 - Dot model: ON/OFF selectable for each channel
 - Zone recording
 - Partial expanded recording
 - Alarm for computation channel
 - Number of levels: Up to four levels for every channel (High and low limits, delay High and low)
 - Number of computation channel: 8 (pen model) 12 (dot model)
 - Computation expression: Up to 120 characters can be used
 - Types:
 - Four arithmetic operations, square root, absolute, common logarithm, exponential, power, relational operations (>, ≥, <, ≤, =, ≠), logic operations (AND, OR, NOT, XOR)
 - Constant*1: Up to 30 constants can be used
 - Communication digital input*1:
 - Pen model: 8 channels
 - Dot model: 12 channels
 - Remote input*1: Up to 5 remote inputs status(I/O) can be used in computation expression
- *1 It cannot be used in statistical computation expression.

Statistical computation

- The following computation can be executed for the specified internal timer
- Types of statistics: MAX, MIN, AVE, SUM, MAX-MIN (Totalization)
- Type of internal timer: 3 types
 - Timer types: Internal of periodic printout, absolute time, relative time

/N1: Cu10, Cu25 RTD input

This option allows Cu10 and Cu25 RTD inputs to be added to the standard input types.

Cu10, Cu25 Measurement Range

	Input Type	Measurement Range
RTD	Cu10(GE)	-200 to 300°C (-328 to 572°F)
	Cu10(L&N)	
	Cu10(WEED)	
	Cu10(BAILEY)	
	Cu10 : α= 0.00392 at 20°C	
	Cu10 : α= 0.00393 at 20°C	
	Cu25* : α= 0.00425 at 0°C	

*Measuring current i=1mA

Measurement / Recording Accuracy

Input Type	Measurement Accuracy	Recording Accuracy
Cu10(GE) Cu10(L&N) Cu10(WEED) Cu10(BAILEY) Cu10 : α= 0.00392 at 20°C Cu10 : α= 0.00393 at 20°C	±(0.4% of rdg + 1.0°C)	±Measurement accuracy ±0.3% of recording span
Cu25 : α= 0.00425 at 0°C	±(0.3% of rdg + 0.8°C)	

/N2: 3 Leg Isolated RTD Input

A, B, b legs are isolated input type

/N3: Expansion Inputs

This option allows 14 types inputs such as Pt50, PR40-20, PLATINEL inputs to be supported besides the standard input types.

/N3 Measurement Range

Input	Measuring Range	
TC (Excluding RJC accuracy)	PR40-20	0.0 to 1900.0°C / 32 to 3452°F
	PLATINEL	0.0 to 1400.0°C / 32 to 2552°F
	NiNiMo	0.0 to 1310.0°C / 32 to 2390°F
	W/WRe26	0.0 to 2400.0°C / 32 to 4352°F
	Type N (AWG14)	0.0 to 1300.0°C / 32 to 2372°F
	Kp vs Au7Fe	0.0 to 300.0K / —
RTD (Measuring contact i=1mA)	Pt25	-200.0 to 550.0°C / -328.0 to 1022.0°F
	Pt50	-200.0 to 600.0°C / -328.0 to 1112.0°F
	Ni100(SAMA)	-200.0 to 250.0°C / -328.0 to 482.0°F
	Ni100(DIN)	-60.0 to 180.0°C / -76.0 to 356.0°F
	Ni120	-70.0 to 200.0°C / -94.0 to 392.0°F
	J263*B	0.0 to 300.0K / —
	Cu53	-50.0 to 150.0°C / -58.0 to 302.0°F
	Cu100*1	-50.0 to 150.0°C / -58.0 to 302.0°F

*1: Cu100: a = 0.00425 at 0°C

Following specifications apply to operation of the recorder under standard operation conditions:
 temperature 23± 2°C, humidity 55 ± 10%RH,
 power supply voltage 90 to 132V, 180 to 264V AC,
 power supply frequency 50/60Hz ± 1%,
 warm-up time at least 30 minutes, other ambient conditions like vibration should not adversely affect the recording operation

Reference junction compensation accuracy

When the input terminal temperature is balanced (at least 60 minutes after power-on)
 PLATINEL, NiNiMo, W/WRe26, Type N (AWG14): ±1.0°C
 PR40-20, KpvsAu7Fe: Without reference junction compensation (fixed at 0°C)

Measurement / Recording Accuracy

Input	Measuring Accuracy	Recording Accuracy
PR40-20*1	0 to 450°C 450 to 750°C 750 to 1100°C 1100 to 1900°C	Not guaranteed ±(0.9% of rdg+3.2°C) ±(0.9% of rdg+1.3°C) ±(0.9% of rdg+0.4°C)
PLATINEL		±(0.25% of rdg+2.3°C)
NiNiMo		±(0.25% of rdg+0.7°C)
W/WRe26	0 to 400°C 400 to 2400°C	within ±15.0°C ±(0.2% of rdg+2.0°C)
Type N(AWG14)		±(0.2% of rdg+1.3°C)
Kp vs Au7Fe	0 to 20K 20 to 300K	±4.5K ±2.5K
Pt25		±(0.15% of rdg+0.6°C)
Pt50		±(0.3% of rdg+0.6°C)
Ni100(SAMA) Ni100(DIN) Ni120		±(0.15% of rdg+0.4°C)
J263*B	0 to 40K 40 to 300K	±3.0K ±1.0K
Cu53		±(0.15% of rdg+0.8°C)
Cu100		±(0.2% of rdg+1.0°C)

*1: PR40-20 : No reference junction compensation (0°C fix)

/P1 : 24VDC/AC Power Supply

Rated power supply: 24VDC/AC

Allowable power supply voltage range:

21.6 to 26.4 VDC/AC

Dielectric strength:

Power supply to ground terminal: 1000VAC

Power Consumption:

(approx.)

Supply Voltage	1-4 pen	6 dot	Max.
24VDC	7VA*	8VA*	25VA
24VAC (50/60Hz)	13VA*	13VA*	35VA

* In Balance

/R1: Remote Control

5 are selectable from the below mentioned remote controls.

	Number of settings	Signal
Recording start / stop	1	edge
Chart speed change	1	level
Message printout start*1	5	trigger
Manual printout start	1	trigger
Alarm ACK	1	trigger
Time adjustment	1	trigger
(Adjusting the time to a preset time)		
Computation start / stop*2	1	edge
Computation reset*2	1	trigger
Batch comment switch*3	1	level
Priority remote recording*3	1	level
Data save On/Off	1	level

*1 Up to 5 messages can be set

*2 /M1 option is necessary

*3 Available for the model with /BT1 option

/CC1: Calibration correction

Corrects the measurement value of each channel using segment linearizer approximation.

Number of segment points: 2 to 16

Setting method: Bias, Absolute value

Target Channel: Measurement channel

Target range:

Input range (DCV, TC, RTD)

Linear scaling range (DCV, TC, RTD, 1-5V)

But, DI, Differential computation and square root are not included.

/BT1: Header printout

Batch name, comment, time, chart speed are printed in record Start/Stop.

Message printout including measured value/computation value is available.

The pen offset compensating data can be ejected after recording stops.

- Printout contents:

Batch name: Batch number-Lot number
(ON/OFF selectable)

Batch number: Up to 26 characters can be set

Lot number: 4 digits/6 digits/OFF selectable

Start/Stop comment:

Up to 32 characters × 5 lines can be set

Start/Stop time: ON/OFF selectable

Start/Stop chart speed: ON/OFF selectable

- Message printout:

Printout contents

(message format: ON/OFF selectable)

ON: any (date/time, message (up to 16 characters), measured value) can be selected (up to 35 characters)

OFF: Date/time + message (up to 16 characters)

/EM1: SD Memory Card

SD memory cards can be used as external storage media.

Measured data can be saved (The μ R10000 does not support FIFO function (overwrite function)) and replayed (only for dot model), and setting parameters can be saved and loaded.

Media: SD card (SD/SDHC) (up to 32 GB)

Format: FAT32 or FAT16

■ APPLICATION SOFTWARE

With Ethernet (/C7), RS-422A/485 (/C3), or Interface unit, μ R10000 setting can be configured.

• RXA10 Configuration Software

System requirements

OS: Windows Vista Home Premium SP2 (excluding the 64-bit edition) / Windows Vista Business SP2 (excluding the 64-bit edition) / Windows 7 Home Premium, SP1 (32-bit and 64-bit editions) / Windows 7 Professional, SP1 (32-bit and 64-bit editions), Windows 8.1 Update (32-bit and 64-bit editions, desktop mode), Windows 8.1 Pro Update (32-bit and 64-bit editions, desktop mode)

Processor:

CPU: OS compatible

Memory: Enough space to load the application

Hard disk: Enough space to store the installation files

CD-ROM drive: A CD-ROM drive supported by the OS.

Mouse: A mouse supported by the OS.

Monitor:

OS compatible display

1024 x 768 dots or higher, 65536 colors or more recommended

Main functions (as a package):

Configuration software:

Configuration via communication:

Configures the station, excluding the communication setting, or sets it in set mode.

• Interface unit (attached with RXA10 configuration software)

Method of power supply: Power supply from μ R10000

Connector type: D-Sub 9-pin plug (male)

Electrical and mechanical specifications:

Conforms to EIA-574 (9-pin EIA-232 (RS232))

RS422A/485 communication interface (/C3) and interface unit cannot work together.

• Universal Viewer (free download)

Data files saved on the SD memory card can be loaded and displayed. For specified data, you can also perform statistical computation over an area and export to ASCII, Excel, or other formats.

<http://www.yokogawa.com/ns/>

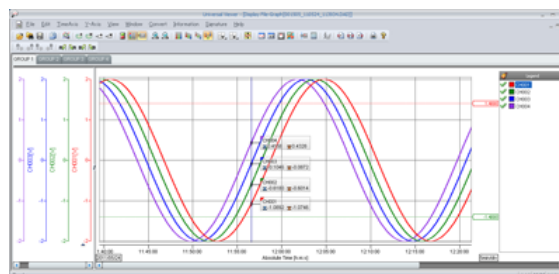
Displaying waveforms with the Viewer

Model Codes

Model Code	Suffix Code	Option Code	Description
436101			μR10000 1 pen recorder
436102			μR10000 2 pen recorder
436103			μR10000 3 pen recorder
436104			μR10000 4 pen recorder
436106			μR10000 6 dot recorder
Language	-2		English/German*10/French*10, degF & DST
Option	/A1		Alarm output relay (2 contacts)*1
	/A2		Alarm output relay (4 contacts)*1
	/A3		Alarm output relay (6 contacts)*1, *2
	/BT1		Header printout
	/C3		RS-422A/485 communication interface *3, *4
	/C7		Ethernet communication interface *3
	/CC1		Calibration Correction
	/EM1		SD memory card *4
	/F1		FAIL/chart end detection and output*2
	/H2		Clamped input terminal *5
	/H3		Non-glare door glass
	/H5[]*9		Portable Type *8
	/M1		Computation function
	/N1		Cu10, Cu25 inputs
	/N2		3 legs Isolated RTD *5, *6
/N3		Expansion inputs *7	
/P1		24VDC/AC power supply *8	
/R1		Remote control 5 contacts	

Model Code	Description	OS
RXA10-01	RXA10 Configuration software*	Windows Vista/7/8.1
RXA10-02	RXA10 Configuration software* (With interface unit)	Windows Vista/7/8.1

*This software applies for Windows Vista from R3.03 version. This software applies for Windows7 from R3.04.01 version. This software applies for Windows 8.1 from R3.05.01 version.

Notes on using the RXA10 Configuration Software
When the /EM1 recorder option is specified, the interface unit supplied with the RXA10 Configuration Software cannot be used. Either specify the /C7 recorder option (Ethernet interface) and communicate via Ethernet, or save the μR settings to an SD memory card and load them from the PC.

- *1: Only one of /A1, /A2, /A3 can be selected
- *2: /A3 and /F1 can not be specified together
- *3: /C3 and /C7 can not be specified together
- *4: /C3 and /EM1 can not be specified together.
- *5: /H2 and /N2 can not be specified together
- *6: /N2 can be specified only for dot model
- *7: 14 types inputs: Pt50 RTD, PR40-20, PLATINEL TC etc.
- *8: /H5[] and /P1 can not be specified together
- *9: /H5[] (D-power cord UL, CSA, st'd, F-Power cord VDE st'd, R-Power cord SAA st'd, J-Power cord BS st'd, H-Power cord GB st'd)
- *10: Available from firmware version R1.21

For the RoHS (2011/65/EU) directive, please refer to the General Specifications "List of RoHS (2011/65/EU) Directive Compliant Products (GS 04A01A01-00EN)".

STANDARD ACCESSORIES

Name		1 pen	2 pen	3 pen	4 pen	6 dot
Z-fold chart		1	1	1	1	1
6 color ribbon cassette		-	-	-	-	1
Disposable felt-pen cartridge	Red	1	1	1	1	-
	Green	-	1	1	1	-
	Blue	-	-	1	1	-
	Violet	-	-	-	1	-
Plotter pen	Purple	1	1	1	1	-
SD memory card (1GB) (In case /EM1 is specified)		1	1	1	1	1
Mounting brackets		2	2	2	2	2
Operation Manual		1	1	1	1	1

The electronic manual (CD, part no. B8800LZ) is available for purchase. Please contact your nearest YOKOGAWA dealer for details.

SPARES/OPTIONAL ACCESSORIES

Name		Model Code (Parts No.)	Specification
Z-fold chart		B9565AW	10 (sales unit)
6 color ribbon cassette		B9901AX	1 (sales unit)
Disposable felt-pen cartridge	Red	B9902AM	1 (sales unit, 3 pieces/unit)
	Green	B9902AN	1 (sales unit, 3 pieces/unit)
	Blue	B9902AP	1 (sales unit, 3 pieces/unit)
	Violet	B9902AQ	1 (sales unit, 3 pieces/unit)
Plotter pen	Purple	B9902AR	1 (sales unit, 3 pieces/unit)
SD memory card (1GB)		773001	1 (sales unit)
Mounting brackets		B9900BX	2 (sales unit)
Shunt resistor	(for screw input terminal)	4159 20	250Ω ±0.1%
		4159 21	100Ω ±0.1%
		4159 22	10Ω ±0.1%
	(for clamped input terminal)	4389 20	250Ω ±0.1%
		4389 21	100Ω ±0.1%
		4389 22	10Ω ±0.1%

- Microsoft, MS and Windows are registered trademarks of Microsoft Corporation USA.
- Pentium are registered trademarks of Intel Corporation.
- Modbus is a registered trademark of AEG Schneider
- Other company and/or product names are registered trade mark of their manufactures.

REAR TERMINAL ARRANGEMENTS

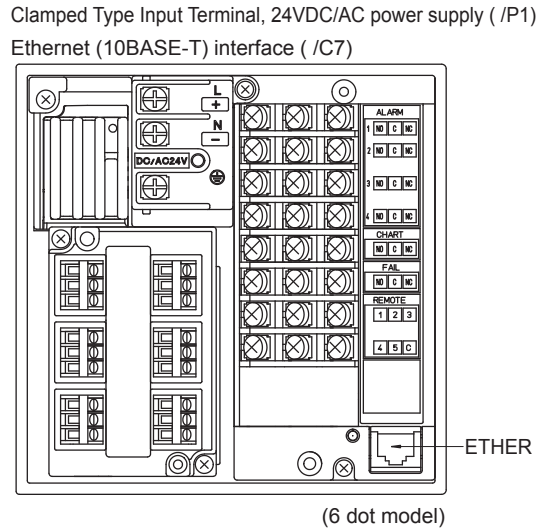
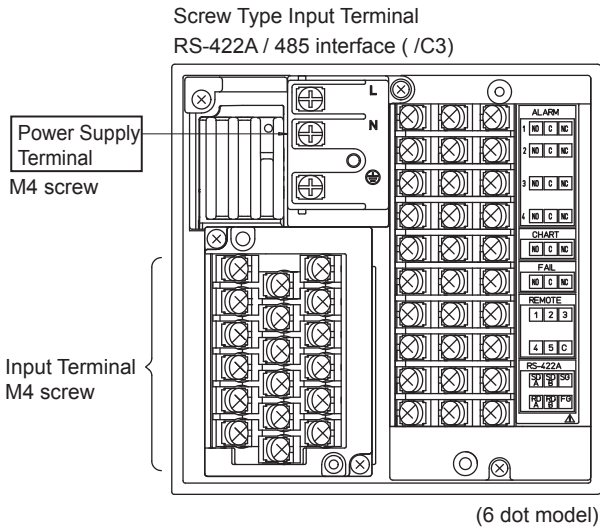

If /C7 is specified and /A□ and /R1 are not specified, the function of the accessory screw terminal block is not available.

Input Terminals

4 Pen Screw Type

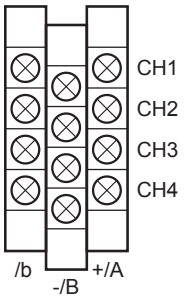

6 Dot Screw Type

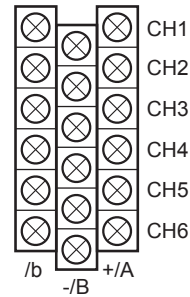

4 Pen Clamped Type (/H2)

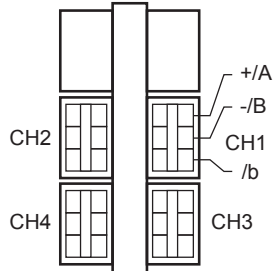

6 Dot Clamped Type (/H2)

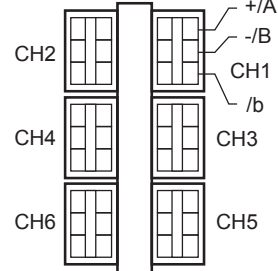

Option Terminals

/A1/F1/R1 Combination

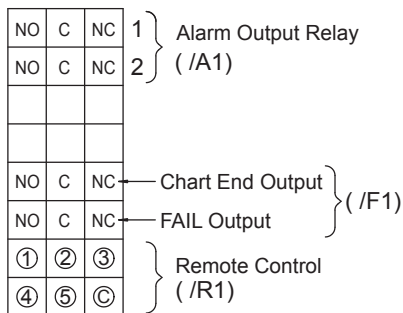

/A2/F1/R1 Combination

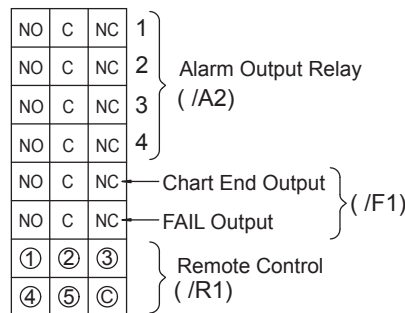

/A3/R1 Combination

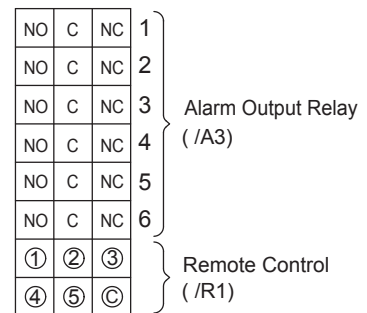

F04.ai

NOTE: Compatibility with Input Terminals and Option Terminals of Older Models

The input and option terminals of this instrument are specific to this instrument. Do not connect to the input terminals or option terminals of the μR1000, or other models as malfunction can result.

DIMENSION

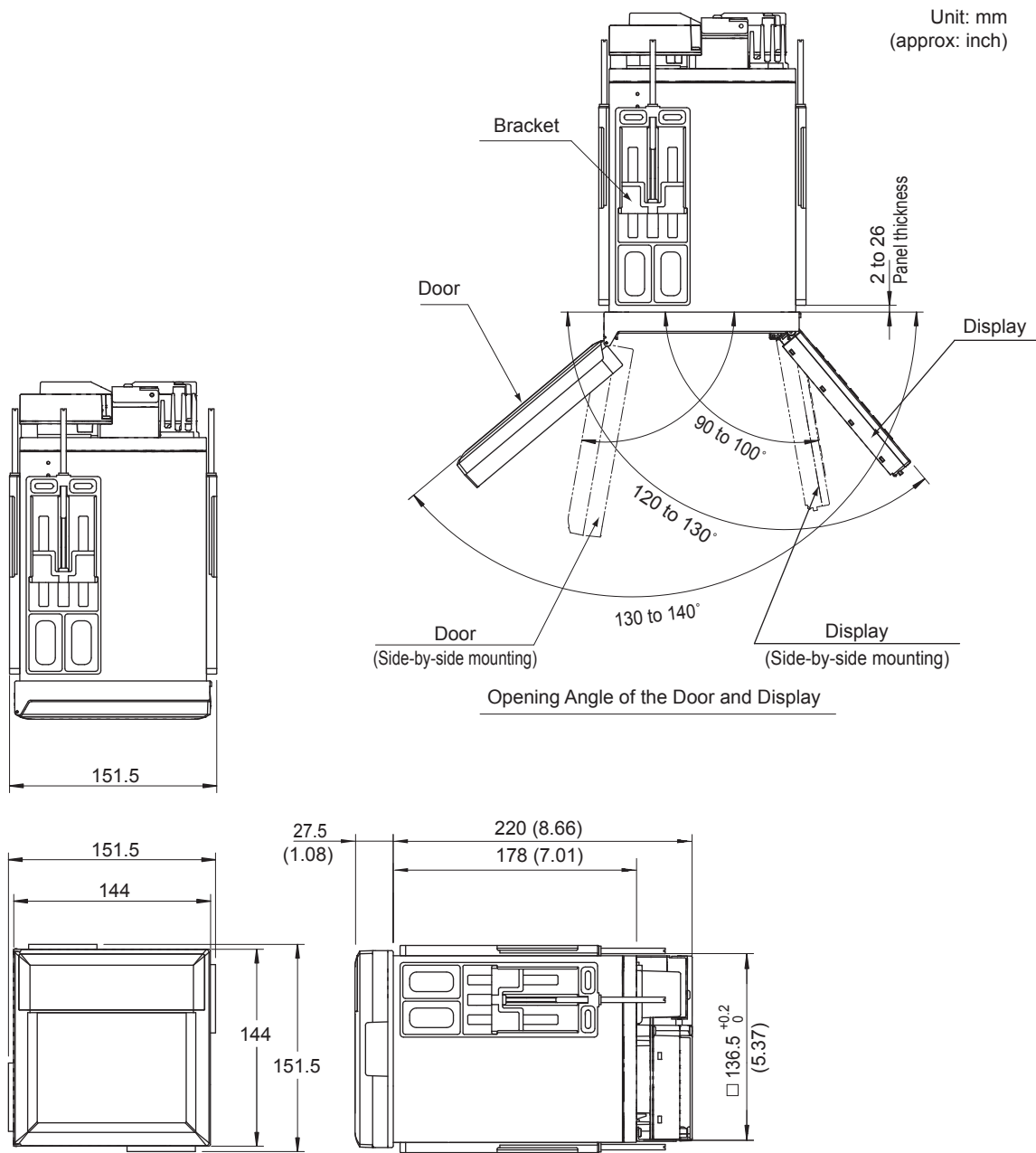

Note: If not specified, the tolerance is $\pm 3\%$. However, in case of less than 10 mm the tolerance is ± 0.3 mm.

F05.ai

PANEL CUTOUT & SPACING

Unit: mm
(approx. inch)

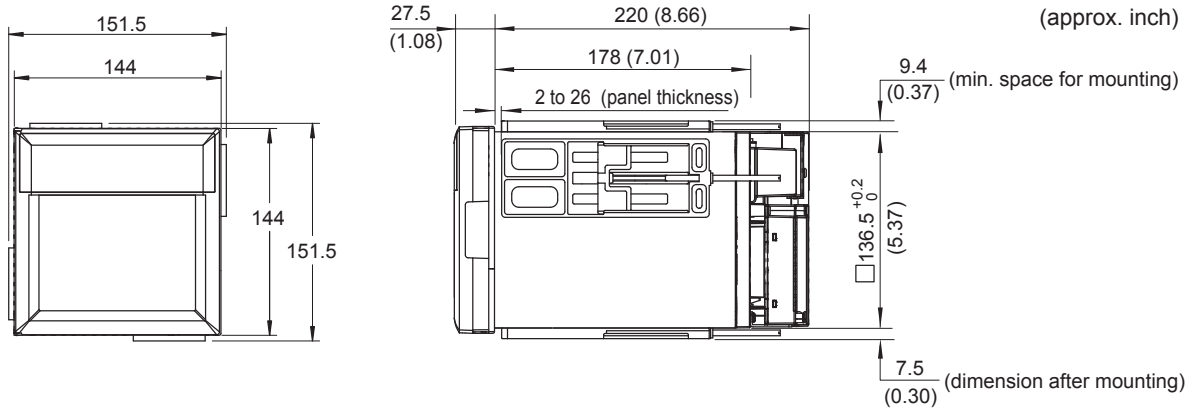

Note: The μ R10000 should be mounted by only two brackets, either on the top & bottom of the recorder, or on the left & right side of the recorder.

Single-Unit Mounting

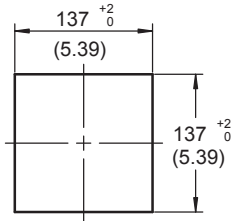

Side-by-Side Mounting (horizontally)

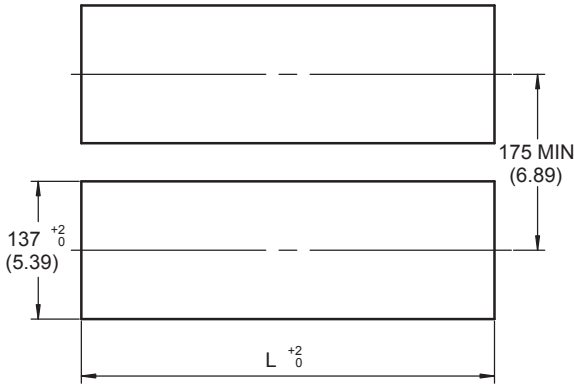

Side-by-Side Mounting (vertically, max. 3 units)

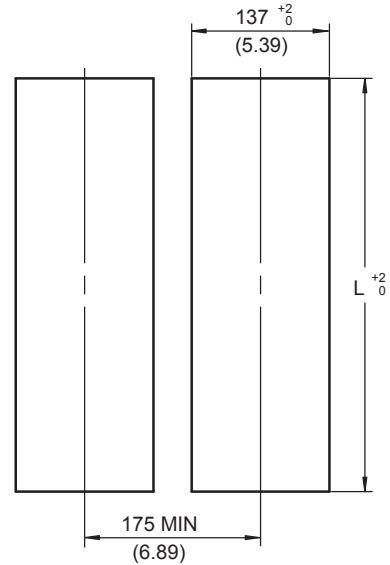

Units	L ⁺² / ₀ (mm)
2	282
3	426
4	570
5	714
6	858
7	1002
8	1146
9	1290
10	1434
n	(144 x n) - 6

Weight:
 4361 01: 2.1kg
 4361 02: 2.2kg
 4361 03: 2.3kg
 4361 04: 2.4kg
 4361 06: 2.5kg

Note: If not specified, the tolerance is 3%. However, in cases of less than 10 mm, the tolerance is 0.3 mm.

F06.ai

DIMENSION (Portable Type)

Unit: mm
(approx. inch)

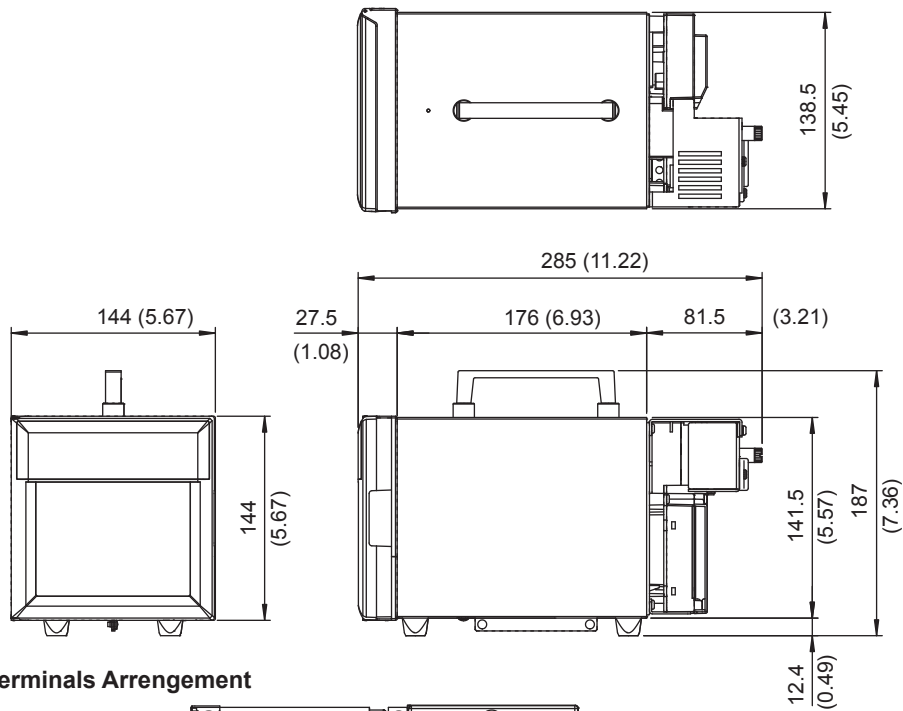

Terminals Arrangement

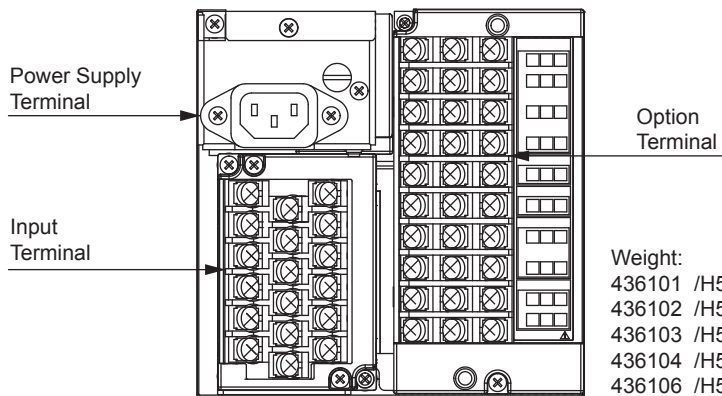

Note: make sure to use the appropriate power cord, matching the power outlet.
If not specified, the tolerance is $\pm 3\%$. However, in cases of less than 10 mm, the tolerance is ± 0.3 mm.

F07.ai

NOTE: Compatibility with Input Terminals and Option Terminals of Older Models

The input and option terminals of this instrument are specific to this instrument. Do not connect to the input terminals or option terminals of the $\mu R1000$, or other models as malfunction can result.

Relationship between Bezel Height of Peripheral Equipment and Space between Measurement Instruments

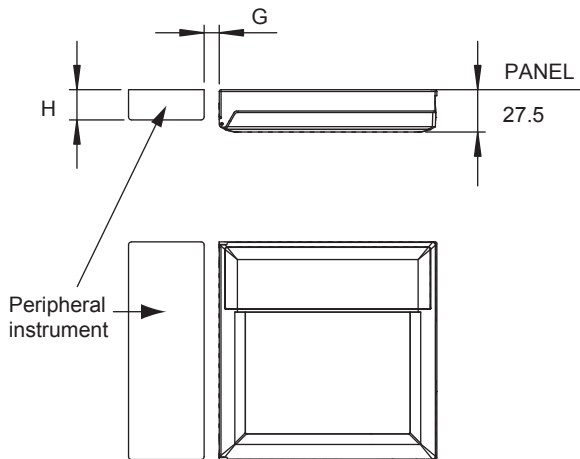

(In case mounted at the left side of $\mu R10000$)

Height of Bezel from Panel Less than H (mm)	Space More than G (mm)
20	0
24	1
28	2
32	3
More than 36 unlimited	4

Note: For instruments which do not have taper and angle R

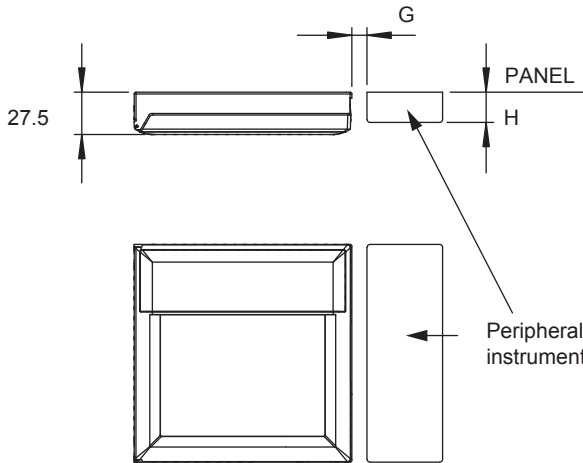

(In case mounted at the right side of $\mu R10000$)

Height of Bezel from Panel ; H (mm)	Space ; G (mm)
less than 23.5	0
more than 23.5	more than 3

Note: For instruments which do not have taper and angle R

Spacing for $\mu R10000$ and YS1000 when Mounted together

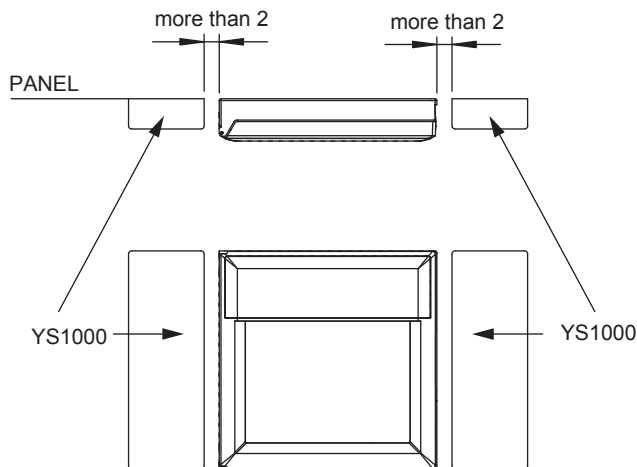

Mounting Place	Space ; G (mm)
Mount at the right side of YS1000	more than 2
Mount at the left side of YS1000	more than 2

F08.ai