

User Guide

Vaisala Indigo compatible
humidity and temperature probes

HMP Series with MMP8 and TMP1

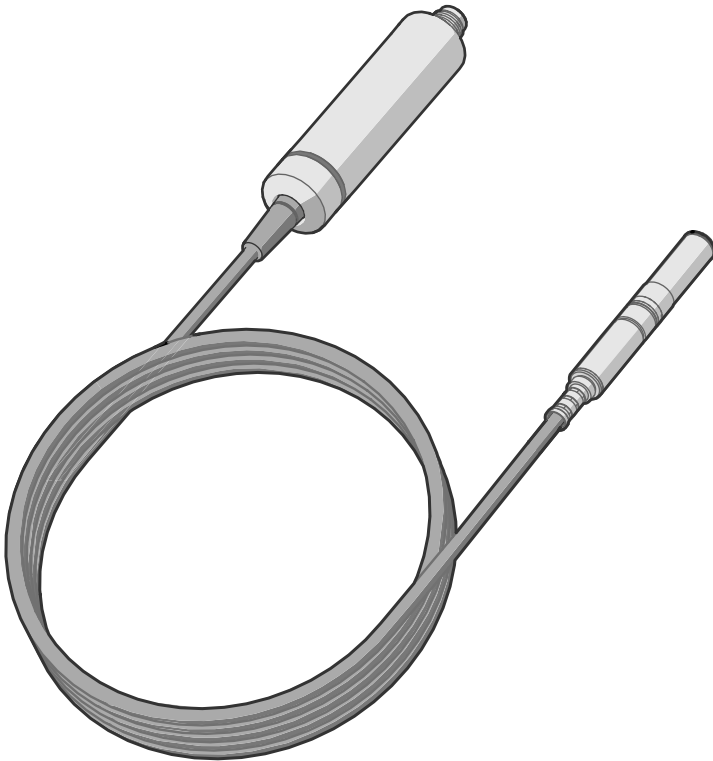

VAISALA

PUBLISHED BY

Vaisala Oyj
Vanha Nurmijärventie 21, FI-01670 Vantaa, Finland
P.O. Box 26, FI-00421 Helsinki, Finland
+358 9 8949 1

Visit our Internet pages at www.vaisala.com.

© Vaisala 2021

No part of this document may be reproduced, published or publicly displayed in any form or by any means, electronic or mechanical (including photocopying), nor may its contents be modified, translated, adapted, sold or disclosed to a third party without prior written permission of the copyright holder. Translated documents and translated portions of multilingual documents are based on the original English versions. In ambiguous cases, the English versions are applicable, not the translations.

The contents of this document are subject to change without prior notice.

Local rules and regulations may vary and they shall take precedence over the information contained in this document. Vaisala makes no representations on this document's compliance with the local

rules and regulations applicable at any given time, and hereby disclaims any and all responsibilities related thereto.

This document does not create any legally binding obligations for Vaisala towards customers or end users. All legally binding obligations and agreements are included exclusively in the applicable supply contract or the General Conditions of Sale and General Conditions of Service of Vaisala.

This product contains software developed by Vaisala or third parties. Use of the software is governed by license terms and conditions included in the applicable supply contract or, in the absence of separate license terms and conditions, by the General License Conditions of Vaisala Group.

Table of contents

1.	About this document	9
1.1	Version information.....	9
1.2	Related manuals.....	10
1.3	Documentation conventions.....	10
1.4	Trademarks.....	11
2.	Product overview	12
2.1	Probe structure.....	12
2.2	Basic features and options.....	12
2.3	Output parameters.....	13
2.4	Additional features with Indigo transmitters.....	14
2.5	Safety.....	15
2.6	ESD protection.....	15
2.7	Regulatory statements.....	15
2.7.1	FCC Part 15 compliance statement.....	15
2.7.2	Canada ICES-003 compliance statement.....	16
3.	Functional description	17
3.1	HUMICAP technology.....	17
3.2	Chemical purge.....	17
3.3	Condensation prevention functions.....	18
4.	Installation	20
4.1	Probe holder ASM213582.....	21
4.1.1	Mounting the probe body using probe holder ASM213582.....	21
4.2	Wiring.....	22
4.3	HMP1 probe.....	23
4.4	HMP3 probe.....	24
4.5	HMP4 probe.....	25
4.6	HMP5 probe.....	26
4.7	HMP7 probe.....	27
4.8	HMP8 probe.....	29
4.8.1	Attaching ball valve kit to process.....	30
4.9	HMP9 probe.....	31
4.9.1	Installing HMP9 through a cable gland.....	32
4.9.2	Overview of HMP9 Duct Installation Kit.....	33
4.9.3	Mounting HMP9 probe head with Duct Installation Kit.....	34
4.10	MMP8 probe.....	36
4.11	TMP1 probe.....	37
4.12	DTR502B solar radiation shield.....	37
4.12.1	Mounting probe head inside DTR502B.....	38
5.	Configuration with Insight software	41
5.1	Vaisala Insight software.....	41
5.2	Connecting to Insight software.....	41
5.3	Configuration options.....	42

5.4	Configuring condensation prevention.....	42
5.5	Diagnostics in Insight.....	43
6.	Using probe with Indigo transmitters.....	45
6.1	Indigo200 series transmitters.....	45
6.1.1	Attaching probe to Indigo200 series transmitter.....	47
6.2	Indigo500 series transmitters.....	48
7.	Maintenance.....	49
7.1	Cleaning the probe.....	49
7.1.1	Chemical tolerance.....	49
7.2	Changing the probe filter.....	50
7.3	Replacing the HUMICAP® R2 sensor.....	50
7.4	Calibration and adjustment.....	52
7.4.1	Adjustment points and requirements.....	53
7.4.2	HMK15 Humidity Calibrator with HMP Series probes	53
7.4.3	Adjusting measurement with Insight software.....	55
7.4.4	Adjusting measurement with Indigo200 series transmitter.....	56
8.	Troubleshooting.....	61
8.1	Problem situations.....	61
8.2	Error messages.....	61
8.3	Restoring factory default settings.....	63
9.	Technical data.....	64
9.1	HMP1 specifications.....	64
9.2	HMP3 specifications.....	67
9.3	HMP4 specifications.....	70
9.4	HMP5 specifications.....	74
9.5	HMP7 specifications.....	77
9.6	HMP8 specifications.....	81
9.7	HMP9 specifications.....	85
9.8	MMP8 specifications.....	89
9.9	TMP1 specifications.....	91
9.10	Accessories and spare parts.....	94
Appendix A:	Modbus reference.....	99
A.1	Default communication settings.....	99
A.2	Function codes.....	99
A.3	Data encoding.....	99
A.3.1	32-bit floating point or 32-bit integer format.....	100
A.3.2	16-bit integer format.....	100
A.4	Modbus registers.....	101
A.4.1	Measurement data registers.....	101
A.4.2	Configuration registers.....	104
A.4.3	Status registers.....	107
A.4.4	Test value registers.....	108
A.5	Device identification objects.....	108

A.6	Exception responses.....	109
A.7	Modbus communication examples.....	110
	Maintenance and calibration services.....	113
	Warranty.....	113
	Technical support.....	113
	Recycling.....	113

List of figures

Figure 1	Probe parts.....	12
Figure 2	Example installation.....	20
Figure 3	Probe holder ASM213582 dimensions.....	21
Figure 4	M12 5-pin A-coded male connector pinout.....	22
Figure 5	RS-485 wiring.....	23
Figure 6	HMP1 probe dimensions.....	23
Figure 7	HMP3 probe dimensions.....	24
Figure 8	HMP4 probe dimensions.....	25
Figure 9	HMP5 probe dimensions.....	26
Figure 10	Optional mounting flange 210696 dimensions.....	26
Figure 11	HMP7 probe dimensions.....	27
Figure 12	HMP8 probe dimensions.....	29
Figure 13	HMP9 probe dimensions.....	31
Figure 14	Installing HMP9 probe head through a cable gland.....	32
Figure 15	Duct Installation Kit ASM214055 dimensions.....	33
Figure 16	Duct installation overview.....	34
Figure 17	MMP8 dimensions.....	36
Figure 18	TMP1 probe dimensions.....	37
Figure 19	DTR502B dimensions.....	38
Figure 20	Mounting DTR502B on a pole mast.....	39
Figure 21	HMP9 probe head with sensor head support 215130.....	40
Figure 22	Connecting probe to Insight using Indigo USB adapter.....	41
Figure 23	HMP5 in Insight software.....	42
Figure 24	HMP5 diagnostics in Insight (advanced mode).....	44
Figure 25	Probe attached to Indigo200 series transmitter directly.....	45
Figure 26	Probe attached to Indigo200 series transmitter with a cable.....	46
Figure 27	Attaching the probe to Indigo200 series transmitter.....	47
Figure 28	Attaching probes to Indigo500 transmitter.....	48
Figure 29	HMP3 probe head with filter removed.....	51
Figure 30	HMP5 calibration with HMK15 using 211302SP adapter.....	54
Figure 31	Using HMP9 calibration adapter with HMK15.....	55
Figure 32	Calibration page in the Indigo200 wireless configuration interface.....	59
Figure 33	HMP1 humidity measurement accuracy as a function of temperature.....	64
Figure 34	HMP1 temperature measurement accuracy over full range.....	65
Figure 35	HMP1 probe dimensions.....	66
Figure 36	HMP3 humidity measurement accuracy as a function of temperature.....	68
Figure 37	HMP3 temperature measurement accuracy over full range.....	68
Figure 38	HMP3 probe dimensions.....	70
Figure 39	HMP4 humidity measurement accuracy as a function of temperature.....	71
Figure 40	HMP4 temperature measurement accuracy over full range.....	71
Figure 41	HMP4 probe dimensions.....	73

Figure 42	HMP5 humidity measurement accuracy as a function of temperature.....	75
Figure 43	HMP5 temperature measurement accuracy over full range.....	75
Figure 44	HMP5 probe dimensions.....	77
Figure 45	HMP7 humidity measurement accuracy as function of temperature.....	78
Figure 46	HMP7 temperature measurement accuracy over full range.....	79
Figure 47	HMP7 probe dimensions.....	81
Figure 48	HMP8 humidity measurement accuracy as a function of temperature.....	82
Figure 49	HMP8 temperature measurement accuracy over full range.....	82
Figure 50	HMP8 probe dimensions.....	84
Figure 51	Optional ball valve installation kit dimensions.....	85
Figure 52	HMP9 humidity measurement accuracy as a function of temperature.....	86
Figure 53	HMP9 temperature measurement accuracy over full range.....	86
Figure 54	HMP9 probe dimensions.....	88
Figure 55	MMP8 A _w measurement accuracy.....	89
Figure 56	MMP8 dimensions.....	91
Figure 57	TMP1 temperature measurement accuracy over full range.....	92
Figure 58	TMP1 probe dimensions.....	94
Figure 59	Optional duct kit 215003 dimensions.....	94

List of tables

Table 1	Document versions (English).....	9
Table 2	Related manuals.....	10
Table 3	Availability of output parameters.....	13
Table 4	Suitability of cleaning agents.....	49
Table 5	Troubleshooting table.....	61
Table 6	HMP1 measurement performance.....	64
Table 7	HMP1 operating environment.....	65
Table 8	HMP1 inputs and outputs.....	65
Table 9	HMP1 output parameters.....	65
Table 10	HMP1 compliance.....	66
Table 11	HMP1 mechanical specifications.....	66
Table 12	HMP3 measurement performance.....	67
Table 13	HMP3 operating environment.....	68
Table 14	HMP3 inputs and outputs.....	69
Table 15	HMP3 output parameters.....	69
Table 16	HMP3 compliance.....	69
Table 17	HMP3 mechanical specifications.....	69
Table 18	HMP4 measurement performance.....	70
Table 19	HMP4 operating environment.....	72
Table 20	HMP4 inputs and outputs.....	72
Table 21	HMP4 output parameters.....	72
Table 22	HMP4 compliance.....	73
Table 23	HMP4 mechanical specifications.....	73
Table 24	HMP5 measurement performance.....	74
Table 25	HMP5 operating environment.....	75
Table 26	HMP5 inputs and outputs.....	76
Table 27	HMP5 output parameters.....	76
Table 28	HMP5 compliance.....	76
Table 29	HMP5 mechanical specifications.....	76
Table 30	HMP7 measurement performance.....	77
Table 31	HMP7 operating environment.....	79
Table 32	HMP7 inputs and outputs.....	79
Table 33	HMP7 output parameters.....	79
Table 34	HMP7 compliance.....	80
Table 35	HMP7 mechanical specifications.....	80
Table 36	HMP8 measurement performance.....	81
Table 37	HMP8 operating environment.....	83
Table 38	HMP8 inputs and outputs.....	83
Table 39	HMP8 output parameters.....	83
Table 40	HMP8 compliance.....	84
Table 41	HMP8 mechanical specifications.....	84
Table 42	HMP9 measurement performance.....	85
Table 43	HMP9 operating environment.....	86
Table 44	HMP9 inputs and outputs.....	87
Table 45	HMP9 output parameters.....	87

Table 46	HMP9 compliance.....	87
Table 47	HMP9 mechanical specifications.....	88
Table 48	MMP8 measurement performance.....	89
Table 49	MMP8 operating environment.....	89
Table 50	MMP8 inputs and outputs.....	90
Table 51	MMP8 compliance.....	90
Table 52	MMP8 mechanical specifications.....	90
Table 53	TMP1 measurement performance.....	91
Table 54	TMP1 operating environment.....	92
Table 55	TMP1 inputs and outputs.....	92
Table 56	TMP1 compliance.....	93
Table 57	TMP1 mechanical specifications.....	93
Table 58	Connection cables.....	95
Table 59	HMP3 accessories.....	95
Table 60	HMP3 spare parts.....	95
Table 61	HMP4 spare parts.....	96
Table 62	HMP5 accessories.....	96
Table 63	HMP5 spare parts.....	96
Table 64	HMP7 accessories.....	96
Table 65	HMP7 spare parts.....	97
Table 66	HMP8 accessories.....	97
Table 67	HMP8 spare parts.....	97
Table 68	HMP9 accessories.....	97
Table 69	MMP8 accessories.....	98
Table 70	MMP8 spare parts.....	98
Table 71	TMP1 accessories.....	98
Table 72	Default Modbus serial communication settings.....	99
Table 73	Modbus function codes.....	99
Table 74	Interpretation of 16-bit signed integer values.....	100
Table 75	Floating point measurement data registers (read-only).....	101
Table 76	Integer measurement data registers (read-only).....	103
Table 77	Modbus configuration data registers (writable).....	104
Table 78	Modbus status data registers (read-only).....	107
Table 79	Error codes in register 0203 _{hex}	108
Table 80	Modbus test registers (read-only).....	108
Table 81	Device identification objects.....	108
Table 82	Modbus exception responses.....	109

1. About this document

1.1 Version information

This document provides instructions for installing, using, and maintaining Vaisala HUMICAP® Humidity and Temperature Probes HMP1, HMP3, HMP4, HMP5, HMP7, HMP8, HMP9, Moisture in Oil Probe MMP8, and Temperature Probe TMP1.

Table 1 Document versions (English)

Document code	Date	Description
M212022EN-F	March 2021	<p>Applicable from software version 1.2.0 onward. Added content for HMP1 probe model and updated technical data for all models.</p> <p>Added sections:</p> <ul style="list-style-type: none"> • HUMICAP technology (page 17) • Chemical purge (page 17) • Condensation prevention functions (page 18) • Mounting the probe body using probe holder ASM213582 (page 21) • Configuring condensation prevention (page 42) • HMK15 Humidity Calibrator with HMP Series probes (page 53) <p>Updated sections:</p> <ul style="list-style-type: none"> • Product overview (page 12) • Probe structure (page 12) • Output parameters (page 13) • Installation (page 20) • HMP7 probe (page 27) • Indigo200 series transmitters (page 45) • Indigo500 series transmitters (page 48) • Vaisala Insight software (page 41) • Problem situations (page 61) • Restoring factory default settings (page 63) • Measurement data registers (page 101) • Configuration registers (page 104) • Status registers (page 107)

Document code	Date	Description
M212022EN-E	June 2020	<p>Added sections:</p> <ul style="list-style-type: none"> • DTR502B solar radiation shield (page 37) • Mounting probe head inside DTR502B (page 38) • Diagnostics in Insight (page 43) • Indigo500 series transmitters (page 48) • Exception responses (page 109) • Maintenance and calibration services (page 113) <p>Updated sections:</p> <ul style="list-style-type: none"> • Additional features with Indigo transmitters (page 14) • Using probe with Indigo transmitters (page 45) • Corrected CRC values in section Modbus communication examples (page 110)
M212022EN-D	March 2020	Added content for HMP3 and MMP8 probe models.

1.2 Related manuals

Table 2 Related manuals

Document code	Name
M211982EN	<i>HMP Series with MMP8 and TMP1 Quick Guide</i>
M211877EN	<i>Indigo201 Analog Output Transmitter User Guide</i>
M211966EN	<i>Indigo202 Digital Transmitter User Guide</i>
M212287EN	<i>Indigo520 Transmitter User Guide</i>

1.3 Documentation conventions



WARNING! Warning alerts you to a serious hazard. If you do not read and follow instructions carefully at this point, there is a risk of injury or even death.



CAUTION! Caution warns you of a potential hazard. If you do not read and follow instructions carefully at this point, the product could be damaged or important data could be lost.



Note highlights important information on using the product.



Tip gives information for using the product more efficiently.



Lists tools needed to perform the task.



Indicates that you need to take some notes during the task.

1.4 Trademarks

Vaisala® and HUMICAP® are registered trademarks of Vaisala Oyj.

Modbus® is a registered trademark of Schneider Automation Inc.

All other product or company names that may be mentioned in this publication are trade names, trademarks, or registered trademarks of their respective owners.

2. Product overview

HMP series probes are humidity and temperature measurement probes with a digital output (Modbus® protocol). The probes are designed for demanding humidity and temperature measurement applications. The probes have a two-part structure, with measurement electronics contained in the probe body and sensor(s) in the probe head. The probe body and the probe head are connected by a cable, except on the HMP1 model. Length options for this connecting cable depend on the probe model.

The probes are compatible with Vaisala Indigo transmitters. They can also be connected to Vaisala Insight software for configuration, calibration, adjustment, diagnostics, and temporary online monitoring.

2.1 Probe structure

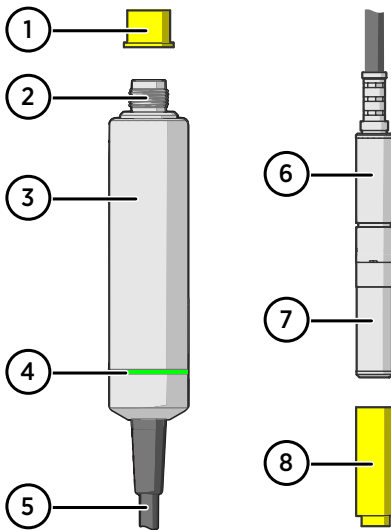

Figure 1 Probe parts

- 1 Protection cap (remove before use)
- 2 5-pin M12 connector
- 3 Probe body with type label
- 4 Status indicator LED:
 - Green Power on and probe online, flashes when communicating
 - Red Error
 - Off Power off, or indicator disabled
- 5 Probe cable. HMP1 model does not have a probe cable, as its probe head is directly attached to the probe body.
- 6 Probe head (HMP7 model shown)
- 7 Location of sensor(s) on the probe head. Other probe models have a removable filter over the sensors but HMP1, HMP9, and TMP1 do not.
- 8 Protection cap (remove before use)



To prevent the warming of the indicator LED from causing a slight measurement error, HMP1 keeps the indicator normally off (even when power is on). If the probe is in error state, the red LED is shown.

2.2 Basic features and options

- Comprehensive list of output parameters. See [Output parameters \(page 13\)](#).

- Sensor purge provides superior chemical resistance (HMP models only)
- Condensation prevention feature minimizes condensation on probe (HMP models with composite sensors only)
- Traceable calibration certificate:
 - HMP and MMP models: 6 points for humidity, 1 point for temperature
 - TMP1: 2 points for temperature
- Standalone Modbus® RTU over RS-485
- Compatible with Indigo series of transmitters
- Can be connected to Vaisala Insight PC software for configuration, calibration, diagnostics, and temporary online monitoring

2.3 Output parameters



On HMP probe models, the values of all available output parameters are locked when the sensor is being warmed by the chemical purge function.

- Output parameter is available on this model.
- Output parameter is available on this model, but its value is unavailable when condensation prevention functions are warming the sensor. Writing temperature to Modbus register 0334_{hex} from an external source makes the output value available during condensation prevention.
- Output parameter is not available on this model.

Table 3 Availability of output parameters

Output parameter	Output unit	HMP1, 3, 4, 5, 7, 8, and 9	MMP8	TMP1
Absolute humidity	g/m ³	○	–	–
Absolute humidity at NTP	g/m ³	○	–	–
Dew/frost point temperature	°C	●	–	–
Dew/frost point temperature at 1 atm	°C	●	–	–
Dew point temperature	°C	●	–	–
Dew point temperature at 1 atm	°C	●	–	–
Dew point temperature difference	°C	○	–	–
Enthalpy	kJ/kg	○	–	–
Mixing ratio	g/kg	●	–	–
Relative humidity	%RH	○	–	–
Relative humidity (dew/frost)	%RH	○	–	–
Relative saturation	%RS	–	●	–

Output parameter	Output unit	HMP1, 3, 4, 5, 7, 8, and 9	MMP8	TMP1
Temperature	°C	●	●	●
Water activity	-	-	●	-
Water concentration	ppm _v	●	-	-
Water concentration in oil	ppm _v	-	●	-
Water concentration (wet basis)	vol-%	●	-	-
Water mass fraction	ppm _w	●	-	-
Wet-bulb temperature	°C	●	-	-
Water vapor pressure	hPa	●	-	-
Water vapor saturation pressure	hPa	●	-	●

2.4 Additional features with Indigo transmitters

Connecting the probe to an Indigo transmitter provides a wide range of additional options for outputs, measurement viewing, status monitoring, and configuration interface access.

Examples of additional features available with Indigo500 series transmitters:

- Touchscreen display for real-time data viewing and configuration
- Support for 2 probes simultaneously
- 4 configurable analog outputs
- 2 configurable relays
- Ethernet connection with web interface for remote access
- Modbus TCP/IP protocol

Examples of additional features available with Indigo200 series transmitters:

- 3.5" TFT LCD color display or non-display model with LED indicator
- Digital output or 3 analog outputs (depending on the transmitter model)
- 2 configurable relays
- Wireless browser-based configuration interface for mobile devices and computers (IEEE 802.11 b/g/n WLAN)



Available features vary depending on the Indigo transmitter model. For more information on Indigo transmitters, see www.vaisala.com/indigo.

2.5 Safety



WARNING! When returning a product for calibration or repair, make sure it has not been exposed to dangerous contamination, and is safe to handle without special precautions.



CAUTION! Do not attempt to open the probe body. There are no user serviceable parts inside the probe body.



CAUTION! Do not touch the probe head with your bare hands. Touching will deposit impurities on the probe head.



CAUTION! Be aware that the probe head may become hot to touch when condensation prevention heating or chemical purge functions are active.

2.6 ESD protection

Electrostatic discharge (ESD) can cause immediate or latent damage to electronic circuits. Vaisala products are adequately protected against ESD for their intended use. However, it is possible to damage the product by delivering an electrostatic discharge when touching, removing or inserting any objects inside the equipment housing.

Avoid touching component contacts or connectors when working with the device.

2.7 Regulatory statements

2.7.1 FCC Part 15 compliance statement

This equipment has been tested and found to comply with the limits for a Class B digital device, pursuant to Part 15 of the FCC rules. These limits are designed to provide reasonable protection against harmful interference in a residential installation. This equipment generates, uses and can radiate radio frequency energy and, if not installed and used in accordance with the instructions, may cause harmful interference to radio communications. However, there is no guarantee that the interference will not occur in a particular installation. If this equipment does cause harmful interference to radio or television reception, which can be determined by turning the equipment off and on, the user is encouraged to try to correct the interference by one or more of the following measures:

- Reorient or relocate the receiving antenna.

- Increase the separation between the equipment and receiver.
- Connect the equipment into an outlet on a circuit different from that to which the receiver is connected.
- Consult the dealer or an experienced radio/TV technician for help.



CAUTION! Changes or modifications to this equipment not expressly approved by the party responsible for compliance could void the user's authority to operate the equipment.



This device complies with part 15 of the FCC Rules. Operation is subject to the following two conditions: (1) This device may not cause harmful interference, and (2) this device must accept any interference received, including interference that may cause undesired operation.

2.7.2 Canada ICES-003 compliance statement

This Class B digital apparatus complies with Canadian ICES-003.

Cet appareil numérique de la classe B est conforme à la norme NMB-003 du Canada.

3. Functional description

3.1 HUMICAP technology

Vaisala HUMICAP® is a capacitive thin-film polymer sensor consisting of a substrate on which a thin film of polymer is deposited between two conductive electrodes. The sensing surface is coated with a porous metal electrode to protect it from contamination and exposure to condensation. The substrate is typically glass or ceramic.

The thin-film polymer either absorbs or releases water vapor as the relative humidity of the measurement environment rises or falls. The dielectric properties of the polymer film depend on the amount of absorbed water. As the relative humidity around the sensor changes, the dielectric properties of the polymer film change, and so does the capacitance of the sensor. Capacitance is converted into a humidity reading. The HUMICAP sensor is complemented by a temperature sensor, which is bonded together with the capacitive polymer on some of the sensor variants. Additional output parameters such as dew point are calculated from the readings measured by the sensors.

HUMICAP sensors with bonded temperature sensors are also known as **composite sensors**. Probes with composite sensors can use the **chemical purge** function to maintain sensor performance. They also implement **condensation prevention** functions that are a key element in achieving an excellent stability and good condensation resistance in high humidity applications.

The integrated sensor arrangement on the HMP1 and HMP9 probes is different from the composite sensors used in the other HMP probes. However, they are also capable of using condensation prevention heating and chemical purge.

3.2 Chemical purge

Chemical purge heats the sensor to a high temperature, which evaporates excess molecules out of the sensor polymer. This minimizes the drift at the wet end of humidity readings, and removes contaminants from the sensor element. The heating phase is followed by a cooling phase where the sensor cools down to ambient temperature.

During chemical purge the values of the output parameters stay frozen at their last measured values. Chemical purge takes a few minutes to complete, after which measurement continues normally and updated values of output parameters are again available.

When ordered with chemical purge enabled, HMP model probes perform the purge at one day intervals (known as **interval purge**). If desired, chemical purge can also be performed when the probe is powered on (known as **startup purge**). Purge settings can be configured with Insight software or using Modbus protocol.



To allow the chemical purge to be completed in a reasonable time, it will not be started if the ambient temperature is below 0 °C (+32 °F).

3.3 Condensation prevention functions

Condensation prevention heating prevents water from condensing on the sensor and interfering with humidity measurement. Use of condensation prevention is controlled by a single setting that can be changed with Insight software or using Modbus protocol. The setting is only available if your probe supports condensation prevention.

By default, condensation prevention is off. However, the HMP7 model can be ordered from Vaisala with the feature enabled.

When condensation prevention is enabled, the probe will automatically use its available condensation prevention functions. When warming is active, values of output parameters that depend on temperature measurement (for example, relative humidity) are unavailable unless temperature is written to register 0334_{hex} from an external source. Output parameters that can be measured or calculated without this external temperature information, such as dew point temperature, are available even without the temperature input.

Sensor warming

Sensor warming is available to all HMP series probes with composite sensors, HMP1, and HMP9. Warms the humidity sensor when necessary to keep its temperature above the dew point of the measurement environment. When sensor warming is activated, all temperature dependent output parameters become unavailable unless external temperature information is provided to the probe. The output parameters become available again 4 minutes after the warming is stopped.



Sensor warming is intended for improving the condensation tolerance of the probe in measurement environments that may occasionally cause condensation to form. It is not intended for environments where continuous warming is needed.

Probe heating

Probe heating is available on HMP7 model only. Probe heating warms up the entire probe head instead of just the sensor. It is intended for use in challenging measurement environments where condensation on the probe would otherwise present a problem.

Probe heating always applies some heating power even when the sensor is not near condensation, so temperature-dependent output parameters are permanently unavailable when probe heating is used, unless external temperature information is provided to the probe.

If the ambient dew point rises close to current sensor temperature, the heating power is increased to avoid condensation. Heating power also increases as supply voltage increases.



If you use probe heating, be sure to mount the HMP7 probe head in a way that prevents the heat from being conducted away from the probe. Tightly connecting the HMP7 probe head to a metal structure may prevent the probe from maintaining probe temperature above the dew point. It will also heat the structure which may be undesirable.



Even if condensation prevention has been turned on, probe heating is not active if supply voltage is below 18 V DC. For example, this is the case when HMP7 probe is connected to Insight software using the Indigo USB Adapter.

More information

- [Configuring condensation prevention \(page 42\)](#)

4. Installation

When you choose the installation location for the probe, consider the following:

- Verify the operating environment specification of the probe model. The probe head typically has a much wider operating temperature range than the probe body.
- If the temperature of the measured environment differs greatly from ambient temperature, the entire probe head and preferably plenty of cable must be inside the measured environment. This prevents measurement inaccuracy caused by heat conduction along the cable.
- Probe mounting options are model-specific.

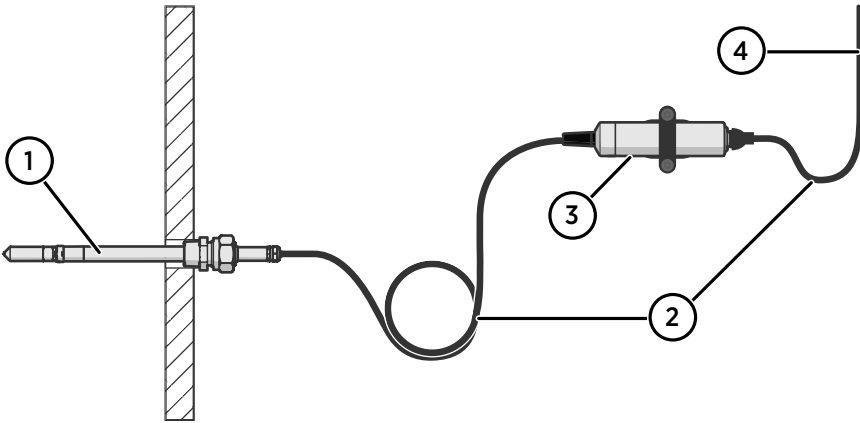

Figure 2 Example installation

- 1 Mount the probe head horizontally to prevent any water condensing on the probe head from running to the sensors.
- 2 Let the cable hang loosely to prevent condensed water from running along the cable to the probe body or probe head.
- 3 Attach the probe body to a wall or other surface using supplied probe holder (item code ASM213582).
- 4 Cable to Modbus master or Indigo transmitter.

More information

- [Default communication settings \(page 99\)](#)

4.1 Probe holder ASM213582

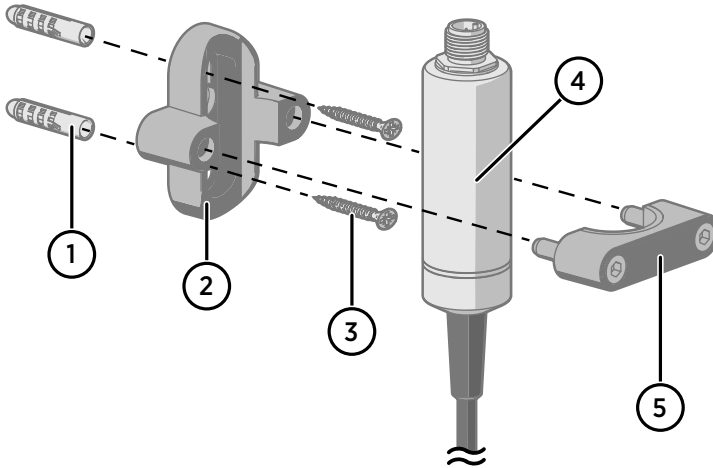

- 1 Wall plugs (2 pcs included, 6×30 nylon)
- 2 Base of the probe holder
- 3 Screws (2 pcs included, 4.8×25 DIN7981C PZ A4)
- 4 Ø 25 mm (0.98 in) probe body
- 5 Top of the probe holder with 2 hex screws (4-mm socket)

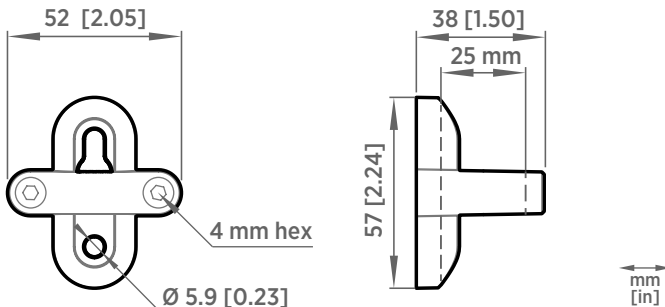

Figure 3 Probe holder ASM213582 dimensions

4.1.1 Mounting the probe body using probe holder ASM213582

Probe holder ASM213582 is designed for attaching a 25 mm probe body to a wall or other surface with screws.

- ▶ 1. Use a 4-mm Allen key to open the hex screws and remove the top part of the probe holder.
2. Hold the base part against the mounting surface and mark the locations of the 2 screw holes.
3. Drill holes at the marked locations using a 6-mm drill bit. Make the holes at least 30 mm deep.
4. Insert the wall plugs in the holes.
5. Mount the base part using screws.
6. Insert the probe body in the holder.
7. Place the top part on the base and tighten the hex screws with a 4-mm Allen key.

4.2 Wiring

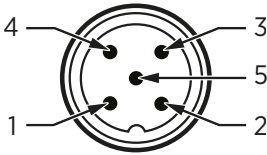

Figure 4 M12 5-pin A-coded male connector pinout

Pin #	Function	Notes	Wire colors in Vaisala cables
1	Power supply	Operating voltage: • HMP7: 18 ... 30 V DC • Other models: 15 ... 30 V DC Current consumption: 10 mA typical, 500 mA max.	Brown
2	RS-485 -		White
3	Power GND and RS-485 common		Blue
4	RS-485 +		Black
5	Not connected		Gray

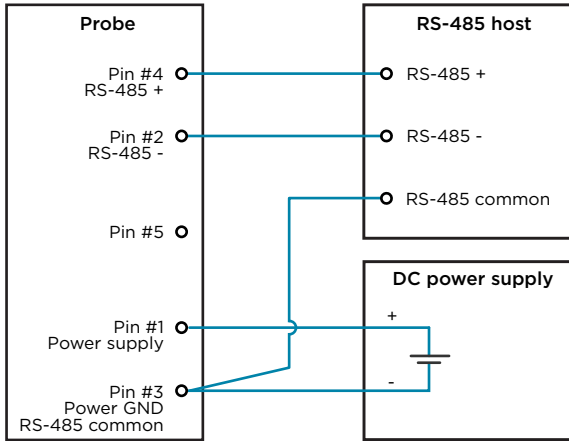

Figure 5 RS-485 wiring

i Recommended maximum length of the RS-485 line is 30 m (98 ft).

4.3 HMP1 probe

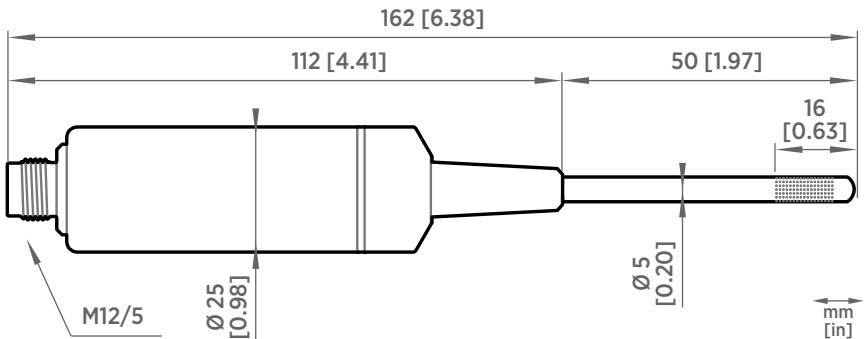



Figure 6 HMP1 probe dimensions

Vaisala HUMICAP® Humidity and Temperature Probe HMP1 is designed for ambient measurement in indoor spaces. Its probe head and body are integrated into a single unit with no cable between them. HMP1 can be directly connected to Indigo200 series transmitters to form a single wall-mounted unit.

See [Attaching probe to Indigo200 series transmitter \(page 47\)](#).

- Operating temperature -40 ... +60 °C (-40 ... +140 °F)
- Integrated filter (non-replaceable)



CAUTION! Do not damage the probe head by bending, crushing, or striking it.

4.4 HMP3 probe

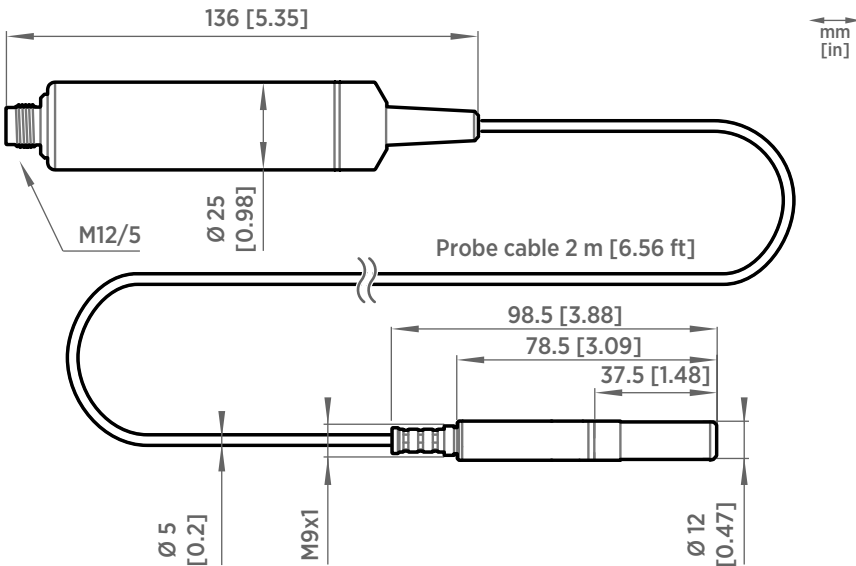

Figure 7 HMP3 probe dimensions

Vaisala HUMICAP® Humidity and Temperature Probe HMP3 is a general purpose probe designed for various industrial processes. The probe structure allows for replacing the sensor without tools, making it suitable for applications such as paint booths and other industrial applications where periodic recalibration alone is not sufficient for maintaining the probe performance. Other suitable applications include, for example, industrial HVAC systems, cleanrooms, and environmental chambers.

- Operating temperature for probe head -40 ... +120 °C (-40 ... +248 °F)
- Operating temperature for probe body -40 ... +80 °C (-40 ... +176 °F)

If purchased with a composite sensor instead of the field replaceable HUMICAP® R2 sensor, HMP3 can use the chemical purge feature. In environments with high concentrations of chemicals and cleaning agents, the chemical purge option helps to maintain measurement accuracy between calibration intervals.

More information

- [Mounting probe head inside DTR502B \(page 38\)](#)

4.5 HMP4 probe

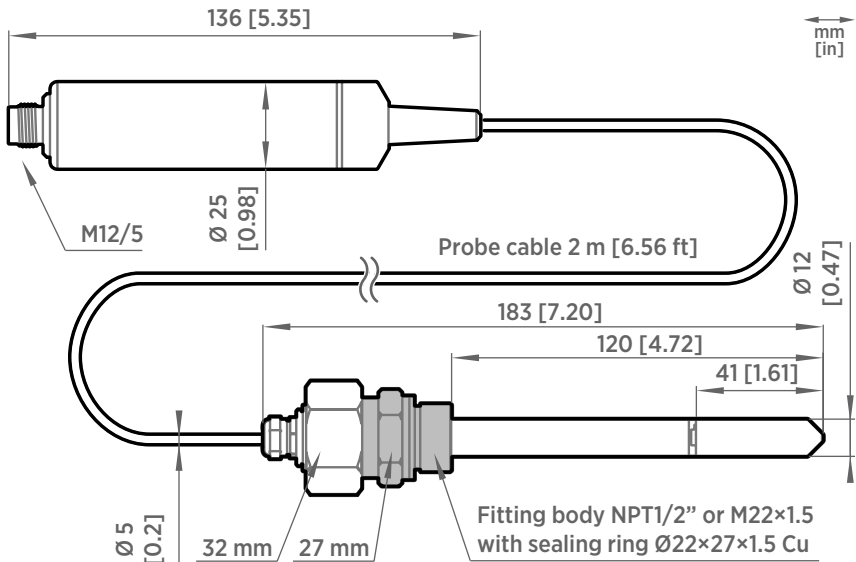

Figure 8 HMP4 probe dimensions

Vaisala HUMICAP® Humidity and Temperature Probe HMP4 is designed for high-pressure applications such as compressed air systems in maritime, breathing air, and industrial applications, where measurement performance and chemical tolerance are essential.

- Temperature measurement range $-70 \dots +180 \text{ }^\circ\text{C}$ ($-94 \dots +356 \text{ }^\circ\text{F}$)
- Operating pressure 0 ... 10 MPa (0 ... 100 bar)
- Operating temperature for probe body $-40 \dots +80 \text{ }^\circ\text{C}$ ($-40 \dots +176 \text{ }^\circ\text{F}$)
- M22x1.5 or NPT1/2" fitting body



Use a sealing ring ($\varnothing 22 \times 27 \times 1.5$ Cu) with the M22x1.5 fitting. Replace the sealing ring every time the probe is detached. Three sealing rings are supplied with the fitting.

4.6 HMP5 probe

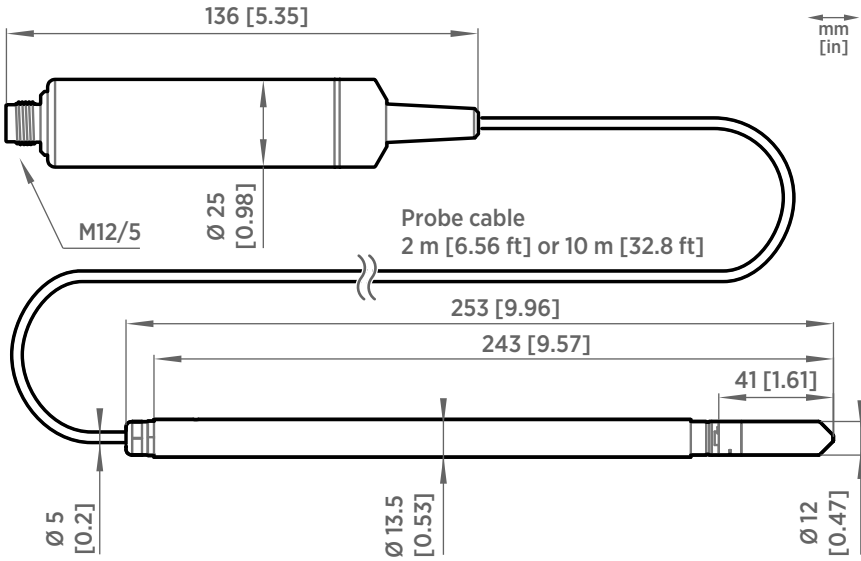

Figure 9 HMP5 probe dimensions

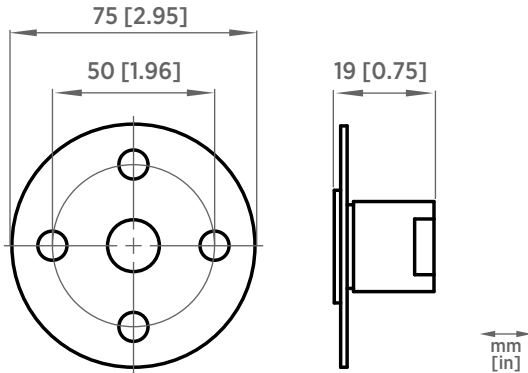

Figure 10 Optional mounting flange 210696 dimensions

Vaisala HUMICAP® Humidity and Temperature Probe HMP5 is designed for high-temperature applications such as baking ovens, pasta dryers, and industrial drying kilns, where measurement performance and chemical tolerance are essential.

- Temperature measurement range -70 ... +180 °C (-94 ... +356 °F)

- Operating temperature of probe body $-40 \dots +80 \text{ }^{\circ}\text{C}$ ($-40 \dots +176 \text{ }^{\circ}\text{F}$)
- 250-mm (9.84 in) probe allows easy process installation through insulation

4.7 HMP7 probe

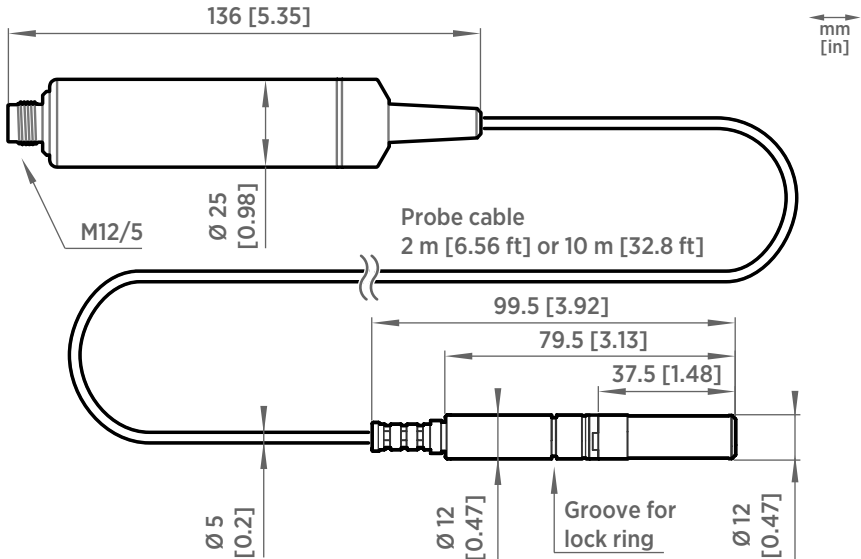

Figure 11 HMP7 probe dimensions

Vaisala HUMICAP® Humidity and Temperature Probe HMP7 is designed for applications that involve constant high humidity or rapid changes in humidity, such as drying and test chambers, combustion air, and other humidifiers and meteorological measurements, where measurement performance and chemical tolerance are essential.

- Temperature measurement range $-70 \dots +180 \text{ }^{\circ}\text{C}$ ($-94 \dots +356 \text{ }^{\circ}\text{F}$)
- Operating temperature of probe body $-40 \dots +80 \text{ }^{\circ}\text{C}$ ($-40 \dots +176 \text{ }^{\circ}\text{F}$)
- Condensation prevention with probe heating
- Vapor and pressure proof construction

Condensation prevention with probe heating

Condensation prevention on HMP7 uses a combination of probe heating and sensor warming. Probe heating keeps the entire probe head above the current dew point temperature, which prevents condensation from forming on the probe.

The values of output parameters that are dependent on temperature measurement (such as relative humidity) are unavailable when the probe is warming itself, unless the true temperature of the measured environment is updated to the temperature compensation register of the probe from another measurement instrument (for example, TMP1 model probe). Output parameters that can be measured or calculated without this external temperature information, such as dew point temperature, are available even without the temperature input.

Indigo500 transmitters support HMP7 temperature compensation from TMP1. For more information, see *Indigo520 User Guide (M212287EN)*.

HMP7 in fuel cell applications

Probe heating makes HMP7 ideal for use in fuel cell applications, specifically proton-exchange membrane fuel cells (PEMFC). Humidity measurements in fuel cell applications are performed in a high-humidity environment, typically over 80% relative humidity. Performing humidity measurements in hot, near-condensing environments is a challenging task, and the humidity sensor must be adequately protected against saturation to allow continuous measurement. Probe heating accomplishes just that.

HMP7 can be ordered from Vaisala with special settings that have been optimized for the fuel cell application. These settings include a faster probe heating control that allows the probe to quickly heat the probe to stay ahead of the rising dew point temperature.



WARNING! HMP7 is not designed for use in hazardous environments with potentially explosive atmospheres. Make sure no part of the probe is placed in a potentially explosive gas mixture.

More information

- [Mounting probe head inside DTR502B \(page 38\)](#)

4.8 HMP8 probe

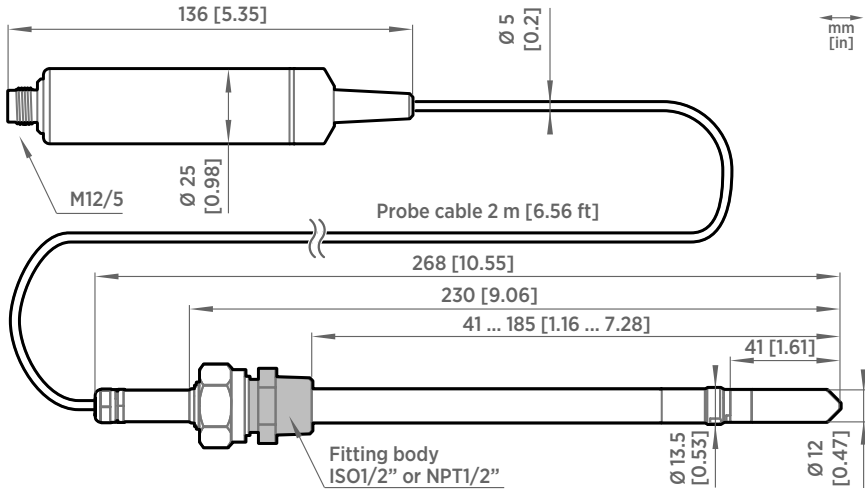
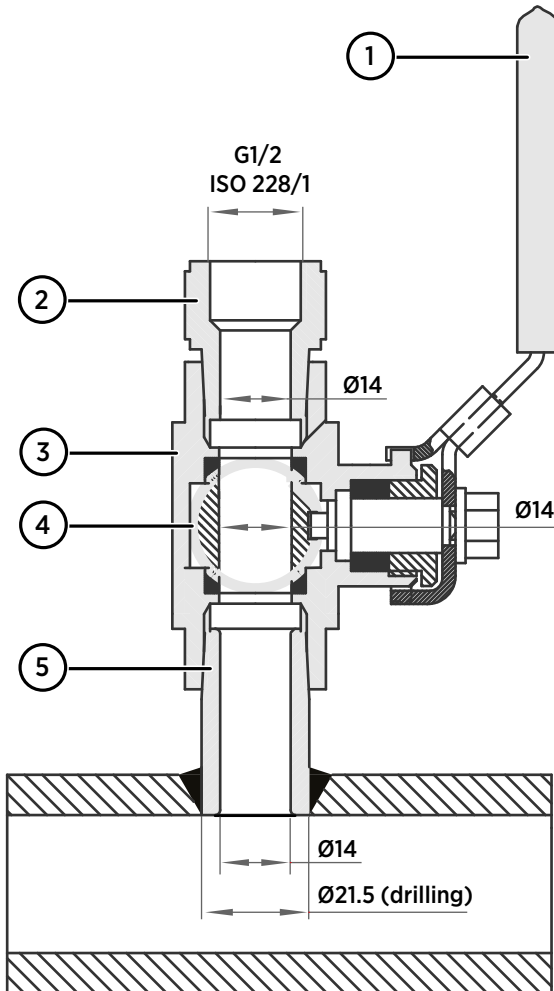

Figure 12 HMP8 probe dimensions

Vaisala HUMICAP® Humidity and Temperature Probe HMP8 is designed for pressurized applications in compressed air systems, refrigerant dryers, and other pressurized industrial applications, where easy insertion and removal of the probe and adjustable installation depth into the pipeline are needed.

- Temperature measurement range $-70 \dots +180 \text{ }^{\circ}\text{C}$ ($-94 \dots +356 \text{ }^{\circ}\text{F}$)
- Operating temperature of probe body $-40 \dots +80 \text{ }^{\circ}\text{C}$ ($-40 \dots +176 \text{ }^{\circ}\text{F}$)
- Operating pressure $0 \dots 4 \text{ MPa}$ ($0 \dots 40 \text{ bar}$)
- Probe installation depth can be freely adjusted and probe can be hot-swapped from pressurized pipelines with an installation valve
- ISO1/2" or NPT1/2" fitting body

4.8.1 Attaching ball valve kit to process



- 1 Ball valve handle: must point to the same direction as the ball valve body when installing.
- 2 Extension nipple, threads G1/2 ISO228/1 and R1/2 ISO7/1.
- 3 Ball valve body. When tightening the assembly, turn only from the ball valve body.
- 4 Ball of the ball valve.
- 5 Welding joint, threads R1/2 ISO7/1.

- ▶ 1. Attach the welding joint to the process pipe or chamber.
2. Apply a sealant (MEGA-PIPE EXTRA No. 7188 or LOCTITE® No. 542 with activator No. 7649) on the threads of the welding joint and screw the bottom of the ball valve onto the welding joint.
3. Tighten the ball valve assembly by turning from the ball valve body.



CAUTION! Tightening the ball valve kit by turning the extension nipple can break the sealing. Tighten the ball valve assembly only from the ball valve body.

4. If you need to cap the ball valve assembly before installing or after removing the probe, attach a blanking nut to close the top of the valve.

4.9 HMP9 probe

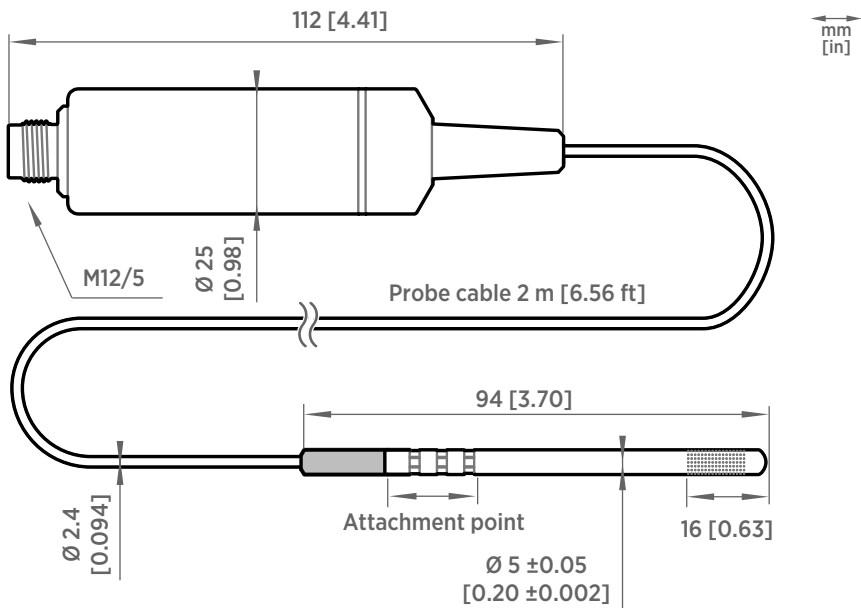

Figure 13 HMP9 probe dimensions

Vaisala HUMICAP® Humidity and Temperature Probe HMP9 is designed for easy installation into rapidly changing environments where fast response time, measurement performance, and chemical tolerance are essential.

The probe head can be mounted through thin metal walls using the included cable gland or mounting grommet. Two grommets are included: small one for 6.5 mm diameter hole, and large one for 12.5 mm diameter hole.

You can also attach the probe head directly using a zip tie. The probe head should be attached from the point near the black plastic part.

- Temperature measurement range $-40 \dots +120 \text{ }^\circ\text{C}$ ($-40 \dots +248 \text{ }^\circ\text{F}$)
- Operating temperature of probe body $-40 \dots +60 \text{ }^\circ\text{C}$ ($-40 \dots +140 \text{ }^\circ\text{F}$)
- Integrated filter (non-replaceable)



CAUTION! Do not damage the probe head by bending, crushing, or striking it. Avoid overtightening when installing the probe head through a cable gland.

More information

- [Mounting probe head inside DTR502B \(page 38\)](#)

4.9.1 Installing HMP9 through a cable gland

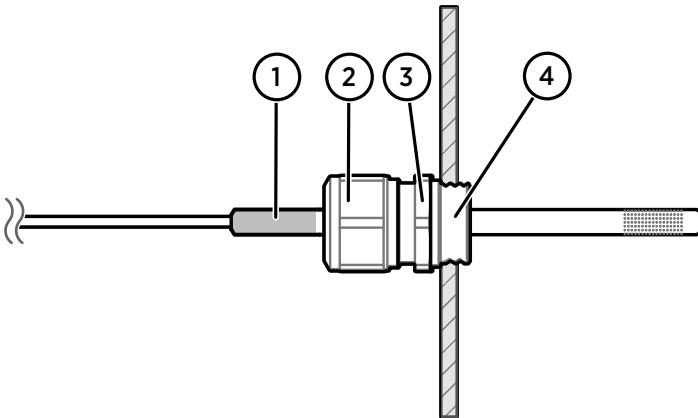

Figure 14 Installing HMP9 probe head through a cable gland

- 1 Black plastic part of the HMP9 probe head
- 2 Nut for tightening the probe in place
- 3 Base of the cable gland
- 4 M10×1.5 threads of the cable gland



- M10×1.5 cable gland (included with HMP9 probe)
- Drill with 8.5 mm bit
- M10×1.5 threading tap
- 13 mm wrench

- ▶ 1. Drill a 8.5 mm diameter hole in the installation location.
2. Use a threading tap to create a M10×1.5 thread in the hole.
3. Install the base of the cable gland in the hole and tighten with a 13 mm wrench.
4. Insert the seal of the cable gland in the base and place the nut of the cable gland over the probe head.
5. Insert the probe head in the cable gland up to the black plastic part of the probe head. Leave the black plastic part entirely outside the cable gland. Tighten the cable gland to finger tightness.
6. Tighten the nut of the cable gland with a 13 mm wrench until the probe head stops moving. Do not overtighten.

4.9.2 Overview of HMP9 Duct Installation Kit

Duct Installation Kit (Vaisala item ASM214055) is an optional accessory designed to support the probe head of a HMP9 Humidity and Temperature Probe in installations to ducts and chambers. The kit is lightweight and can be installed with minimal tools.

The kit does not include an attachment for the probe body of HMP9. To mount the probe body, use the probe holder supplied with HMP9, or attach it directly to a compatible Indigo transmitter.

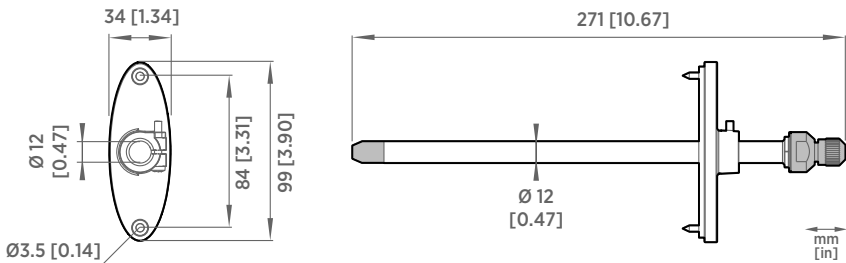

Figure 15 Duct Installation Kit ASM214055 dimensions

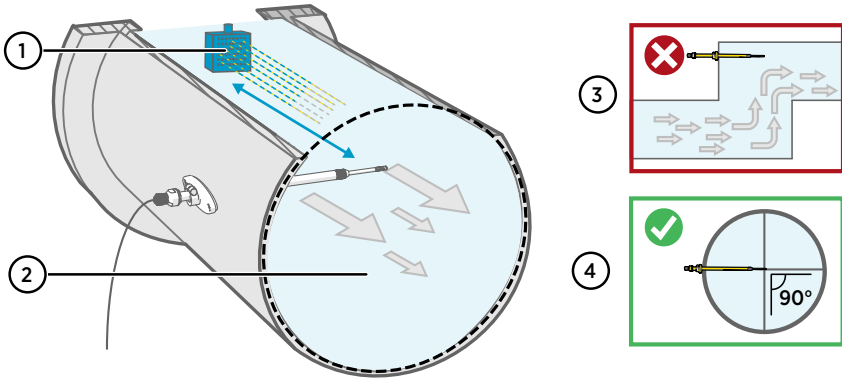
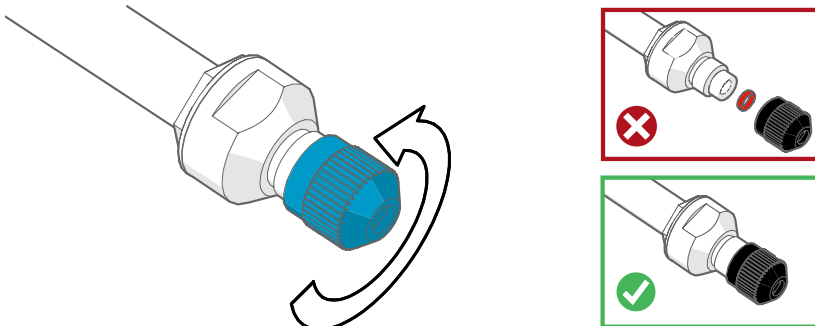

Figure 16 Duct installation overview

- 1 Make sure there is a minimum clearance of 5 m (16.5 ft) between the probe head and any possible humidifier. Avoid installing in a location where condensation can fall on the probe head inside the duct.
- 2 Maximum air flow speed: 50 m/s.
- 3 Avoid installing the probe in dead legs. Supersaturation can occur in areas where there is no air flow.
- 4 Install the probe head in a 90° angle to prevent condensation from travelling to the sensor along the mounting pipe. Position the sensor as close to the middle of the duct as possible.

4.9.3 Mounting HMP9 probe head with Duct Installation Kit

- ▶ 1. Loosen the sealing gland on the back of the pipe by turning it 1.5 full rotations. Do not detach the gland to avoid dislocating the sealing ring.



2. Push the probe head of HMP9 firmly through the sealing gland. Push the probe head further using its cable until it appears from the end of the tube. Adjust so that half of the metal probe head is visible, and tighten the sealing gland by hand so that it holds the probe cable in place.

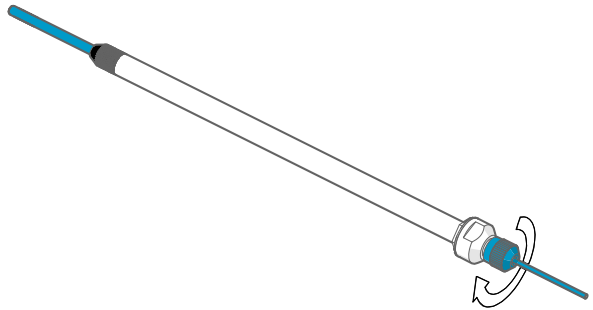
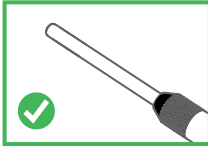
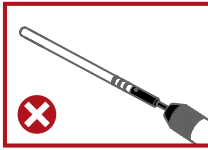

3. Insert the mounting flange on the pipe. Make sure the black sealing surface faces the probe head.
4. Make a $\varnothing 14$ mm (0.55 in) hole in the duct or chamber wall.
5. Push the probe head and pipe into the duct or chamber, and attach the flange using the 2 screws. If necessary, use a drill to make starter holes for the screws (max . $\varnothing 2$ mm (0.07 in)).
6. Adjust the mounting depth of the probe so that the probe is in the middle of the duct, and tighten the holding screw on the flange to lock the pipe in place.

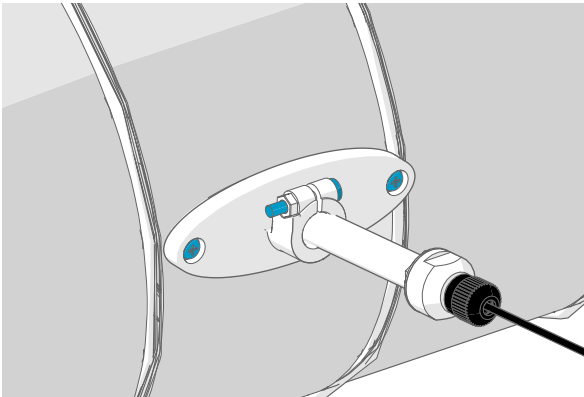

4.10 MMP8 probe

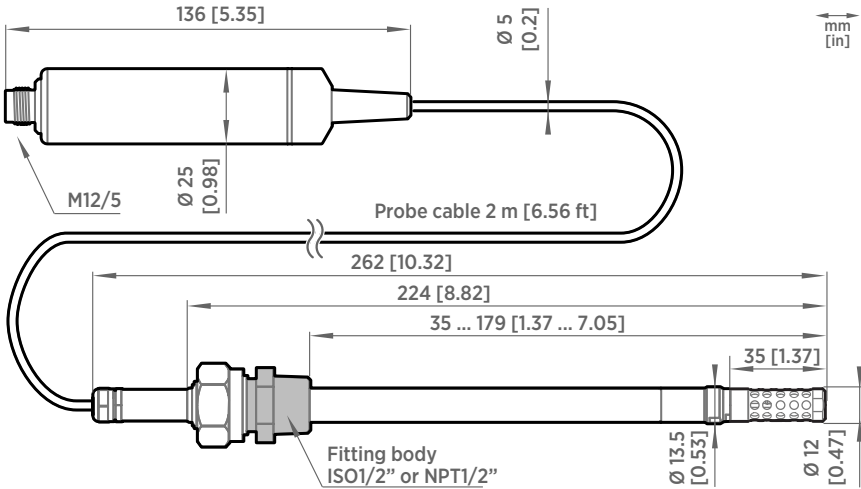

Figure 17 MMP8 dimensions

Vaisala HUMICAP® Moisture in Oil Probe MMP8 enables fast and reliable measurement of moisture in oil. It uses proven Vaisala HUMICAP® sensor that was developed for demanding dissolved moisture measurements in transformer and lubrication oils, hydraulic fluids, and other liquids.

MMP8 measures dissolved moisture in oil in terms of the water activity (a_w), relative saturation (%RS), and temperature (T). Water activity or relative saturation indicate directly whether there is a risk of free water formation. This data is relevant in lubrication oil applications where detecting water ingress and preventing free water formation is crucial. The measurement is independent of oil type and age.

MMP8 can also output ppm, the average mass concentration of water in oil. Vaisala has this conversion readily available for specific oils, including mineral transformer oil. This allows continuous measurement of ppm concentration in power transformer condition monitoring.

- Temperature measurement range $-40 \dots +180 \text{ }^\circ\text{C}$ ($-40 \dots +356 \text{ }^\circ\text{F}$)

When installed with the ball valve kit, the MMP8 is ideal for installation into processes where the probe needs to be installed or removed while the process is running. Probe installation depth is adjustable. Pressure fitting options are ISO 1/2" and NPT 1/2". MMP8 is delivered with a manual pressing handle that allows the probe to be pushed against process pressure.

For installation instructions of the ball valve see [Attaching ball valve kit to process \(page 30\)](#).

4.11 TMP1 probe

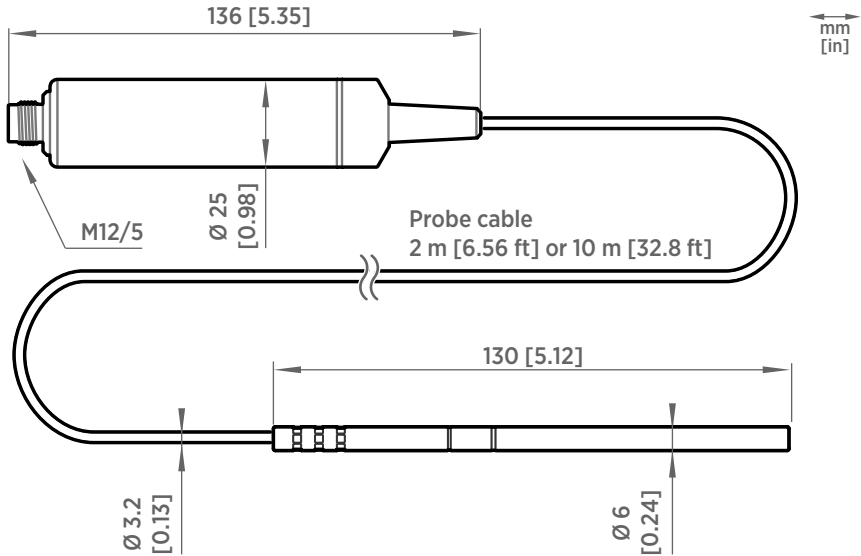

Figure 18 TMP1 probe dimensions

Vaisala Temperature Probe TMP1 is designed for demanding temperature measurements in industrial applications such as pharmaceutical industry and calibration laboratories, where accuracy and robustness are essential.

- Temperature measurement range $-70 \dots +180 \text{ }^\circ\text{C}$ ($-94 \dots +356 \text{ }^\circ\text{F}$)
- Operating temperature of probe body $-40 \dots +80 \text{ }^\circ\text{C}$ ($-40 \dots +176 \text{ }^\circ\text{F}$)

4.12 DTR502B solar radiation shield

DTR502B protects the sensors on the probe head from solar radiation and precipitation in outdoor installations. It provides excellent ventilation while blocking both direct and reflected solar radiation. The special plastic used in the plates has excellent thermal characteristics, the white outer surface reflects radiation, the black inside absorbs accumulated heat. The shield can be easily installed on either a vertical pole, horizontal beam, or a flat surface.

DTR502B is compatible with the probe heads of HMP3, HMP7 and HMP9 probes. HMP9 requires the use of a special sensor head support (item code 215130) due to the smaller diameter of its probe head.



DTR502B is designed to hold only the **probe head**. The probe body must be separately mounted and protected in outdoor installations. If possible, mount the probe indoors and bring only the probe head outside, into the DTR502B.

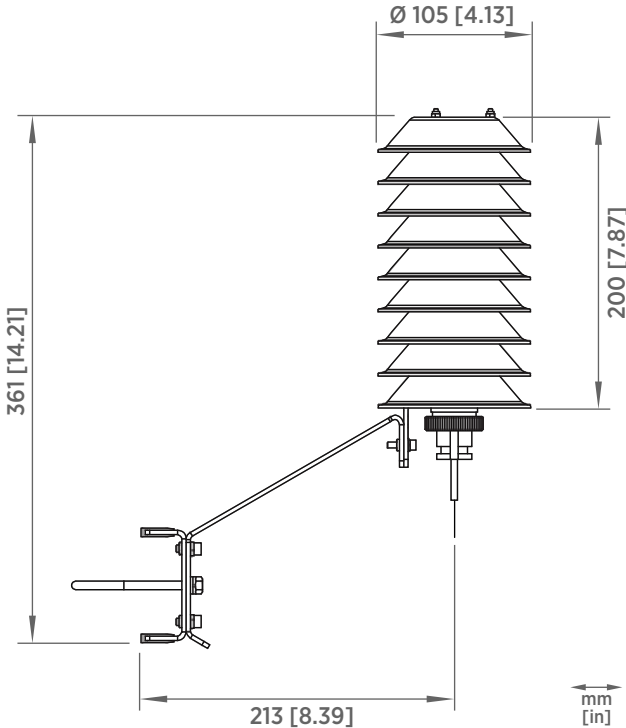

Figure 19 DTR502B dimensions

4.12.1 Mounting probe head inside DTR502B



- 3-mm and 5-mm Allen keys
- Crosshead screwdriver

DTR502B solar radiation shield is compatible with the probe heads of HMP3, HMP7, and HMP9 probes. The sensor head support that is included with the DTR502B is suitable for attaching HMP3 and HMP7 probe heads, but for HMP9 you need an alternate sensor head support (item code 215130).

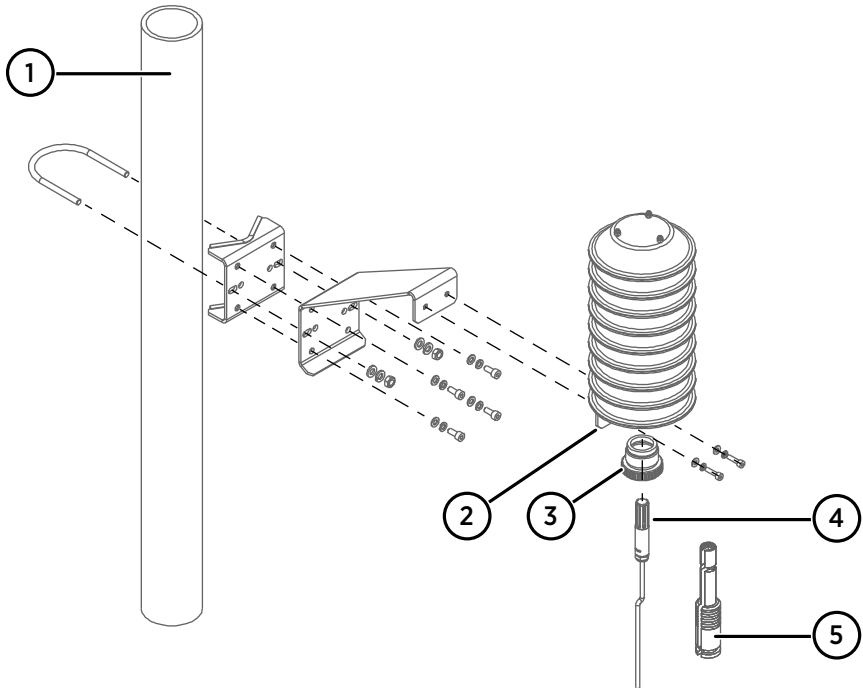

Figure 20 Mounting DTR502B on a pole mast

- 1 Pole mast with diameter 30 ... 60 mm (1.2 ... 2.3 in)
- 2 Support plate
- 3 Fastening ring
- 4 Probe head
- 5 Sensor head support

- ▶ 1. Mount the solar radiation shield in the measurement location using the provided mounting accessories, screws, and washers. You can mount the radiation shield to a pole mast as shown in [Figure 20 \(page 39\)](#), or to a horizontal beam directly from its support plate.

2. Attach the probe head to the sensor head support and secure it with a cable tie. The alternate sensor head support (item code 215130) needed with HMP9 is shown in [Figure 21](#) (page 40).

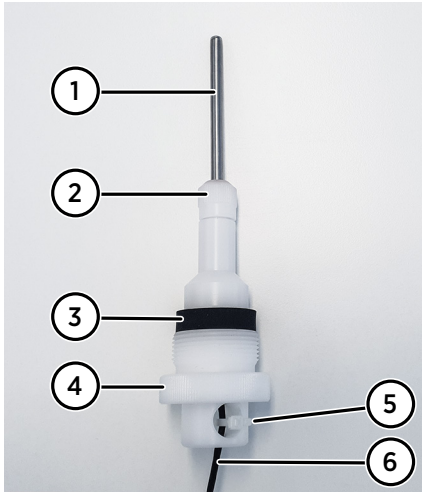

Figure 21 HMP9 probe head with sensor head support 215130

- 1 HMP9 probe head
 - 2 Mounting nut
 - 3 Sealing ring
 - 4 Fastening ring
 - 5 Cable tie
 - 6 Cable between probe head and probe body
3. Insert the fastening ring and the sealing ring on the probe head.
 4. Slide the probe head into the radiation shield and tighten the sealing ring.

5. Configuration with Insight software

5.1 Vaisala Insight software

Vaisala Insight software is a configuration software for Indigo-compatible devices. With the Insight software, you can:

- See probe information and status
- See real-time measurement
- Record data up to 48 hours and export in CSV format
- Calibrate and adjust the probe
- Configure probe features such as measurement filtering, chemical purge, condensation prevention, and serial communication

Microsoft Windows® operating system and Indigo USB adapter (item code USB2) or Vaisala USB cable (item code 242659) required.

Download Vaisala Insight software at www.vaisala.com/insight.

5.2 Connecting to Insight software



- Computer with Microsoft Windows® operating system and Vaisala Insight software installed
- Indigo USB adapter (item code USB2) or USB connection cable (item code 242659)



CAUTION! When connecting several devices at the same time, note that your computer may not be able to supply enough power through its USB ports. Use an externally powered USB hub that can supply >2 W for each port.

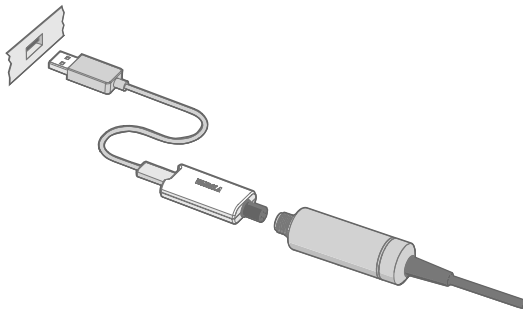

Figure 22 Connecting probe to Insight using Indigo USB adapter

- ▶ 1. Open Insight software.
- 2. Verify the current operating mode of Insight from the **Settings** menu and change it if appropriate:
 - **Basic Mode** is suitable for most use cases.
 - **Advanced Mode** provides access to additional configuration options. Use **Advanced Mode** only when instructed to do so by product documentation or Vaisala technical support.
- 3. Connect the USB adapter to a free USB port on the PC or USB hub.
- 4. Connect the probe to the USB adapter.
- 5. Wait for Insight software to detect the probe.

5.3 Configuration options

Insight software is the recommended way to change the probe configuration. After connecting the probe, select **⚙ > Configure Device** to access the configuration options.

Available configuration options include all of the Modbus configuration registers (see [Configuration registers \(page 104\)](#)) and several additional options. If Insight has been set to **Advanced Mode**, additional configuration options may be available. Use **Advanced Mode** only when instructed to do so by product documentation or Vaisala technical support.

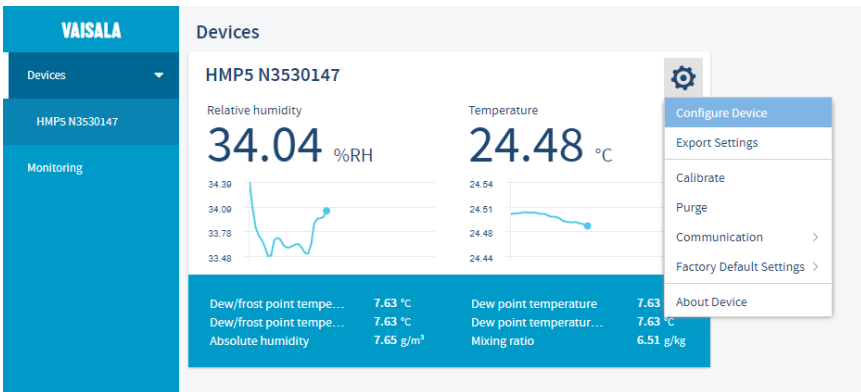

Figure 23 HMP5 in Insight software

5.4 Configuring condensation prevention

- ▶ 1. Connect the probe to Insight. See [Connecting to Insight software \(page 41\)](#).
- 2. Select **⚙ > Configure Device**.

3. Set the **Condensation prevention on/off** switch to the desired setting.



The switch is not available if the probe does not support any condensation prevention heating features, or if the probe firmware version is older than 1.2.0. Probes with older firmware versions will show configuration switches for individual condensation prevention features as applicable.

More information

- [Condensation prevention functions \(page 18\)](#)

5.5 Diagnostics in Insight

Messages sent by the connected devices are shown automatically in Insight. Additional diagnostic data is available on the **Diagnostics** page. The data available depends on the probe model and Insight operating mode (basic or advanced). The data can be very useful when diagnosing issues together with Vaisala support, particularly the diagnostic files.

Diagnostic files

If Insight is in **Advanced Mode**, you can retrieve the following diagnostic files from the connected probe:

- **SSR/T histogram**: Table of humidity and temperature conditions measured by the probe
- **Error log**: Cumulative total of the error and status events tracked by the probe

Both files contain data from since the probe was manufactured, or since the files were last cleared. Clearing the files is not recommended unless instructed by Vaisala support. The buttons to clear the files are located at the bottom of the **Diagnostics** page.

The files are in comma separated value (CSV) format. They can be opened for viewing in spreadsheet programs such as Microsoft Excel or in text editors.

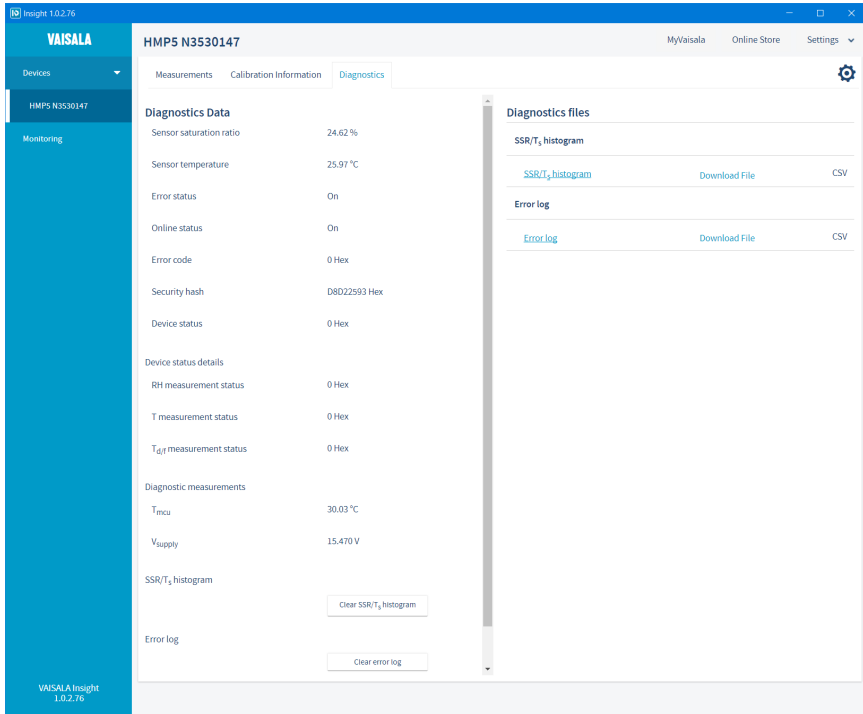

Figure 24 HMP5 diagnostics in Insight (advanced mode)

6. Using probe with Indigo transmitters

Indigo transmitters are host devices that extend the feature set of connected probes with a range of additional options for outputs, configuration access, measurement viewing, and status monitoring.

Available features vary depending on the transmitter model. Models without display use a LED indicator for notifications.

6.1 Indigo200 series transmitters

Indigo200 series transmitters have a probe connector where compatible probes can be attached directly. A cable may also be used to connect the probe.

After connecting the probe, use the wireless configuration interface to configure the transmitter.

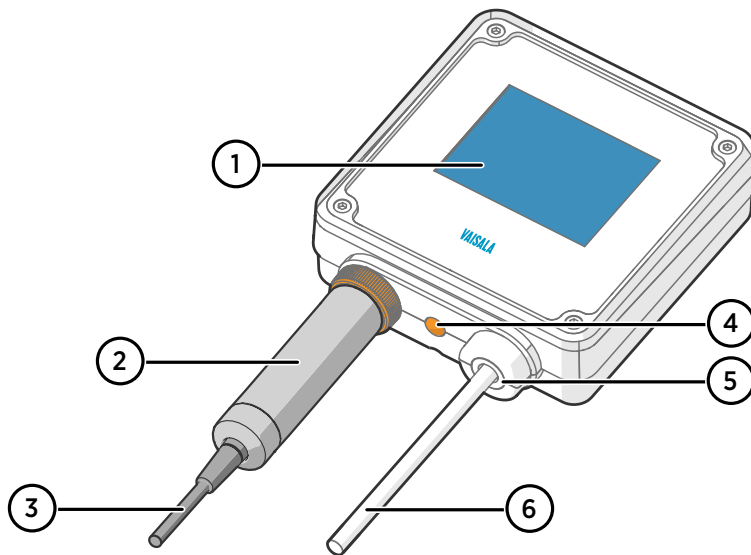

Figure 25 Probe attached to Indigo200 series transmitter directly

- 1 3.5" TFT LCD color display: non-display option with LED available for certain models
- 2 Locking wheel: insert probe, hold in place, and turn the wheel counterclockwise
- 3 Cable to probe head
- 4 Wireless configuration interface (WLAN) activation button
- 5 Rubber lead-through with strain relief. Cable feedthrough option also at back of transmitter.
- 6 Input/output cable

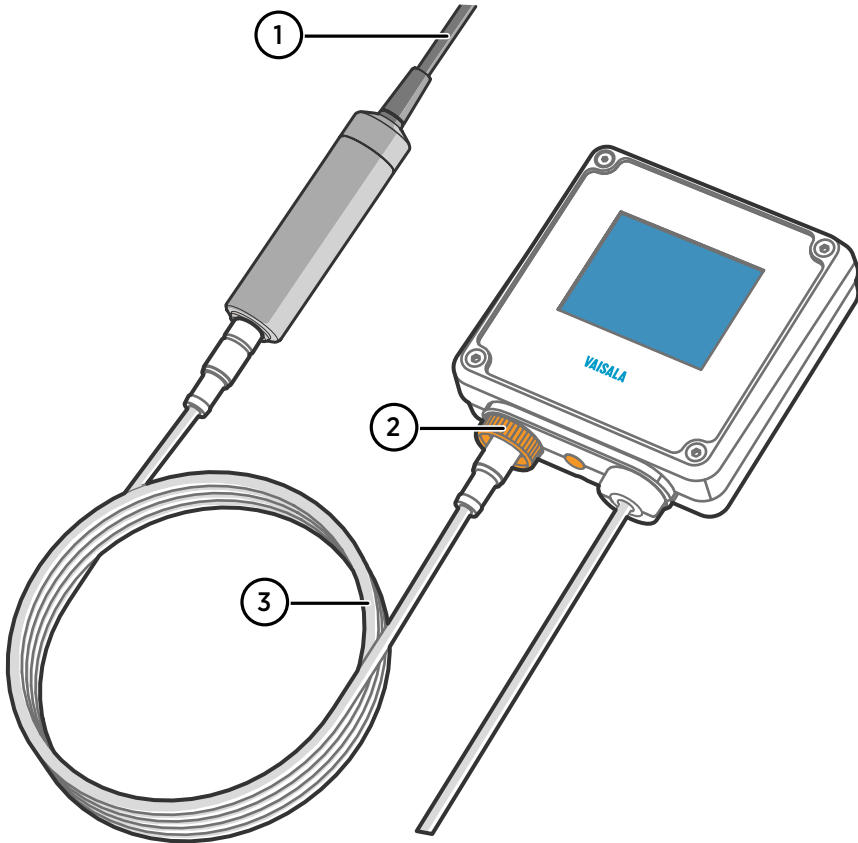

Figure 26 Probe attached to Indigo200 series transmitter with a cable

- 1 Cable to probe head
- 2 Locking wheel: insert cable, hold in place, and turn the wheel counterclockwise
- 3 Connection cable

6.1.1 Attaching probe to Indigo200 series transmitter

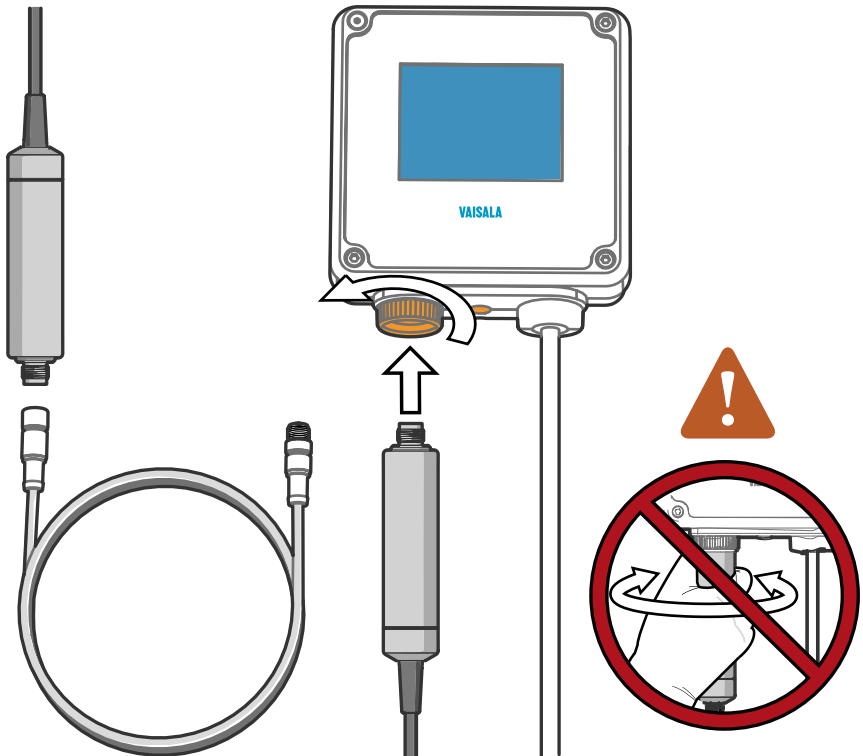

Figure 27 Attaching the probe to Indigo200 series transmitter

- ▶ 1. Insert the probe or the connection cable into the transmitter's connector. Use of connection cable is recommended for strain relief.
2. Turn the locking wheel of the transmitter to lock the probe or cable in place.
Do not turn the probe or the cable itself, as that will damage the connectors.
3. If you are using a connection cable, connect the probe to the cable.
4. When the transmitter recognizes the connected probe, it shows a notification message on the display.

6.2 Indigo500 series transmitters

Probes are connected to Indigo500 series transmitters using a cable. Connections are made to the screw terminals inside the housing. Indigo520 model allows 2 probes to be connected. After connecting a probe, use the touchscreen interface or the web user interface to configure the transmitter.

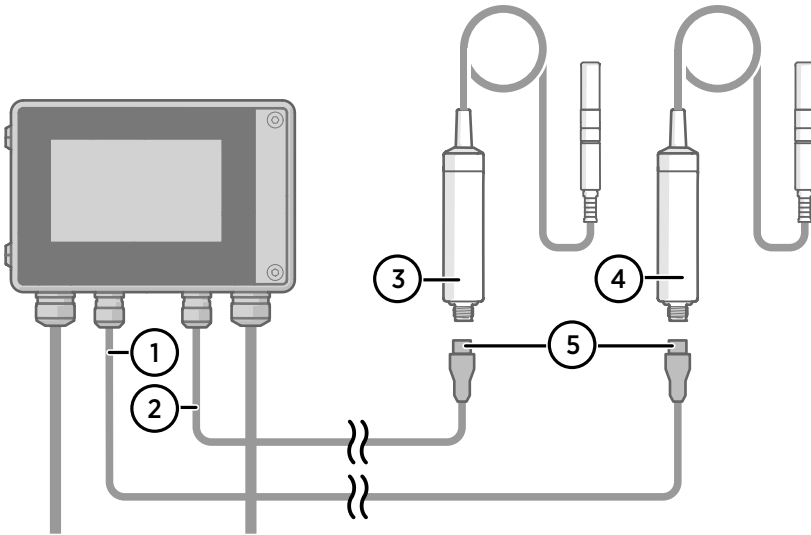



Figure 28 Attaching probes to Indigo500 transmitter

- 1 Probe connection cable, probe 1
- 2 Probe connection cable, probe 2
- 3 Probe to be connected as probe 2
- 4 Probe to be connected as probe 1
- 5 Probe cable connector (5-pin M12)

7. Maintenance

7.1 Cleaning the probe

 **CAUTION!** Do not attempt to clean the sensors under the filter in any way.

 Do not spray anything directly on the probe head, since that may deposit impurities on the sensors.

You can clean the probe, probe body, and cable by wiping them with a soft, lint-free cloth moistened with water or a suitable cleaning agent, such as isopropyl alcohol. Do not wipe the filter: wiping the filter may block its pores and/or deposit residue on the filter. If the filter is heavily contaminated, replace it.

When cleaning, follow these precautions:

- Avoid touching the filter. If you need to touch the filter, always wear clean gloves (cotton, rubber or similar material). Keep the filter free of any grease or oil.
- Do not scrape the probe or the probe body.
- Do not immerse the probe or the probe body in liquid to clean them.
- Wipe cleaning agents off the probe, probe body, and the cable after cleaning.

After cleaning the probe, it is recommended to perform a chemical purge.

7.1.1 Chemical tolerance

 Avoid exposing the probe to cleaning agents for unnecessarily long periods of time.

Table 4 Suitability of cleaning agents

Cleaning Agent	Suitability
Acetone	Suitable
Chlorine disinfectants	Suitable
Ethanol	Suitable
Heptane	Suitable
Isopropyl alcohol	Suitable

7.2 Changing the probe filter



- New compatible filter
- Clean lint-free gloves



CAUTION! Sensors are easily damaged when the filter is not in place. Handle the probe head carefully.



HMP9 and TMP1 probe models do not have a removable filter.

- ▶ 1. Put on clean gloves before touching the filter.
2. Turn the filter counter-clockwise to loosen it.
3. Remove the filter from the probe head. Be careful not to touch the sensors with the filter.
4. Install a new filter on the probe head. Tighten the filter properly (recommended force 5 Nm).

7.3 Replacing the HUMICAP R2 sensor



- New HUMICAP® R2 sensor
- New compatible filter
- Clean lint-free gloves
- 11.3 %RH and 75.5 %RH humidity references (using Vaisala HMK15 Humidity Calibrator)
- Computer with Microsoft Windows® operating system and Vaisala Insight software installed
- Indigo USB adapter (item code USB2) or USB connection cable (item code 242659)

Follow this procedure to replace a HUMICAP® R2 humidity sensor if it has been damaged, or normal adjustment is not sufficient to restore the humidity measurement accuracy. It is recommended that you replace the filter at the same time. The procedure includes a special 2-point adjustment of humidity measurement using Insight PC software. This adjustment must be done every time after the HUMICAP® R2 sensor has been replaced.



CAUTION! Only the HUMICAP® R2 sensor is designed to be replaced by the user. Other humidity sensor types available for HMP series probes are composite sensors where the humidity sensor and temperature sensor are permanently attached together. If you need to replace a composite sensor, contact a Vaisala Service Center.



CAUTION! Sensors are easily damaged when the filter is not in place. Handle the probe head carefully.



CAUTION! Reverting the probe to factory settings clears the adjustment values entered in this procedure. If you need to revert the probe to factory settings after replacing the sensor yourself, write down the values on the **Adjustment data** page beforehand, and enter them again after applying the factory settings.

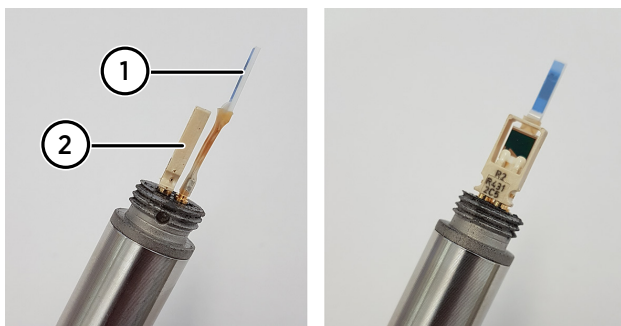

Figure 29 HMP3 probe head with filter removed

- 1 Pt100 temperature sensor
- 2 HUMICAP® R2 humidity sensor

- ▶ 1. Put on clean gloves before touching the filter.
2. Turn the filter counter-clockwise to loosen it.
3. Remove the filter from the probe head. Be careful not to touch the sensors with the filter.
4. There are two sensors under the filter, the HUMICAP® sensor and a temperature sensor. Identify the HUMICAP® sensor and make sure it is of the R2 type (temperature sensor not attached to it).

5. Pull out the old HUMICAP® R2 sensor and insert the new one.



CAUTION! Handle the new sensor by the plastic frame. Do not touch the sensor element in the middle of the sensor. Do not touch the temperature sensor.

6. Open Insight software.
7. Select **Settings > Advanced Mode**.
8. Connect the probe to Insight. See [Connecting to Insight software \(page 41\)](#).
9. Select  **> Calibrate > Yes** to switch the probe to calibration mode.
10. Select **Adjustment data**.
11. Adjust the 11.3 %RH point (dry end):
 - a. Insert the probe head in the 11.3 %RH reference.
 - b. Wait for the measurement to stabilize fully.
 - c. Click table cell A1 under **RH adjustment data** and enter the value of the humidity reference (**11 . 3**).
 - d. Click table cell B1 and enter the %RH measured by the probe.
12. Adjust the 75.5 %RH point (wet end):
 - a. Insert the probe head in the 75.5 %RH reference.
 - b. Wait for the measurement to stabilize fully.
 - c. Click table cell A2 and enter the value of the humidity reference (**75 . 5**).
 - d. Click table cell B2 and enter the %RH measured by the probe.
13. Click outside the table to commit the adjustment.
14. Remove the probe head from the calibration reference and install a new filter. Tighten the filter properly (recommended force 5 Nm).
15. Select the **Calibration information** tab and update the **Calibration date** and **Calibration text**.
16. Select **Close > Yes** to exit the calibration mode.

7.4 Calibration and adjustment

The probe is fully calibrated and adjusted as shipped from the factory. To maintain the accuracy of the measurement, calibrate and adjust the probe as needed. Typical calibration interval is one year, but depending on the application it may be necessary to check the accuracy more frequently.

When adjustment is necessary, you can have Vaisala calibrate and adjust the probe. To order calibration services from Vaisala, visit store.vaisala.com. You can also do the adjustment yourself using the Insight software.



WARNING! When returning a product for calibration or repair, make sure it has not been exposed to dangerous contamination, and is safe to handle without special precautions.



If you think the device is not measuring correctly, calibration and adjustment is not the first thing to do. Check the following first:

- Make sure nothing is interfering with the measurement: heat sources, temperature differences, or condensation.
- Check that there is no moisture on the probe. If the sensor has become wet, wait for it to dry.
- Always wait for the measurement to stabilize.



Calibration means comparing the measurement output of the device to a known reference, such as a known environment in a calibration chamber or the output of a reference instrument. Correcting the reading of the device so that it measures accurately is referred to as **adjustment**.

7.4.1 Adjustment points and requirements

You can adjust the humidity measurement in 1 ... 5 points, and temperature measurement in 1 ... 2 points. Note the following:

- Humidity adjustment in more than two points is available when using Insight software in **Advanced Mode**.
- If you are adjusting in more than one humidity point, make sure the first two points are at least 10 %RH apart.
- The probe will reject adjustments that are too large, that is, greater than 10 %RH for humidity and 0.5 °C for temperature. If the probe appears to need such a large correction, perform a sensor purge and repeat the adjustment procedure. Make sure the measurement has stabilized and the reference environment is reliable. If the required adjustment is still too large, the probe needs to be serviced by Vaisala.



When adjustment of humidity measurement is necessary, Vaisala recommends adjusting in two points, 11 %RH and 75 %RH. These humidities can be produced using the Vaisala HMK15 Humidity Calibrator. Adjustment of temperature measurement is typically not necessary.

7.4.2 HMK15 Humidity Calibrator with HMP Series probes

Vaisala HMK15 Humidity Calibrator is a suitable humidity reference for HMP Series probes. When preparing the salt solutions and using the calibrator, follow the general instructions in the *HMK15 User Guide (M210185EN)* to avoid common sources of calibration error.

HMK15 with HMP3, HMP4, HMP5, HMP7, and HMP8 probes

Before inserting the probe head in the salt jar, remove the filter and inspect the sensor element. If the leg pins of the sensor are longer than 7 mm (0.28 in), attach the 211302SP calibration adapter. This prevents the sensor from being submerged in the salt solution. Composite sensors typically have long leg pins.

211302SP is the longer of the two adapters included with HMK15. With this adapter attached, use the 13.5 mm hole on the salt jar cover.



Figure 30 HMP5 calibration with HMK15 using 211302SP adapter

12 mm (0.47 in) diameter probes where the leg pins are shorter than 7 mm can be inserted in the salt jar without an adapter. Note that you can still use the 218377SP calibration adapter to fit a 12 mm probe in the 13.5 mm hole. This allows you to have multiple probes inserted in a salt jar at one time.



CAUTION! Sensors on the probe head are vulnerable to damage when the filter is removed. Handle the probe carefully and avoid touching the sensors.

HMK15 with HMP1 and HMP9

HMP9 calibration adapter for HMK15 (item code ASM213801) is required to fit the HMP9 probe head to the 12 mm hole on the HMK15 salt jar.



Figure 31 Using HMP9 calibration adapter with HMK15

The same adapter does mechanically fit the HMP1 as well. However, use of HMK15 with HMP1 is not recommended due to additional temperature error caused by heat conduction from the electronics of the probe body. HMP1 should be calibrated so that the entire device is in the calibration environment, not just the probe head. Vaisala's calibration service is a good option for maintaining the accuracy of HMP1.



You can use HMK15 with HMP1 and achieve an accurate calibration if the probe is unpowered during stabilization. This is typically only practical for 1-point calibration.

7.4.3 Adjusting measurement with Insight software



- Computer with Microsoft Windows® operating system and Vaisala Insight software installed
- Indigo USB adapter (item code USB2) or USB connection cable (item code 242659)
- Reference environment(s) for producing the desired humidity and/or temperature

This procedure can be used to adjust the probe's humidity or temperature measurement. If you want to adjust both, repeat the procedure.

Because stabilization of temperature and humidity takes time, you should expect the adjustment procedure to take at least 30 minutes for each adjustment point.

- ▶ 1. Connect the device to Insight. See [Connecting to Insight software \(page 41\)](#).
2. If you intend to adjust humidity measurement, first select  > **Purge** to perform a chemical purge to condition the sensor. Wait a few minutes for purge to complete.

3. Select  > **Calibrate** > **Yes** to switch the probe to calibration mode.
In calibration mode, the device will not use functions that may interfere with calibration and adjustment.
4. Select the type of adjustment to perform: **RH adjustment** or **T adjustment**.
5. Define the needed adjustment for the first measurement point:
 - a. Insert the probe head in the reference environment for the first calibration point.
 - b. Wait for the measurement to stabilize fully.
 - c. Click the **Reference value, point 1** text box and enter the reference value of the calibration point. Press **ENTER** or click outside the text box when done.
 - d. The probe automatically enters the measured values for the calibration point.
6. If you want to adjust in more than one point, repeat [step 5](#) for all desired calibration points.



You can adjust humidity measurement in up to five points when Insight is set to **Advanced mode**.

7. Select **Activate adjustment** > **Yes** to store the adjustment in the probe.
8. Check the message that appears at the top of the screen. If the message indicates that the adjustment is activated successfully, your adjustment is stored in the probe.
9. Select the **Calibration information** tab and update the **Calibration date** and **Calibration text**.
10. Select **Close** > **Yes** to exit the calibration mode.

7.4.4 Adjusting measurement with Indigo200 series transmitter



- Indigo200 series transmitter
- Reference environment(s) for producing the desired humidity and/or temperature (see [Adjustment points and requirements \(page 53\)](#) for more information)
- Mobile device or computer with an internet browser and a Wi-Fi connection
- Connection cable for connecting the probe to Indigo200 series transmitter (optional)

This procedure can be used to adjust the humidity or temperature measurement of an Indigo-compatible HMP or TMP-series probe. Because stabilization of temperature and humidity takes time, you should expect the adjustment procedure to take at least 30 minutes for each adjustment point.



This procedure assumes the Indigo200 transmitter is powered on and the probe is connected to it. Refer to the user guide of your Indigo200 transmitter model for instructions on connecting probes. The user guide also provides more detailed instructions for operating and troubleshooting the wireless connection.

- ▶ 1. Connect to the wireless configuration interface of the Indigo200 transmitter:
 - a. Press the wireless connection activation button on the bottom of the transmitter.
 - b. Open the wireless connection menu in your mobile device or computer and select **Indigo_ID[xx]** (transmitter-specific SSID) from the list of available connections.
 - c. If the wireless configuration interface does not launch automatically on your device, start your browser application manually and navigate to address **192.168.1.1**.
 - d. Log in to the interface:
 - User name: **Admin**
 - Password: **12345** (default)



Stay close to the transmitter for a strong wireless signal and the possibility to read on-screen messages from the transmitter's display (display models only). Starting with Indigo200 firmware version 1.4.0, messages from the probe are also shown through the wireless configuration interface.

2. To adjust humidity measurement:
 - a. If your probe supports the chemical purge feature, wait for the start-up purge to finish or start the purge manually from **Calibration > Configuration > Purge**. Measurement will be frozen for the duration of the purge. Continue when the measured values are changing again.
 - b. Select the **Calibration** tab and select **Start calibration** to start the calibration mode.
 - c. In the **RH adjustment** section of the page, select **Restore factory adjustment** to remove any existing non-factory adjustments.
 - d. Insert the probe head in the reference environment for RH adjustment point 1 (dry point, recommendation 0 ... 35 %RH).
 - e. Wait for the RH and temperature measurements to stabilize fully. This may take more than 30 minutes. Monitor the readings to see when the measurement has stabilized.
 - f. Enter the value of the first reference into the **Reference value, point 1** field. Select outside the text box when done. The probe automatically enters the measured values for the calibration point.
 - g. If you want to adjust humidity measurement in two points, repeat steps [step 2.d](#) ... [step 2.f](#) for RH adjustment point 2 (wet point, recommendation 65 ... 85 %RH).
 - h. Select **Activate adjustment** to store the adjustment in the probe.



When the adjustment is successful, the fields for reference and measured values are cleared. The message **%O adjustment activated successfully**. appears on the local display (display models only). If the adjustment fails, the fields are not cleared. A message on the transmitter's display will indicate the reason. For example, if the humidity adjustment would be over the maximum 10 %RH allowed by the probe, the message **Cumulative adjustment too large**. appears on the local display.

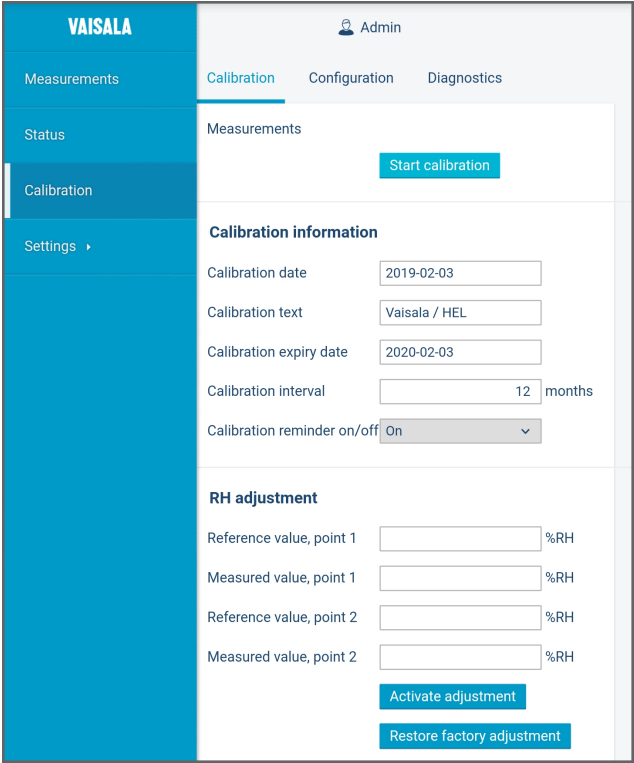

Figure 32 Calibration page in the Indigo200 wireless configuration interface

3. To adjust temperature measurement:
 - a. If you did not adjust humidity measurement, select the **Calibration** tab and select **Start calibration** to start the calibration mode.
 - b. In the **T adjustment** section of the page, select **Restore factory adjustment** to remove any existing non-factory adjustments.
 - c. Insert the probe head in the reference environment for T adjustment point 1.
 - d. Wait for temperature measurement to stabilize fully. This may take more than 30 minutes. Monitor the reading to see when the measurement has stabilized.
 - e. Enter the value of the first reference into the **Reference value, point 1** field. Select outside the text box when done. The probe automatically enters the measured value for the adjustment point.
 - f. If you want to adjust temperature measurement in two points, repeat steps [step 3.c](#) ... [step 3.f](#) for T adjustment point 2.
 - g. Select **Activate adjustment** to store the adjustment in the probe.
4. In the **Calibration information** section of the page, update the **Calibration date** and **Calibration text** fields.
5. Select **Stop calibration** to end the calibration mode.

8. Troubleshooting

8.1 Problem situations

Table 5 Troubleshooting table

Problem	Possible cause	Solution
Measurement output seems incorrect	Installation location is not representative of actual conditions you want to measure	Verify the installation location and relocate the probe if necessary.
	Heat conduction along probe head and cable is interfering with measurement accuracy	Follow the installation recommendations for cases when temperature of measured environment differs greatly from ambient. See Installation (page 20) .
	Probe is in need of adjustment	Calibrate and adjust the probe. See Calibration and adjustment (page 52) .
Probe status indicator LED is red	Probe is in error state	Connect the probe to Insight software or an Indigo transmitter and read the error message(s). See Vaisala Insight software (page 41) and Error messages (page 61) .
Probe status indicator LED is off even though power is on	Probe model is HMPI	To prevent the warming of the indicator LED from causing a slight measurement error, HMPI keeps the indicator normally off (even when power is on). If the probe is in error state, the red LED is shown.
Values of measurement parameters stop changing for a few minutes	Probe is performing a sensor heating function such as chemical purge or waiting for the sensor to cool down	Wait for the function to complete and measurement parameters to be available again

8.2 Error messages

Probes can communicate with error messages when they are connected to an Indigo transmitter or Insight software. The messages are categorized according to the severity of the status:

- **Critical errors** are fatal to the operation of the device. It may not be able to respond to communication at all, and will not measure correctly.
- **Errors** prevent normal operation of the device. Depending on the problem, errors may resolve themselves. For example, a completely wet humidity sensor may cause a humidity measurement error.
- **Warnings** do not prevent normal operation but may indicate possible problems.
- **Status** indicates a known state of the device.

Error message	Description	Recommended action
Critical errors		
Firmware checksum mismatch	Firmware is corrupted	Contact Vaisala technical support
Factory default settings corrupted	Parameter memory is corrupted	
Main configuration settings corrupted		
Additional configuration settings corrupted		
Device settings corrupted		
Sensor coefficients corrupted		
Non-volatile memory read write failure	Hardware fault	
Errors		
Temperature measurement error	Readings from sensors missing or out of range	Inspect probe head and sensors visually. If the probe is completely wet, allow it to dry out. If the sensors are damaged or missing and the error message(s) stay active, contact Vaisala to have the probe repaired.
Humidity measurement error		
Humidity sensor failure		
Capacitance reference error	Hardware fault	Contact Vaisala technical support
Ambient temperature out of range	Probe body too hot or cold	Relocate the probe body so that its ambient temperature is within the specified operating range
Supply voltage out of range	Supply voltage too high or low	Check supply voltage
Sensor heater error	Hardware fault	Contact Vaisala technical support

Warnings		
Calibration certificate checksum mismatch	Certificate stored in the probe has an invalid checksum	Contact Vaisala technical support
Calibration has expired	Shown by calibration reminder functionality	Calibrate the probe and update the calibration date information
Supply voltage too low for probe heating	Probe heating enabled but supply voltage is too low to use it	This warning is expected when probe heating is enabled and the probe is connected to Insight software using an USB cable. The operating voltage provided by the cable is not sufficient for probe heating. If probe is not connected using a Vaisala USB cable, check the supply voltage.
Software restart	Device has automatically restarted itself	Check that supply voltage is stable and operating environment is within specification
Unexpected device restart		
Status messages		
Calibration is about to expire	Shown by calibration reminder functionality	Calibrate the probe and update the calibration date information
Purge in progress	Chemical purge of the humidity sensor ongoing	Wait for chemical purge to complete
The readings stay frozen until the sensor cools down	Probe is waiting for its sensors to cool down	Wait for measurement readings to become available

8.3 Restoring factory default settings

You can restore the probe back to its factory default settings using Insight software. Doing this will also clear any user adjustment and restore the latest adjustment performed by Vaisala.

- ▶ 1. Connect the probe to Insight. See [Connecting to Insight software \(page 41\)](#).
2. Select  > **Factory default settings > Restore settings**.
3. Wait for the probe to be re-detected.

9. Technical data

9.1 HMP1 specifications

Table 6 HMP1 measurement performance

Property	Description/Value
Relative humidity	
Measurement range	0 ... 100 %RH
Accuracy at +23 °C (+73.4 °F) ^{1) 2)}	±1.0 %RH (0 ... 90 %RH)
Factory calibration uncertainty ³⁾	±0.7 %RH (0 ... 40 %RH) ±1 %RH (40 ... 95 %RH)
Non-linearity	0.4 %RH
Sensor	HUMICAP® I
Temperature	
Measurement range	-40 ... +60 °C (-40 ... +140 °F)
Accuracy at +23 °C (+73.4 °F) ^{1) 2)}	±0.2 °C (±0.36 °F)
Factory calibration uncertainty ³⁾	±0.1 °C (±0.18 °F) at +23 °C (+73.4 °F)

- 1) Defined against calibration reference. Including non-linearity, hysteresis, and repeatability.
- 2) In typical room conditions.
- 3) Defined as ±2 standard deviation limits. Small variations possible; see calibration certificate.

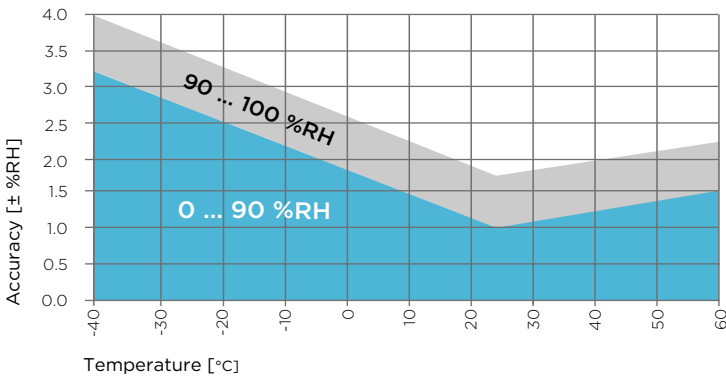

Figure 33 HMP1 humidity measurement accuracy as a function of temperature

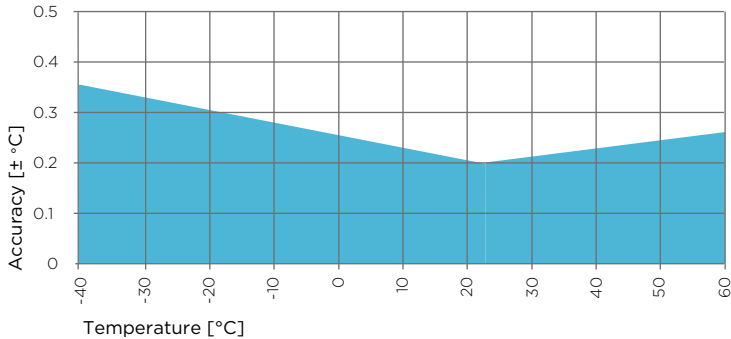

Figure 34 HMP1 temperature measurement accuracy over full range

Table 7 HMP1 operating environment

Property	Description/Value
Operating temperature	-40 ... +60 °C (-40 ... +140 °F)
Storage temperature	-40 ... +60 °C (-40 ... +140 °F)
Measurement environment	For air, nitrogen, hydrogen, argon, helium, and oxygen ¹⁾
IP rating	IP50: Limited protection against dust

1) Consult Vaisala if other chemicals are present. Consider safety regulations with flammable gases.

Table 8 HMP1 inputs and outputs

Property	Description/Value
Operating voltage	15 ... 30 V DC
Current consumption	2 mA typical, 200 mA max.
Digital output	RS-485, non-isolated
Protocol	Modbus RTU

Table 9 HMP1 output parameters

Output parameter name and unit	
Absolute humidity (g/m ³)	Relative humidity (%RH)
Absolute humidity at NTP (g/m ³)	Relative humidity (dew/frost) (%RH)
Dew point temperature (°C)	Temperature (°C)

Output parameter name and unit	
Dew/frost point temperature (°C)	Water concentration (ppm _v)
Dew/frost point temperature at 1 atm (°C)	Water concentration (wet basis) (vol-%)
Dew point temperature at 1 atm (°C)	Water mass fraction (ppm _w)
Dew point temperature difference (°C)	Water vapor pressure (hPa)
Enthalpy (kJ/kg)	Water vapor saturation pressure (hPa)
Mixing ratio (g/kg)	Wet-bulb temperature (°C)

Table 10 HMP1 compliance

Property	Value/Description
EU directives	EMC Directive (2014/30/EU) RoHS Directive (2011/65/EU)
EMC compatibility	EN 61326-1, industrial environment
Compliance marks	CE, China RoHS, RCM, WEEE

Table 11 HMP1 mechanical specifications

Property	Description/Value
Connector	M12 5-pin A-coded male
Weight	38 g (1.34 oz)
Materials	
Probe	AISI 316L
Probe body	PBT

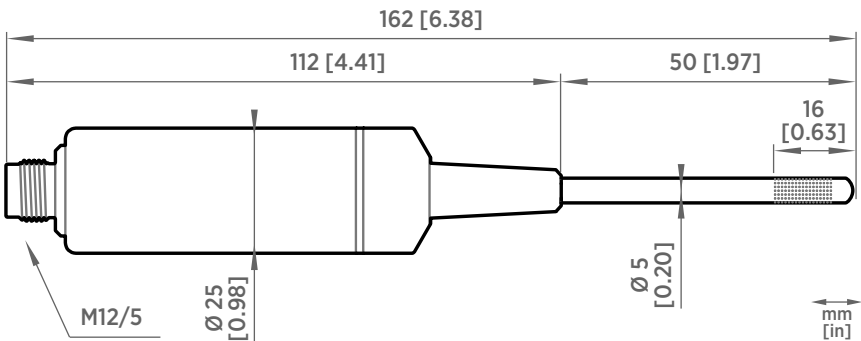

Figure 35 HMP1 probe dimensions

9.2 HMP3 specifications

Table 12 HMP3 measurement performance

Property	Description/Value
Relative humidity	
Measurement range	0 ... 100 %RH
Accuracy at +23 °C (+73.4 °F) ¹⁾	±0.8 %RH (0 ... 90 %RH)
Factory calibration uncertainty ²⁾	±0.5 %RH (0 ... 40 %RH) ±0.8 %RH (40 ... 95 %RH)
T ₆₃ response time	15 s
Sensor options	HUMICAP® R2 HUMICAP® R2C ³⁾ HUMICAP® 180VC ^{3) 4)}
Temperature	
Sensor	Pt100 RTD Class F0.1 IEC 60751
Measurement range	-40 ... +120 °C (-40 ... +248 °F)
Accuracy ^{1) 5)}	±0.1 °C (±0.18 °F)
Factory calibration uncertainty ²⁾	±0.1 °C (±0.18 °F) at +23 °C (+73.4 °F)

- 1) Defined against calibration reference. Including non-linearity, hysteresis, and repeatability.
- 2) Defined as ±2 standard deviation limits. Small variations possible; see calibration certificate.
- 3) Chemical purge feature available with this sensor
- 4) H₂O₂ resistant. With HUMICAP® 180VC sensor, accuracy is not specified below -20 °C (-4 °F) operating temperature.
- 5) Exposing temperature sensor to temperatures outside -20 ... +150 °C (-4 ... +302 °F) may cause permanent additional deviation of ±0.1 °C (0.18 °F)

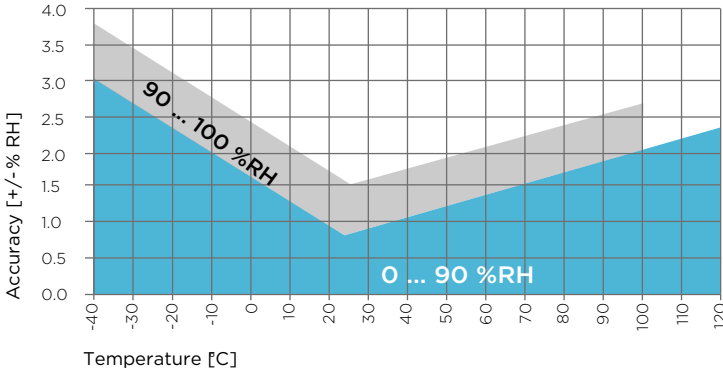

Figure 36 HMP3 humidity measurement accuracy as a function of temperature

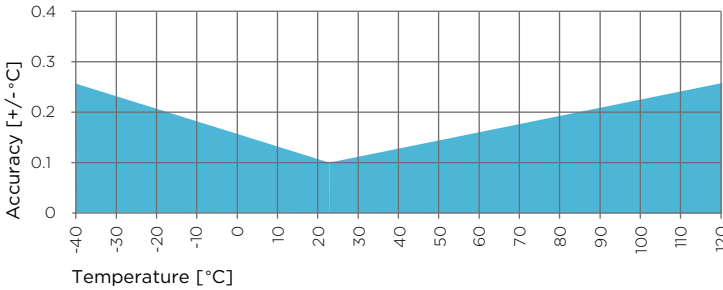

Figure 37 HMP3 temperature measurement accuracy over full range

Table 13 HMP3 operating environment

Property	Description/Value
Operating temperature of probe head	-40 ... +120 °C (-40 ... +248 °F)
Operating temperature of probe body	-40 ... +80 °C (-40 ... +176 °F)
Storage temperature	-40 ... +80 °C (-40 ... +176 °F)
Operating environment	Suitable for outdoor use
Measurement environment	For air, nitrogen, hydrogen, argon, helium, and oxygen ¹⁾
IP rating of probe body	IP66: Dust-tight. Protected from powerful water jets from any direction.

1) Consult Vaisala if other chemicals are present. Consider safety regulations with flammable gases.

Table 14 HMP3 inputs and outputs

Property	Description/Value
Operating voltage	15 ... 30 V DC
Current consumption	10 mA typical, 500 mA max.
Digital output	RS-485, non-isolated
Protocols	Modbus RTU

Table 15 HMP3 output parameters

Output parameter name and unit	
Absolute humidity (g/m ³)	Relative humidity (%RH)
Absolute humidity at NTP (g/m ³)	Relative humidity (dew/frost) (%RH)
Dew point temperature (°C)	Temperature (°C)
Dew/frost point temperature (°C)	Water concentration (ppm _v)
Dew/frost point temperature at 1 atm (°C)	Water concentration (wet basis) (vol-%)
Dew point temperature at 1 atm (°C)	Water mass fraction (ppm _w)
Dew point temperature difference (°C)	Water vapor pressure (hPa)
Enthalpy (kJ/kg)	Water vapor saturation pressure (hPa)
Mixing ratio (g/kg)	Wet-bulb temperature (°C)

Table 16 HMP3 compliance

Property	Value/Description
EU directives	EMC Directive (2014/30/EU) RoHS Directive (2011/65/EU)
EMC compatibility	EN 61326-1, industrial environment
Compliance marks	CE, China RoHS, RCM, WEEE

Table 17 HMP3 mechanical specifications

Property	Description/Value
Connector	M12 5-pin A-coded male
Weight	302 g (10.65 oz)
Materials	
Probe	AISI 316L

Property	Description/Value
Probe body	AISI 316L
Cable jacket	FEP

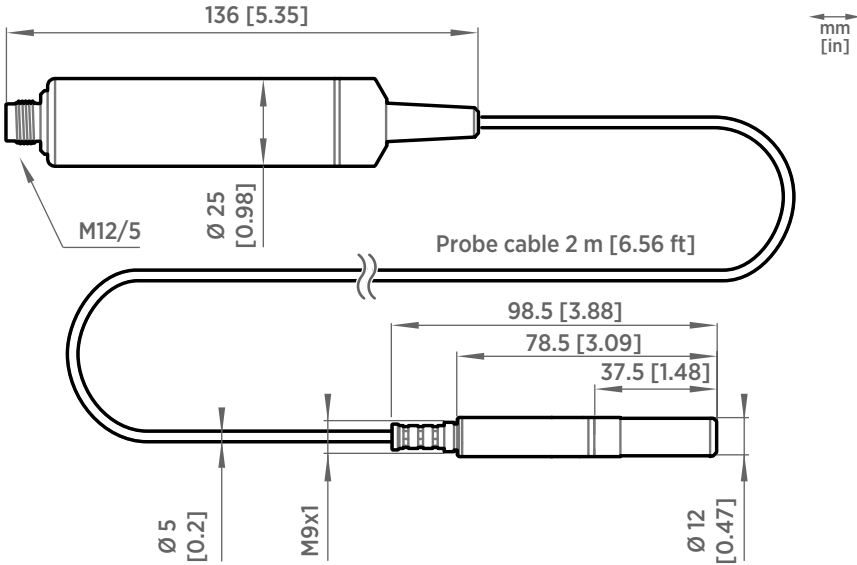

Figure 38 HMP3 probe dimensions

9.3 HMP4 specifications

Table 18 HMP4 measurement performance

Property	Description/Value
Relative humidity	
Measurement range	0 ... 100 %RH
Accuracy at +23 °C (+73.4 °F) ¹⁾	±0.8 %RH (0 ... 90 %RH)
Factory calibration uncertainty ²⁾	±0.5 %RH (0 ... 40 %RH) ±0.8 %RH (40 ... 95 %RH)
T ₆₃ response time	15 s
Sensor options	HUMICAP® R2 HUMICAP® R2C ³⁾

Property	Description/Value
Temperature	
Measurement range	-70 ... +180 °C (-94 ... +356 °F)
Accuracy ^{1) 4)}	±0.1 °C (±0.18 °F)
Factory calibration uncertainty ²⁾	±0.1 °C (±0.18 °F) at +23 °C (+73.4 °F)
Sensor	Pt100 RTD Class F0.1 IEC 60751

- 1) Defined against calibration reference. Including non-linearity, hysteresis, and repeatability.
- 2) Defined as ±2 standard deviation limits. Small variations possible; see calibration certificate.
- 3) Chemical purge feature available with this sensor
- 4) Exposing temperature sensor to temperatures outside -20 ... +150 °C (-4 ... +302 °F) may cause permanent additional deviation of ±0.1 °C (0.18 °F)

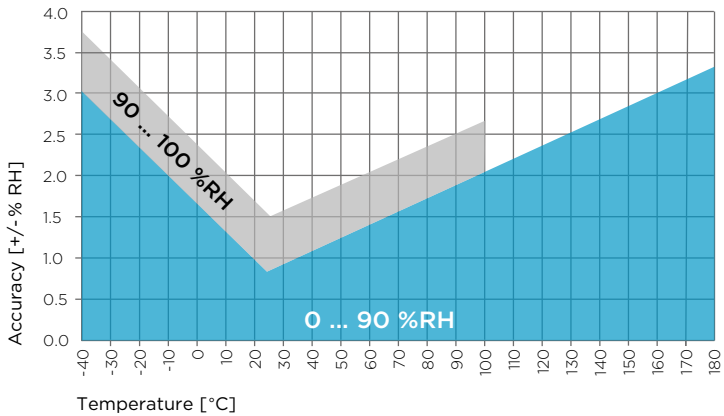

Figure 39 HMP4 humidity measurement accuracy as a function of temperature

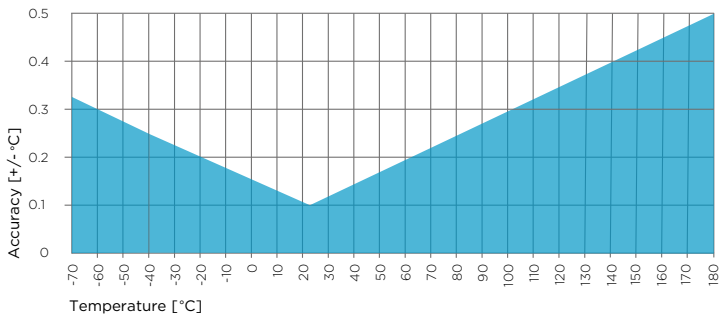

Figure 40 HMP4 temperature measurement accuracy over full range

Table 19 HMP4 operating environment

Property	Description/Value
Operating temperature of probe body	-40 ... +80 °C (-40 ... +176 °F)
Operating temperature of probe head	-70 ... +180 °C (-94 ... +356 °F)
Operational pressure	< 100 bar
Operating environment	Suitable for outdoor use
Measurement environment	For air, nitrogen, hydrogen, argon, helium, oxygen, and vacuum ¹⁾
IP rating of probe body	IP66: Dust-tight. Protected from powerful water jets from any direction.

1) Consult Vaisala if other chemicals are present. Consider safety regulations with flammable gases.

Table 20 HMP4 inputs and outputs

Property	Description/Value
Operating voltage	15 ... 30 V DC
Current consumption	10 mA typical, 500 mA max.
Digital output	RS-485, non-isolated
Protocols	Modbus RTU

Table 21 HMP4 output parameters

Output parameter name and unit	
Absolute humidity (g/m ³)	Relative humidity (%RH)
Absolute humidity at NTP (g/m ³)	Relative humidity (dew/frost) (%RH)
Dew point temperature (°C)	Temperature (°C)
Dew/frost point temperature (°C)	Water concentration (ppm _v)
Dew/frost point temperature at 1 atm (°C)	Water concentration (wet basis) (vol-%)
Dew point temperature at 1 atm (°C)	Water mass fraction (ppm _w)
Dew point temperature difference (°C)	Water vapor pressure (hPa)
Enthalpy (kJ/kg)	Water vapor saturation pressure (hPa)
Mixing ratio (g/kg)	Wet-bulb temperature (°C)

Table 22 HMP4 compliance

Property	Value/Description
EU directives	EMC Directive (2014/30/EU) RoHS Directive (2011/65/EU)
EMC compatibility	EN 61326-1, industrial environment
Compliance marks	CE, China RoHS, RCM, WEEE

Table 23 HMP4 mechanical specifications

Property	Description/Value
Connector	M12 5-pin A-coded male
Fitting body	M22×1.5 or NPT1/2"
Weight	530 g (18.7 oz)
Materials	
Probe	AISI 316
Probe body	AISI 316
Cable jacket	FEP

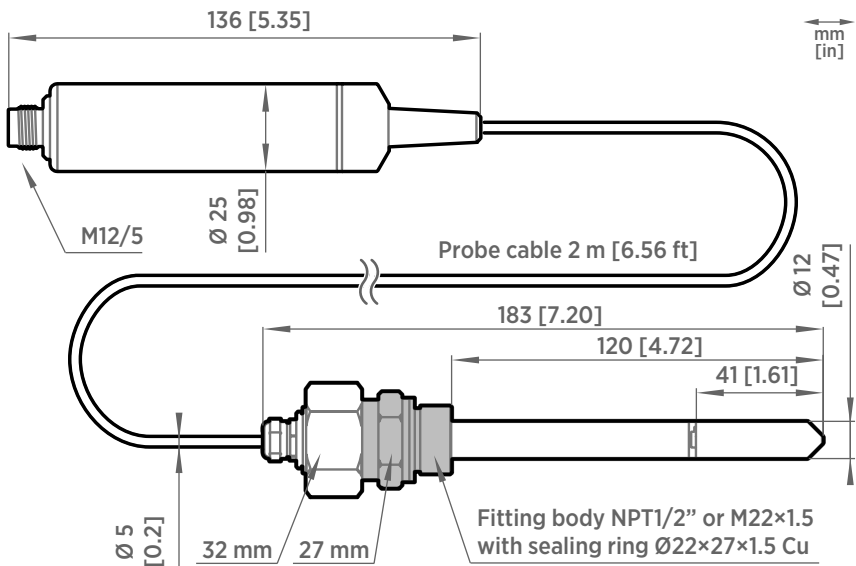

Figure 41 HMP4 probe dimensions

9.4 HMP5 specifications

Table 24 HMP5 measurement performance

Property	Description/Value
Relative humidity	
Measurement range	0 ... 100 %RH
Accuracy at +23 °C (+73.4 °F) ¹⁾	±0.8 %RH (0 ... 90 %RH)
Factory calibration uncertainty ²⁾	±0.5 %RH (0 ... 40 %RH) ±0.8 %RH (40 ... 95 %RH)
T ₆₃ response time	15 s
Sensor options	HUMICAP® R2 HUMICAP® R2C ³⁾
Temperature	
Measurement range	-70 ... +180 °C (-94 ... +356 °F)
Accuracy at +23 °C (+73.4 °F) ^{1) 4)}	±0.1 °C (±0.18 °F)
Factory calibration uncertainty ²⁾	±0.1 °C (±0.18 °F) at +23 °C (+73.4 °F)
Sensor	Pt100 RTD Class F0.1 IEC 60751

- 1) *Defined against calibration reference. Including non-linearity, hysteresis, and repeatability.*
- 2) *Defined as ±2 standard deviation limits. Small variations possible; see calibration certificate.*
- 3) *Chemical purge feature available with this sensor*
- 4) *Exposing temperature sensor to temperatures outside -20 ... +150 °C (-4 ... +302 °F) may cause permanent additional deviation of ±0.1 °C (0.18 °F)*

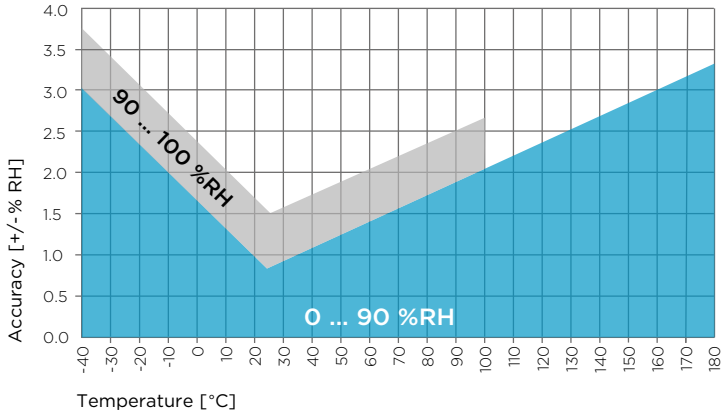

Figure 42 HMP5 humidity measurement accuracy as a function of temperature

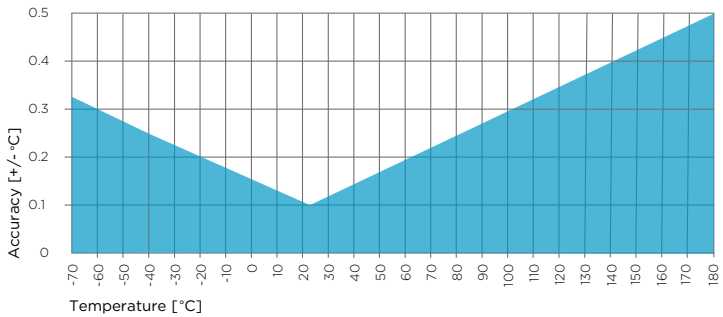

Figure 43 HMP5 temperature measurement accuracy over full range

Table 25 HMP5 operating environment

Property	Description/Value
Operating temperature of probe body	-40 ... +80 °C (-40 ... +176 °F)
Operating temperature of probe head	-70 ... +180 °C (-94 ... +356 °F)
Operating environment	Suitable for outdoor use
IP rating of probe body	IP66: Dust-tight. Protected from powerful water jets from any direction.

Table 26 HMP5 inputs and outputs

Property	Description/Value
Operating voltage	15 ... 30 V DC
Current consumption	10 mA typical, 500 mA max.
Digital output	RS-485, non-isolated
Protocols	Modbus RTU

Table 27 HMP5 output parameters

Output parameter name and unit	
Absolute humidity (g/m ³)	Relative humidity (%RH)
Absolute humidity at NTP (g/m ³)	Relative humidity (dew/frost) (%RH)
Dew point temperature (°C)	Temperature (°C)
Dew/frost point temperature (°C)	Water concentration (ppm _v)
Dew/frost point temperature at 1 atm (°C)	Water concentration (wet basis) (vol-%)
Dew point temperature at 1 atm (°C)	Water mass fraction (ppm _w)
Dew point temperature difference (°C)	Water vapor pressure (hPa)
Enthalpy (kJ/kg)	Water vapor saturation pressure (hPa)
Mixing ratio (g/kg)	Wet-bulb temperature (°C)

Table 28 HMP5 compliance

Property	Value/Description
EU directives	EMC Directive (2014/30/EU) RoHS Directive (2011/65/EU)
EMC compatibility	EN 61326-1, industrial environment
Compliance marks	CE, China RoHS, RCM, WEEE

Table 29 HMP5 mechanical specifications

Property	Description/Value
Connector	M12 5-pin A-coded male
Weight	436 g (15.37 oz)
Materials	
Probe	AISI 316L

Property	Description/Value
Probe body	AISI 316L
Cable jacket	FEP

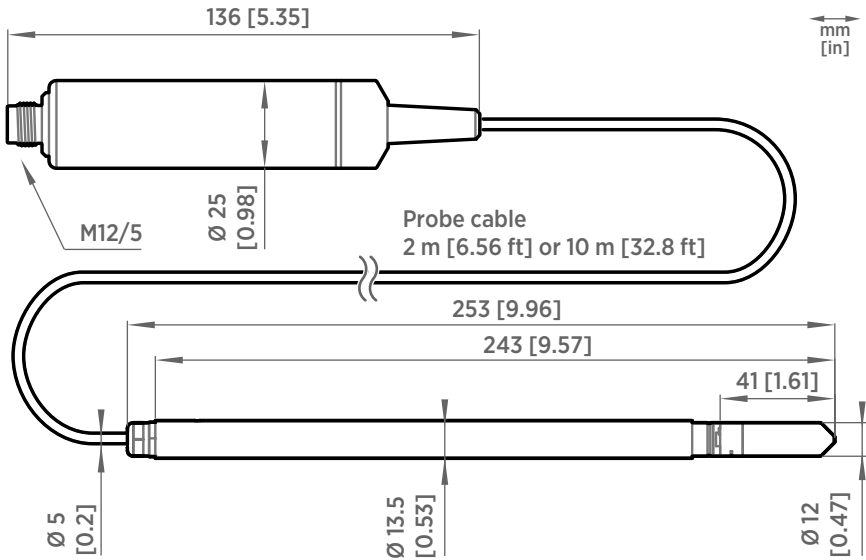

Figure 44 HMP5 probe dimensions

9.5 HMP7 specifications

Table 30 HMP7 measurement performance

Property	Description/Value
Relative humidity	
Measurement range	0 ... 100 %RH
Accuracy at +23 °C (+73.4 °F) ¹⁾	±0.8 %RH (0 ... 90 %RH)
Factory calibration uncertainty ²⁾	±0.5 %RH (0 ... 40 %RH) ±0.8 %RH (40 ... 95 %RH)
T ₆₃ response time	15 s

Property	Description/Value
Sensor options	HUMICAP® R2 HUMICAP® R2C ³⁾ HUMICAP® 180VC ^{3) 4)}
Temperature	
Measurement range	-70 ... +180 °C (-94 ... +356 °F)
Accuracy at +23 °C (+73.4 °F) ^{1) 5)}	±0.1 °C (±0.18 °F)
Factory calibration uncertainty ²⁾	±0.1 °C (±0.18 °F) at +23 °C (+73.4 °F)
Sensor	Pt100 RTD Class F0.1 IEC 60751

- 1) Defined against calibration reference. Including non-linearity, hysteresis, and repeatability.
- 2) Defined as ±2 standard deviation limits. Small variations possible; see calibration certificate.
- 3) Chemical purge feature available with this sensor
- 4) H₂O₂ resistant. With HUMICAP® 180VC sensor, accuracy is not specified below -20 °C (-4 °F) operating temperature.
- 5) Exposing temperature sensor to temperatures outside -20 ... +150 °C (-4 ... +302 °F) may cause permanent additional deviation of ±0.1 °C (0.18 °F)

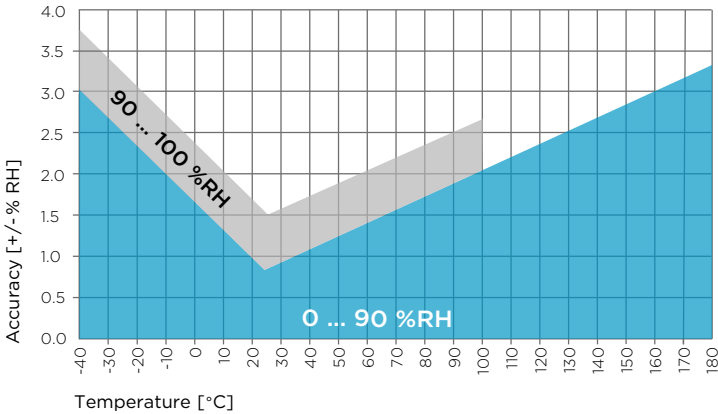

Figure 45 HMP7 humidity measurement accuracy as function of temperature

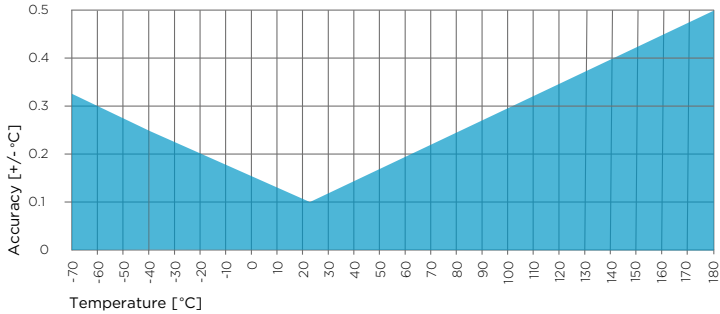

Figure 46 HMP7 temperature measurement accuracy over full range

Table 31 HMP7 operating environment

Property	Description/Value
Operating temperature of probe body	-40 ... +80 °C (-40 ... +176 °F)
Operating temperature of probe head	-70 ... +180 °C (-94 ... +356 °F)
Operational pressure	< 10 bar
Operating environment	Suitable for outdoor use
Measurement environment	For air, nitrogen, hydrogen, argon, helium, oxygen, and vacuum ¹⁾
IP rating of probe body	IP66: Dust-tight. Protected from powerful water jets from any direction.

1) Consult Vaisala if other chemicals are present. Consider safety regulations with flammable gases.

Table 32 HMP7 inputs and outputs

Property	Description/Value
Operating voltage	18 ... 30 V DC
Current consumption	10 mA typical, 500 mA max.
Digital output	RS-485, non-isolated
Protocols	Modbus RTU

Table 33 HMP7 output parameters

Output parameter name and unit	
Absolute humidity (g/m ³)	Relative humidity (%RH)

Output parameter name and unit	
Absolute humidity at NTP (g/m ³)	Relative humidity (dew/frost) (%RH)
Dew point temperature (°C)	Temperature (°C)
Dew/frost point temperature (°C)	Water concentration (ppm _v)
Dew/frost point temperature at 1 atm (°C)	Water concentration (wet basis) (vol-%)
Dew point temperature at 1 atm (°C)	Water mass fraction (ppm _w)
Dew point temperature difference (°C)	Water vapor pressure (hPa)
Enthalpy (kJ/kg)	Water vapor saturation pressure (hPa)
Mixing ratio (g/kg)	Wet-bulb temperature (°C)

Table 34 HMP7 compliance

Property	Value/Description
EU directives	EMC Directive (2014/30/EU) RoHS Directive (2011/65/EU)
EMC compatibility	EN 61326-1, industrial environment
Compliance marks	CE, China RoHS, RCM, WEEE

Table 35 HMP7 mechanical specifications

Property	Description/Value
Connector	M12 5-pin A-coded male
Weight	310 g (10.9 oz)
Materials	
Probe	AISI 316L
Probe body	AISI 316L
Cable jacket	FEP

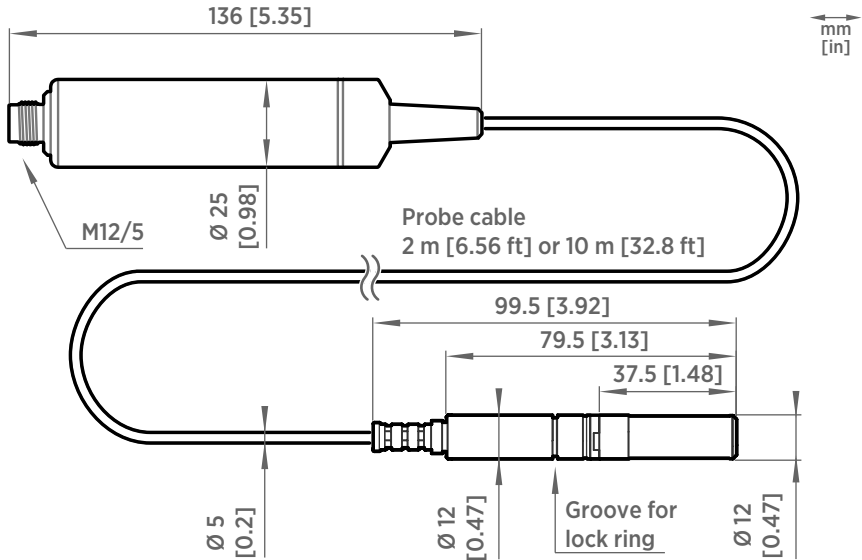

Figure 47 HMP7 probe dimensions

9.6 HMP8 specifications

Table 36 HMP8 measurement performance

Property	Description/Value
Relative humidity	
Measurement range	0 ... 100 %RH
Accuracy at +23 °C (+73.4 °F) ¹⁾	±0.8 %RH (0 ... 90 %RH)
Factory calibration uncertainty ²⁾	±0.5 %RH (0 ... 40 %RH) ±0.8 %RH (40 ... 95 %RH)
T ₆₃ response time	15 s
Sensor options	HUMICAP® R2 HUMICAP® R2C ³⁾
Temperature	
Measurement range	-70 ... +180 °C (-94 ... +356 °F)
Accuracy at +23 °C (+73.4 °F) ^{1) 1) 4)}	±0.1 °C (±0.18 °F)

Property	Description/Value
Factory calibration uncertainty ²⁾	±0.1 °C (±0.18 °F) at +23 °C (+73.4 °F)
Sensor	Pt100 RTD Class F0.1 IEC 60751

- 1) Defined against calibration reference. Including non-linearity, hysteresis, and repeatability.
- 2) Defined as ±2 standard deviation limits. Small variations possible; see calibration certificate.
- 3) Chemical purge feature available with this sensor
- 4) Exposing temperature sensor to temperatures outside -20 ... +150 °C (-4 ... +302 °F) may cause permanent additional deviation of ±0.1 °C (0.18 °F)

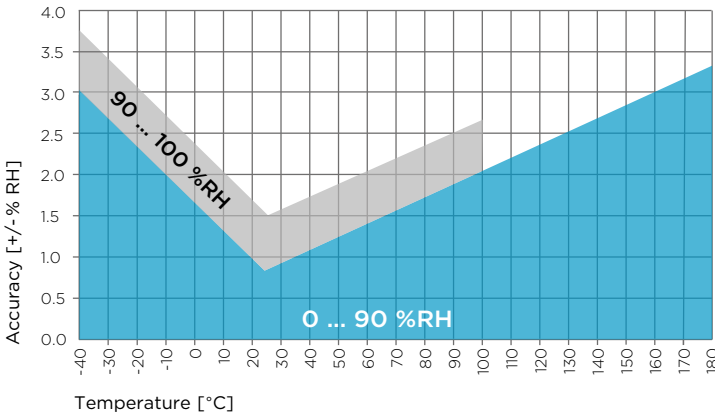

Figure 48 HMP8 humidity measurement accuracy as a function of temperature

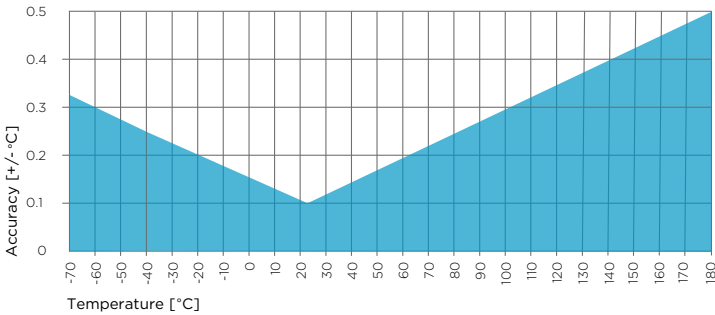

Figure 49 HMP8 temperature measurement accuracy over full range

Table 37 HMP8 operating environment

Property	Description/Value
Operating temperature of probe body	-40 ... +80 °C (-40 ... +176 °F)
Operating temperature of probe head	-70 ... +180 °C (-94 ... +356 °F)
Operational pressure	< 40 bar
Operating environment	Suitable for outdoor use
Measurement environment	For air, nitrogen, hydrogen, argon, helium, oxygen, and vacuum ¹⁾
IP rating of probe body	IP66: Dust-tight. Protected from powerful water jets from any direction.

- 1) Consult Vaisala if other chemicals are present. Consider safety regulations with flammable gases.

Table 38 HMP8 inputs and outputs

Property	Description/Value
Operating voltage	15 ... 30 V DC
Current consumption	10 mA typical, 500 mA max.
Digital output	RS-485, non-isolated
Protocols	Modbus RTU

Table 39 HMP8 output parameters

Output parameter name and unit	
Absolute humidity (g/m ³)	Relative humidity (%RH)
Absolute humidity at NTP (g/m ³)	Relative humidity (dew/frost) (%RH)
Dew point temperature (°C)	Temperature (°C)
Dew/frost point temperature (°C)	Water concentration (ppm _v)
Dew/frost point temperature at 1 atm (°C)	Water concentration (wet basis) (vol-%)
Dew point temperature at 1 atm (°C)	Water mass fraction (ppm _w)
Dew point temperature difference (°C)	Water vapor pressure (hPa)
Enthalpy (kJ/kg)	Water vapor saturation pressure (hPa)
Mixing ratio (g/kg)	Wet-bulb temperature (°C)

Table 40 HMP8 compliance

Property	Value/Description
EU directives	EMC Directive (2014/30/EU) RoHS Directive (2011/65/EU)
EMC compatibility	EN 61326-1, industrial environment
Compliance marks	CE, China RoHS, RCM, WEEE

Table 41 HMP8 mechanical specifications

Property	Description/Value
Connector	M12 5-pin A-coded male
Probe fitting	ISO1/2" and NPT1/2" fittings included
Weight	512 g (18.1 oz)
Materials	
Probe	AISI 316L
Probe body	AISI 316L
Cable jacket	FEP

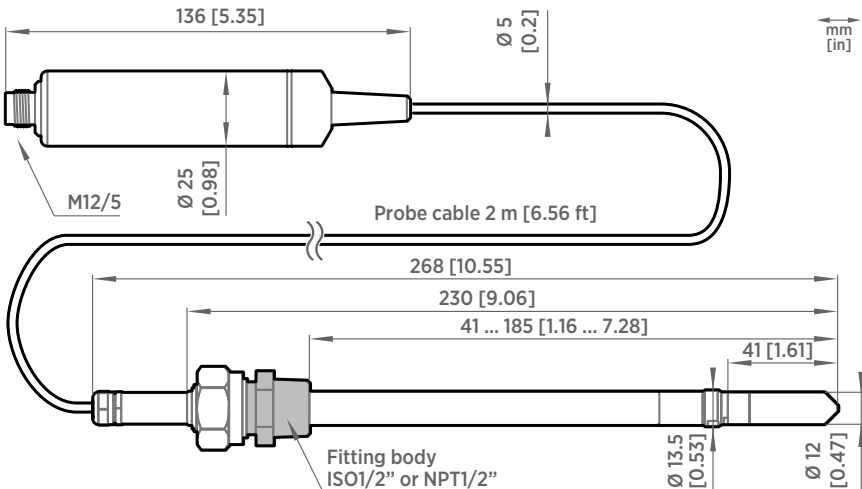

Figure 50 HMP8 probe dimensions

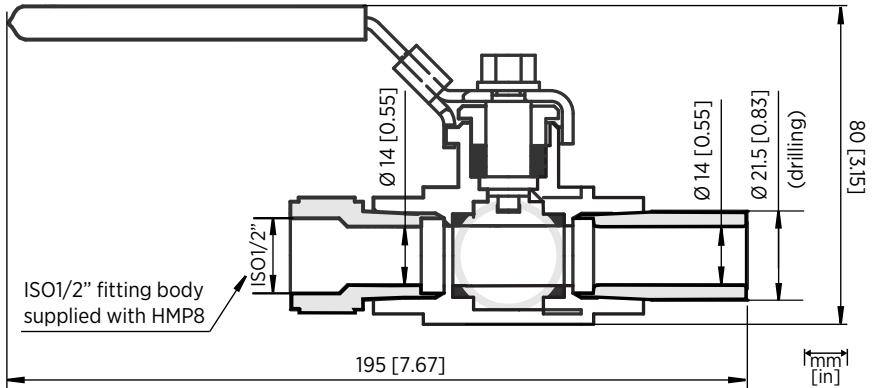

Figure 51 Optional ball valve installation kit dimensions

9.7 HMP9 specifications

Table 42 HMP9 measurement performance

Property	Description/Value
Relative humidity	
Measurement range	0 ... 100 %RH
Accuracy at +23 °C (+73.4 °F) ¹⁾	±0.8 %RH (0 ... 90 %RH)
Factory calibration uncertainty ²⁾	±0.7 %RH (0 ... 40 %RH) ±1 %RH (40 ... 95 %RH)
Non-linearity	0.4 %RH
T ₆₃ response time ³⁾	15 s
Sensor	HUMICAP® I
Temperature	
Measurement range	-40 ... +120 °C (-40 ... +248 °F)
Accuracy at +23 °C (+73.4 °F) ¹⁾	±0.1 °C (±0.18 °F)
Factory calibration uncertainty ²⁾	±0.1 °C (±0.18 °F) at +23 °C (+73.4 °F)
T ₆₃ response time ³⁾	70 s

- 1) Defined against calibration reference. Including non-linearity, hysteresis, and repeatability.
- 2) Defined as ±2 standard deviation limits. Small variations possible; see calibration certificate.
- 3) In still air

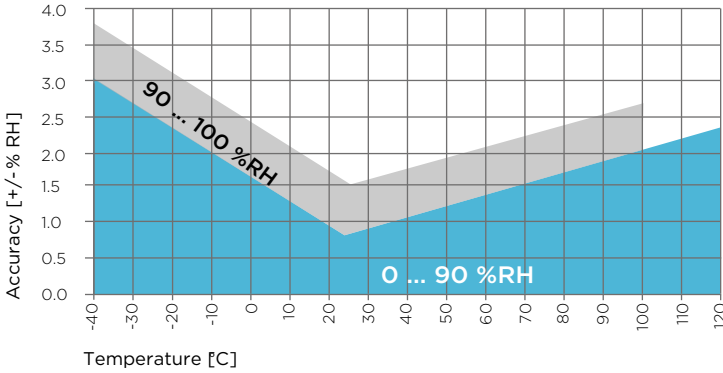

Figure 52 HMP9 humidity measurement accuracy as a function of temperature

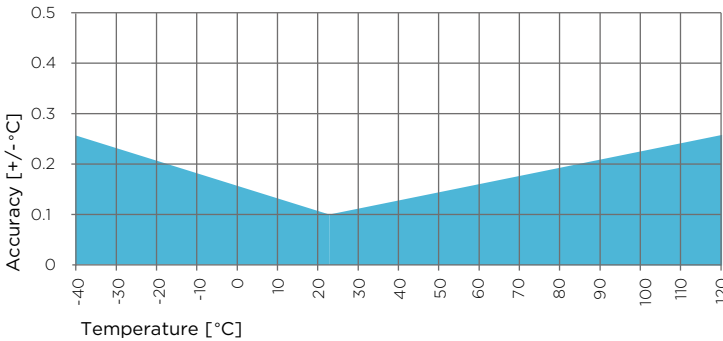

Figure 53 HMP9 temperature measurement accuracy over full range

Table 43 HMP9 operating environment

Property	Description/Value
Operating temperature of probe body	-40 ... +60 °C (-40 ... +140 °F)
Operating temperature of probe head	-40 ... +120 °C (-40 ... +248 °F)
Storage temperature	-40 ... +60 °C (-40 ... +140 °F)
Operating environment	Suitable for outdoor use when protected from rain
Measurement environment	For air, nitrogen, hydrogen, argon, helium, and oxygen ¹⁾

Property	Description/Value
IP rating of probe body	IP65: Dust-tight. Protected from water jets from any direction.

- 1) Consult Vaisala if other chemicals are present. Consider safety regulations with flammable gases.

Table 44 HMP9 inputs and outputs

Property	Description/Value
Operating voltage	15 ... 30 V DC
Current consumption	5 mA typical, 400 mA max.
Digital output	RS-485, non-isolated
Default serial settings	19200 bps N 8 2
Protocol	Modbus RTU

Table 45 HMP9 output parameters

Output parameter name and unit	
Absolute humidity (g/m ³)	Relative humidity (%RH)
Absolute humidity at NTP (g/m ³)	Relative humidity (dew/frost) (%RH)
Dew point temperature (°C)	Temperature (°C)
Dew/frost point temperature (°C)	Water concentration (ppm _v)
Dew/frost point temperature at 1 atm (°C)	Water concentration (wet basis) (vol-%)
Dew point temperature at 1 atm (°C)	Water mass fraction (ppm _w)
Dew point temperature difference (°C)	Water vapor pressure (hPa)
Enthalpy (kJ/kg)	Water vapor saturation pressure (hPa)
Mixing ratio (g/kg)	Wet-bulb temperature (°C)

Table 46 HMP9 compliance

Property	Value/Description
EU directives	EMC Directive (2014/30/EU) RoHS Directive (2011/65/EU)
EMC compatibility	EN 61326-1, industrial environment
Compliance marks	CE, China RoHS, RCM, WEEE

Table 47 HMP9 mechanical specifications

Property	Description/Value
Connector	M12 5-pin A-coded male
Weight	68 g (2.40 oz)
Probe cable length	2 m (6.6 ft)
Materials	
Probe	AISI 316L
Probe body	PBT
Cable overmolds	FEP

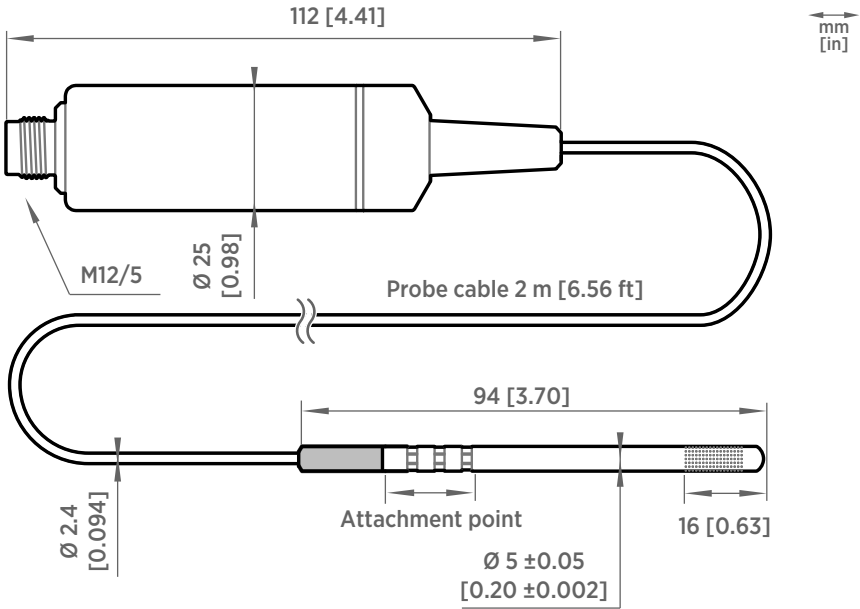

Figure 54 HMP9 probe dimensions

9.8 MMP8 specifications

Table 48 MMP8 measurement performance

Property	Description/Value
Water activity	
Measurement range	0 ... 1 a _w
T ₉₀ response time ¹⁾	10 min
Sensor	HUMICAP® 180L2
Accuracy ²⁾	±0.01 a _w (±1 %RS)
Temperature	
Measurement range	-40 ... +180 °C (-40 ... +356 °F)
Accuracy at +20 °C (+68 °F)	±0.2 °C (0.36 °F)

1) At +20 °C (+68 °F) in still oil.

2) In range 0 ... 0.5 a_w including non-linearity, hysteresis, and repeatability. See accuracy graph below.

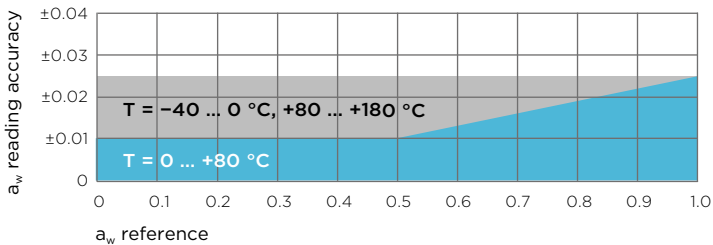

Figure 55 MMP8 A_w measurement accuracy

Table 49 MMP8 operating environment

Property	Description/Value
Operating temperature of probe head	-40 ... +180 °C (-40 ... +356 °F)
Operating temperature of probe body	-40 ... +80 °C (-40 ... +176 °F)
Storage temperature range	-40 ... +80 °C (-40 ... +176 °F)
Operating pressure range	0 ... 40 bar (0 ... 580 psia)
Installation pressure	Up to 10 bar (145 psia)

Property	Description/Value
IP rating of probe body	IP66: Dust-tight. Protected from powerful water jets from any direction.
Ball valve	
Operating temperature	Up to +120 °C (+248 °F)
Operating pressure	Up to 40 bar (0 ... 580 psia)

Table 50 MMP8 inputs and outputs

Property	Description/Value
Operating voltage	15 ... 30 V DC
Current consumption	10 mA typical
Digital output	RS-485, non-isolated
Protocols	Modbus RTU
Output parameters	Relative saturation (%RS) Temperature (°C) Water activity Water mass fraction (ppm _w)

Table 51 MMP8 compliance

Property	Value/Description
EU directives	EMC Directive (2014/30/EU) RoHS Directive (2011/65/EU)
EMC compatibility	EN 61326-1, industrial environment
Compliance marks	CE, China RoHS, RCM, WEEE

Table 52 MMP8 mechanical specifications

Property	Description/Value
Connector	M12 5-pin A-coded male
Weight	510 g (18.0 oz)
Filter options	Stainless steel grid standard filter Stainless steel grid filter for high flow rates (> 1 m/s)
Probe cable length	2 m (6.56 ft)

Property	Description/Value
Adjustable installation depth	35 ... 179 mm (1.37 ... 7.05 in)
Materials	
Probe	AISI 316L
Probe body	AISI 316L
Cable jacket	FEP

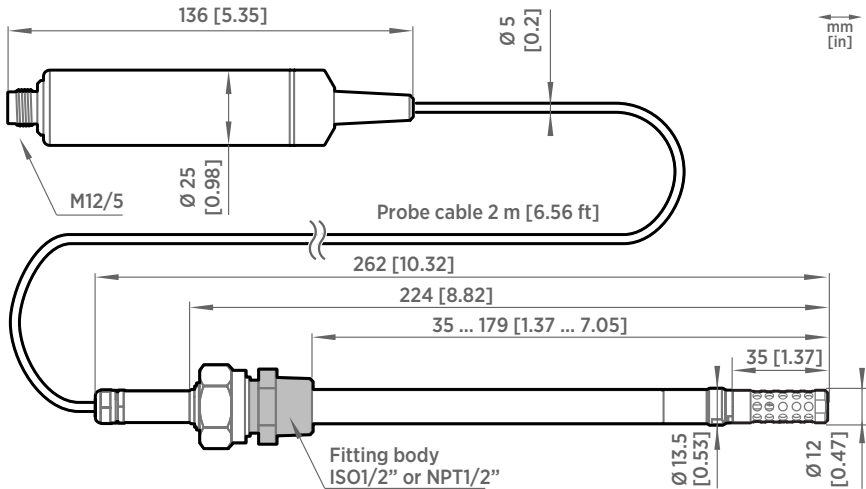

Figure 56 MMP8 dimensions

9.9 TMP1 specifications

Table 53 TMP1 measurement performance

Property	Description/Value
Measurement range	-70 ... +180 °C (-94 ... +356 °F)
Accuracy at +23 °C (+73.4 °F) ^{1) 2)}	±0.1 °C (±0.18 °F)
Factory calibration uncertainty ³⁾	±0.1 °C (±0.18 °F) at +23 °C (+73.4 °F)

Property	Description/Value
Sensor	Pt100 RTD Class F0.1 IEC 60751

- 1) Defined against calibration reference. Including non-linearity, hysteresis, and repeatability.
- 2) Exposing temperature sensor to temperatures outside $-20 \dots +150 \text{ }^\circ\text{C}$ ($-4 \dots +302 \text{ }^\circ\text{F}$) may cause permanent additional deviation of $\pm 0.1 \text{ }^\circ\text{C}$ ($0.18 \text{ }^\circ\text{F}$)
- 3) Defined as ± 2 standard deviation limits. Small variations possible; see calibration certificate.

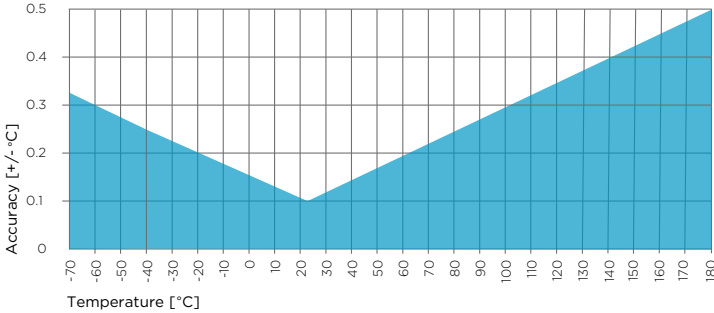

Figure 57 TMP1 temperature measurement accuracy over full range

Table 54 TMP1 operating environment

Property	Description/Value
Operating temperature of probe body	$-40 \dots +80 \text{ }^\circ\text{C}$ ($-40 \dots +176 \text{ }^\circ\text{F}$)
Operating temperature of probe head	$-70 \dots +180 \text{ }^\circ\text{C}$ ($-94 \dots +356 \text{ }^\circ\text{F}$)
Operating environment	Suitable for outdoor use
IP rating	
Probe body	IP66: Dust-tight. Protected from powerful water jets from any direction.
Probe head and cable	IPX8/IPX9: Protected against high pressure and temperature water jets. Protected from the effects of continuous immersion in water. Tested under the following conditions: <ul style="list-style-type: none"> • Immersion depth: 150 cm (59 in) • Immersion time: 60 min

Table 55 TMP1 inputs and outputs

Property	Description/Value
Operating voltage	15 ... 30 V DC

Property	Description/Value
Current consumption	10 mA typical
Digital output	RS-485, non-isolated
Protocols	Modbus RTU
Output parameters	Temperature (°C) Water vapor saturation pressure (hPa)

Table 56 TMP1 compliance

Property	Value/Description
EU directives	EMC Directive (2014/30/EU) RoHS Directive (2011/65/EU)
EMC compatibility	EN 61326-1, industrial environment
Compliance marks	CE, China RoHS, RCM, WEEE

Table 57 TMP1 mechanical specifications

Property	Description/Value
Connector	M12 5-pin A-coded male
Weight	224 g (7.9 oz)
Materials	
Probe	AISI 316L
Probe body	AISI 316L
Cable jacket	FEP

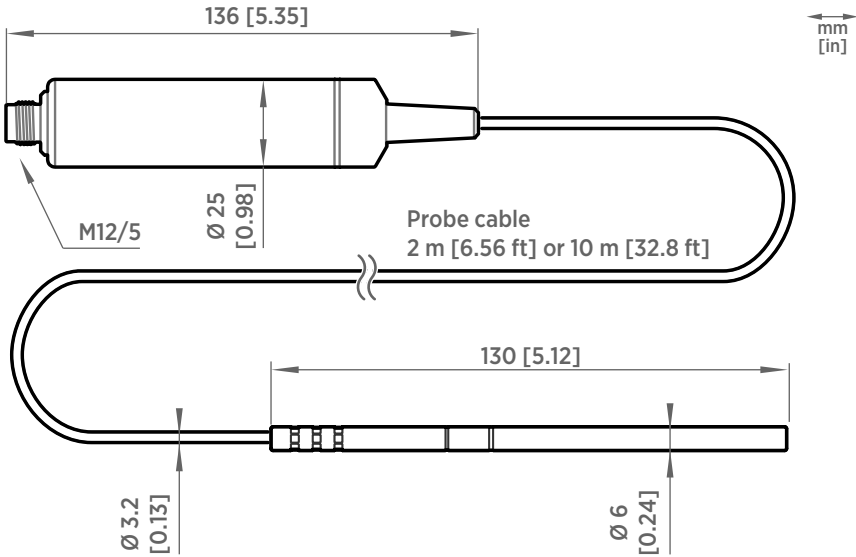

Figure 58 TMP1 probe dimensions

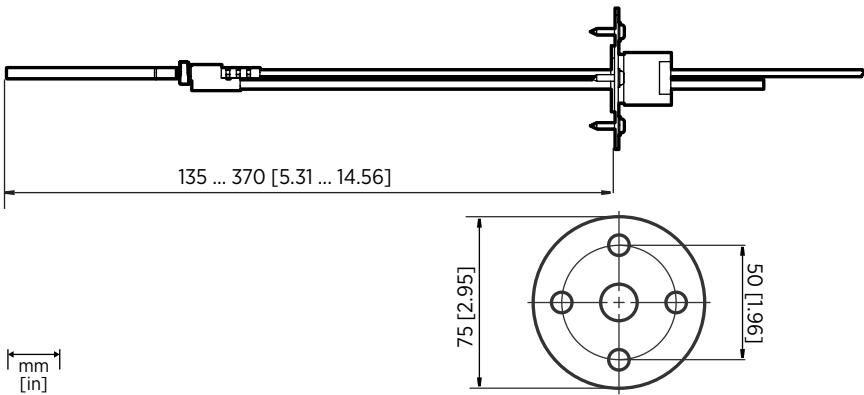

Figure 59 Optional duct kit 215003 dimensions

9.10 Accessories and spare parts



Information on spare parts, accessories, and calibration products is available online at www.vaisala.com and store.vaisala.com.

Connection cables

Table 58 Connection cables

Description	Item code
Connection cable, M12-5F - M12-5M, 1 m	INDIGOCABLE1M
Connection cable, M12-5F - M12-5M, 3 m	INDIGOCABLE3M
Connection cable, M12-5F - M12-5M, 5 m	INDIGOCABLE5M
Connection cable, M12-5F - M12-5M, 10 m	INDIGOCABLE10M
Connection cable, M12-5F - open wires, 1.5 m	223263SP
Connection cable, M12-5F - open wires, 10 m	216546SP
Connection cable, M12-5F 90° - open wires, 0.6 m	244669SP
Flat cable, M12-5F - M12-5M, 1 m	CBL210493SP
Vaisala Indigo USB adapter ¹⁾	USB2

1) Vaisala Insight software for Windows available at www.vaisala.com/insight

HMP3

Table 59 HMP3 accessories

Description	Item code
Duct installation kit	210697
Solar radiation shield DTR502B	DTR502B

Table 60 HMP3 spare parts

Description	Item code
Sensors	
HUMICAP® R2	HUMICAPR2
Filters	
Sintered stainless steel filter	HM47280SP
Stainless steel grid filter	HM47453SP
Metallized PPS plastic grid filter	DRW010276SP
Metallized PPS plastic grid with stainless steel mesh filter	DRW010281SP

HMP4

Table 61 HMP4 spare parts

Description	Item code
Sintered stainless steel filter	HM4728OSP
Stainless steel grid	HM47453SP
Metallized PPS plastic grid with stainless steel mesh filter	DRW010281SP
Metallized PPS plastic grid filter	DRW010276SP

HMP5

Table 62 HMP5 accessories

Description	Item code
Mounting flange	210696

Table 63 HMP5 spare parts

Description	Item code
Sintered stainless steel filter	HM4728OSP
Stainless steel grid	HM47453SP
Metallized PPS plastic grid with stainless steel mesh filter	DRW010281SP
Metallized PPS plastic grid filter	DRW010276SP

HMP7

Table 64 HMP7 accessories

Description	Item code
Duct installation kit for RH probe	210697
Solar radiation shield DTR502B	DTR502B
Cable gland M20×1.5 with split seal	HMP247CG
Swagelok® for 12 mm probe, 1/2" ISO thread	SWG12ISO12
Swagelok® for 12 mm probe, 3/8" ISO thread	SWG12ISO38
Swagelok® for 12 mm probe, 1/2" NPT thread	SWG12NPT12

Table 65 HMP7 spare parts

Description	Item code
Sintered stainless steel filter	HM47280SP
Stainless steel grid	HM47453SP
Metallized PPS plastic grid with stainless steel mesh filter	DRW010281SP
Metallized PPS plastic grid filter	DRW010276SP

HMP8

Table 66 HMP8 accessories

Description	Item code
Ball valve 1/2" with ISO 1/2" welding joint	BALLVALVE-1

Table 67 HMP8 spare parts

Description	Item code
Sintered stainless steel filter	HM47280SP
Stainless steel grid	HM47453SP
Metallized PPS plastic grid with stainless steel mesh filter	DRW010281SP
Metallized PPS plastic grid filter	DRW010276SP

HMP9

Table 68 HMP9 accessories

Description	Item code(s)
HMP9 calibration adapter for HMK15	ASM213801
HMP9 duct installation kit	ASM214055
Solar radiation shield DTR502B with sensor head support 215130	DTR502B and 215130

MMP8

Table 69 MMP8 accessories

Description	Item code
Ball valve ISO 1/2" with welding joint	BALLVALVE-1
Ball valve ISO 1/2" with thread joint ISO 3/4"	BALLVALVE-2

Table 70 MMP8 spare parts

Description	Item code
Stainless steel grid filter	HM47453
Stainless steel grid filter for high flow rates (> 1 m/s)	220752

TMP1

Table 71 TMP1 accessories

Description	Item code
Duct installation kit for T probe	215003
Swagelok® for 6 mm probe 1/8" ISO thread	SWG6ISO18
Swagelok® for 6 mm probe 1/8" NPT thread	SWG6NPT18

Appendix A. Modbus reference

A.1 Default communication settings

Table 72 Default Modbus serial communication settings

Property	Description/Value
Serial bit rate	19200
Parity	None
Number of data bits	8
Number of stop bits	2
Flow control	None
Modbus device address	240

You can use up to ten probes on the same RS-485 line. You must configure each probe on the line to have a different Modbus address.

A.2 Function codes

Table 73 Modbus function codes

Function code (decimal)	Function code (hexadecimal)	Name	Notes
03	03 _{hex}	Read Holding Registers	Class 0
16	10 _{hex}	Write Multiple Registers	Class 0
43 / 14	2B _{hex} / 0E _{hex}	Read Device Identification	

A.3 Data encoding

In the data registers, the numeric values are available in one or two formats with separate register addresses: 32-bit IEEE floating point format and/or 16-bit signed integer format.



For values that have both 32-bit and 16-bit register available, use of the 32-bit register is recommended. Some values may exceed the signed 16-bit range even in normal operation.

A.3.1 32-bit floating point or 32-bit integer format

Registers using **32-bit float** data format are encoded using the **binary32** encoding defined in IEEE 754. The format is also known as "single-precision floating point format".

The least significant 16 bits of a floating point number are placed at the Modbus register listed in the table, while the most significant 16 bits are placed in the register with number/address + 1, as specified in Open Modbus TCP Specification, Release 1.0. This is also known as "little-endian" or "Modicon" word order.

Despite the specification, some Modbus masters may expect a "big-endian" word order (most significant word first). In such case, you must select "word-swapped" floating point format in your Modbus master for the Modbus registers of the device.

A complete 32-bit floating point or 32-bit integer value should be read and written in a single Modbus transaction.



CAUTION! Reading the measurement data registers with incorrect floating point format setting may occasionally result in correct-looking, but nevertheless incorrect values.



It is highly recommended to verify that you have configured the floating point format correctly on your Modbus host system by reading a floating point value from a test value register.

A.3.2 16-bit integer format

Some 16-bit integer values in the data registers are scaled to include the necessary decimals. The scaling factors for those values are shown in the register tables.

Table 74 Interpretation of 16-bit signed integer values

Value (decimal)	Value (hexadecimal)	Description
0 ... 32766	0000 _{hex} ... 7FFE _{hex}	Value in range 0 ... 32766
32767	7FFF _{hex}	Value is 32767 or larger
32768	8000 _{hex}	Value is not available
32769	8001 _{hex}	Value is -32767 or smaller
32770 ... 65535	8002 _{hex} ... FFFF _{hex}	Value in range -32766 ... -1 (2's complement)

A.4 Modbus registers

Registers are numbered in decimal, starting from 1. Register addresses in actual Modbus messages (Modbus Protocol Data Unit (PDU)) are in hexadecimal and start from zero. Register number 1 corresponds to address 0_{hex} in the actual Modbus message.



CAUTION! Reading the wrong register(s) may result in correct-looking values. Check the reference documentation of your Modbus host (PLC) to verify which notation it uses for Modbus register addresses.

A.4.1 Measurement data registers

Table 75 Floating point measurement data registers (read-only)

Register number	Address	Register description	Data format	Unit
1	0000 _{hex}	Relative humidity	32-bit float	%RH
	0001 _{hex}			
3	0002 _{hex}	Temperature	32-bit float	°C
	0003 _{hex}			
7	0006 _{hex}	Dew point temperature	32-bit float	°C
	0007 _{hex}			
9	0008 _{hex}	Dew/frost point temperature	32-bit float	°C
	0009 _{hex}			
11	000A _{hex}	Dew/frost point temperature at 1 atm	32-bit float	°C
	000B _{hex}			
13	000C _{hex}	Dew point temperature at 1 atm	32-bit float	°C
	000D _{hex}			
15	000E _{hex}	Absolute humidity	32-bit float	g/m ³
	000F _{hex}			
17	0010 _{hex}	Mixing ratio	32-bit float	g/kg
	0011 _{hex}			
19	0012 _{hex}	Wet-bulb temperature	32-bit float	°C
	0013 _{hex}			

Register number	Address	Register description	Data format	Unit
21	0014 _{hex}	Water concentration	32-bit float	ppm _v
	0015 _{hex}			
23	0016 _{hex}	Water vapor pressure	32-bit float	hPa
	0017 _{hex}			
25	0018 _{hex}	Water vapor saturation pressure	32-bit float	hPa
	0019 _{hex}			
27	001A _{hex}	Enthalpy	32-bit float	kJ/kg
	001B _{hex}			
29	001C _{hex}	Water activity	32-bit float	
	001D _{hex}			
31	001E _{hex}	Dew point temperature difference	32-bit float	°C
	001F _{hex}			
33	0020 _{hex}	Absolute humidity at NTP	32-bit float	g/m ³
	0021 _{hex}			
35	0022 _{hex}	Water concentration in oil	32-bit float	ppm _v
	0023 _{hex}			
41	0028 _{hex}	Relative saturation	32-bit float	%RS
	0029 _{hex}			
43	002A _{hex}	Water concentration (wet basis)	32-bit float	vol-%
	002B _{hex}			
45	002C _{hex}	Relative humidity (dew/frost)	32-bit float	%RH
	002D _{hex}			
65	0040 _{hex}	Water mass fraction	32-bit float	ppm _w
	0041 _{hex}			

Table 76 Integer measurement data registers (read-only)

Register number	Address	Register description	Data format	Scale factor	Offset	Unit
257	0100 _{hex}	Relative humidity	16-bit signed integer	100	0	%RH
258	0101 _{hex}	Temperature	16-bit signed integer	100	0	°C
260	0103 _{hex}	Dew point temperature	16-bit signed integer	100	0	°C
261	0104 _{hex}	Dew/frost point temperature	16-bit signed integer	100	0	°C
262	0105 _{hex}	Dew/frost point temperature at 1 atm	16-bit signed integer	100	0	°C
263	0106 _{hex}	Dew point temperature at 1 atm	16-bit signed integer	100	0	°C
264	0107 _{hex}	Absolute humidity	16-bit signed integer	100	0	g/m ³
265	0108 _{hex}	Mixing ratio	16-bit signed integer	100	0	g/kg
266	0109 _{hex}	Wet-bulb temperature	16-bit signed integer	100	0	°C
267	010A _{hex}	Water concentration	16-bit signed integer	1	0	ppm _v
268	010B _{hex}	Water vapor pressure	16-bit signed integer	10	0	hPa
269	010C _{hex}	Water vapor saturation pressure	16-bit signed integer	10	0	hPa
270	010D _{hex}	Enthalpy	16-bit signed integer	100	0	kJ/kg
271	010E _{hex}	Water activity	16-bit signed integer	10000	0	-
272	010F _{hex}	Dew point temperature difference	16-bit signed integer	10	0	°C
273	0110 _{hex}	Absolute humidity at NTP	16-bit signed integer	100	0	g/m ³
274	0111 _{hex}	Water concentration in oil	16-bit signed integer	1	0	ppm _v
277	0114 _{hex}	Relative saturation	16-bit signed integer	100	0	%RS

Register number	Address	Register description	Data format	Scale factor	Offset	Unit
278	0115 _{hex}	Water concentration (wet basis)	16-bit signed integer	100	0	vol-%
279	0116 _{hex}	Relative humidity (dew/frost)	16-bit signed integer	100	0	%RH
289	0120 _{hex}	Water vapor mass fraction	16-bit signed integer	1	0	ppm _w

A.4.2 Configuration registers

Table 77 Modbus configuration data registers (writable)

Register number	Address	Register description	Data format	Unit/Valid range
General				
1287	0506 _{hex}	Condensation prevention on/off. Enables the condensation prevention heating functions of the device. When warming is active, values of output parameters that depend on temperature measurement (for example, relative humidity) are unavailable unless temperature is written to register 0334 _{hex} from an external source.	16-bit boolean	0 = off (default) 1 = on
2561	0A00 _{hex}	User information	Text	Text string of 24 bytes in UTF-8 encoding
Compensation setpoints				
769	0300 _{hex}	Pressure compensation setpoint	32-bit float	Unit: hPa Default: 1013.25 hPa
	0301 _{hex}			

Compensation setpoints				
821	0334 _{hex}	Temperature compensation setpoint. If a value is written to this register, probe uses it instead of its own temperature measurement. When condensation prevention warming is active, temperature must be written to this register to enable output parameters that depend on temperature measurement (for example, relative humidity).	32-bit float	Unit: °C
	0335 _{hex}			
Purge				
773	0304 _{hex}	Purge interval	32-bit float	Unit: min 10 ... 14400
	0305 _{hex}			
1283	0502 _{hex}	Interval purge on/off	16-bit boolean	0 = Off 1 = On
1284	0503 _{hex}	Startup purge on/off	16-bit boolean	0 = Off 1 = On
Filtering				
795	031A _{hex}	Measurement filtering factor	32-bit float	Range: 0.000 ... 1.000 1.000 = Reading shows 100% of the most recent measured value (no filtering, default) 0.01 ... 0.99 = Reading shows 1 ... 99% of the most recent measured value and part of the previous reading (filtering is applied). For example, "0.9" means that the filtered measurement reading = 90% of the most recent measured value + 10% of the previous reading.
	031B _{hex}			

Filtering				
1282	0501 _{hex}	Enable or disable measurement filtering using the user-defined filtering factor (register 031A _{hex})	16-bit boolean	0 = Off 1 = On
Communication				
1537	0600 _{hex}	Modbus address	16-bit integer	1 ... 247 Default: 240
1538	0601 _{hex}	Bit rate	enum	0 = 300 1 = 600 2 = 1200 3 = 2400 4 = 4800 5 = 9600 6 = 19200 7 = 38400 8 = 57600 9 = 115200
1539	0602 _{hex}	Parity, data, stop bits	enum	0 = None, 8, 1 1 = None, 8, 2 2 = Even, 8, 1 3 = Even, 8, 2 4 = Odd, 8, 1 5 = Odd, 8, 2 (default: 1 = None, 8, 2)
1540	0603 _{hex}	Response delay	16-bit integer	Unit: ms Range: 0 ... 1000
Functions				
1285	0504 _{hex}	Start purge	16-bit function status	When writing to register: 1 = Start purge
1542	0605 _{hex}	Restart device	16-bit function status	When writing to register: 1 = Restart the device

A.4.3 Status registers

Table 78 Modbus status data registers (read-only)

Register number	Address	Register description	Data format	Note
513	0200 _{hex}	Error status	16-bit boolean	0000_{hex} : One or more errors active 0001_{hex} : No errors
514	0201 _{hex}	Online status	16-bit boolean	0000_{hex} : Output locked 0001_{hex} : Online data available
516	0203 _{hex}	Error code	32-bit signed integer	See Table 79 (page 108) .
	0204 _{hex}			
518	0205 _{hex}	Security hash	32-bit signed integer	Security hash changes when any change is made to device settings or adjustments.
	0206 _{hex}			
520	0207 _{hex}	RH measurement status	16-bit signed integer	0000_{hex} : Status OK 0001_{hex} : Measurement is not available
521	0208 _{hex}	T measurement status	16-bit signed integer	0002_{hex} : Measurement is not reliable
522	0209 _{hex}	T _{d/f} measurement status	16-bit signed integer	0004_{hex} : Under range 0008_{hex} : Over range 0020_{hex} : Value locked 0080_{hex} : Sensor failure 0100_{hex} : Measurement is not ready
523	020A _{hex}	Device status	16-bit signed integer	0000_{hex} : Status OK 0001_{hex} : Critical error, maintenance needed 0002_{hex} : Error, device may recover automatically 0004_{hex} : Warning 0008_{hex} : Notification 0010_{hex} : Calibration mode active

Table 79 Error codes in register 0203_{hex}

Bitmask	Error message	Severity
0000 _{hex}	Status OK	
0001 _{hex}	Temperature measurement error	Error
0002 _{hex}	Humidity measurement error	Error
0004 _{hex}	Humidity sensor failure	Error
0008 _{hex}	Capacitance reference error	Error
0010 _{hex}	Ambient temperature out of range	Error
800000 _{hex}	Sensor heater failure	Warning

A.4.4 Test value registers

Read the known test values from the test registers to verify the functionality of your Modbus implementation.

Table 80 Modbus test registers (read-only)

Register number	Address	Register description	Data format	Test value
7937	1F00 _{hex}	Signed integer test	16-bit integer	-12345
7938	1F01 _{hex}	Floating point test	32-bit float	-123.45
	1F02 _{hex}			
7940	1F03 _{hex}	Text string test	text	Text string "-123.45"
	1F04 _{hex}			
	1F05 _{hex}			
	1F06 _{hex}			

A.5 Device identification objects

Table 81 Device identification objects

Object ID	Object ID (hexadecimal)	Object name	Example contents
0	00 _{hex}	VendorName	"Vaisala"
1	01 _{hex}	ProductCode	"HMP4"

Object ID	Object ID (hexadecimal)	Object name	Example contents
2	02 _{hex}	MajorMinorVersion	"1.2.3" Software version of the device.
3	03 _{hex}	VendorUrl	" http://www.vaisala.com/ "
4	04 _{hex}	ProductName	"Humidity and Temperature Probe HMP4"
5	05 _{hex}	ModelName	"7E2A2A0A000" Configuration code of the device. Length and content of the code are model-specific.
6	06 _{hex}	UserApplicationName	User definable information text (see configuration register 0A00 _{hex})
128	80 _{hex}	SerialNumber ¹⁾	"K0710040"
129	81 _{hex}	CalibrationDate ¹⁾	"2020-01-31" Calibration date in YYYY-MM-DD format. Empty string if not set/valid.
130	82 _{hex}	CalibrationText ¹⁾	"Vaisala/HEL" Calibration information text. Empty string if not set/valid.

1) *Vaisala-specific device information.*

A.6 Exception responses

Table 82 Modbus exception responses

Code	Name	Reason
01	ILLEGAL FUNCTION	Unsupported function code
02	ILLEGAL DATA ADDRESS	Register address or Object ID out of valid ranges
03	ILLEGAL DATA VALUE	Otherwise invalid request

Accessing unavailable (temporarily missing) measurement data does not generate a Modbus exception. "Unavailable" value (a quiet NaN for floating point data or 8000_{hex} for integer data) is returned instead. An exception is generated only for any access outside the applicable register ranges.

A.7 Modbus communication examples

Reading relative humidity value



Device address used in the following examples is 240 (F0_{hex}).
 Measurement values returned by the device change depending on ambient conditions and/or device settings.

Request		Response	
Bytes on the line (hexadecimal)	Description	Bytes on the line (hexadecimal)	Description
(silence for 3.5 bytes)	Start of Modbus RTU frame	(silence for 3.5 bytes)	Start of Modbus RTU frame
F0 _{hex}	Probe address	F0 _{hex}	Probe address
03 _{hex}	Function (Read Holding Registers)	03 _{hex}	Function (Read Holding Registers)
00 _{hex}	Register address	04 _{hex}	Number of data bytes
00 _{hex}		7A _{hex}	Value of first register (least significant word)
00 _{hex}	Number of 16-bit registers to read (2)	E1 _{hex}	
02 _{hex}		41 _{hex}	Value of second register (most significant word)
D1 _{hex}	Modbus RTU checksum	F4 _{hex}	Modbus RTU checksum
2A _{hex}			
(silence for 3.5 bytes)	End of Modbus RTU frame	05 _{hex}	
		(silence for 3.5 bytes)	End of Modbus RTU frame

Communication description	
Register address	1 (1-based Modbus documentation format) = 0000 _{hex} (0-based format used in actual communication).
Data format	Two 16-bit Modbus registers interpreted as IEEE 754 binary32 floating point value, least significant word first.
Returned value	41F47AE1 _{hex} , which is binary32 representation of 30.56 (%RH).

Writing pressure compensation value

Request		Response	
Bytes on the line (hexadecimal)	Description	Bytes on the line (hexadecimal)	Description
(silence for 3.5 bytes)	Start of Modbus RTU frame	(silence for 3.5 bytes)	Start of Modbus RTU frame
F0 _{hex}	Probe address	F0 _{hex}	Probe address
10 _{hex}	Function (Write Multiple Registers)	10 _{hex}	Function (Write Multiple Registers)
03 _{hex}	Register address	03 _{hex}	Register address
00 _{hex}		00 _{hex}	
00 _{hex}	Number of registers to write (2)	00 _{hex}	Number of 16-bit registers written (2)
02 _{hex}		02 _{hex}	
04 _{hex}	Number of data bytes	54 _{hex}	Modbus RTU checksum
6E _{hex}	Value for first register (least significant word)	AD _{hex}	
14 _{hex}			
44 _{hex}	Value for second register (least significant word)	(silence for 3.5 bytes)	End of Modbus RTU frame
75 _{hex}			
4E _{hex}	Modbus RTU checksum	<div style="border: 1px solid gray; padding: 10px; background-color: #f0f0f0;">  <p>The response to a write function informs that the function was correctly received by the device. It does not guarantee that the written value was accepted by the device (for example, in case out-of-range values).</p> <p>To verify that the value was really accepted by the device, read the register value after writing.</p> </div>	
AB _{hex}			
(silence for 3.5 bytes)	End of Modbus RTU frame		

Communication description

Register address	769 (1-based Modbus documentation format) = 0300 _{hex} (0-based format used in actual communication).
------------------	--

Communication description	
Data format	Two 16-bit Modbus registers interpreted as IEEE 754 binary32 floating point value, least significant word first.
Value to write	44756E14 _{hex} = 981.72 (hPa)

Maintenance and calibration services



Vaisala offers comprehensive customer care throughout the life cycle of our measurement instruments and systems. Our factory services are provided worldwide with fast deliveries. For more information, see www.vaisala.com/calibration.

- Vaisala Online Store at store.vaisala.com is available for most countries. You can browse the offering by product model and order the right accessories, spare parts, or maintenance and calibration services.
- To contact your local maintenance and calibration expert, see www.vaisala.com/contactus.

Warranty

For standard warranty terms and conditions, see www.vaisala.com/warranty.

Please observe that any such warranty may not be valid in case of damage due to normal wear and tear, exceptional operating conditions, negligent handling or installation, or unauthorized modifications. Please see the applicable supply contract or Conditions of Sale for details of the warranty for each product.

Technical support



Contact Vaisala technical support at helpdesk@vaisala.com. Provide at least the following supporting information as applicable:

- Product name, model, and serial number
- Software/Firmware version
- Name and location of the installation site
- Name and contact information of a technical person who can provide further information on the problem

For more information, see www.vaisala.com/support.

Recycling



Recycle all applicable material.



Follow the statutory regulations for disposing of the product and packaging.

VAISALA

www.vaisala.com

