

# Installation Guide

Model 227

Ultra High Purity 1 1/8" Down-Mount  
"C" Seal and "W" Seal Pressure Transducer



**setra**<sup>®</sup>

1-800-257-3872 Toll Free

1-978-264-0292 Fax

[www.setra.com](http://www.setra.com) Web Site

# Setra Model 227 Ultra High Purity Transducers

## 1.0 GENERAL INFORMATION

Your Setra Pressure Transducer has been carefully tested and calibrated before shipment. Model 227 performance specifications are listed on Section 2.2 of this guide.

Setra's 227 pressure transducers sense gauge, compound or absolute pressure and convert this pressure to a proportional high level analog output. Two output versions are offered: a voltage output of 5 VDC FSO (Full Scale Output) and 10 VDC FSO, as well as current output of 4 to 20 mA.

**NOTE: Latest version of this document may be found at [www.setra.com](http://www.setra.com).**

## 1.1 EMC CERTIFICATIONS

This products complies with the latest revision of EN61326-1 and EN61326-2-3 Electrical Equipment for Measurement, Control and Laboratory use - EMC Requirements for Minimum Requirements and Industrial Locations. In order to meet EMC compliance the following conditions must be followed:

1. Shielded cable must be used and the shield must be tied to earth ground (not power supply ground) on at least one end of the cable shield/drain wire. The shield must be maintained all the way from the sensor to the power supply.
2. If unshielded cable is used, an earth grounded metal conduit fitting can be used to replace the shielded cable.
3. For a sensor with a metal body or enclosure, the body/enclosure must be grounded to earth. If a protective metal housing is used, the metal housing should be grounded to earth.

## 2.0 MECHANICAL INSTALLATION

### 2.1 MEDIA COMPATIBILITY

Model 227 transducer is designed to be used with any gas or liquid compatible with 316L Stainless Steel. Never submerge the transducer in any liquids.

### 2.2 PERFORMANCE SPECIFICATIONS

<b>ACCURACY*:</b>	$\pm 1.0\%$ Reading	<b>THERMAL EFFECTS:</b>	
(at constant temperature)	$\pm 0.25\%$ FS	Comp Range °F(°C)	+15 to +150 (-9 to +65)
Non-Linearity, BFSL	$\pm 0.15\%$ FS	Zero Shift %FS/100°F(50°C)	2.0 (1.8)
Hysteresis	0.20% FS	Span Shift %FS/100°F(50°C)	2.0 (1.8)
Non-Repeatability	0.02% FS	Warm-Up Shift	< $\pm 0.1\%$ FS Total

\*RSS of Non Linearity, Non repeatability & Hysteresis

### ENVIRONMENTAL DATA:

Operating Temperature °F(°C)	-40 to +185 (-40 to 85)
Storage Temperature °F(°C)	-40 to +185 (-40 to 85)

### Current Unit Ordered with Option N1:

Operating Temperature °F(°C)	-22 to +176 (-30 to 80)
Storage Temperature °F(°C)	-22 to +176 (-30 to 88)

### 2.3 PRESSURE FITTING

Mounting: Model 227 pressure transducers are supplied with 1.125" down-mount "C" or "W" seal base. (Note: The torque values listed are typical for most systems, please adjust the values to fit your system.) The tightening sequence forms a leak tight seal between the base block and the unit. Using 4 screws to install the unit, follow the torque sequence pattern in Diagram A for "C-seal bases. Use a torque driver and torque all 4 screws to 25 in. lbs, repeat sequence and torque all 4 screws to 35 in. lbs, then repeat sequence for 45 in. lbs.

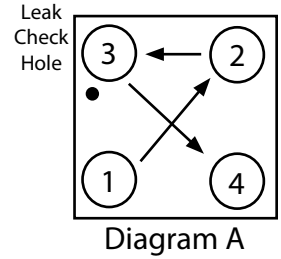

**Do not over tighten. See technical documents from fitting manufacturer for addition instructions.**

### 3.0 ELECTRICAL INSTALLATION

#### 3.1 VOLTAGE OUTPUT UNITS

The Model 227 voltage output transducer is supplied with a multi-conductor cable or various style connectors. See Diagram 1 & 2 for proper connections.

CONNECTION TABLE FOR VOLTAGE OUTPUT TRANSDUCERS

CONNECTION	CABLE WIRE	BAYONET PIN	9 PIN DSUB	15 PIN DSUB
+EXCITATION:	RED	A	4	7
+OUTPUT:	GREEN	B	1	2
-OUTPUT:	WHITE	C	8	12
-EXCITATION:	BLACK	D	9	5
CASE GND:	SHIELDING	SHELL	SHELL	SHELL
EXCITATION: 10-30 VDC for 0.2 to 5.2 VDC and 0 to 5 VDC & 13-30 VDC for 0.2 to 10.2 VDC and 0 to 10 VDC				

DIAGRAM 1

**NOTE: "-EXCITATION" and "-OUTPUT" are connected together internally.**

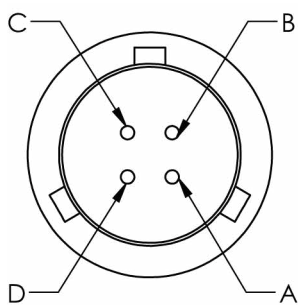

4 PIN BAYONET

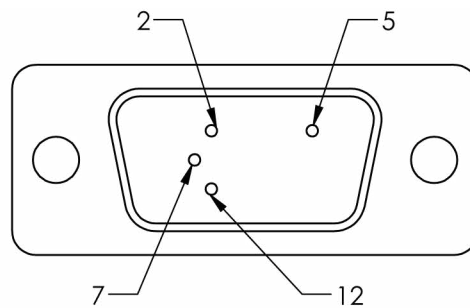

15 PIN HIGH DENSITY DSUB

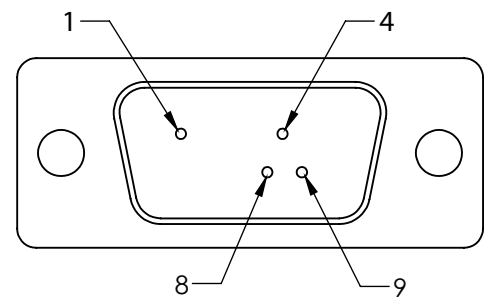

9 PIN DSUB

DIAGRAM 2: TRANSDUCER PIN OUT

### 3.2 CURRENT OUTPUT UNITS



See sections 3.3 and 3.4 for addition instructions for units with N1 Output Codes.

The Model 227 is a two-wire loop-powered 4 to 20 mA current output unit and delivered rated current into an external load of 0-800 ohms. The Model 227 is available with a multi-conductor cable or various style connectors. Diagram 3 shows electrical connection wiring for current output transducers.

**CONNECTION TABLE FOR CURRENT OUTPUT TRANSDUCERS**

	CABLE WIRE	BAYONET	9 PIN DSUB	15 PIN DSUB
CONNECTION	WIRE	PIN	PIN	PIN
+EXCITATION	RED	A	4	7
-EXCITATION	BLACK	D&B	9	5
CASE GND	SHIELDING	SHELL	SHELL	SHELL
MINIMUM SUPPLY VOLTAGE: $10 + 0.02 \times \text{LOOP RESISTANCE}$ MAXIMUM SUPPLY VOLTAGE: $30 + 0.004 \times \text{LOOP RESISTANCE}$				

Diagram 3

The power supply must be a DC voltage source with a voltage range between 10 VDC and 30 VDC measured between the "+EXCITATION" and "-EXCITATION". The unit is calibrated at the factory with a 24 VDC loop supply voltage and a 250 ohm load.

Current must flow in one direction only. Please observe polarity. See Diagram 4.

The cable shield Drain Wire shall be connected to the earth ground to comply with EMC requirements and electrical noise rejection.

**NOTE: The transducer case and integral Bayonet connector shell are electrically connected.**

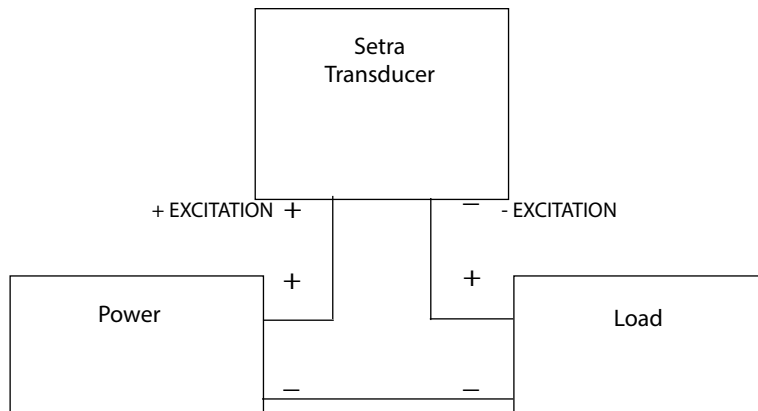

Diagram 4

### 3.3 ETL Listed to ANSI/ISA-12.2.01-2015 Standards

The current output unit may be installed in Class 1 Hazardous (Classified) Group A, B, C, D Division 2 locations, if the unit was ordered N1 designation in the Part Number, 12<sup>th</sup> and 13<sup>th</sup> digits. Safety barriers are not required as long as the unit is operated under normal conditions with a maximum excitation voltage of 30 VDC between the input terminals.



- **WARNING - EXPLOSION HAZARD. DO NOT REMOVE OR REPLACE WHILE THE CIRCUIT IS LIVE UNLESS THE AREA IS FREE OF IGNITABLE CONCENTRATIONS**
- **WARNING- PLEASE DO NOT CONNECT OR DISCONNECT WHILE ENERGIZED**
- **WARNING - CONNECTORS MUST BE EITHER TOOL-SECURED OR INSIDE A TOOL ACCESSED ENCLOSURE**
- **WARNING - THE CABLE AND WIRING METHOD SHALL COMPLY WITH LOCAL ELECTRICAL CODES, E.G, NEC FOR THE US.**

### 3.4 ATEX 2014/34/EU Zone 2 Approval to EN60079-0:2012 and EN60079-15:2010

Setra 227 pressure transmitter with N1 suffix is certified by Setra to operate in ATEX zone 2 areas with Ex marking II 3G Ex nA IIC T4 Gc -30°C<Ta<+80°C. Safety barriers are not required as long as the unit is operated under normal conditions with a maximum excitation voltage of 30 VDC between the input terminals. The following requirements must be met to maintain compliance to listed standards.



- **WARNING - DO NOT SEPARATE WHEN ENERGIZED**
- **WARNING - DO NOT OPEN, MAINTAIN OR SERVICE IN AN AREA WHERE EXPLOSIVE ATMOSPHERE MAY BE PRESENT**
- A minimum degree of IP54 protection shall be maintained in the hazardous location. The zero/span plugs shall be installed securely at all times when the transducer is in service. The mating connector provided by the end user shall be in accordance with all applicable classes of EN60079-0 and EN60079-15.
- Connectors must be securely attached by tool before power is applied
- The shielded cable must be used and the drain wire of the cable must be connected to the earth ground. The transducer body must be connected to earth ground.
- The maximum allowable transient disturbance must not exceed more than 40% of the maximum excitation voltage.
- No adjustment on Zero or Span potentiometer shall be made in the presence, or potential for, hazardous atmosphere.

### 4.0 CALIBRATION

All Setra pressure transducers are carefully calibrated to the specific input pressure range vs. output voltage or current at the factory so little or no field calibrating is necessary. Zero and span adjustments can be made by turning the rotatable cover or disengaging the plugs to expose the zero and span pots. The adjustments pots should be covered after calibration is complete.

#### 4.1 VOLTAGE OUTPUT ZERO ADJUSTMENT

Transducer zero may be adjusted by monitoring the voltage between +OUTPUT and -OUTPUT while turning the zero potentiometer screw. This adjustment should occur with atmospheric pressure applied for gage transducers. Absolute and compound transducers should be adjusted while a full vacuum is applied. Compound transducers may alternatively be adjusted at atmospheric pressure using the values in Diagram 5.

#### NOMINAL "INSTALLED" OUTPUT AT ATMOSPHERIC PRESSURE

PSI COMPOUND RANGE	5 VDC FSO		10 VDC FSO	
	0.2 to 5.2 VDC	0 to 5 VDC	0.2 to 10.2 VDC	0 to 10 VDC
-14.7 to 25	2.051	1.851	3.903	3.703
-14.7 to 50	1.336	1.136	2.472	2.272
-14.7 to 100	0.841	0.641	1.482	1.282
-14.7 to 250	0.478	0.278	0.755	0.555
-14.7 to 500	0.343	0.143	0.486	0.286
-14.7 to 1000	0.272	0.072	0.345	0.145
-14.7 to 3000	0.224	0.024	0.249	0.049

BAR COMPOUND RANGE	5 VDC FSO		10 VDC FSO	
	0.2 to 5.2 VDC	0 to 5 VDC	0.2 to 10.2 VDC	0 to 10 VDC
-1 to 1.7	2.052	1.851	3.904	3.704
-1 to 3.4	1.336	1.136	2.473	2.273
-1 to 7	0.825	0.625	1.450	1.250
-1 to 17	0.478	0.278	0.756	0.556
-1 to 35	0.339	0.139	0.478	0.278
-1 to 70	0.270	0.070	0.341	0.141
-1 to 200	0.225	0.025	0.250	0.050

Diagram 5

#### 4.2 VOLTAGE OUTPUT SPAN ADJUSTMENT

Zero adjustment must be performed prior to span adjustment. Span adjustment should only be performed by use of an appropriate pressure standard (electric manometer, digital pressure gauge, etc) with at least 4X the accuracy of a model 227. The span may be adjusted by turning the span potentiometer while full scale pressure is applied to the pressure port.

### 4.3 CURRENT OUTPUT ZERO ADJUSTMENT

Transducer zero may be adjusted by monitoring the current output while turning the zero potentiometer screw. This adjustment should occur with atmospheric pressure applied for gage transducers. Absolute and compound transducers should be adjusted while a full vacuum is applied. Compound transducers may alternatively be adjusted at atmospheric pressure using the values in Diagram 6.



**WARNING:** Pressure should be applied with inert gases or clean air only. For transducers with ATEX Ex marking, no adjustment should be made in the presence, or potential for, hazardous atmosphere.

#### NOMINAL "INSTALLED" OUTPUT AT ATMOSPHERIC PRESSURE

BAR COMPOUND RANGE	CURRENT OUTPUT (mA)	PSI COMPOUND RANGE	CURRENT OUTPUT (mA)
-1 to 1.7	9.93	-14.7 to 25	9.92
-1 to 3.4	7.64	-14.7 to 50	7.64
-1 to 7	6.00	-14.7 to 100	6.05
-1 to 17	4.89	-14.7 to 250	4.89
-1 to 35	4.44	-14.7 to 500	4.46
-1 to 70	4.23	-14.7 to 1000	4.23
-1 to 200	4.08	-14.7 to 3000	4.08

Diagram 6

### 4.4 CURRENT OUTPUT SPAN ADJUSTMENT

Zero adjustment must be performed prior to span adjustment. Span adjustment should only be performed by use of an appropriate pressure standard (electric manometer, digital pressure gauge, etc) with at least 4X the accuracy of a model 227. The span may be adjusted by turning the span potentiometer while full scale pressure is applied to the pressure port.



**WARNING:** Pressure should be applied with inert gases or clean air only. For transducers with ATEX Ex marking, no adjustment should be made in the presence, or potential for, hazardous atmosphere.

## 6.0 RETURNING PRODUCTS FOR REPAIR

Please contact Setra (1-800-257-3872, (978) 263-1400) before returning unit for repair to review information to your application. Many times, only minor field adjustments may be necessary. When returning a product to Setra, the material should be carefully packaged, accompanied by the "Service/Repair/Calibration Order Return" and shipped to:

Setra Systems, Inc.  
159 Swanson Road  
Boxborough, MA 01719  
Attn: Repair Department

**Note: Return order form is available on Setra's web site @ [www.setra.com](http://www.setra.com).**

To assure prompt handling, please supply the following information and include it inside the package of returned material.

1. Name and phone number of person to contact.
2. Shipping and billing instructions.
3. Full description of the problem.
4. Identify any hazardous material used with product.

Notes: Please remove any pressure fittings and plumbing that you have installed and enclose any required mating electrical connectors and wiring diagrams.

Allow approximately 3 weeks after receipt at Setra for the repair and return of the unit. Non warranty repairs will not be made without customer approval and a purchase order to cover repair charges.

## CALIBRATION SERVICES

Setra maintains a complete calibration facility that is traceable to the National Institute of Standards & Technology (NIST). If you would like to recalibrate or recertify your Setra pressure transducers, please call our Repair Department at 1-800-257-3872 (978-263-1400) for scheduling, cost and turnaround estimates.

## 7.0 LIMITED WARRANTY AND LIMITATION OF LIABILITY

SETRA warrants its Model 227 to be free from defects in materials and workmanship, subject to the following terms and conditions: Without charge, SETRA will repair or replace products found to be defective in materials or workmanship within the warranty period; provided that:

- a) the product has not been subjected to abuse, neglect, accident, incorrect wiring not our own, improper installation or servicing, or use in violation of instructions furnished by SETRA;
- b) the product has not been repaired or altered by anyone except SETRA or its authorized service agencies;
- c) the serial number or date code has not been removed, defaced, or otherwise changed; and
- d) examination discloses, in the judgment of SETRA, the defect in materials or workmanship developed under normal installation, use and service;
- e) SETRA is notified in advance of and the product is returned to SETRA transportation prepaid.

Unless otherwise specified in a manual or warranty card, or agreed to in a writing signed by a SETRA officer, SETRA pressure and acceleration products shall be warranted for one year from date of sale.

The foregoing warranty is in lieu of all warranties, express, implied or statutory, including but not limited to, any implied warranty of merchantability for a particular purpose.

SETRA's liability for breach of warranty is limited to repair or replacement, or if the goods cannot be repaired or replaced, to a refund of the purchase price. SETRA's liability for all other breaches is limited to a refund of the purchase price. In no instance shall SETRA be liable for incidental or consequential damages arising from a breach of warranty, or from the use or installation of its products.

No representative or person is authorized to give any warranty other than as set out above or to assume for SETRA any other liability in connection with the sale of its products.

---

For all CE technical questions, contact Setra Systems, USA. EU customers may contact our EU representative Hengstler GmbH, Uhlandstr 49, 78554 Aldingen, Germany (Tel: +49-7424-890; Fax: +49-7424-89500).