

# ProtEX-MAX PD8-765 Explosion-Proof Process & Temperature Meter Instruction Manual



Process & Temperature

- Accepts Current, Voltage, TC, & RTD Inputs
- 4 Digit Display, 0.56" (14 mm) or 1.20" (31 mm)
- Linear or Square Root with Low-Flow Cutoff
- Operating temperature range of between -40°C and 65°C
- Maximum/Minimum Display
- Type 4X, NEMA 4X, IP65 Front
- Universal Power Supply 85-265 VAC
- 12-36 VDC/12-24 VAC Power Option
- Two Relays and 4-20 mA Output Option
- 24 VDC Transmitter Power Supply Options
- USB, RS-232, & RS-485  
Serial Communication Adapters Options
- Free Modbus® RTU Protocol
- Copy Meter Settings to Other Meters
- Free MeterView® Software - Configuration & Data Acquisition

## PRECISION DIGITAL CORPORATION



233 South Street • Hopkinton MA 01748 USA  
Tel (800) 343-1001 • Fax (508) 655-8990

PRECISION  
DIGITAL

[www.predig.com](http://www.predig.com)

## Disclaimer

The information contained in this document is subject to change without notice. Precision Digital makes no representations or warranties with respect to the contents hereof, and specifically disclaims any implied warranties of merchantability or fitness for a particular purpose.

	
<p><b>CAUTION:</b> <i>Read complete instructions prior to installation and operation of the meter.</i></p>	<p><b>WARNING:</b> <i>Risk of electric shock or personal injury.</i></p>

 <p><b>Warning!</b></p>	<ul style="list-style-type: none"> <li>• <b><i>This product is not recommended for life support applications or applications where malfunctioning could result in personal injury or property loss. Anyone using this product for such applications does so at his/her own risk. Precision Digital Corporation shall not be held liable for damages resulting from such improper use.</i></b></li> <li>• <b><i>Failure to follow installation guidelines could result in death or serious injury. Make sure only qualified personnel perform the installation.</i></b></li> <li>• <b><i>Never remove the instrument cover in explosive environments when the circuit is live.</i></b></li> <li>• <b><i>Cover must be fully engaged to meet flameproof/explosion-proof requirements.</i></b></li> <li>• <b><i>Information in this manual supersedes all enclosure, compliance, and agency approval information included in additional product manuals included with this product.</i></b></li> </ul>
--	---

## Limited Warranty

Precision Digital Corporation warrants this product against defects in material or workmanship for the specified period under “Specifications” from the date of shipment from the factory. Precision Digital’s liability under this limited warranty shall not exceed the purchase value, repair, or replacement of the defective unit.

## Registered Trademarks

MeterView® is a registered trademark of Precision Digital Corporation, Modbus® is a registered trademark of Schneider Automation Inc. All other trademarks mentioned in this document are the property of their respective owners.

© 2018 Precision Digital Corporation. All rights reserved.

## Table of Contents

<b>Table of Contents</b> .....	<b>3</b>	Setting the Decimal Point ( <i>dc.Pt</i> ) .....	22
<b>Table of Figures</b> .....	<b>3</b>	Setting the Temperature Scale ( <i>F °C</i> ) .....	22
<b>Introduction</b> .....	<b>4</b>	Programming the Meter ( <i>Prog</i> ) .....	23
<b>Ordering Information</b> .....	<b>4</b>	Scaling the Meter ( <i>ScAL</i> ) .....	23
<b>Specifications</b> .....	<b>5</b>	Calibrating the Meter ( <i>LRl</i> ) .....	24
<b>General</b> .....	<b>5</b>	Recalibrating Temperature Inputs ( <i>LRl</i> ) .....	24
<b>Process Input</b> .....	<b>5</b>	Recalibrating Process Inputs ( <i>LRl</i> ) .....	25
<b>Temperature Inputs</b> .....	<b>5</b>	Setting the Relay Operation ( <i>RELY</i> ) .....	26
<b>Relays Option</b> .....	<b>6</b>	Relay and Alarm Operation .....	28
<b>Isolated 4-20 mA Transmitter Output</b> .....	<b>6</b>	Scaling the 4-20 mA Analog Output ( <i>RAut</i> ) .....	31
<b>External Switch Contacts</b> .....	<b>6</b>	Program the Sensor Break Output Value ( <i>SEbr</i> ) .....	31
<b>Serial Communications</b> .....	<b>6</b>	Analog Output when Display is Out of Range .....	32
<b>Product Ratings and Approvals</b> .....	<b>7</b>	<b>Setting Up the Password (<i>PR55</i>)</b> .....	<b>32</b>
<b>Compliance Information</b> .....	<b>8</b>	Locking the Meter .....	32
<b>Safety</b> .....	<b>8</b>	Unlocking the Meter .....	32
<b>Electromagnetic Compatibility</b> .....	<b>8</b>	<b>Advanced Features Menu</b> .....	<b>33</b>
<b>Safety Information</b> .....	<b>9</b>	Advanced Features Menu & Display Messages .....	33
<b>Installation</b> .....	<b>9</b>	Offset Adjustment ( <i>Adj</i> ) .....	34
<b>Unpacking</b> .....	<b>10</b>	Noise Filter ( <i>FLtr</i> ) .....	34
<b>Pre-Installed Conduit/Stopping Plug</b> .....	<b>10</b>	Noise Filter Bypass ( <i>bYP5</i> ) .....	34
<b>Mounting</b> .....	<b>10</b>	Serial Communications ( <i>SERL</i> ) .....	35
<b>Cover Jam Screw</b> .....	<b>10</b>	Protocol Selection Menu ( <i>Prat</i> ) .....	35
<b>Connections</b> .....	<b>11</b>	Select Menu ( <i>SELC</i> ) .....	35
<b>Required &amp; Factory Wired Connections</b> .....	<b>11</b>	Linear or Square Root Function ( <i>LInr</i> or <i>SqrT</i> ) .....	35
Connector Labeling .....	12	Low-Flow Cutoff ( <i>cuTF</i> ) .....	36
Power Connections .....	12	Display Intensity ( <i>INTY</i> ) .....	36
Signal Connections .....	13	Meter Copy Function ( <i>CoPY</i> ) .....	37
Serial Communication .....	15	Internal Calibration ( <i>LRl</i> ) .....	38
Relays and 24 V Output Connections .....	15	<b>Operation</b> .....	<b>40</b>
Switching Inductive Loads .....	15	<b>Front Buttons Operation</b> .....	<b>40</b>
4-20 mA Output & Input Signal Connections .....	16	<b>SafeTouch® Buttons</b> .....	<b>40</b>
<b>External Switch Contacts</b> .....	<b>16</b>	<b>Maximum/Minimum Readings</b> .....	<b>41</b>
<b>Setup and Programming</b> .....	<b>17</b>	<b>Service</b> .....	<b>41</b>
<b>SafeTouch® Buttons</b> .....	<b>17</b>	<b>Mounting Dimensions</b> .....	<b>42</b>
<b>Front Buttons and Status LED Indicators</b> .....	<b>18</b>	<b>Troubleshooting</b> .....	<b>42</b>
<b>Display Functions and Messages</b> .....	<b>19</b>	<b>Diagnostics Menu (<i>d iAG</i>)</b> .....	<b>42</b>
<b>Main Menu</b> .....	<b>20</b>	Determining Software Version .....	42
<b>Setting Numeric Values</b> .....	<b>20</b>	<b>Reset Meter to Factory Defaults</b> .....	<b>43</b>
<b>Setting Up the Meter (<i>SEtU</i>)</b> .....	<b>21</b>	Factory Defaults & User Settings .....	44
Setting the Input Signal ( <i>INPt</i> ) .....	21	<b>Troubleshooting Tips</b> .....	<b>45</b>
		<b>Quick Interface Reference Guide</b> .....	<b>47</b>
		<b>EU Declaration of Conformity</b> .....	<b>49</b>

## Table of Figures

<b>Figure 1: Integrated Trident X2 (PD8-765) Required Connections</b> .....	<b>11</b>	<b>Figure 9. Three-Wire RTD Input Connections</b> .....	<b>14</b>
<b>Figure 2. Labeling for 2 Relay, Analog Out, &amp; 24 V Supply</b> .....	<b>12</b>	<b>Figure 10. Two-Wire RTD Input Connections</b> .....	<b>14</b>
<b>Figure 3. Labeling for Analog Out &amp; Two 24 V Supply Model</b> .....	<b>12</b>	<b>Figure 11. Four-Wire RTD Input Connections</b> .....	<b>14</b>
<b>Figure 4. Power Connections</b> .....	<b>12</b>	<b>Figure 12. Relay &amp; 24 V Output Connections</b> .....	<b>15</b>
<b>Figure 5. Transmitter Powered by Ext. Supply or Self-Powered</b> .....	<b>13</b>	<b>Figure 13. AC and DC Loads Protection</b> .....	<b>15</b>
<b>Figure 6. Transmitters Powered by Internal Supply (Optional)</b> .....	<b>13</b>	<b>Figure 14. Low Voltage DC Loads Protection</b> .....	<b>15</b>
<b>Figure 7. Voltage Input Connections</b> .....	<b>13</b>	<b>Figure 15. 4-20 mA Output &amp; Input Signal Powered by Meter</b> .....	<b>16</b>
<b>Figure 8. Thermocouple Input Connections</b> .....	<b>14</b>	<b>Figure 16. 4-20 mA Output Powered Externally</b> .....	<b>16</b>
		<b>Figure 17: External Switch Contacts</b> .....	<b>16</b>
		<b>Figure 18: Enclosure Dimensions – Front View</b> .....	<b>42</b>
		<b>Figure 19: Enclosure Dimensions – Side Cross Section View</b> .....	<b>42</b>

## Introduction

The ProtEX-MAX PD8-765 explosion-proof, large-display, process and temperature meter offers all the functionality of the Trident X2 as a fully FM, CSA, ATEX, and IECEx approved explosion-proof product. PD8-765's huge 1.2" (30.5 mm) sunlight readable display that is visible from over 30 feet away. This explosion-proof indicator can be field programmed to accept process voltage (0-5 V, 1-5 V, etc.) and current (4-20 mA) inputs, 100 Ohm RTDs, and the four most common thermocouples.

The intensity of the display can be adjusted to compensate for various lighting conditions, including direct sunlight. The meter can be programmed and operated without opening the housing by using the built-in SafeTouch® through-glass buttons or the RS485 serial communication port with free Modbus® protocol. Options for the PD8-765 process and temperature indicator include 2 relays, a 4-20 mA output, and a 24 V transmitter power supply.

## Ordering Information

85-265 VAC Model	12-36 VDC Model	Options Installed
PD8-765-6X0-00	PD8-765-7X0-00	No options
PD8-765-6X0-10		24 V transmitter supply
PD8-765-6X2-00	PD8-765-7X2-00	2 relays
PD8-765-6X2-10		2 relays & 24 V transmitter supply
PD8-765-6X3-00	PD8-765-7X3-00	4-20 mA output
PD8-765-6X3-10		4-20 mA output & 24 V supply
PD8-765-6X3-20		4-20 mA output & dual 24 V supplies
	PD8-765-7X5-00	2 relays & 4-20 mA output
PD8-765-6X5-10		2 relays, 4-20 mA output, & 24 V supply

### Accessories

Model	Description
PDA7232	RS-232 serial adapter with PDA7420 included
PDA7420	Trident meter copy cable, 7' (2.1 m)
PDA7422	RS-485 serial adapter with PDA7420 included
PDA7485-I	RS-232 to RS-485 isolated converter
PDA7485-N	RS-232 to RS-485 non-isolated converter
PDA8485-I	USB to RS-422/485 isolated converter
PDA8485-N	USB to RS-422/485 non-isolated converter
PDA8006	USB Serial Adapter
MeterView®	Free MeterView® software download at <a href="http://www.predig.com">www.predig.com</a>

## Specifications

Except where noted all specifications apply to operation at +25°C.

### General

<b>Display</b>	Trident: 0.56" (14 mm), Trident X2: 1.20" (31 mm), Four digits (-1999 to 9999), automatic lead zero blanking.		
<b>Display Intensity</b>	Eight intensity levels		
<b>Display Update Rate</b>	Process/RTD: 3.7-5/second Thermocouple: 1.8-2.5/second		
<b>Overrange</b>	Display flashes 9999		
<b>Underrange</b>	Display flashes - 1999		
<b>Programming Methods</b>	Four front panel buttons, PC and MeterView® software, or cloning using Copy function		
<b>Noise Filter</b>	Programmable from 2 to 199 (0 will disable filter)		
<b>Recalibration</b>	All ranges are calibrated at the factory. Recalibration is recommended at least every 12 months.		
<b>Max/Min Display</b>	Max/min readings reached by the process are stored until reset by the user or until power to the meter is turned off.		
<b>Password</b>	Programmable password restricts modification of settings.		
<b>Non-Volatile Memory</b>	All programmed settings are stored in non-volatile memory for a minimum of ten years if power is lost.		
<b>Power Options</b>	85-265 VAC, 50/60 Hz 90- 265 VDC, 20 W max or 12-36 VDC, 12-24 VAC, 6 W max. See table for power consumption. (*X: number depends on option)	Model	Watts
		PD765-6RX-0*	8
		PD765-6RX-1, 2*	20
		PD765-7RX-0*	6
<b>Fuse</b>	Required fuse: UL Recognized, 5 A max, slow blow Up to 6 meters may share one 5 A fuse		
<b>Isolated Transmitter Power Supply</b>	One or two transmitter power supplies (Optional) P or P1: 24 VDC ± 10% @ 200 mA max. (-1 option) P1 & P2: 24 VDC ± 10% @ 200 mA & 40 mA max. (-2 option)		
<b>Normal Mode Rejection</b>	64 dB at 50/60 Hz		
<b>Isolation</b>	4 kV input/output-to-power line 500 V input-to-output or output-to-P1/P2 supplies -6R5 & -6X5 models only: 100 V output-to-24 VDC supply		
<b>Overvoltage Category</b>	Installation Overvoltage Category II: Local level with smaller transient overvoltages than Installation Overvoltage Category III.		
<b>Environmental</b>	Operating temperature range: -40 to 65°C Storage temperature range: -40 to 85°C Relative humidity: 0 to 90% non-condensing		

<b>Connections</b>	Removable screw terminal blocks accept 12 to 22 AWG wire, RJ11 for serial communication adapters
<b>Enclosure</b>	1/8 DIN, high impact plastic, UL 94V-0, color: gray
<b>Mounting</b>	1/8 DIN panel cutout required. Two panel mounting bracket assemblies provided
<b>Tightening Torque</b>	Screw terminal connectors: 5 lb-in (0.56 Nm)
<b>Overall Dimensions</b>	2.45" x 4.68" x 4.19" (62 mm x 119 mm x 106 mm) (H x W x D)
<b>Weight</b>	9.5 oz. (269 g) (including options)
<b>Warranty</b>	3 years parts & labor

### Process Input

<b>Inputs</b>	Field selectable: ±20 mADC (0-20, 4-20 mA) and ±10 VDC (0-5, 1-5, 0-10 V)	
<b>Accuracy</b>	±0.05% of span ±1 count, square root: 10-100% FS	
<b>Function</b>	Linear or square root	
<b>Low-Flow Cutoff</b>	0-9999 (0 disables cutoff function)	
<b>Temperature Drift</b>	<b>0 to 65°C ambient</b> Current: ±0.20% FS (50 PPM/°C) Voltage: ±0.02% FS (1.7 PPM/°C)	<b>-40 to 0°C ambient</b> Current: ±0.80% FS Voltage: ±0.06% FS
<b>Decimal Point</b>	Up to three decimal places for process inputs: d.ddd, dd.dd, ddd.d, or dddd	
<b>Calibration Range</b>	An <i>Error</i> message will appear if input 1 and input 2 signals are too close together.	
	<b>Input Range</b>	<b>Minimum Span Input 1 &amp; Input 2</b>
	4-20 mA	0.40 mA
	±10 V	0.20 V
<b>Input Impedance</b>	Voltage ranges: greater than 1 MΩ Current ranges: 50 - 100 Ω (depending on resettable fuse impedance)	
<b>Input Overload</b>	Current input protected by resettable fuse. Fuse resets automatically after fault is removed.	
<b>HART Transparency</b>	Analog input will not interfere with existing HART communications on the wired 4-20 mA signal	

### Temperature Inputs

<b>Inputs</b>	Field selectable: type J, K, T, or E thermocouples; 100 Ω platinum RTD (0.00385 or 0.00392 curve)
<b>Resolution</b>	1° or 0.1° for all RTD inputs. 1° for all thermocouples. 1° or 0.1° for Type T thermocouple

<b>Cold Junction Reference</b>	Automatic, fixed, no user calibration needed
<b>Offset Adjustment</b>	Programmable to $\pm 19.9^\circ$ . This parameter allows the user to apply an offset value to the temperature being displayed.

**Accuracy**

Input Type	Range	Accuracy (0 - 65 C)	Accuracy (-40 - 0 C)
Type J	-58° to 1382° F -50° to 750°C	$\pm 2^\circ\text{F}$ $\pm 1^\circ\text{C}$	$\pm 5^\circ\text{F}$ $\pm 3^\circ\text{C}$
Type K	-58° to 2300° F -50° to 1260°C	$\pm 2^\circ\text{F}$ $\pm 1^\circ\text{C}$	$\pm 4^\circ\text{F}$ $\pm 2^\circ\text{C}$
Type T	-292° to 700° F -180° to 371°C	$\pm 2^\circ\text{F}$ $\pm 1^\circ\text{C}$	$\pm 13^\circ\text{F}$ $\pm 7^\circ\text{C}$
Type T 0.1° Res	-199.9° to 700.0° F -180.0° to 371.0°C	$\pm 1.8^\circ\text{F}$ $\pm 1.0^\circ\text{C}$	$\pm 13^\circ\text{F}$ $\pm 7.2^\circ\text{C}$
Type E	-58° to 1578° F -50° to 870°C	$\pm 2^\circ\text{F}$ $\pm 1^\circ\text{C}$	$\pm 11^\circ\text{F}$ $\pm 6^\circ\text{C}$
100 $\Omega$ Rtd	-328° to 1382°F -200° to 750°C	$\pm 1^\circ\text{F}$ $\pm 1^\circ\text{C}$	$\pm 5^\circ\text{F}$ $\pm 3^\circ\text{C}$

<b>Input Impedance</b>	Greater than 100 k $\Omega$
<b>Sensor Break Detection</b>	Open TC or RTD sensor indicated by display flashing <b>oPEr</b> . All relays and alarm status LEDs go to alarm or non-alarm state, programmable for each relay individually. Analog output goes to the programmed sensor break value.

**Relays Option**

<b>Rating</b>	2 SPDT (Form C); rated 3 A @ 30 VDC or 3 A @ 250 VAC resistive load; 1/14 HP @ 125/250 VAC (50 watts) for inductive loads
<b>Electrical Noise Suppression</b>	A suppressor (snubber) should be connected to each relay contact switching inductive loads to prevent disruption to the microprocessor's operation. Recommended suppressor value: 0.01 $\mu\text{F}/470 \Omega$ , 250 VAC (PDX6901).
<b>Deadband</b>	0-100% of full scale, user selectable
<b>High or Low Alarm</b>	User may program any alarm for high or low trip point.
<b>Relay Operation</b>	Automatic (non-latching) Latching Pump alternation control
<b>Relay Reset</b>	User selectable via front panel buttons or PC Automatic reset only (non-latching) Automatic + manual reset at any time (non-latching) Manual reset only, at any time (latching) Manual reset only after alarm condition has cleared (latching) Automatic reset: Relays will automatically reset when the input passes the reset point. Manual reset: Front panel ACK button. Pressing ACK resets all manually resettable relays.

<b>Time Delay</b>	0 to 199 seconds, on and off delays Programmable and independent for each relay
<b>Auto Initialization</b>	When power is applied to the meter, relays will reflect the state of the input to the meter.
<b>Fail-Safe Operation</b>	Programmable Independent for each relay

**Fail-safe operation:** relay coil is energized in non-alarm condition. In case of power failure, relay will go to alarm state.

**Isolated 4-20 mA Transmitter Output**

<b>Output Range</b>	1.00 to 23.00 mA typical
<b>Calibration</b>	Factory calibrated for 4-20 mA
<b>Scaling Range</b>	0.00 to 23.99 mA for any display range, see output range above
<b>Accuracy</b>	$\pm 0.1\%$ FS $\pm 0.004$ mA
<b>Temperature Drift</b>	0.4 $\mu\text{A}/^\circ\text{C}$ from -40 to 65°C ambient Note: Analog output drift is separate from input drift.
<b>Isolated Transmitter Power Supply</b>	One or two transmitter power supplies (Optional) P1: 24 VDC $\pm 10\%$ @ 200 mA max. (-1 option) P1 & P2: 24 VDC $\pm 10\%$ @ 200 mA & 40 mA max. (-2 option)

<b>External Loop Power Supply</b>	35 VDC maximum
<b>Output Loop Resistance</b>	Power supply      Minimum      Maximum
	24 VDC                      10 $\Omega$ 700 $\Omega$
	35 VDC (external)      100 $\Omega$ 1200 $\Omega$

**External Switch Contacts**

<b>Open State</b>	+5 VDC open contact on switch input terminals
<b>Closed State</b>	Closed contact switch input terminal to common/ground, active low 0 to 0.4 VDC, or open collector transistor activated input

**Serial Communications**

<b>Meter Address</b>	PDC protocol: 0 - 99 Modbus protocol: 1 - 247
<b>Baud Rate</b>	300 - 19,200 bps
<b>Transmit Time Delay</b>	Programmable between 0 and 199 ms
<b>Data</b>	8 bit (1 start bit, 1 stop bit)
<b>Parity</b>	None (1 or 2 stop bits), even, or odd (Modbus only; PDC protocol does not use parity)
<b>Byte-To-Byte Timeout</b>	0.01 - 2.54 sec (Modbus only)
<b>Turn Around Delay</b>	Less than 2 ms (fixed)

**Refer to PDC and Modbus Serial Communication Protocol manuals for details. These can be downloaded from: [www.predig.com](http://www.predig.com).**

## Product Ratings and Approvals

---

<b>FM</b>	Enclosure: Type 4X; IP66 Class I, Division 1, Groups B, C, D Class II, Division 1, Groups E, F, G Class III, Division 1, T5/T6 Class I, Zone 1, AEx d, IIC Gb T5/T6 Zone 21, AEx tb IIIC T90°C; Ta -40°C to +65°C T6 Ta = -40°C to +60°C; T5 Ta = -40°C to +65°C Certificate Number: 3047283
<b>CSA</b>	Class I, Division 1, Groups B, C, D Class II, Division 1, Groups E, F, G Class III, Division 1 Class I Zone 1 Ex d IIC Zone 21 Ex tb IIIC T90°C -40°C < Tamb. < +60° C; Temperature Code T6 -40°C < Tamb. < +65° C; Temperature Code T5 Enclosure Type 4X & IP66 Certificate Number: 2531731
<b>ATEX</b>	 II 2 G D Ex d IIC T* Gb Ex tb IIIC T90°C Db IP68 Ta = -40°C to +*°C *T6 = -40°C to +60°C *T5 = -40°C to +65°C Certificate number: Sira 12ATEX1182
<b>IECEX</b>	Ex d IIC T* Gb Ex tb IIIC T90°C Db IP68 Ta = -40°C to +*°C *T6 = -40°C to +60°C *T5 = -40°C to +65°C Certificate Number: IECEX SIR 12.0073

---

### **Special Conditions for Safe Use:**

Use suitably certified and dimensioned cable entry device and/or plug. The equipment shall be installed such that the supply cable is protected from mechanical damage. The cable shall not be subjected to tension or torque. If the cable is to be terminated within an explosive atmosphere, then appropriate protection of the free end of the cable shall be provided. Cable must be suitable for 90°C.

### **Year of Construction**

This information is contained within the serial number with the first four digits representing the year and month in the YYMM format.

**For European Community:** The ProtEX-MAX must be installed in accordance with the ATEX directive 94/9/EC, and the product certificate Sira 12ATEX1182.

## Compliance Information

### Safety

<b>UL Listed</b>	USA and Canada UL 508 Industrial Control Equipment
<b>UL File Number</b>	E160849
<b>Front Panel</b>	UL Type 4X, NEMA 4X, IP65; panel gasket provided
<b>Low Voltage Directive</b>	EN 61010-1:2010 Safety requirements for measurement, control, and laboratory use

### Electromagnetic Compatibility

<b>Emissions</b>	EN 55011:2009 + A1:2010 Group 1 Class A ISM emissions requirements
Radiated Emissions	Class A
AC Mains Conducted Emissions	Class A
<b>Immunity</b>	EN 61326-1:2013 Measurement, control, and laboratory equipment EN 61000-6-2:2005 EMC heavy industrial generic immunity standard
RFI - Amplitude Modulated	80 -1000 MHz 10 V/m 80% AM (1 kHz) 1.4 - 2.0 GHz 3 V/m 80% AM (1 kHz) 2.0 - 2.7 GHz 1 V/m 80% AM (1 kHz)
Electrical Fast Transients	±2kV AC mains, ±1kV other
Electrostatic Discharge	±4kV contact, ±8kV air
RFI - Conducted	10V, 0.15-80 MHz, 1kHz 80% AM
AC Surge	±2kV Common, ±1kV Differential
Surge	1KV (CM)
Power-Frequency Magnetic Field	30 A/m 70%V for 0.5 period
Voltage Dips	40%V for 5 & 50 periods 70%V for 25 periods
Voltage Interruptions	<5%V for 250 periods

**Note:**

Testing was conducted on Trident Meters installed through the covers of grounded metal enclosures with cable shields grounded at the point of entry representing installations designed to optimize EMC performance.

*Declaration of Conformity available at [www.predig.com](http://www.predig.com)*



## Safety Information



### WARNINGS

- Read complete instructions prior to installation and operation of the instrument.
- Installation and service should be performed only by trained service personnel. Service requiring replacement of internal sub-components must be performed at the factory.
- Disconnect from supply before opening enclosure. Keep cover tight while circuits are alive. Conduit seals must be installed within 18" (450mm) of the enclosure or within 2" (50mm) for Zone installations.
- Verify that the operating atmosphere of the instrument is consistent with the appropriate hazardous locations certifications.
- If the instrument is installed in a high voltage environment and a fault or installation error occurs, high voltage may be present on any lead
- Read all product labels completely and follow all instructions and requirements listed on the labels for installation or service.

## Installation

*Install in accordance with applicable local and national regulations (e.g. NEC).*

**For Installation in USA:** The ProtEX-MAX must be installed in accordance with the National Electrical Code (NEC) NFPA 70.

**For Installation in Canada:** The ProtEX-MAX must be installed in accordance with the Canadian Electrical Code CSA 22.1. All power supplies below 36 V and input circuits must be derived from a CSA Approved Class 2 source.

**For European Community:** The ProtEX-MAX must be installed in accordance with the ATEX directive 94/9/EC and the product certificate Sira 12ATEX1182.



### WARNING

Disconnect from supply before opening enclosure. Keep cover tight while circuits are alive. Conduit seals must be installed within 18" (450mm) of the enclosure or within 2" (50mm) for Zone installations.

Wiring connectors are accessed by opening the enclosure. To access electrical connectors, remove the 2 captive screws and then remove the electronics module. Connectors are on the rear of the electronics module.

## Unpacking

Remove the instrument from packing box. Inspect the packaging and contents for damage. Report damages, if any, to the carrier.

If any part is missing or the instrument malfunctions, please contact your supplier or the factory for assistance.

## Pre-Installed Conduit/Stopping Plug

The PD8-765 is supplied with two pre-installed conduit plugs for installations that do not require the use of all conduit entries. The conduit/stopping plugs include an internal 12mm hexagonal socket recess for removal. The pre-installed plugs and their installation are included in the hazardous area approvals for the PD8 Series enclosure.

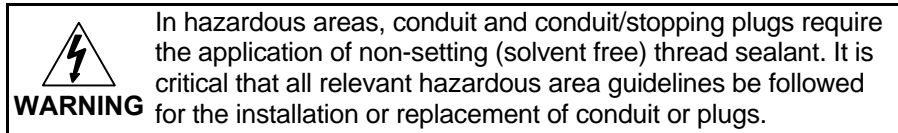

## Mounting

The ProtEX-MAX has four slotted mounting flanges that should be used for pipe mounting or wall mounting. Refer to *Mounting Dimensions*, page 42 for details.

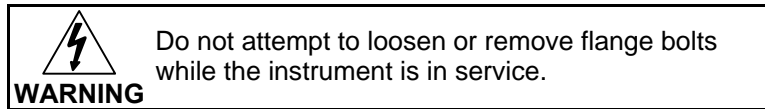

## Cover Jam Screw

The cover jam screw should be properly installed once the instrument has been wired and tested in a safe environment. The cover jam screw is intended to prevent the removal of the instrument cover in a flameproof environment without the use of tools. Using a M2 hex wrench, turn the screw clockwise until the screw contacts the aluminum enclosure. Turn the screw an additional 1/4 to 1/2 turn to secure the cover. Caution: Excess torque may damage the threads and/or wrench.

## Connections



**WARNINGS**

- Static electricity can damage sensitive components.
- Observe safe handling precautions for static-sensitive components.
- Use proper grounding procedures/codes.
- If the instrument is installed in a high voltage environment and a fault or installation error occurs, high voltage may be present on any lead or terminal.
- Follow all fusing and wiring precautions requirements for the instrument integrated to the PD8 Series model number being connected.

To access the connectors, remove the enclosure cover and unscrew the two captive screws that fasten the electronics module. Signal connections are made to de-pluggable connectors on the back of the electronics module.

Some connectors may be provided already connected. These connections are required for proper operation of the ProtEX-MAX, and should not be removed unless instructed to by this manual.

Wires marked as being used for testing purposes should be removed.

Grounding connections are made to the two ground screws provided on the base – one internal and one external.

After all connections have been completed and verified, apply power to the unit.

## Required & Factory Wired Connections

ProtEX-MAX units with Trident X2 integrated functionality have two factory wired connectors. A modular cable must connect from the rear of the integrated Trident X2 electronics to the ProtEX-MAX connector board. The Trident X2 integrated models also have a 5 position external switch connector wired from the rear of the integrated Trident X2 electronics to the ProtEX-MAX connector board as shown below. This must remain connected as shown to the ProtEX-MAX connector board for the SafeTouch Buttons to function on these models.



**WARNING** Observe all safety regulations. Electrical wiring should be performed in accordance with all agency requirements and applicable national, state, and local codes to prevent damage to the meter and ensure personnel safety.



**NOTICE** The connections described in this section must remain connected for the SafeTouch buttons to function.

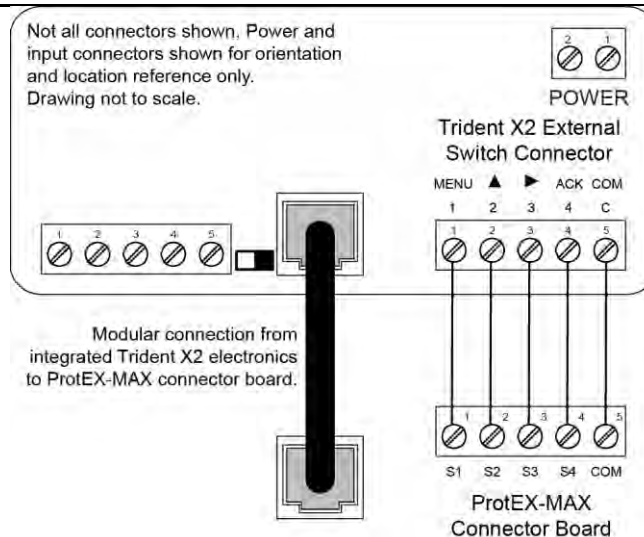

**Figure 1: Integrated Trident X2 (PD8-765) Required Connections**

### Connector Labeling

The connectors label, affixed to the meter, shows the location of all connectors available with requested configuration. It also identifies the location of the RTD/TC selector switch. The below two images are common connector configurations for the PD765. Note that the connector in the upper left of the diagram has two different configurations based on the model.

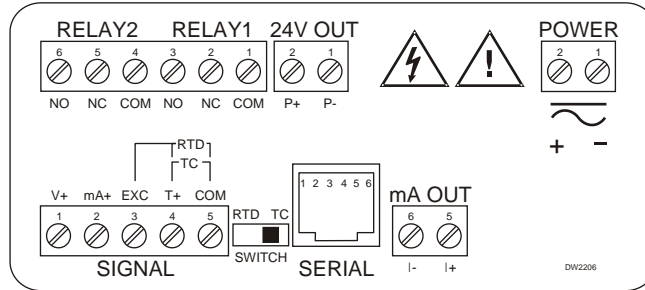

Figure 2. Labeling for 2 Relay, Analog Out, & 24 V Supply

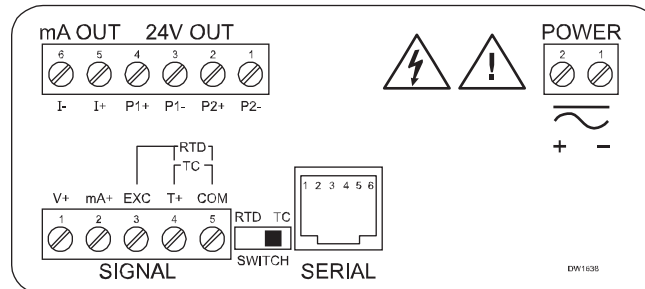

Figure 3. Labeling for Analog Out & Two 24 V Supply Model

### Power Connections

Power connections are made to a two-terminal connector labeled POWER on Figure 2. The meter will operate regardless of DC polarity connection. The + and - symbols are only a suggested wiring convention.

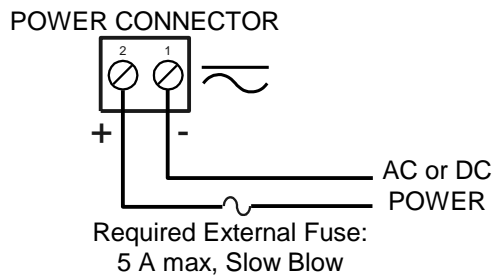

Figure 4. Power Connections

### Signal Connections

Signal connections are made to a five-terminal connector labeled SIGNAL on Figure 2. The COM (common) terminal is the return for all types of input signals.

#### Current and Voltage Connections

The following figures show examples for current and voltage connections.

There are no switches or jumpers to set up for current and voltage inputs. Setup and programming is performed through the front panel buttons.

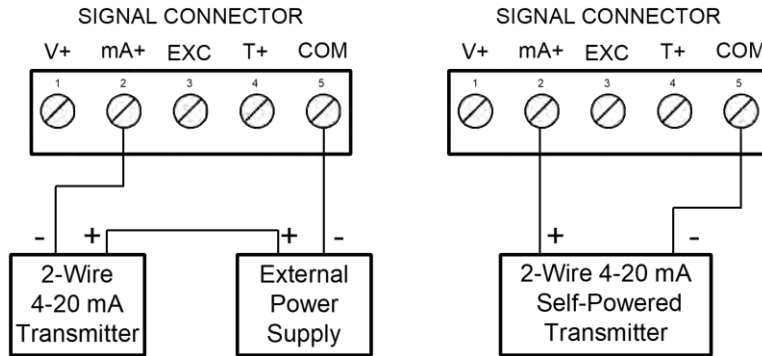

**Figure 5. Transmitter Powered by Ext. Supply or Self-Powered**

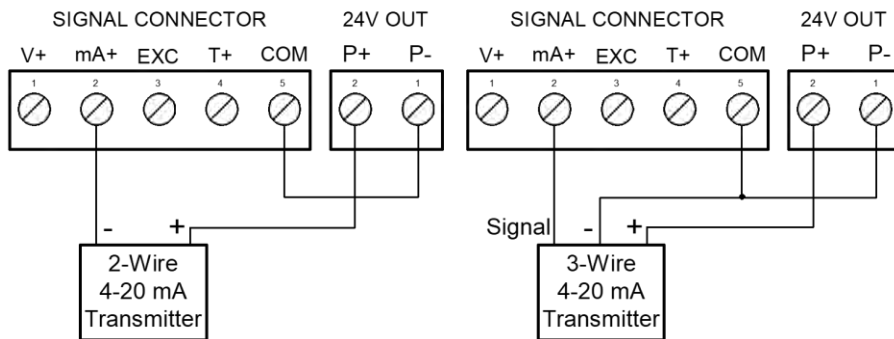

**Figure 6. Transmitters Powered by Internal Supply (Optional)**

The current input is protected against current overload by a resettable fuse. The display may or may not show a fault condition depending on the nature of the overload.

The fuse limits the current to a safe level when it detects a fault condition, and automatically resets itself when the fault condition is removed.

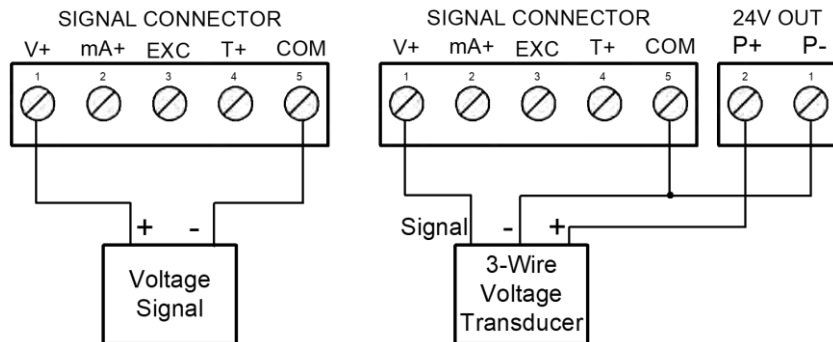

**Figure 7. Voltage Input Connections**

The meter is capable of accepting any voltage from -10 VDC to +10 VDC.

### Thermocouple and RTD Connections

The following figures show examples for thermocouple and RTD connections.

The RTD/TC selector switch must be set to the proper position for the meter to accept the selected temperature input.

The input type is selected using the *Setup* menu.

Selected thermocouple input must correspond to thermocouple sensor and wire type used.

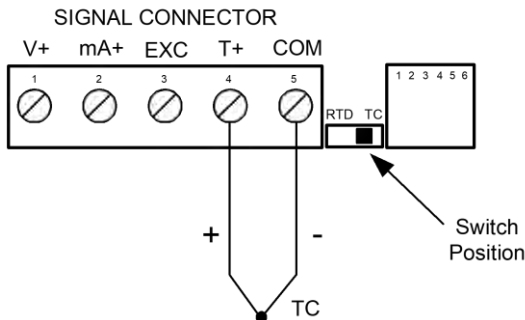

Figure 8. Thermocouple Input Connections

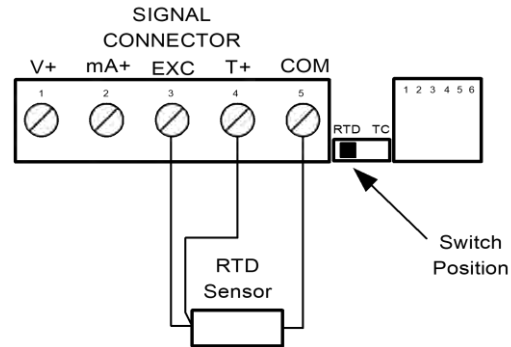

Figure 9. Three-Wire RTD Input Connections

The meter accepts two, three, or four-wire RTDs. The three-wire RTD connection has built-in lead wire compensation.

Lead wire compensation for two-wire RTDs can be applied using the *Adjust* menu. See Offset Adjustment (*RdJ*), page 34.

The four-wire RTD connection is similar to the three-wire. One of the leads of a four-wire RTD is not connected, and may be clipped off.

The three-wire connection provides sufficient lead wire compensation to provide accurate readings even with long leads.

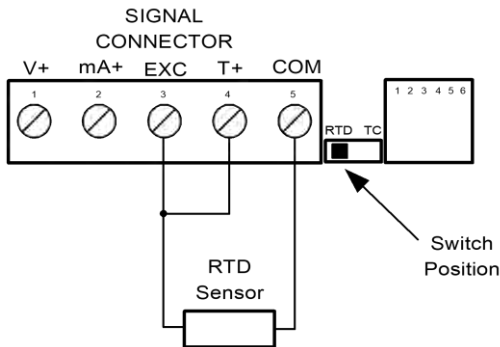

Figure 10. Two-Wire RTD Input Connections

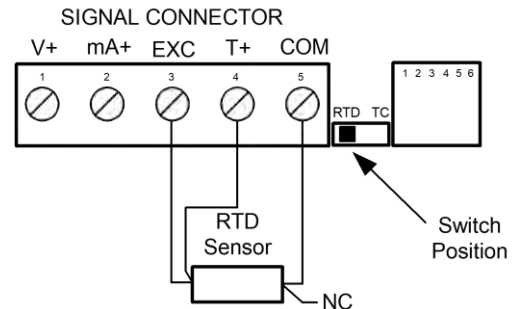

Figure 11. Four-Wire RTD Input Connections

### Serial Communication

Serial communication connection is made to an RJ11 connector labeled SERIAL on Figure 2. Use PDA7232 for RS-232 interfacing.

Use PDA7422 for RS-485 interfacing.

Use PDA7420 for meter-to-meter interfacing for cloning purposes (*i.e.* copying programmed settings from one meter to other meters).

### Relays and 24 V Output Connections

Relay connections are made to a six-terminal connector labeled RELAY1, RELAY2 on Figure 2. The COM (common) terminals of the relays should not be confused with the COM (common) terminal of the SIGNAL connector. The 24 VDC output is available at the connector labeled 24V OUT, next to the relays connector.

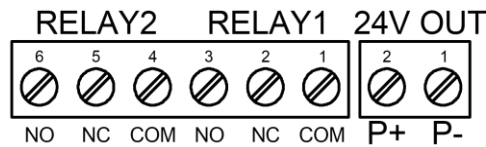

**Figure 12. Relay & 24 V Output Connections**

### Switching Inductive Loads

The use of suppressors (snubbers) is strongly recommended when switching inductive loads to prevent disrupting the microprocessor's operation. The suppressors also prolong the life of the relay contacts. Suppression can be obtained with resistor-capacitor (RC) networks assembled by the user or purchased as complete assemblies. Refer to the following circuits for RC network assembly and installation:

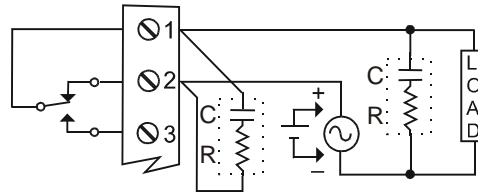

**Figure 13. AC and DC Loads Protection**

Choose R and C as follows:

R: 0.5 to 1  $\Omega$  for each volt across the contacts

C: 0.5 to 1  $\mu\text{F}$  for each amp through closed contacts

**Notes:**

1. Inductive relay rating is 1/14 HP (50 W) at 115/230 VAC
2. Use capacitors rated for 250 VAC.
3. RC networks may affect load release time of solenoid loads. Check to confirm proper operation.
4. Install the RC network at the meter's relay screw terminals. An RC network may also be installed across the load. Experiment for best results.

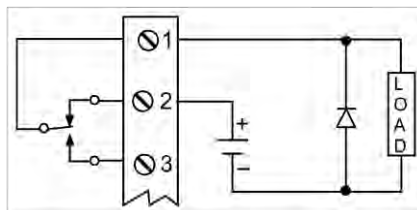

Use a diode with a reverse breakdown voltage two to three times the circuit voltage and forward current at least as large as the load current.

**Figure 14. Low Voltage DC Loads Protection**

### RC Networks Available from Precision Digital

RC networks are available from Precision Digital and should be applied to each relay contact switching an inductive load. Part number: PDX6901.

**Note:** Relays are de-rated to 1/14th HP (50 watts) with an inductive load.

### 4-20 mA Output & Input Signal Connections

Connections for the 4-20 mA transmitter output are made to the connector terminals labeled “mA OUT, I-, I+”. The 4-20 mA output may be powered from an internal power supply (optional) or from an external power supply.

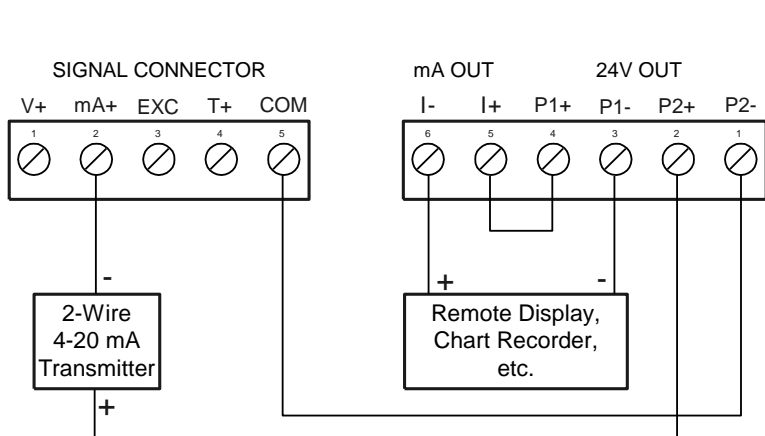

Figure 15. 4-20 mA Output & Input Signal Powered by Meter

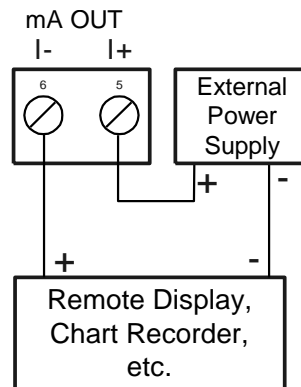

Figure 16. 4-20 mA Output Powered Externally

### External Switch Contacts

The ProtEX-MAX includes a removable screw terminal connector for external switch contacts. External switch contacts may be wired across the switch contact and COM on the connector labeled Trident X2 External Switch Connections in the Figure below.

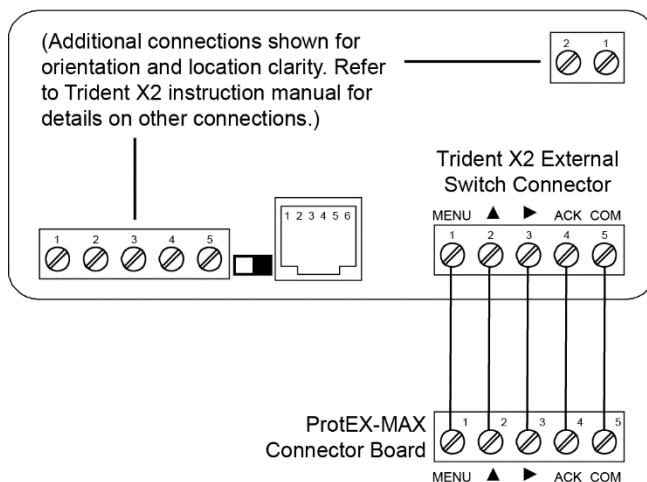

Figure 17: External Switch Contacts

**NOTICE** Removing the connectors or changing the default wiring of the ProtEX-MAX external switch connectors will affect the function of the SafeTouch buttons.

See External Switch Contacts in the Specification on page 6 for electrical specifications for using the external switch contacts.



## Setup and Programming

### Programming from a PC with MeterView®

Precision Digital's free MeterView® software allows all PD8-765 setup parameters to be programmed from a PC (requires PDC protocol selection) and to save the configuration settings to a file for reporting or programming other meters. And since the serial adapter is an external device, one serial adapter can program an infinite number of meters!



The MeterView screen shot above shows how the input is selected. Notice there are tabs for Scaling, Relays/Alarms, Advanced, and Factory Values.

- There is **no need to recalibrate** the meter when first received from the factory.
- The meter is **factory calibrated** prior to shipment, for all input types, in milliamps, volts, and degrees respectively. The calibration equipment is traceable to NIST standards.

### Overview

There are no jumpers involved in the setup process of the meter. The RTD/TC selector switch, located between the SIGNAL and SERIAL connectors, must be set accordingly for the meter to accept RTD or thermocouple inputs, Figure 2.

Setup and programming is done through the front panel buttons.

After power and signal connections have been completed and verified, apply power to the meter.

For **Quick Interface Reference Guide**  
go to page 47

## SafeTouch® Buttons

The ProtEX-MAX is equipped with four sensors that operate as through-glass buttons so that it can be programmed and operated without removing the cover (and exposing the electronics) in a hazardous area.

These buttons can be disabled for security by selecting DISABLE on the switch labeled NO-CONTACT BUTTONS located on the connector board.

To actuate a button, press one finger to the glass directly over the marked button area. Then retract finger more than three inches from the glass before pressing the next button. When the cover is removed, the four mechanical buttons located next to the sensors are used. The sensors are disabled when a mechanical button is pressed and will automatically be re-enabled after 60 seconds of inactivity.

The SafeTouch Buttons are designed to filter normal levels of ambient interference and to protect against false triggering, however, it is recommended that the SafeTouch Buttons be disabled (slide switch to LOCK) if there is an infrared interference source in line-of-sight to the display.

The SafeTouch Buttons are configured by default to duplicate the function of the front panel mechanical pushbuttons associated with the integrated meter. The symbols by each SafeTouch button correspond to a mechanical button as shown in the table on the next page.

SafeTouch Button Tips:

- To the extent possible, install the display facing away from sunlight, windows, reflective objects and any sources of infrared interference.
- Keep the glass window clean.
- Tighten the cover securely.
- Use a password to prevent tampering.



Take caution when cleaning the window glass as it may result in unintentional SafeTouch button events. Only clean the ProtEX-MAX when the system is safely shut down, and inspect the ProtEX-MAX for proper configuration prior to system restart.

### Front Buttons and Status LED Indicators



Button Symbol	Description
	Menu
	Right arrow/Reset
	Up arrow/Max
	Enter/Ack

LED	Status
1	Alarm 1
2	Alarm 2
S	Set point indicator
R	Reset point indicator

- Press the **Menu** button to enter or exit the Programming Mode at any time.
- Press the **Right** arrow button to move to the next digit during digit programming.
- Press the **Up** arrow button to scroll through the menus, decimal point, or to increment the value of a digit.
- Press the **Enter/Ack** button to access a menu or to accept a setting.
- Hold the **Menu** button for approximately 3 seconds to access the *Advanced Features Menu* of the meter.

For Interactive Virtual Meter Demo visit [tvm.predig.com](http://tvm.predig.com)

## Display Functions and Messages

The meter displays various functions and messages during setup/programming and operation. The following table shows the displayed functions and messages with their action/setting description.

Display	Parameter	Action/Setting	Display	Parameter	Action/Setting
SEtU	Setup	Enter Setup menu	R-nr	Auto-manual	Set relay for automatic + manual reset any time
inPt	Input	Enter Input menu	LtLH	Latching	Set relay for latching operation
4-20	4-20 mA	Set meter for 4-20 mA input	L-L	Latching-cleared	Set relay for latching operation with manual reset only after alarm condition has cleared
0-10	0-10 VDC	Set meter for ±10 VDC input	RLtr	Alternate	Set relays for pump alternation control
rtd	RTD	Set meter for RTD input	oFF	Off	Disable relay and front panel status LEDs Disable relay's fail-safe operation
R385	Alpha 385	Set $\alpha = 0.00385$ European curve 100 $\Omega$ RTD	SEt 1	Set 1	Program set point 1
R392	Alpha 392	Set $\alpha = 0.00392$ American curve 100 $\Omega$ RTD	rSEt 1	Reset 1	Program reset point 1
tC	TC	Set meter for TC input	rLY2	Relay 2	Setup relay 2
0 J	0 J	Type J	Rct2	Action 2	Set relay 2 action (automatic, latching, etc.)
1 K	1 K	Type K	SEt2	Set 2	Program set point 2
2 T	2 T	Type T	rSEt2	Reset 2	Program reset point 2
3 T.0	3 T.0	Type T, 0.1° resolution	FLSF	Fail-safe	Enter Fail-safe menu
4 E	4 E	Type E	FLS 1	Fail-safe1	Set relay 1 fail-safe operation
F C	°F or °C	Set temperature scale	on	On	Enable fail-safe operation
°F	°F	Set meter to Fahrenheit	oFF	Off	Disable fail-safe operation
°C	°C	Set meter to Celsius	FLS2	Fail-safe2	Set relay 2 fail-safe operation
dEcP	Decimal point	Set decimal point	dLRY	Delay	Enter Time Delay menu
PrOg	Program	Enter the Program menu	dLY 1	Delay 1	Enter relay 1 time delay setup
ScAL	Scale	Enter the Scale menu	On 1	On 1	Set relay 1 On time delay
CRl	Calibrate	Enter the Calibrate menu	oFF 1	Off 1	Set relay 1 Off time delay
inP 1	Input 1	Calibrate input 1 signal or program input 1 value	dLY2	Delay 2	Enter relay 2 time delay setup
d 1 1	Display 1	Program display 1 value	On 2	On 2	Set relay 2 On time delay
inP 2	Input 2	Calibrate input 2 signal or program input 2 value	oFF2	Off 2	Set relay 2 Off time delay
d 1 2	Display 2	Program display 2 value	brEH	Break	Set RTD/TC input break relay behavior
Err	Error	Error, calibration not successful, check signal	brH 1	Relay 1 Break	Set relay 1 input break relay behavior
rELY	Relay	Enter the Relay menu			
rLY 1	Relay 1	Relay 1 setup			
Rct 1	Action 1	Set relay 1 action (automatic, latching, etc.)			
Ruto	Automatic	Set relay for automatic reset			

Display	Parameter	Action/Setting	Display	Parameter	Action/Setting
OFF	Off	Set relay to non-alarm condition at break	out2	Output 2	Program output 2 value (e.g. 20 mA)
On	On	Set relay to alarm condition at break	SEbr	Sensor break	Program TC or RTD sensor break value for analog out
brH2	Relay 2 Break	Set relay 2 input break relay behavior	PRSS	Password	Enter the Password menu
Route	Analog output	Enter the Analog output menu	unLc	Unlocked	Program password to lock meter
ScRL	Scale	Enter the Scale menu	LoLd	Locked	Enter password to unlock meter
d.5f	Display 1	Program display 1 value	9999 - 1999	Flashing display	Overrange condition Underrange condition
out1	Output 1	Program output 1 value (e.g. 4 mA)	oPEn		Open TC or RTD sensor
d.52	Display 2	Program display 2 value			

## Main Menu

The main menu consists of the most commonly used functions: *Setup* and *Password*.

- Press **Menu** button to enter Programming Mode then press **Up** arrow button to scroll main menu.

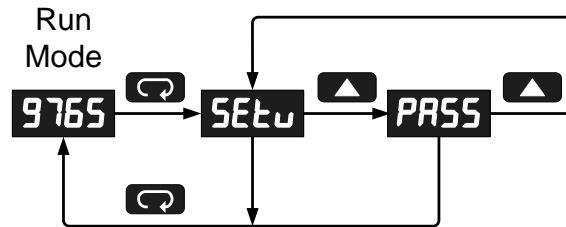

- Press **Menu**, at any time, to exit and return to Run Mode. Changes made to settings prior to pressing **Enter/Ack** are not saved.
- Changes to the settings are saved to memory only after pressing **Enter/Ack**.
- The display moves to the next menu every time a setting is accepted by pressing **Enter/Ack**.

## Setting Numeric Values

The numeric values are set using the **Right** and **Up** arrow buttons. Press **Right** arrow to select next digit and **Up** arrow to increment digit value.

The digit being changed is displayed brighter than the rest.

Press the **Enter/Ack** button, at any time, to accept a setting or **Menu** button to exit without saving changes.

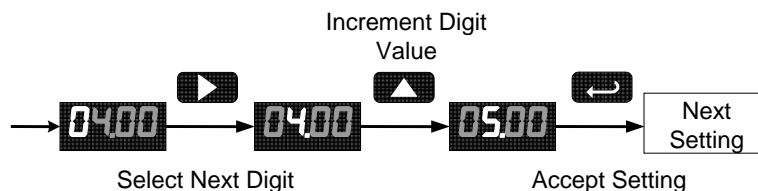

The decimal point is set using the **Up** arrow button in the *Setup-decimal point* menu.

## Setting Up the Meter (SEtU)

The *Setup* menu is used to select:

1. Input signal the meter will accept
2. Decimal point position for process inputs
3. Units (°F or °C) for temperature inputs
4. Relay operation
5. 4-20 mA analog output set up

Press the **Enter/Ack** button to access any menu or press **Up** arrow button to scroll through choices. Press the **Menu** button to exit at any time.

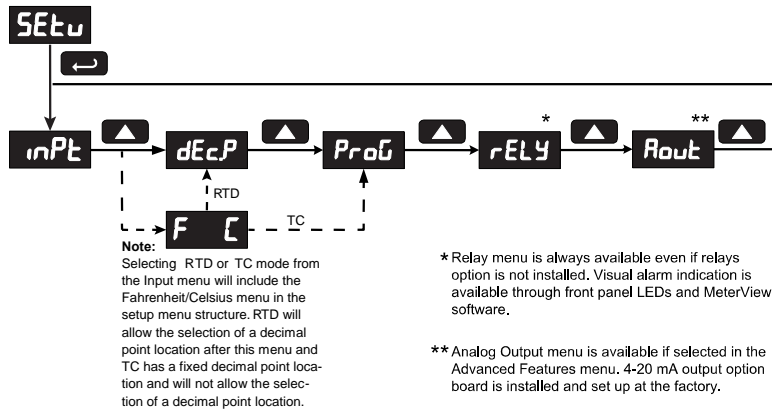

## Setting the Input Signal (inPt)

Enter the *Input* menu to set up the meter to display current (4-20), voltage (0-10), thermocouple (TC), or RTD (rtd) inputs.

The voltage input is capable of accepting any signal from -10 to +10 VDC. Select voltage input to accept 0-5, 1-5, 0-10, or ±10 VDC signals.

The current input is capable of accepting any signal from -20 to 20 mA. Select current input to accept 0-20 or 4-20 mA signals.

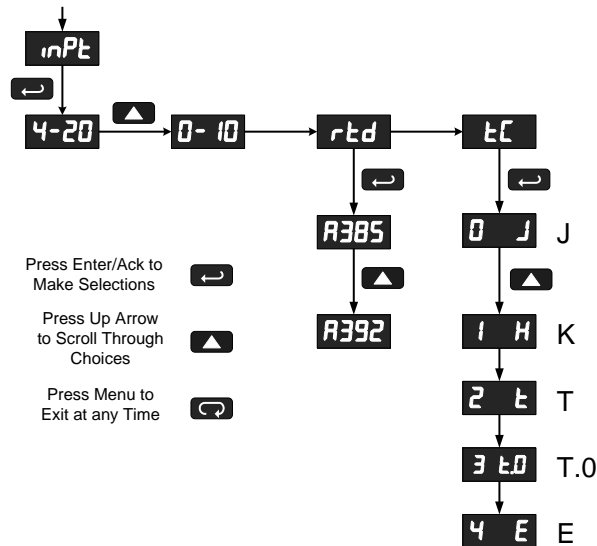

If RTD is selected, the display shows **R385** or **R392**. Select the coefficient to match the RTD sensor, either 0.00385 (**R385**, European curve) or 0.00392 (**R392**, American curve). The display then shows the decimal point menu, **dEcP**. Select the decimal point resolution as shown on page 22.

If TC is selected, scroll through the thermocouple types and select the type matching the TC sensor.

The input signal must be connected to the appropriate input terminals and the RTD/TC selector switch must be set, see Figure 8 on page 14.

***For thermocouple inputs, allow at least 30 minutes warm-up time for meter to reach specified accuracy.***

### Setting the Decimal Point (dEcP)

Decimal point for process inputs may be set with up to three decimal places or with no decimal point at all.

Decimal point for RTD inputs may be set with 1 decimal place or none.

Decimal point for thermocouple inputs is fixed.

Pressing the **Up** arrow moves the decimal point one place to the right until no decimal point is displayed, it then moves to the leftmost position.

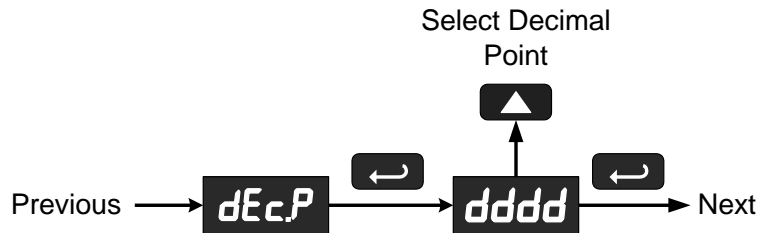

### Setting the Temperature Scale (F °C)

The meter can be set to display temperature in degrees Fahrenheit or Celsius.

Press **Up** arrow to change selection.

Press **Enter/Ack** to accept.

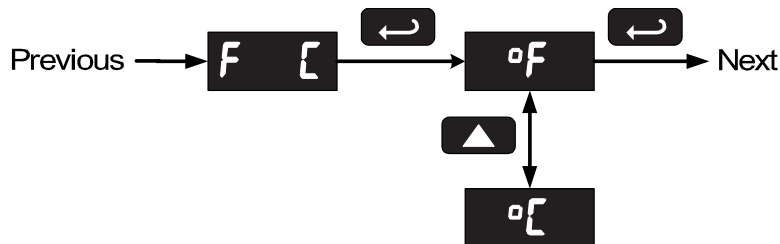

### Programming the Meter (*Prog*)

It is **very important** to read the following information, before proceeding to program the meter:

- There is **no need to recalibrate** the meter when first received from the factory.
- The meter is **factory calibrated** prior to shipment, for all input types, in milliamps, volts, and degrees respectively. The calibration equipment is traceable to NIST standards.
- Use the *Scale* menu to scale process inputs (e.g. 4-20 mA). A calibrated signal source is not needed to scale the meter.
- For thermocouple and RTDs, just connect the sensor to the proper terminals and turn the power on. **No calibration needed!** (when the meter is first received from the factory).

The *Program* menu contains the *Calibrate* and the *Scale* menus.

Process inputs may be calibrated or scaled to any display within the range of the meter.

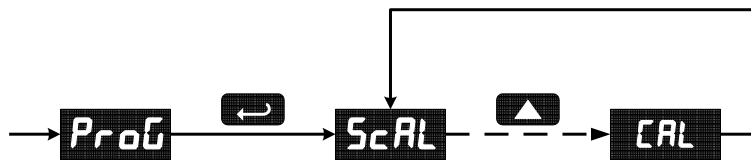

Additional parameters, not needed for most applications, are programmed with the *Advanced Features* menu, see *Advanced Features Menu*, page 33.

### Scaling the Meter (*ScAL*)

The process inputs (4-20 mA and  $\pm 10$  VDC) can be scaled to display the process in engineering units. A signal source is not needed to scale the meter; simply program the inputs and corresponding display values.

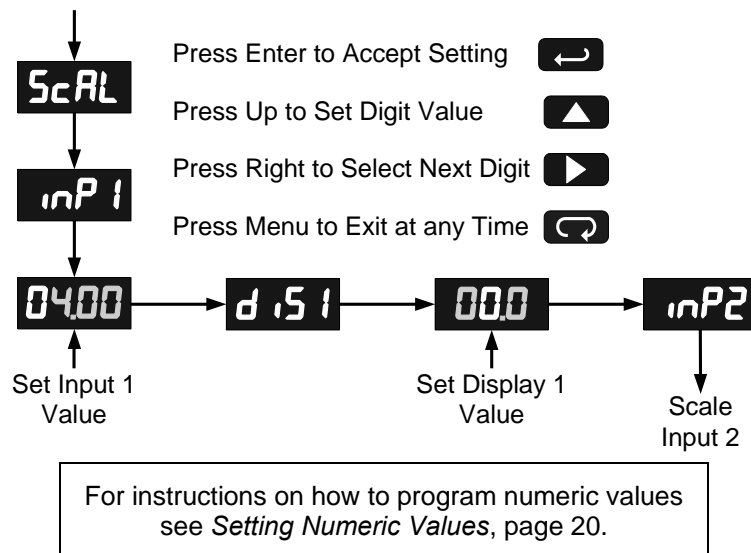

Note:

The *Scale* menu is not available for temperature inputs.

### Error Message (Err)

An error message indicates that the calibration or scaling process was not successful.

After the error message is displayed, the meter reverts to input 1, allowing the appropriate input signals to be applied.

The error message might be caused by any of the following conditions:

1. Input signal is not connected to the proper terminals or it is connected backwards.
2. Wrong signal selection in *Setup* menu.
3. Minimum input span requirements not maintained.
4. Input 1 signal inadvertently applied to calibrate input 2.

### Minimum Input Span

The minimum input span is the minimum difference between input 1 and input 2 signals required to complete the calibration or scaling of the meter.

Input range	Input 1 & input 2 span
4-20 mA	0.40 mA
±10 VDC	0.20 VDC
TC	100°F (56°C)
RTD	50°F (28°C)

### Calibrating the Meter (CAL)

To scale the meter without a signal source, refer to *Scaling the Meter (ScAL)*, page 23.

The meter can be calibrated to display the process in engineering units by applying the appropriate input signal and following the calibration procedure.

The use of a calibrated signal source is strongly recommended to calibrate the meter.

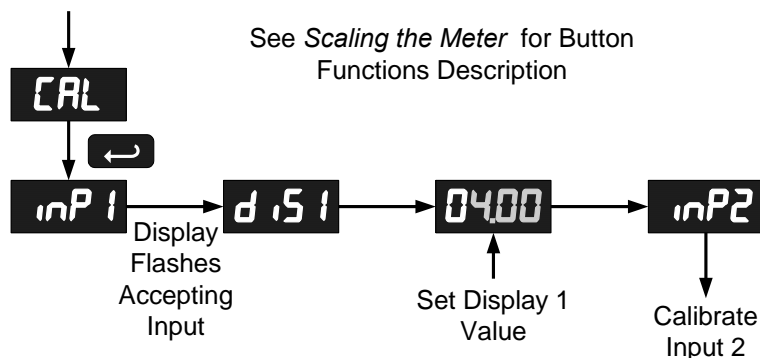

### Recalibrating Temperature Inputs (CAL)

Remember, the meter is **calibrated** at the factory prior to shipment. Recalibration is recommended at least every twelve months.

The *Calibration (CAL)* menu is used to **recalibrate** the thermocouple and RTD inputs.

**Allow at least 30 minutes warm-up time before performing recalibration procedure to ensure specified accuracy.**



### Recommended Calibration Points

To recalibrate the meter, it is recommended to use the Fahrenheit scale; this will give a greater degree of accuracy to the calibration. The scale can be changed to the Celsius scale after calibration is completed. The meter will display temperature accurately in any scale. The following table shows the recommended low and high calibration points for all types.

Type of input	Input 1 (Low)	Input 2 (High)	Check (Middle)
Type J T/C	32°F	1182°F	600°F
Type K T/C	32°F	1893°F	960°F
Type T T/C	32°F	693°F	360°F
Type T T/C	32.0°F	693.0°F	360.0°F
Type E T/C	32°F	1652°F	840°F
100 Ω RTD (0.00385)	32°F 100Ω	1148°F 320.12Ω	590°F 215.61Ω
100 Ω RTD (0.00392)	32°F 100Ω	1127°F 320.89Ω	580°F 215.87Ω

### Recalibration Procedure for Temperature Inputs

1. Connect signal to the meter using the appropriate wire (e.g. type J thermocouple wire to recalibrate type J input), see page 14.
2. Set up the meter to accept the selected input (e.g. type J T/C), see page 21.
3. Set up the meter to display temperature in degrees Fahrenheit, see page 22.
4. Apply signal corresponding to input 1 (32°F) and program display 1 to 32, see page 24.
5. Apply signal corresponding to input 2 (1182°F for type J) and program display 2 accordingly, see page 24.
6. After the meter accepts input 2, the display flashes the message  $\overline{J}$  that indicates the meter is sensing the cold junction reference. This completes the recalibration procedure for the selected input.

### Recalibrating Process Inputs ( $\overline{ICAL}$ )

The *Internal Calibration* (  $\overline{ICAL}$  ) menu, located in the Advanced features menu, is used to recalibrate the current and voltage inputs. Recalibration is recommended at least every twelve months.

Refer to Internal Calibration (ICal), page 38 for instructions.

### Setting the Relay Operation (rELY)

This menu allows you to set up the operation of the relays:

1. Relay action
  - a. Automatic reset only (non-latching)
  - b. Automatic + manual reset at any time (non-latching)
  - c. Latching (manual reset only)
  - d. Latching with Clear (manual reset only after alarm condition has cleared)
  - e. Pump alternation control (automatic reset only)
  - f. Off (relay and status LED disabled)
2. Set point
3. Reset point
4. Fail-safe operation
  - a. On (enabled)
  - b. Off (disabled)
5. Time delay
  - a. On delay (0-199 seconds)
  - b. Off delay (0-199 seconds)
6. Break Condition Behavior
  - a. Off (non-alarm condition)
  - b. On (alarm condition)

Refer to page 19 for a description of *Display Functions and Messages*

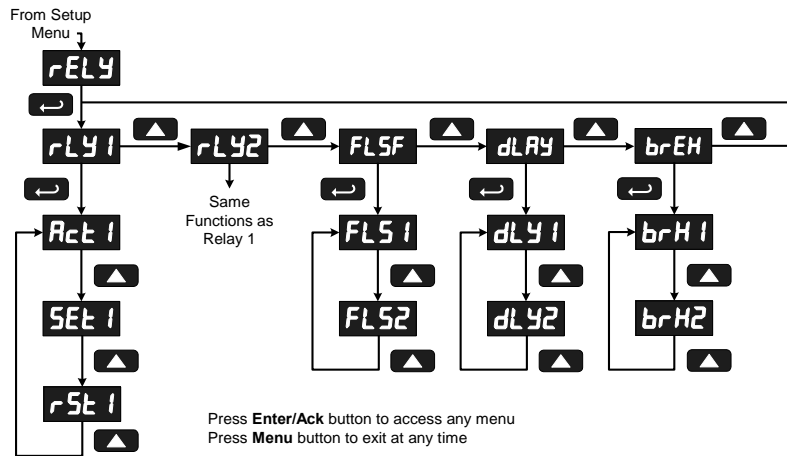

### Setting the Relay Action

The relays' *Action* menu allows the user to set up the operation of the relays. The relays may be set up for any of the following modes of operation:

1. Automatic reset (non-latching)
2. Automatic + manual reset at any time (non-latching)
3. Latching (manual reset only, at any time)
4. Latching with Clear (manual reset only after alarm condition has cleared)
5. Pump alternation control (automatic reset only)
6. Off (relay and status LED disabled)

The following graphic shows relay 1 action setup; relay 2 is set up in a similar fashion.

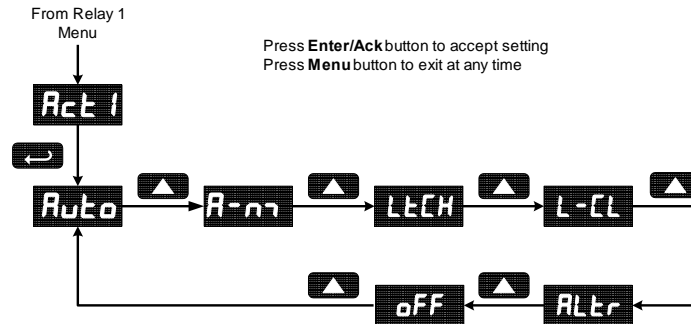

### Programming Set and Reset Points

High alarm indication: program set point above reset point.

Low alarm indication: program set point below reset point.

The deadband is determined by the difference between set and reset points. Minimum deadband is one display count. If set and reset points are programmed the same, relay will reset one count below set point.

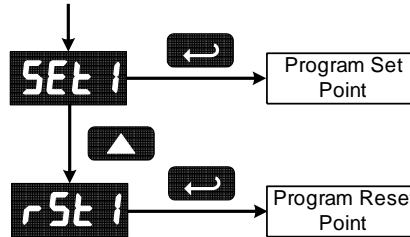

### Setting Fail-Safe Operation

The fail-safe operation is set independently for each relay. Select **on** to enable or select **off** to disable fail-safe operation.

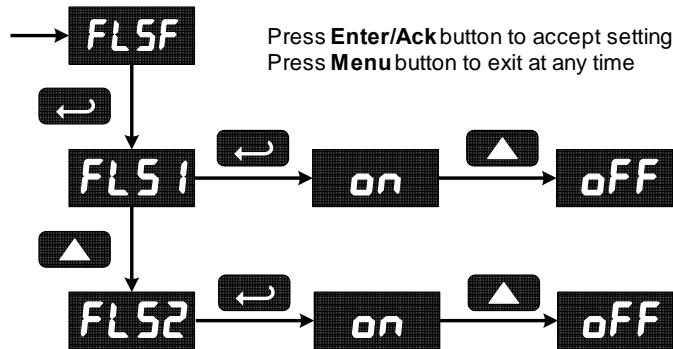

### Programming Time Delay

The *On* and *Off* time delays may be programmed for each relay between 0 and 199 seconds. The relays will transfer only after the condition has been maintained for the corresponding time delay.

The *On* time delay is associated with the set point.

The *Off* time delay is associated with the reset point.

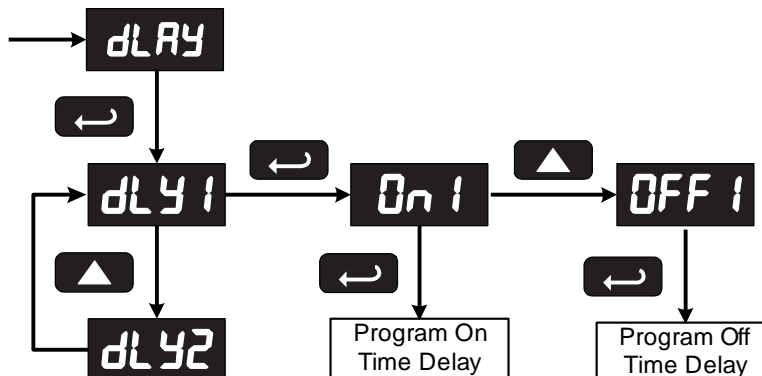

### Setting Sensor Break Condition

The sensor break relay condition may be programmed for each relay as *On* (alarm) or *Off* (non-alarm). The relays will enter these states when a sensor break is detected for RTD or thermocouple inputs. These settings have no effect when current or voltage inputs are selected.

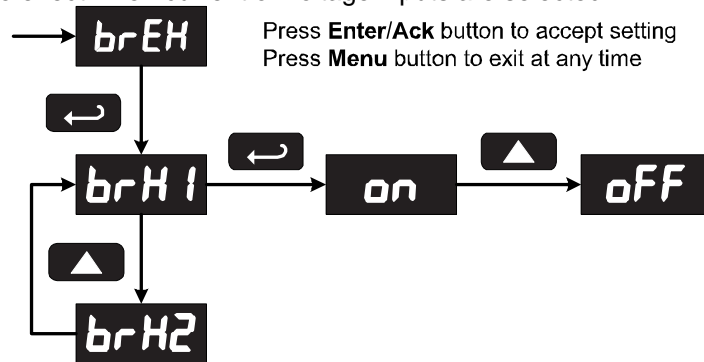

### Relay and Alarm Operation

The following graphs illustrate the operation of the relays, status LEDs, and ACK button.

#### High Alarm Operation (Set > Reset)

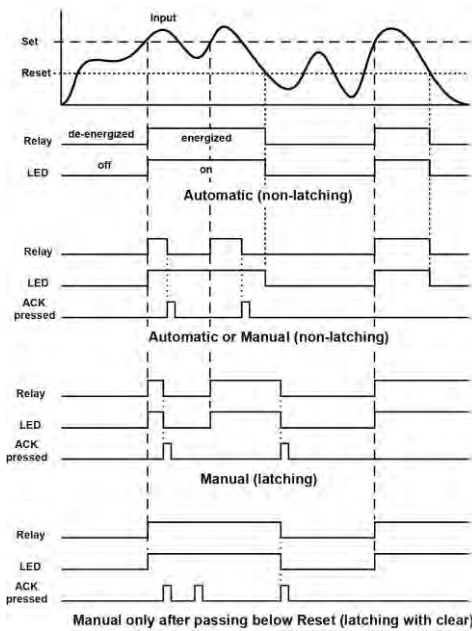

#### Low Alarm Operation (Set < Reset)

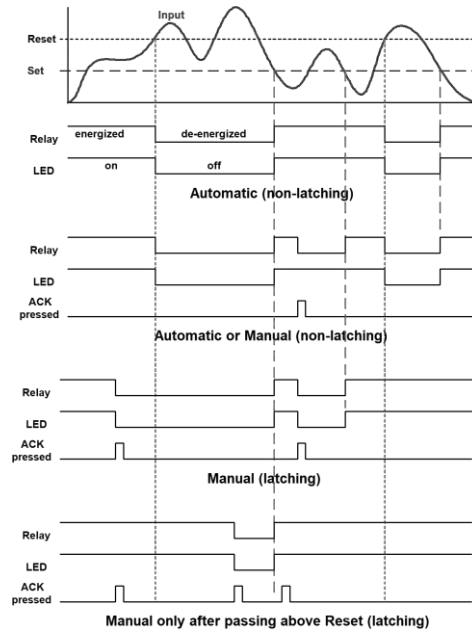

For Manual reset mode, ACK can be pressed anytime to turn "off" relay. To detect a new alarm condition, the signal must go below the set point, and then go above it.

### Time Delay Operation

The following graphs show the operation of the time delay function.

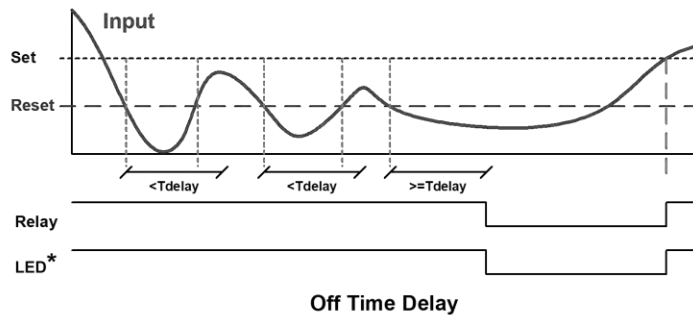
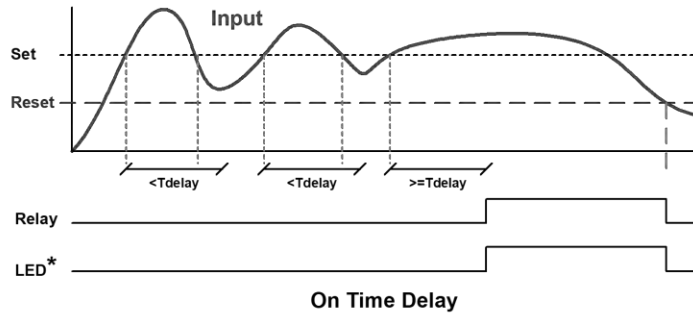

If the signal crosses the set point, the *On* time delay timer starts and the relay trips when the time delay has elapsed. If the signal drops below the set point (high alarm) before the time delay has elapsed, the *On* time delay timer resets and the relay does not change state. The same principle applies to the *Off* time delay.

\* **Note:** The LED is not affected by Time Delay when “*Automatic or Manual*” reset mode is selected. Rather the LED follows the set and reset points.

### High Alarm with Fail-Safe Operation (Set > Reset)

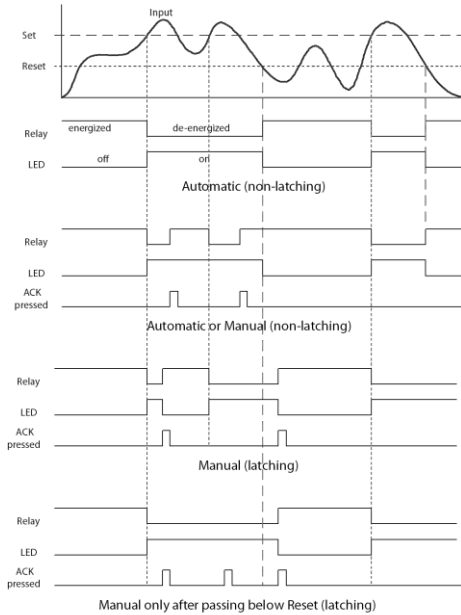

### Low Alarm with Fail-Safe Operation (Set < Reset)

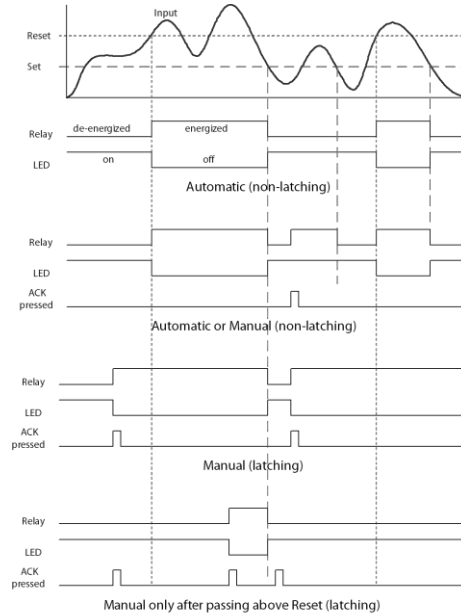

*Note: Relay coil is energized in non-alarm condition. In case of power failure, relay will go to alarm state.*

### Pump Alternation Control Operation

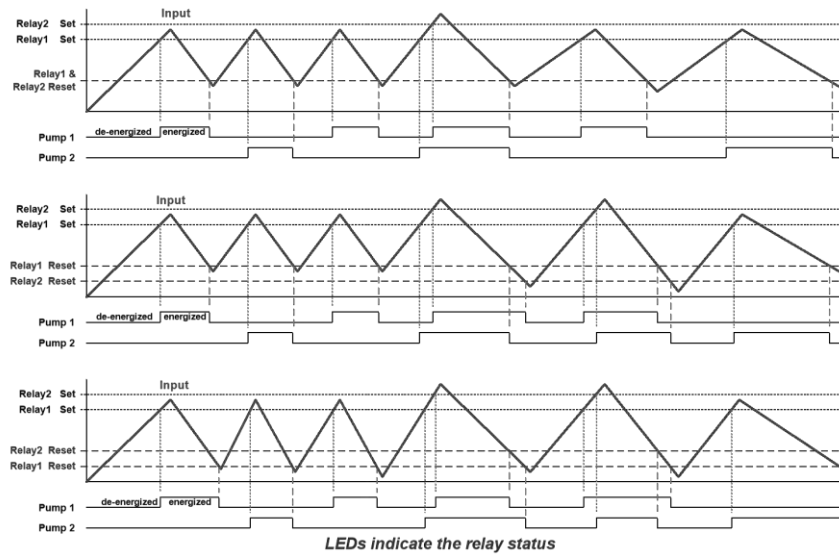

### Scaling the 4-20 mA Analog Output (Rout)

The 4-20 mA analog output can be scaled to provide a 4-20 mA signal for any display range selected. No equipment is needed to scale the analog output; simply program the display values to the corresponding mA output signal.

Depending on the version of meter purchased, the *Analog Output* menu may not appear in the *Setup* menu. This menu is enabled or disabled at the factory via the *Advanced Features* menu. For more information on the *Advanced Features* Menu see page 33.

The *Analog Output* menu is used to program:

1. 4-20 mA output based on display values
2. Sensor break value in mA

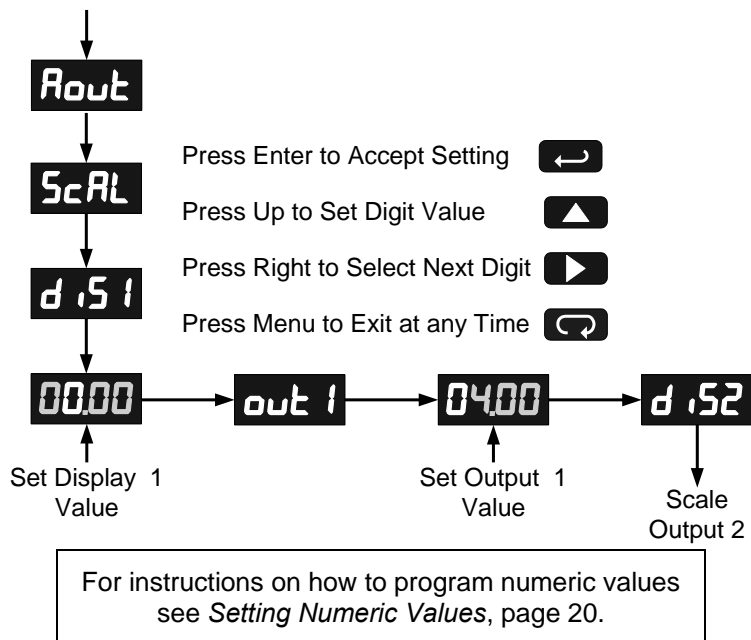

### Program the Sensor Break Output Value (SEbr)

The sensor break value corresponds to the output signal generated when the meter detects a sensor break for thermocouple and RTD inputs.

For example, if there is an open thermocouple, the meter displays the message “oPEr” and the analog output goes to the programmed sensor break value (e.g. 3.00 mA).

The sensor break value can be programmed from 0.00 to 23.99.

The typical output signal range is 1.00 to 23.00 mA (e.g. If sensor break value is programmed to 0.00, the actual output will not be greater than 1.00 mA).

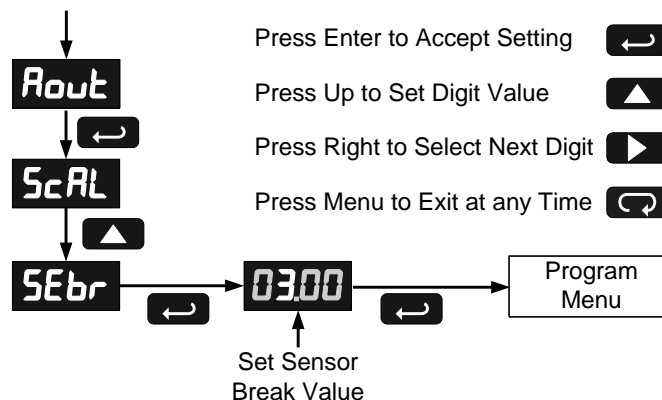

### Analog Output when Display is Out of Range

The analog output reflects the display out of range conditions as follows:

Input Condition	Display	Analog Output
Underrange	Flashing - 1999	3.00 mA
Overrange	Flashing 9999	21.00 mA
Open TC or RTD	Flashing $\sigma P E n$	Sensor break value

### Setting Up the Password (PASS)

The *Password* menu is used to program a four-digit password to prevent unauthorized changes to the programmed parameter settings.

#### Locking the Meter

Enter the *Password* menu and program a four-digit password.

For instructions on how to program numeric values see Setting Numeric Values, page 20.

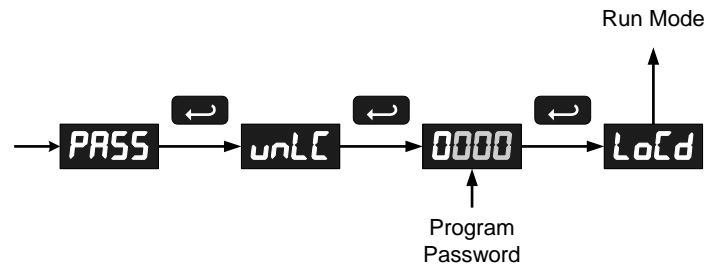

#### Unlocking the Meter

If the meter is password protected, the correct password must be entered in order to make changes to the parameter settings.

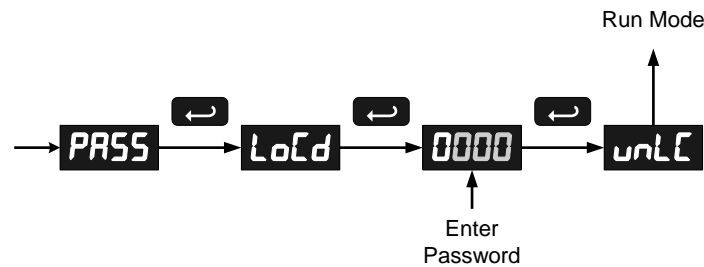

Entering the correct four-digit number sets the password to 0000, disabling the protection.

Changes to the programmed parameter settings are allowed only with the password set to 0000.

If the password entered is incorrect, the meter displays *LoCd* (Locked) for about two seconds, then it returns to Run Mode. To try again, press **Enter/Ack** while the *Locked* message is displayed.

#### Forgot the Password?

The password may be disabled by the following procedure:

1. Note display reading prior to pressing the Menu button. Ignore decimal point and sign.
2. Access the *Password* menu, add 2 to the noted reading and enter that number as the password (e.g. display reading = -1.23, password = 0125).



## Advanced Features Menu

To simplify the setup process, functions not needed for most applications are located in the *Advanced Features* menu.

Hold the **Menu** button for **approximately 3 seconds** to access the Advanced Features Menu of the meter.

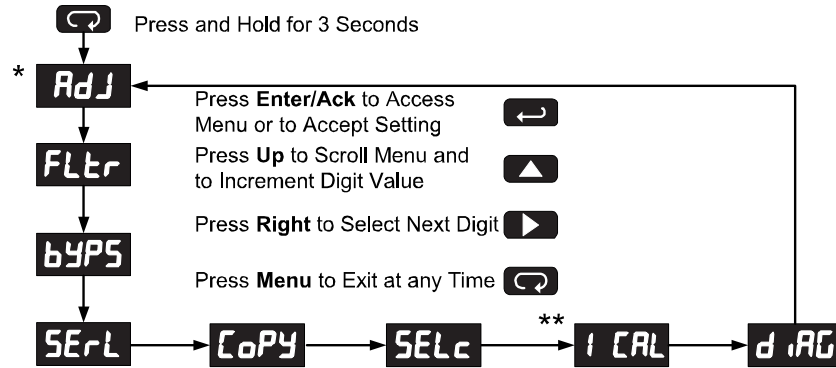

\* Available for temperature inputs only

\*\* Available for process inputs only

### Advanced Features Menu & Display Messages

Display	Parameter	Action/Setting
Adj	Adjust	Set offset adjustment for temperature, not available for process inputs
FLtEr	Filter	Set noise filter value
bYP5	Bypass	Set filter bypass value
SErL	Serial	Set serial communication parameters
PrOt	Protocol	Enter the Protocol menu
PdC	PDC	Select PDC protocol
mOb5	Modbus	Select Modbus protocol
AdDr	Address	Set meter address
bRud	Baud rate	Select baud rate
tRdE	Transmit delay	Set transmit delay for serial communication
PrEtY	Parity	Select none, even, or odd (Modbus only)
tBYt	Byte-to-byte	Program byte-to-byte timeout (silent time – Modbus only)
CoPY	Copy	Enter copy function
SEnd	Send	Send meter settings to another meter
donE	Done	Copy function completed
SELC	Select	Enter the Select menu (function, cutoff, out)
Func	Function	Select linear or square root function

Display	Parameter	Action/Setting
Linr	Linear	Set meter for linear function
SqrE	Square root	Set meter for square root extraction
cutF	Cutoff	Set low-flow cutoff
out	Output	Set meter for either relay or analog output <b>(factory set only – only included in certain models)</b>
Rout	Analog output	Set meter for analog output option
rELY	Relay	Set meter for relay option
Rout	Analog output	Enable or disable analog output <b>(factory set only – only included in certain models)</b>
YES	Yes	Enable analog output
no	No	Disable analog output
IntY	Intensity	Select display intensity
iCAL	Initial calibration	Enter initial calibration for process inputs
Cur	Current	Calibrating current input
lLo	l low	Calibrate low current input
lHi	l high	Calibrate high current input
volt	Volt	Calibrating voltage input
lLo	V low	Calibrate low voltage input

Display	Parameter	Action/Setting
VHIGH	V high	Calibrate high voltage input
DiAG	Diagnostics	Display parameter settings
LEd	LED	Test display
CJC	CJC	Display cold junction compensation voltage
CFG	CFG	Display meter configuration
PTS	Points	Display calibration points for process inputs

Display	Parameter	Action/Setting
RELAY	Relays	Display relay settings
ANALOG	Analog output	Display analog output settings
GAIN	Gain/offset	Display gain and offset for process inputs
SERIAL	Serial	Display serial communication settings
INFO	Information	Display software version and S/N information

### Offset Adjustment (Adj)

This parameter allows the user to select an offset adjustment to the temperature being displayed. Offset adjustment values can be either positive or negative and can be any number within  $\pm 19.9^\circ$ . The offset adjustment value is programmed through the *Adjust* menu.

The offset adjustment feature can be useful to compensate for errors due to thermocouple junctions or excessive lead wire resistance in RTDs.

The offset adjustment value is automatically reset to zero whenever the type of temperature sensor is changed (*i.e.* Thermocouple type or RTD curve).

Celsius/Fahrenheit conversion of the offset adjustment value is automatic, see note 2 below for important limitations.

Notes:

1. Offset adjustment is available only when TC or RTD input is selected.
2. If adjustment value is greater than  $11^\circ\text{C}$  and the temperature scale is changed to Fahrenheit, the maximum applied adjustment will be  $19.9^\circ\text{F}$ .

### Noise Filter (FLtr)

Most applications do not require changing this parameter. It is intended to help attain a steady display with an unsteady (noisy) input signal.

The field selectable noise filter averages any minor or quick changes in the input signal and displays the reading with greater stability.

Increasing the filter value will help stabilize the display, however this will reduce the display response to changes on the input signal.

The filter level may be set anywhere from 2 to 199.

Setting filter value to zero disables filter function, and bypass setting becomes irrelevant.

### Noise Filter Bypass (bYP5)

The meter can be programmed to filter small input changes, but allow larger input changes to be displayed immediately, by setting the bypass value accordingly.

If the input signal goes beyond the bypass value, it will be displayed immediately with no averaging done on it.

The noise filter bypass value may be set anywhere from 0.2 to 99.9. It corresponds to percentage of full scale for process inputs and to degrees Fahrenheit for temperature inputs.

Increasing the bypass value may slow down the display response to changes on the input signal.

### Serial Communications (SErL)

The meter is equipped with serial communications capability as a standard feature using PDC Serial Communication Protocol. The Modbus RTU protocol is included on all models after 5/1/2010. To communicate with a computer or other data terminal equipment, an RS-232 or RS-485 adapter option is required; see *Ordering Information* on page 3 for details.

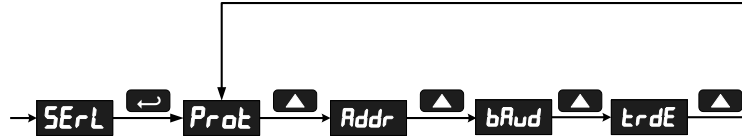

When using more than one meter in a multi-drop mode, each meter must be provided with its own unique address. The address may be programmed from 00 to 99 for PDC protocol and from 1 to 247 for Modbus protocol. The transmit delay may be set between 0 and 199 ms (see Serial Communication Adapter manual for more details).

The Trident can also be connected directly to another Trident meter through a cable assembly (PDA7420). This allows the user to copy all the settings from one meter to another, using the *Copy* function.

### Protocol Selection Menu (Prot)

The Protocol selection menu is used to select either the PDC or the Modbus protocol.

### Select Menu (SELc)

The *Select* menu is used to select linear or square root function, display intensity, and low-flow cutoff. Selection for relay or analog output is a factory setting depending on the option installed.

- Output options are installed and set up at the factory.
- Changing the output selection will cause erroneous operation.

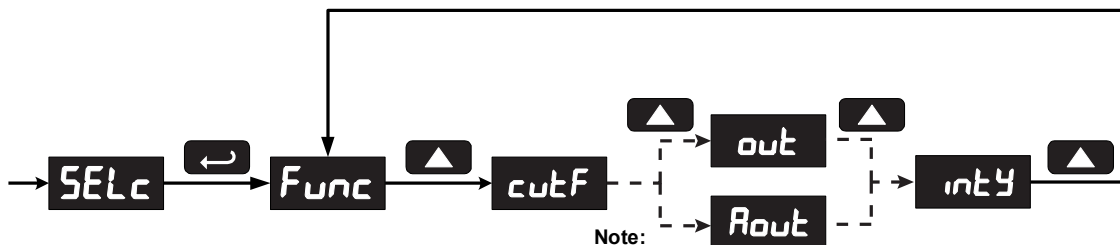

**Note:**  
Depending on meter model, the *Select* menu will display either *out* or *Aout*. In either case, the output selection menu is for factory use only. Do not attempt to change output selection.

### Linear or Square Root Function (L inr or SqrE)

Meters are set up at the factory for linear function. The linear function provides a display that is linear with respect to the input signal.

The square root function is used to linearize the signal from a differential pressure transmitter and display flow rate in engineering units.

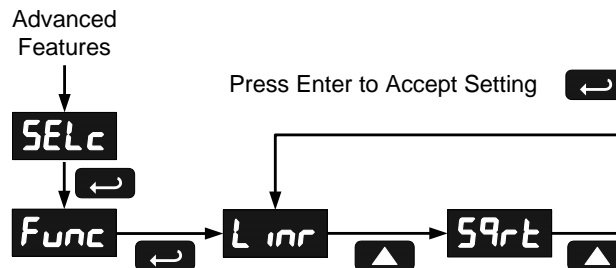

### Low-Flow Cutoff (cutF)

The low-flow cutoff feature allows the meter to be programmed so that the often-unsteady output from a differential pressure transmitter, at low flow rates, always displays zero on the meter.

The cutoff value may be programmed from 0 to 9999. Below the cutoff value, the meter will display zero. Programming the cutoff value to zero disables the cutoff.

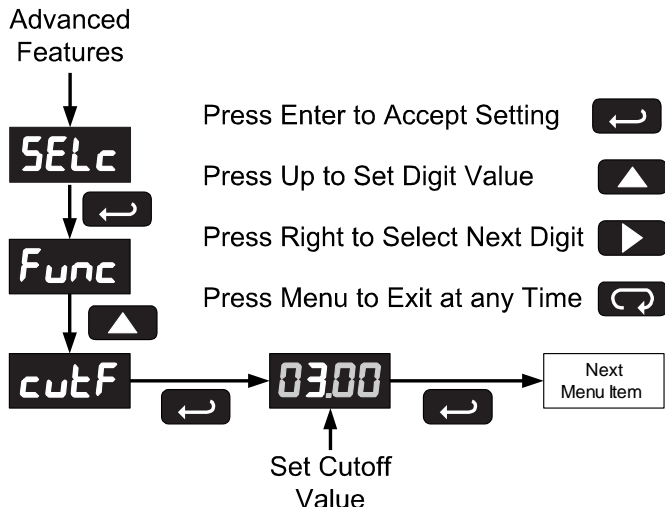

### Display Intensity (intY)

The Display Intensity function allows the selection of eight levels of intensity for various lighting conditions.

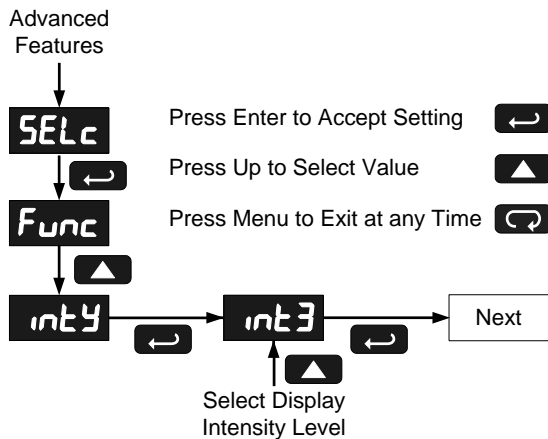

### MeterView® Software

Precision Digital's MeterView® software allows the Trident to be programmed from a PC and to act as a data logger.

MeterView® software allows all setup parameters to be saved to a file for reporting, restoring, or programming other meters.

See *Ordering Information*, page 3 to order MeterView® software.

*Note: PDC protocol must be selected to communicate with MeterView®.*

### Meter Copy Function (COPY)

The Copy function is used to copy (or clone) all the settings from one meter to other meters requiring exactly the same setup and programming (i.e. type of input, scaling, decimal point, filter, bypass, etc.).

#### COPY Function Requirements

To successfully copy settings from one meter to another, both meters must have:

1. Same software version
2. Same baud rate setting
3. PDC protocol selected

See *Determining Software Version*, page 42 for instructions.

### Meter Cloning Instructions

**NOTICE!** Do not connect the two meters to the same 4-20 mA loop while cloning. Internal calibration may be affected.

1. Connect the two meters using cable assembly PDA7420 or equivalent (e.g. Digi-Key P/N H1663-07-ND). Cable should not exceed 7' (2.1 m).
2. Power up both meters. Leave Clone meter in Run Mode.
3. Enter the *Advanced Features Menu* of the Master meter, see *Advanced Features Menu*, page 33.
4. Scroll to Copy function using **Up** arrow button then press **Enter/Ack**.
5. The meter displays the message `SEnd`. Press **Enter/Ack**, the display flashes while sending data. The message `donE` is displayed when copying is completed.

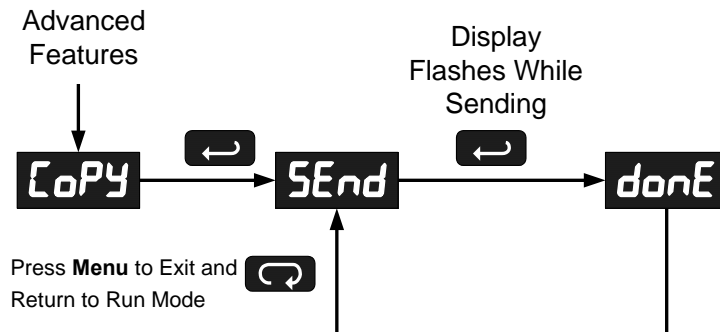

6. The Clone meter displays the memory address being programmed then the message `donE` when copying is completed. The meter initializes and returns to Run Mode using the same settings as the Master.
7. If meter to be cloned does not respond to the data being sent, refer to **COPY Function Requirements** above.

### Internal Calibration (ICAL)

- There is **no need to recalibrate** the meter when first received from the factory.
- The meter is **factory calibrated** prior to shipment, for all input types, in milliamps, volts, and degrees respectively. The calibration equipment is traceable to NIST standards.
- 

The internal calibration allows the user to scale the meter without applying a signal. This menu is not available if the meter is set up for TC or RTD inputs.

The use of calibrated signal sources is necessary to perform the internal calibration of the meter.

Check calibration of the meter at least every 12 months. Each input type must be recalibrated separately, if meter will be used with all input types.

Notes:

- If meter is in operation and it is intended to accept only one input type (e.g. 4-20 mA), recalibration of other inputs is not necessary.
- Allow the meter to warm up for at least 15 minutes before performing the internal calibration procedure.

The *Internal calibration* menu is part of the *Advanced Features Menu*.

1. Hold the Menu button **for** approximately 3 seconds **to** access the Advanced Features Menu of the meter. Press the **Up** arrow button to scroll to the *Internal calibration* menu and press **Enter/Ack**.
2. The meter displays either current (Curr) or voltage (VOLT), according to the meter input setup. Press **Enter/Ack** to start the calibration process.

**Example for current input internal calibration:**

3. The meter displays *Low* input current (I Lo). Apply the low input signal and press **Enter/Ack**. The display flashes for a moment while meter is accepting the low input.
4. After the display stops flashing, a number is displayed with the leftmost digit brighter than the rest. The bright digit is the active digit that can be changed by pressing the **Up** arrow button. Press the **Right** arrow button to move to the next digit.
5. Set the display value to correspond to the input signal being calibrated.
6. The display moves to the high input calibration (I Hi). Apply the high input signal and press **Enter/Ack**.
7. Set the display for the high input calibration in the same way as it was set for the low input calibration.

For instructions on how to program numeric values see Setting Numeric Values, page 20.

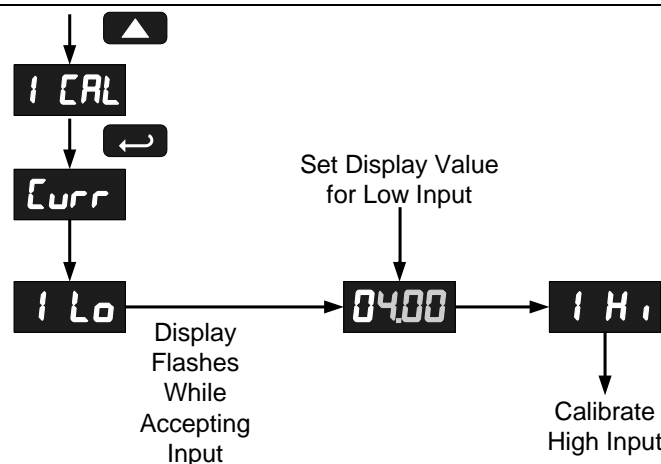

The graphic above shows the calibration of the current input. The voltage input is calibrated in a similar way.

**Tips:**

- Low and high input signals can be any valid values within the range of the meter.
- Observe minimum input span requirements between input 1 and input 2.
- Low input must be less than high input signal.

**Error Message (Err)**

An error message indicates that the calibration or scaling process was not successful.

After the error message is displayed, the meter reverts to input 1, allowing the appropriate input signals to be applied.

The error message might be caused by any of the following conditions:

1. Input signal is not connected to the proper terminals, or it is connected backwards.
2. Wrong signal selection in *Setup* menu.
3. Minimum input span requirements not maintained.

**Minimum Input Span**

The minimum input span is the minimum difference between input 1 and input 2 signals required to complete the calibration or scaling of the meter.

Input range	Input 1 & input 2 span
4-20 mA	0.40 mA
±10 VDC	0.20 VDC
TC	100°F (56°C)
RTD	50°F (28°C)





Input range	Input 1 & input 2 span
4-20 mA	0.40 mA
±10 VDC	0.20 VDC

## Operation

For process inputs, the meter is capable of accepting positive and negative signals and displaying these signals in engineering units from -1999 to 9999 (e.g. a signal from -10 to +10 VDC could be displayed as -10.00 to 10.00).

The temperature inputs are displayed according to the input type and temperature units (°F or °C) selected. RTD and Type T thermocouple inputs can be displayed with either 1° or 0.1° resolution.

### Front Buttons Operation

Button Symbol	Description
	Press to enter or exit Programming Mode, view settings, or exit Max/Min readings Hold to enter <i>Advanced</i> features menu.
	Press to reset Max/Min readings
	Press to display Max/Min readings alternately
	Press to display Max/Min reading indefinitely while displaying Max/Min Press ACK to acknowledge relays

### SafeTouch® Buttons

The ProtEX-MAX is equipped with four sensors that operate as through-glass buttons so that it can be programmed and operated without removing the cover (and exposing the electronics) in a hazardous area.

These buttons can be disabled for security by selecting DISABLE on the switch labeled NO-CONTACT BUTTONS located on the connector board.

To actuate a button, press one finger to the glass directly over the marked button area. Then retract finger more than three inches from the glass before pressing the next button. When the cover is removed, the four mechanical buttons located next to the sensors are used. The sensors are disabled when a mechanical button is pressed and will automatically be re-enabled after 60 seconds of inactivity.

The SafeTouch Buttons are designed to filter normal levels of ambient interference and to protect against false triggering, however, it is recommended that the SafeTouch Buttons be disabled (slide switch to LOCK) if there is an infrared interference source in line-of-sight to the display.

The SafeTouch Buttons are configured by default to duplicate the function of the front panel mechanical pushbuttons associated with the integrated meter. The symbols by each SafeTouch button correspond to a mechanical button as shown in the table on the next page.

#### SafeTouch Button Tips:

- To the extent possible, install the display facing away from sunlight, windows, reflective objects and any sources of infrared interference.
- Keep the glass window clean.
- Tighten the cover securely.
- Use a password to prevent tampering.



**WARNING**

Take caution when cleaning the window glass as it may result in unintentional SafeTouch button events. Only clean the ProtEX-MAX when the system is safely shut down, and inspect the ProtEX-MAX for proper configuration prior to system restart.



## Maximum/Minimum Readings

The main function of the front panel buttons during operation is to display the maximum and minimum readings reached by the process or temperature inputs.

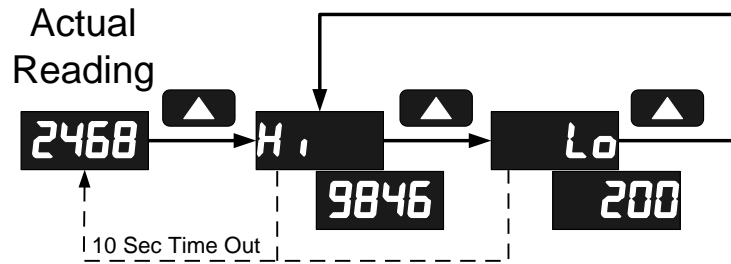

Press **Up** to Display and to Toggle Between Max & Min 

Press **Enter** to Hold Max/Min 

Press **Right** to Reset Max/Min 

Press **Menu** to Exit Max/Min 

1. Press **Up** arrow/**Max** button to display maximum reading since the last reset/power-up.
2. Press **Up** arrow/**Max** again to display the minimum reading since the last reset/power-up.
3. Press **Enter/Ack** to hold Max/Min display reading, the meter will continue to track new Max/Min readings.
4. If **Enter/Ack** is not pressed, the Max/Min display reading will time out after ten seconds and the meter will return to display the actual reading.
5. Press **Right** arrow/**Reset** button to reset Max/Min while reading is being displayed. Max/Min display readings are reset to actual reading.

## Service



### WARNINGS

- Installation and service should be performed only by trained service personnel. Service requiring replacement of internal sub-components must be performed at the factory.
- Disconnect from supply before opening enclosure. Keep cover tight while circuits are alive. Conduit seals must be installed within 18" (450mm) of the enclosure.
- Verify that the operating atmosphere of the instrument is consistent with the appropriate hazardous locations certifications.
- If the instrument is installed in a high voltage environment and a fault or installation error occurs, high voltage may be present on any lead
- Read all product labels completely and follow all instructions and requirements listed on the labels for installation or service.

If the enclosure is sound and undamaged, then only the internal electronics housing will need to be returned to the factory for service. Contact the factory for RMA number and return instructions.

## Mounting Dimensions

All units: inches (mm)

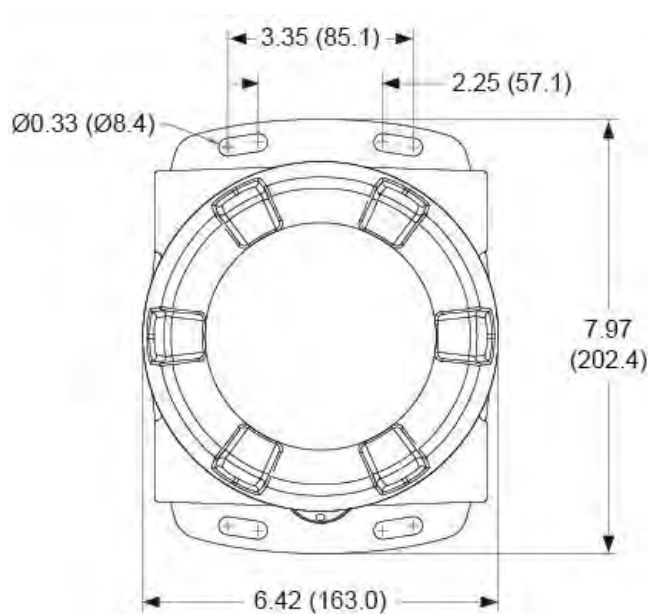

Figure 18: Enclosure Dimensions – Front View

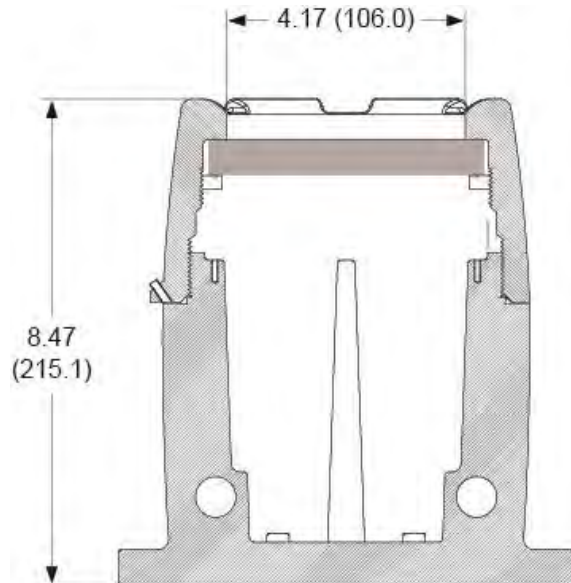

Figure 19: Enclosure Dimensions – Side Cross Section View

## Troubleshooting

For an *Interactive Virtual Meter Demo* visit [tvm.predig.com](http://tvm.predig.com)

Due to the many features and functions of the meter, it's possible that the setup of the meter does not agree with what an operator expects to see. If the meter is not working as expected, refer to the *Diagnostics* menu and consult the recommendations described below.

### Diagnostics Menu (*d* *RL*)

The *Diagnostics* menu is located in the *Advanced Features Menu*, to access *Diagnostics* menu see *Advanced Features Menu*, page 33.

It provides an easy way to view the programmed parameter settings for troubleshooting purposes. Press the **Enter/Ack** button to view the settings and the **Menu** button to exit at any time.

For a description of the diagnostics messages see *Advanced Features Menu & Display Messages*, page 33.

### Determining Software Version

To determine the software version of a meter:

1. Go to the *Diagnostics* menu (*d* *RL*) and press **Enter/Ack** button.
2. Press **Up** arrow/**Max** button and scroll to Information menu (*inFd*).
3. Press **Enter/Ack** to access the software number (*SFE*), version (*UER*). Write down the information as it is displayed. Continue pressing **Enter/Ack** until all the information is displayed.

## Reset Meter to Factory Defaults

When the parameters have been changed in a way that is difficult to determine what's happening, it might be better to start the setup process from the factory defaults.

### Instructions to load factory defaults:

1. Enter the *Advanced Features Menu*. See *Advanced Features Menu*, page 33.
2. Press **Up** arrow to go to *Diagnostics* menu
3. Press and hold **Right** arrow/Reset for five seconds, press **Enter/Ack** when display flashes *rSEt*.  
Note: If **Enter/Ack** is not pressed within three seconds, display returns to *Diagnostics* menu.
4. The meter goes through an initialization sequence (same as on power-up), and loads the factory default settings.

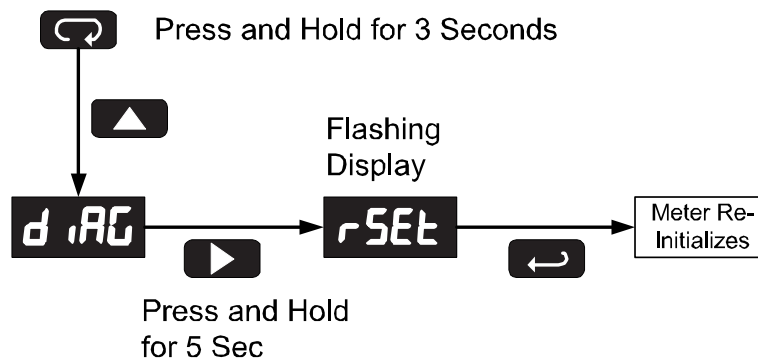

## Factory Defaults & User Settings

The following table shows the factory setting for most of the programmable parameters on the meter. MeterView® software allows the saving of all meter parameters to a file for restoring meter settings, reporting, and copying settings to other meters.

Parameter	Display	Default Setting	Parameter	Display	Default Setting
Input type	<b>inPt</b>	4-20 mA	Off delay 2	<b>OFF2</b>	0 sec
Decimal point	<b>dddd</b>	2 places	Break 1	<b>brH1</b>	Off
Programming	<b>Prog</b>		Break 2	<b>brH2</b>	Off
Input 1	<b>inP1</b>	4.00 mA	Password	<b>PASS</b>	0000 (unlocked)
Display 1	<b>d1S1</b>	4.00	Advanced Features	N/A	
Input 2	<b>inP2</b>	20.00 mA	Adjust	<b>Adj</b>	0.0° (temp only)
Display 2	<b>d1S2</b>	20.00	Filter	<b>FLtr</b>	10
Relay 1	<b>rLY1</b>		Bypass	<b>bYPS</b>	0.2
Action 1	<b>Act1</b>	Automatic	Serial settings	<b>SErL</b>	
Set 1	<b>SEt1</b>	7.00	Protocol	<b>PdL</b>	PDC protocol
Reset 1	<b>rSt1</b>	6.00	Address	<b>Rddr</b>	00
Relay 2	<b>rLY2</b>		Baud rate	<b>bAud</b>	2400
Action 2	<b>Act2</b>	Automatic	Trans delay	<b>trdE</b>	10 ms
Set 2	<b>SEt2</b>	10.00	Function	<b>Func</b>	Linear
Reset 2	<b>rSt2</b>	9.00	Cutoff value	<b>CutF</b>	0.00 (disabled)
Fail-safe	<b>FLSF</b>		Output option	<b>out/Rout</b>	Factory set only
Fail-safe 1	<b>FLS1</b>	Off	Display intensity	<b>intY</b>	Level 8
Fail-safe 2	<b>FLS2</b>	Off	Modbus defaults	N/A	
Time delay	<b>dLAY</b>		Address	<b>Rddr</b>	247
On delay 1	<b>On1</b>	0 sec	Parity	<b>Prty</b>	Even
Off delay 1	<b>OFF1</b>	0 sec	Byte-to-byte timeout*	<b>tbyt</b>	0.01 sec
On delay 2	<b>On2</b>	0 sec			

**\*Note:**

The byte-to-byte timeout setting might be updated automatically depending on the baud rate selected and the previous timeout setting. The minimum timeout allowed is saved to memory if a lower value is entered (e.g. If user enters 0.00 with a baud rate of 300, 0.06 is saved).

## Troubleshooting Tips

Symptom	Check/Action
SafeTouch buttons do not respond	<p>If mechanical button was pushed. The SafeTouch buttons will be re-enabled automatically <b>60 seconds</b> after the last button push.</p> <p>If slide switch on connector board is in DISABLE position, switch to ENABLE.</p> <p>Strong direct sunlight may interfere with SafeTouch button operation. It is recommended to operate the buttons by standing so as to block direct sunlight.</p>
Serial Communications Power LED Indicator is off	<ol style="list-style-type: none"> <li>1. Check modular cable connection</li> <li>2. Check power to the device</li> </ol>
If only the TX (or DATA IN) data status LED is flashing when serial communications attempted	<ol style="list-style-type: none"> <li>3. Check serial cable</li> <li>4. Check protocol selected on device</li> <li>5. Check instrument address &amp; baud rate</li> <li>6. Check program address &amp; baud rate</li> </ol>
If both data status LEDs (TX and RX) are off when trying to communicate	Remove all unnecessary cables and instruments from the bus. Try getting the system to work with only one device (to ease troubleshooting) and then expand the system one device at a time.
Communications slow	Increase the baud rate
Random communication errors	<ol style="list-style-type: none"> <li>1. Increase the TX delay time</li> <li>2. Decrease the baud rate</li> </ol>
Power LED is off	<ol style="list-style-type: none"> <li>3. Check modular cable connection</li> <li>4. Check power to instrument</li> </ol>
No display at all	Check power at power connector
Not able to change setup or programming, <b>LoLd</b> is displayed	Meter is locked, enter correct four-digit password to unlock
Meter displays error message during calibration ( <b>Err</b> )	Check: <ol style="list-style-type: none"> <li>1. Signal connections</li> <li>2. Input selected in <i>Setup</i> menu</li> <li>3. Minimum input span requirements</li> </ol>
Meter displays <ul style="list-style-type: none"> <li>• <b>oPEr</b></li> <li>• <b>9999</b></li> <li>• <b>- 1999</b></li> <li>• Displays negative number, not responding to RTD.</li> </ul>	Check: <ol style="list-style-type: none"> <li>1. Input selected in <i>Setup</i> menu</li> <li>2. TC/RTD Switch position</li> <li>3. Corresponding signal at Signal connector</li> </ol>
Display alternates between <ol style="list-style-type: none"> <li>1. <b>H i</b> and a number</li> <li>2. <b>Lo</b> and a number</li> </ol>	Press <b>Menu</b> to exit Max/Min display readings.
Display response is too slow	Check filter and bypass values

Symptom	Check/Action
Inaccurate temperature reading	Check: 1. Temperature units (°F or °C) 2. TC type or RTD curve selected 3. Offset adjustment 4. TC wire used 5. Calibration
If the display locks up or the meter does not respond at all	Cycle the power to restart the microprocessor.
Relay operation is reversed	Check: 1. Fail-safe in <i>Setup</i> menu 2. Wiring of relay contacts
Relay and status LED do not respond to signal	Check: 1. Relay action in <i>Setup</i> menu 2. Set and reset points
Meter not communicating with MeterView® or other programs	Check: 1. Serial adapter and cable 2. Serial protocol selected 3. Meter address and baud rate 4. MeterView address and baud rate
Other symptoms not described above	Call Technical Support for assistance.

## Quick Interface Reference Guide

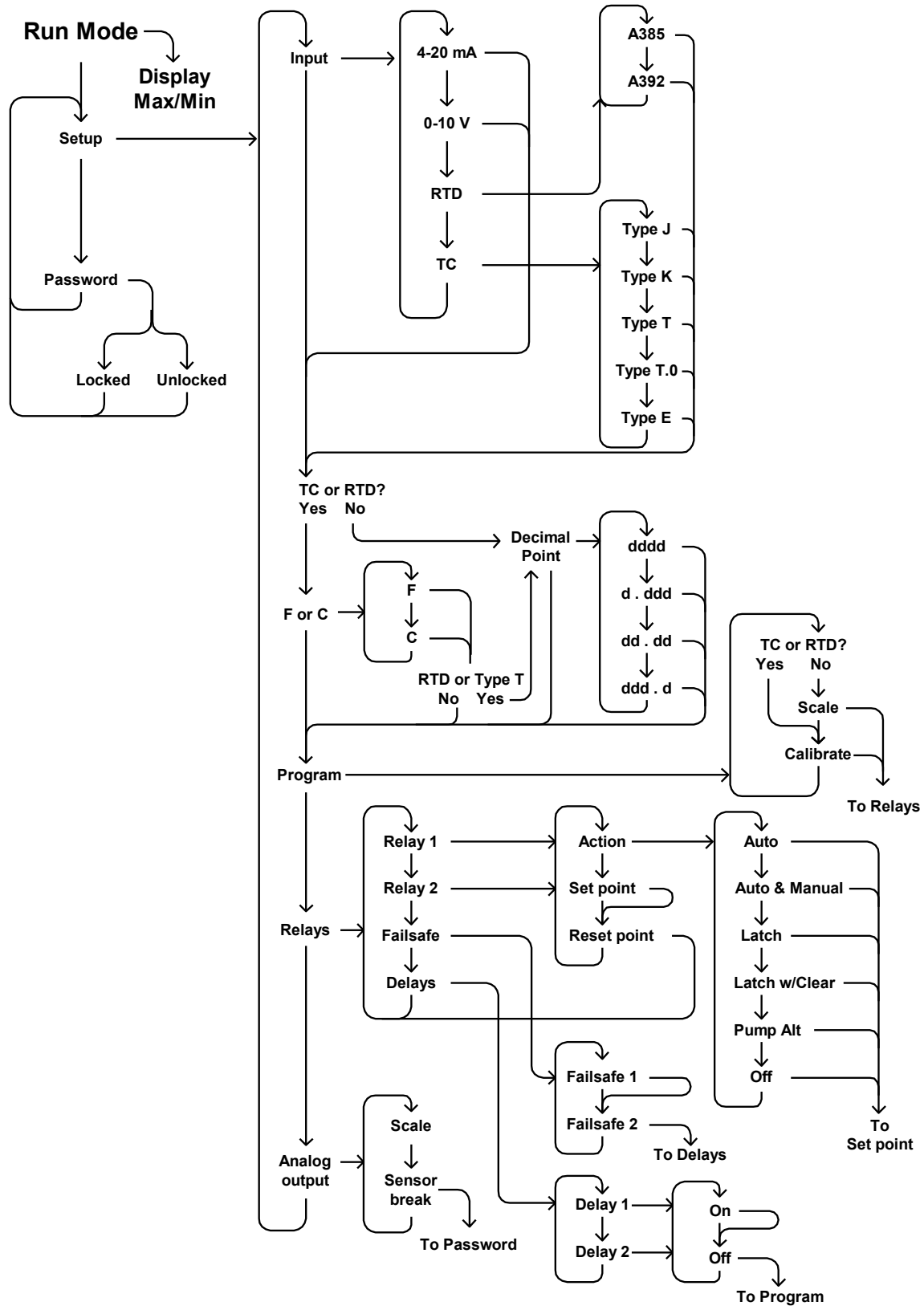

<u>Pushbutton</u>	<u>Function</u>
<b>Menu</b>	Go to Programming Mode or leave Programming, Advanced Features, and Max/Min Modes.
<b>Right Arrow</b>	Move to next digit.
<b>Up Arrow</b>	Move to next selection or increment digit.
<b>Enter/Ack</b>	Accept selection/value and move to next selection.

Press and hold **Menu** button for 3 seconds to enter Advanced Features

**Max/Min Mode**  
 While in Run Mode, pressing **Up Arrow** will initiate Max/Min Mode. **Up Arrow** toggles between Max & Min displays, and **Right Arrow** resets the Max/Min to the current value. Press **Menu** or wait 10 seconds to return to Run Mode. Pressing **Enter/Ack** will disable the 10 second timeout and continuously display Max or Min.

Press and hold **Menu** button to access Advanced Features Menu

When the meter is locked, Adjust, Filter and Bypass can only display their settings, and the Copy and ICAL functions are not available.

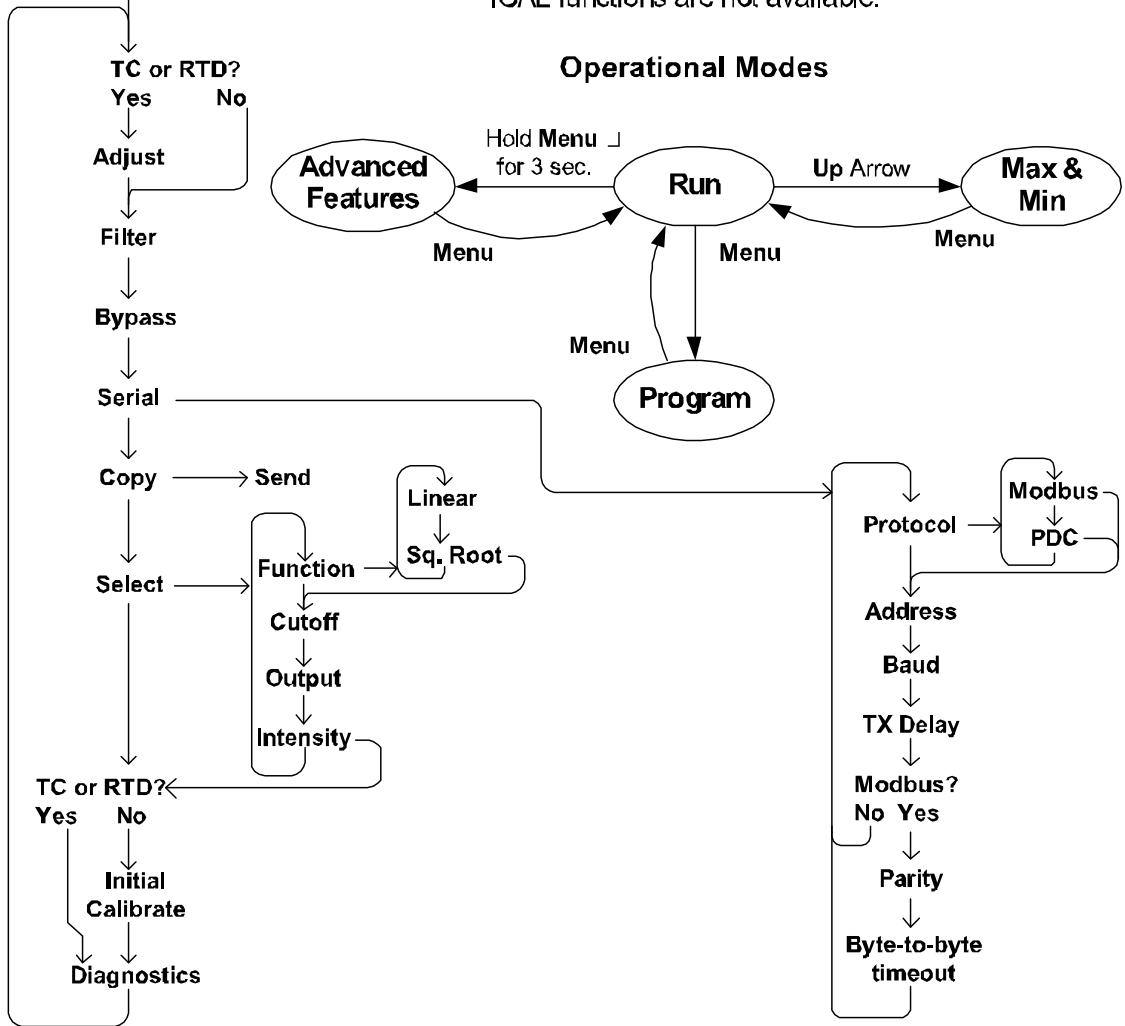



# EU Declaration of Conformity

Issued in accordance with ISO/IEC 17050-1:2004 and ATEX Directive 2014/34/EU.

We,

**Precision Digital Corporation**  
**233 South Street**  
**Hopkinton, MA 01748 USA**

as the manufacturer, declare under our sole responsibility that the product(s),

**Model PD8 ProtEX-MAX Series**

to which this declaration relates, is in conformity with the European Union Directives shown below:

<b>2014/35/EU</b>	<b>Low Voltage Directive</b>
<b>2014/34/EU</b>	<b>ATEX Directive</b>
<b>2014/30/EU</b>	<b>EMC Directive</b>
<b>2011/65/EU</b>	<b>RoHS Directive</b>

This conformity is based on compliance with the application of harmonized or applicable technical standards and, when applicable or required, a European Union notified body certification.

## Standards:

EN 55022:2007	EN 61000-6-2:2005	EN 60079-0:2009	EN 61000-6-4:2007
EN 60079-1:2007	EN 61010-1:2001	EN 60079-31:2008	EN 61326:2006

The standards EN 55022:2007, EN 60079-0:2009, EN 60079-1:2007, EN 60079-31:2008, EN 61000-6-4:2007, EN 61010-1:2001, and EN 61326:2006 are no longer harmonized. The requirements of these standards have been checked against the harmonized standard EN 55022:2010, EN 60079-0:2012+A11:2013, EN 60079-1:2014, EN 60079-31:2014, EN 61000-6-4:2007+A1:2011, EN 61010-1:2010, and EN 61326:2013 and there were no major technical changes affecting the latest technical knowledge for the products listed above.

**EC Type Examination Certificate:** Sira 12ATEX1182

## Product Markings:

 II 2 G D  
Ex d IIC T\* Gb  
Ex tb IIIC T90°C Db IP68  
Tamb = -40°C to +\*°C (\*T5 = 65°C, \*T6 = 60°C)

**ATEX Notified Body for EC Type Examination Certificate:** Sira Certification Service, NB 0518  
Unit 6, Hawarden Industrial Park  
Hawarden, Deeside, CH5 3US, UK

**ATEX Quality Assurance Notification No.:** SIRA 10 ATEX M462

**ATEX Notified Body for Quality Assurance:** Sira Certification Service, NB 0518  
Unit 6, Hawarden Industrial Park  
Hawarden, Deeside, CH5 3US, UK

Signed for and on behalf of Precision Digital Corporation:



Name: Jeffrey Peters  
Company: Precision Digital Corporation  
Title: President  
Date: 02/12/2018



Document No: DoC PD8 {021218}

## How to Contact Precision Digital

- For Technical Support please  
Call: (800) 610-5239 or (508) 655-7300  
Fax: (508) 655-8990  
Email: [support@predig.com](mailto:support@predig.com)
- For Sales Support or to place an order please  
Call: (800) 343-1001 or (508) 655-7300  
Fax: (508) 655-8990  
Email: [sales@predig.com](mailto:sales@predig.com)
- For the latest version of this manual please visit  
[www.predig.com](http://www.predig.com)
- For an *Interactive Virtual Meter Demo* please visit  
[tvm.predig.com](http://tvm.predig.com)

### PRECISION DIGITAL CORPORATION

233 South Street • Hopkinton MA 01748 USA  
Tel (800) 343-1001 • Fax (508) 655-8990



[www.predig.com](http://www.predig.com)