

# PROVU PD6310 Pulse Input Batch Controller

## Instruction Manual



**PROVU**<sup>®</sup>  
SERIES



**Batch Controller**

- Pulse, Open Collector, NPN, PNP, TTL, Switch Contact, Sine Wave (Coil), Square Wave Inputs
- 5, 10, or 24 V Flowmeter Power Supply
- K-Factor, Internal Scaling, or External Calibration
- Start, Batch, Pause, & Stop with Front Panel Buttons
- Display Batch Total + Rate, Grand Total, Batch Count or Preset
- Single or Multi-Stage Batching with up to 8 Relays
- Automatic Overflow Protection
- Manual Control or Automatic Batching
- Dual-Line Display
- NEMA 4X and IP65 Rated Front Panel
- UL Listed & CE Marked
- Display Features 0.6" & 0.46" Digits
- Six Full Digits on Each Line
- Optional Superluminous Sunlight Readable Display
- Free USB Programming Software & Cable
- 2 or 4 Relays + Isolated 4-20 mA Output Options
- Input Power Options Include 85-265 VAC or 12-24 VDC
- Isolated 24 VDC @ 200 mA Transmitter Power Supply
- Modbus<sup>®</sup> RTU Communication Protocol Standard

### PRECISION DIGITAL CORPORATION

233 South Street • Hopkinton MA 01748 USA  
Tel (800) 343-1001 • Fax (508) 655-8990

**PRECISION  
DIGITAL** ÷

[www.predig.com](http://www.predig.com)

## Disclaimer

The information contained in this document is subject to change without notice. Precision Digital makes no representations or warranties with respect to the contents hereof; and specifically disclaims any implied warranties of merchantability or fitness for a particular purpose.



**CAUTION:** *Read complete instructions prior to installation and operation of the controller.*



**WARNING:** *Risk of electric shock or personal injury.*



### Warning

***This product is not recommended for life support applications or applications where malfunctioning could result in personal injury or property loss. Anyone using this product for such applications does so at his/her own risk. Precision Digital Corporation shall not be held liable for damages resulting from such improper use.***

## Limited Warranty

Precision Digital Corporation warrants this product against defects in material or workmanship for the specified period under “Specifications” from the date of shipment from the factory. Precision Digital’s liability under this limited warranty shall not exceed the purchase value, repair, or replacement of the defective unit.

## Registered Trademarks

PROVU® and MeterView® Pro are registered trademarks of Precision Digital Corporation. Modbus® is a Registered Trademark of Schneider Automation Inc. All other trademarks mentioned in this document are the property of their respective owners.

© 2017 Precision Digital Corporation. All rights reserved.

**[www.predig.com](http://www.predig.com)**

# Table of Contents

<b>Table of Contents</b> .....	<b>3</b>	Reset .....	29
<b>Table of Figures</b> .....	<b>4</b>	Batch Start Mode ( <i>nr adE</i> ) .....	30
<b>Introduction</b> .....	<b>4</b>	Calibrating the Controller with External Source	
<b>Ordering Information</b> .....	<b>5</b>	( <i>IRL</i> ) .....	30
<b>Specifications</b> .....	<b>6</b>	Setting the Display Parameter & Intensity ( <i>dSPLY</i> )	
<b>General</b> .....	<b>6</b>	.....	31
<b>Pulse Input</b> .....	<b>6</b>	<b>Setting the Relay Operation (<i>rELAY</i>)</b> .....	<b>32</b>
<b>Batch Controller Rate/Totalizer Display</b> .....	<b>7</b>	Relay Assignment ( <i>R55 iLn</i> ) .....	33
<b>Relays</b> .....	<b>7</b>	Setting the Relay Action .....	33
<b>Isolated 4-20 mA Transmitter Output</b> .....	<b>8</b>	Setting Batch Control Relays .....	33
<b>Modbus® RTU Serial Communications</b> .....	<b>8</b>	Programming Alarm Set and Reset Points .....	34
<b>PDA1044 Digital Input &amp; Output Expansion Module</b>		Setting Fail-Safe Operation .....	34
.....	<b>8</b>	Programming Time Delay .....	34
<b>MeterView Pro</b> .....	<b>8</b>	<b>Relay Operation Details</b> .....	<b>35</b>
<b>Compliance Information</b> .....	<b>9</b>	Overview .....	35
<b>Safety</b> .....	<b>9</b>	Relays Initialization .....	35
<b>Electromagnetic Compatibility</b> .....	<b>9</b>	Fail-Safe Operation .....	35
<b>Safety Information</b> .....	<b>10</b>	Front Panel LEDs .....	35
<b>Installation</b> .....	<b>10</b>	Automatic Reset ( <i>RuLo</i> ) .....	36
<b>Unpacking</b> .....	<b>10</b>	Pump Alternation Control .....	36
<b>Panel Mounting Instructions</b> .....	<b>10</b>	Setting Up the Interlock Relay (Force On) Feature	36
Mounting Dimensions .....	11	Sample Relay Operation .....	37
<b>Transmitter Supply Voltage Selection (P+, P-)</b> .....	<b>11</b>	<b>Relay and Alarm Operation Diagrams</b> .....	<b>37</b>
<b>Connections</b> .....	<b>12</b>	High Alarm Operation (Set > Reset) .....	37
Connectors Labeling .....	12	Low Alarm Operation (Set < Reset) .....	37
Power Connections .....	12	High Alarm with Fail-Safe Operation (Set > Reset)	
Pulse Signal Connections .....	13	.....	37
Modbus RTU Serial Communications .....	13	Low Alarm with Fail-Safe Operation (Set < Reset)	37
Relay Connections .....	13	Rate Relay Sampling Operation .....	38
Switching Inductive Loads .....	14	Total Relay Sampling Operation .....	38
F4 Digital Input Connections .....	14	Time Delay Operation .....	39
4-20 mA Output Connections .....	15	<b>Scaling the 4-20 mA Analog Output (<i>Rout</i>)</b> .....	<b>39</b>
Analog Output Transmitter Power Supply .....	15	<b>Reset Menu (<i>rESEt</i>)</b> .....	<b>40</b>
External Relay & Digital I/O Connections .....	15	<b>Control Menu (<i>ContrL</i>)</b> .....	<b>40</b>
Interlock Relay Feature .....	16	<b>Setting Up the Password (<i>PR55</i>)</b> .....	<b>40</b>
<b>Basic Operation and Programming</b> .....	<b>17</b>	Protecting or Locking the Controller .....	40
<b>Front Panel Buttons and Status LED Indicators</b> .....	<b>17</b>	Grand Total Reset Password & Non-Resettable	
<b>Controller Operation</b> .....	<b>18</b>	Total .....	41
Batch Control Operation Example .....	19	Making Changes to a Password Protected	
<b>MeterView® Pro Software</b> .....	<b>20</b>	Controller .....	41
MeterView Pro Installation .....	21	Disabling Password Protection .....	41
<b>Display Functions and Messages</b> .....	<b>22</b>	<b>Advanced Operation and Programming</b> .....	<b>42</b>
<b>Setting Numeric Values</b> .....	<b>24</b>	Advanced Features Menu & Display Messages .....	42
<b>Setting Up the Batch Controller (<i>SEtUP</i>)</b> .....	<b>25</b>	Function Keys Operation .....	44
Scaling and Calibration .....	26	F4 Operation .....	44
Setting the Input Signal ( <i>inPUt</i> ) .....	26	Multi-Point Calibration & Scaling .....	44
Setting the Totalizer and Batching Features ( <i>totRL</i> )		Maximum/Minimum Readings .....	44
.....	26	Noise Filter ( <i>F iLTER</i> ) .....	45
Setting the Input Units or Custom Tags ( <i>un itS</i> ) .....	26	Noise Filter Bypass ( <i>bYPASS</i> ) .....	45
Setting the Decimal Point ( <i>dEc Pt</i> ) .....	27	Rounding Feature ( <i>rounD</i> ) .....	45
Programming the Batch Controller ( <i>PRaU</i> ) .....	27	Modbus RTU Serial Communications ( <i>SEr iRL</i> ) .....	45
Input Calibration Method ( <i>inIRL</i> ) .....	28	Select Menu ( <i>SELEct</i> ) .....	46
K-Factor Calibration ( <i>FRcTOR</i> ) .....	28	Signal Conditioning Selection ( <i>FuncTn</i> ) .....	46
Scaling the Controller ( <i>ScALe</i> ) .....	29	Low-Flow Cutoff ( <i>LUtOFF</i> ) .....	46
Time Base, Total Conversion Factor & Total		Total and Grand Total Count Direction ( <i>COunT</i> )	46
		Analog Output Programming ( <i>ROuTPr</i> ) .....	47
		Programmable Function Keys User Menu ( <i>u5Er</i> ) .....	47

<b>Troubleshooting</b> .....	<b>49</b>	Factory Defaults & User Settings.....	50
Diagnostics Menu ( <i>d</i> <i>RL</i> ).....	49	<b>Troubleshooting Tips</b> .....	<b>52</b>
Determining Software Version .....	49	<b>EU Declaration of Conformity</b> .....	<b>53</b>
Reset Controller to Factory Defaults.....	49		

## Table of Figures

Figure 1: 1/8 DIN Panel Mounting .....	10	Figure 11: PNP Sensor Powered by Internal Supply	13
Figure 2: Controller Dimensions - Side View.....	11	Figure 12: Switch Input Connections.....	13
Figure 3: Controller Dimensions - Top View.....	11	Figure 13: Relay Connections .....	13
Figure 4: Transmitter Supply Voltage Selection.....	11	Figure 14: AC and DC Loads Protection.....	14
Figure 5: Connector Labeling for Fully Loaded PD6310 .....	12	Figure 15: Low Voltage DC Loads Protection .....	14
Figure 6: Power Connections.....	12	Figure 16: F4 Digital Input Connections .....	14
Figure 7: Flowmeter Powered by Internal Power Supply .....	13	Figure 17: 4-20 mA Output Connections .....	15
Figure 8: Flowmeter Powered by External Supply ...	13	Figure 18: Expansion Modules & DIN Rail Mounting Kit .....	15
Figure 9: Self-Powered Magnetic Pickup Coil Flowmeter .....	13	Figure 19: External Relays Module Connections.....	15
Figure 10: NPN open Collector Input.....	13	Figure 20: Digital I/O Module Connections .....	15
		Figure 21: Interlock Connection .....	16

## Introduction

The PROVU® PD6310 is an easy-to-use batch controller ideal for simplifying independent batch control operations where local control is preferred to expensive and expansive plant operation systems. Its superluminous LED digits make it easily readable in smoke, dust, fog, and, with the optional SunBright® display, even direct sunlight.

The controller comes programmed for easy front panel start, pause, stop, and batch size (preset) changes. The bottom display can be programmed to display rate, grand total, batch count, or preset by cycling the Stop (F3) button. A digital input is standard.

Single and multi-stage batching is possible with up to four (4) on-board relays and four (4) external relays with the external relay module. Each batch control relay may have a unique preclose amount when used for multi-stage batching.

Manual start batching is default, but automatic batching with a restart after a programmed time delay from the completion of the last batch, is also possible.

Overrun correction adjusts the closing of the batch control relays to adjust for inaccuracies from batch to batch. This increases accuracy over time as systems wear out. The overrun correction feature is capable of compensating for inaccuracies of up to 10% of the programmed preset value.

At least two SPDT relays are included for use in batch control or rate alarms.

The batch controllers also share all common PROVU Series features, including an isolated 24 VDC transmitter power supply and Modbus RTU Serial communications.

## Ordering Information

### Standard Models

85-265 VAC Model	12-24 VDC Model	Options Installed
PD6310-6R2	PD6310-7R2	2 relays (PD1102*)
PD6310-6R4	PD6310-7R4	4 relays (PD1104*)
PD6310-6R5	PD6310-7R5	2 relays & 4-20 mA output (PD1105*)
PD6310-6R7	PD6310-7R7	4 relays & 4-20 mA output (PD1107*)
*Model number for replacement option card.		

### SunBright Display Models

85-265 VAC Model	12-24 VDC Model	Options Installed
PD6310-6H2	PD6310-7H2	2 relays (PD1102*)
PD6310-6H4	PD6310-7H4	4 relays (PD1104*)
PD6310-6H5	PD6310-7H5	2 relays & 4-20 mA output (PD1105*)
PD6310-6H7	PD6310-7H7	4 relays & 4-20 mA output (PD1107*)
*Model number for replacement option card.		

### Accessories

Model	Description
PDA1002	DIN rail mounting kit for two expansion modules
PDA1004	4 SPST (Form A) relays
PDA1044	4 digital inputs & 4 digital outputs (2 may be connected)
PDA1232	RS-232 serial adapter
PDA1485	RS-485 serial adapter
PDA7485-I	RS-232 to RS-422/485 isolated converter
PDA8232-N	USB to RS-232 non-isolated converter
PDA8485-I	USB to RS-422/485 isolated converter
PDA2811	1 Meter Plastic NEMA 4X Enclosure
PDA2812	2 Meter Plastic NEMA 4X Enclosure
PDX6901	Suppressor (snubber): 0.01 $\mu$ F/470 $\Omega$ , 250 VAC

## Specifications

Except where noted all specifications apply to operation at +25°C.

### General

<b>Display</b>	Line 1: 0.6" (15 mm) high, red LEDs Line 2: 0.46" (12 mm) high, red LEDs 6 digits: each (-99999 to 999999), with lead zero blanking.
<b>Default Display Assignment</b>	The Upper display shows batch total. The Lower display shows rate with alternating units, and can be switched to show grand total, batch count, or preset with the STOP key.
<b>Custom Display Assignment</b>	The Upper and Lower displays may be assigned to rate, total, grand total, batch count, preset, set points, units (lower display only), alternating R & T, R & GT, preset & rate, max & min, or a Modbus display register. Any rate/total/grand total display may be programmed to alternate with a custom unit or tag.
<b>Alternating Display</b>	Displays alternate every 10 seconds when display is selected or the batch is paused.
<b>Display Intensity</b>	Eight user selectable intensity levels
<b>Display Update Rate</b>	5/second (200 ms)
<b>Overrange</b>	Display flashes <b>999999</b>
<b>Underrange</b>	Display flashes <b>-99999</b>
<b>Front Panel</b>	NEMA 4X, IP65
<b>Programming Methods</b>	Four front panel buttons, digital inputs, or PC and MeterView Pro software.
<b>Recalibration</b>	All ranges are calibrated at the factory. Recalibration is recommended at least every 12 months.
<b>Max/Min Display</b>	Max/min readings reached by the process are stored until reset by the user or until power to the controller is cycled.
<b>Password</b>	Three programmable passwords restrict modification of programmed settings and two prevent resetting the totals. Pass 1: Allows use of function keys and digital inputs Pass 2: Allows use of function keys, digital inputs and editing set/reset points Pass 3: Restricts all programming, function keys, and digital inputs. Total Password: Prevents resetting the total manually Gtotal Password: Prevents resetting the grand total manually
<b>Non-Volatile Memory</b>	All programmed settings are stored in non-volatile memory for a minimum of ten years if power is lost.
<b>Power Options</b>	85-265 VAC 50/60 Hz, 90-265 VDC, 20 W max or 12-24 VDC ± 10%, 15 W max Powered over USB for configuration only
<b>Fuse</b>	Required external fuse: UL Recognized, 5 A max, slow blow; up to 6 controllers may share one 5 A fuse

<b>Isolated Transmitter Power Supply</b>	Terminals P+ & P-: 24 VDC ± 10%. 12-24 VDC powered models selectable for 24, 10, or 5VDC supply (internal jumper J4). 85-265 VAC models rated @ 200 mA max, 12-24 VDC powered models rated @ 100 mA max, @ 50 mA max for 5 or 10 VDC supply.
<b>Normal Mode Rejection</b>	Greater than 60 dB at 50/60 Hz
<b>Isolation</b>	4 kV input/output-to-power line 500 V input-to-output or output-to-P+ supply
<b>Overvoltage Category</b>	Installation Overvoltage Category II: Local level with smaller transient overvoltages than Installation Overvoltage Category III.
<b>Environmental</b>	Operating temperature range: -40 to 65°C Storage temperature range: -40 to 85°C Relative humidity: 0 to 90% non-condensing
<b>Connections</b>	Removable screw terminal blocks accept 12 to 22 AWG wire, RJ45 for external relays, digital I/O, and serial communication adapters.
<b>Enclosure</b>	1/8 DIN, high impact plastic, UL 94V-0, color: black
<b>Mounting</b>	1/8 DIN panel cutout required: 3.622" x 1.772" (92 mm x 45 mm) Two panel mounting bracket assemblies are provided.
<b>Tightening Torque</b>	Screw terminal connectors: 5 lb-in (0.56 Nm)
<b>Overall Dimensions</b>	4.68" x 2.45" x 5.64" (119 mm x 62 mm x 143 mm) (W x H x D)
<b>Weight</b>	9.5 oz (269 g)
<b>Warranty</b>	3 years parts & labor

### Pulse Input

<b>Inputs</b>	Field selectable: Pulse or square wave 0-5 V, 0-12 V, or 0-24 V @ 30 kHz; TTL; open collector 4.7 kΩ pull-up to 5 V @ 30 kHz; NPN or PNP transistor, switch contact 4.7 kΩ pull-up to 5 V @ 40 Hz; Modbus PV (Slave)
<b>Low Voltage Mag Pickup (Isolated)</b>	Sensitivity: 40 mVp-p to 8Vp-p
<b>Minimum Input Frequency</b>	0.001 Hz Minimum frequency is dependent on high gate setting.
<b>Maximum Input Frequency</b>	30,000 Hz (10,000 for low voltage mag pickup)
<b>Input Impedance</b>	Pulse input: Greater than 300 kΩ @ 1 kHz. Open collector/switch input: 4.7 kΩ pull-up to 5 V.
<b>Accuracy</b>	±0.03% of calibrated span ±1 count
<b>Temperature Drift</b>	Rate display is not affected by changes in temperature.

<b>Multi-Point Linearization</b>	2 to 32 points
<b>Low-Flow Cutoff</b>	0-999999 (0 disables cutoff function)
<b>Decimal Point</b>	Up to five decimal places or none: <i>dddddd, d.ddddd, d.dddd, d.ddd, d.dd, d.d, or ddddd</i>
<b>Calibration</b>	May be calibrated using K-factor, internal calibration, or by applying an external calibration signal.
<b>K-Factor</b>	Field programmable K-factor converts input pulses to rate in engineering units. May be programmed from 0.00001 to 999,999 pulses/unit.
<b>Calibration Range</b>	Input 1 signal may be set anywhere in the range of the controller; input 2 signal may be set anywhere above or below input 1 setting. Minimum input span between any two inputs is 10 Hz. An error message will appear if the input 1 and input 2 signals are too close together.
<b>Filter</b>	Programmable contact de-bounce filter: 40 to 999 Hz maximum input frequency allowed with low speed filter.
<b>Time Base</b>	Second, minute, hour, or day
<b>Gate</b>	Low gate: 0.1-99.9 seconds High gate: 2.0-999.9 seconds
<b>F4 Digital Input Contacts</b>	3.3 VDC on contact. Connect normally open contacts across F4 to COM.
<b>F4 Digital Input Logic Levels</b>	Logic High: 3 to 5 VDC Logic Low: 0 to 1.25 VDC
<b>Batch Controller Rate/Totalizer Display</b>	
<b>Rate Display Indication</b>	-99999 to 999999, lead zero blanking. "R" LED illuminates while displaying rate.
<b>Batch Total &amp; Grand Total Display</b>	0 to 999,999; automatic lead zero blanking. "T" LED is illuminated while displaying batch total. "GT" LEDs are illuminated while displaying grand total. Up to 999,999 for batch total/preset. Up to 999,999,999 with grand total-overflow feature. "OF" is displayed to the left of grand total overflow and ▲ LED is illuminated.
<b>Batch Total Decimal Point</b>	Up to five decimal places or none: <i>d.ddddd, d.ddddd, d.dddd, d.ddd, d.dd, d.d, or ddddd</i> Total decimal point is independent of rate decimal point.
<b>Totalizer</b>	Calculates total based on rate and field programmable multiplier to display total in engineering units. Time base must be selected according to the time units in which the rate is displayed.
<b>Grand Totalizer Rollover</b>	Grand totalizer rolls over when display exceeds 999,999,999. Relay status reflects display.

<b>Grand Total Alarms</b>	Up to seven, user selectable under setup menu. Any set point can be assigned to grand total and may be programmed anywhere in the range of the controller for grand total alarm indication. Relay 1 should always be assigned to batch.
<b>Programmable Delay on Release</b>	0.1 and 999.9 seconds; applied to the first relay assigned to total or grand total. If the controller is programmed to reset total to zero automatically when the preset is reached, then a delay will occur before the total is reset.
<b>Grand Total Reset</b>	Via front panel button, external contact closure on digital inputs, automatically via user selectable preset value and time delay, or through serial communications.
<b>Grand Total Reset Password</b>	Grand total passwords may be entered to prevent resetting the grand total from the front panel.
<b>Non-Resetable Grand Total</b>	The grand total can be programmed as a non-resetable total by entering the password "050873".  <b>Caution!</b> <i>Once the Grand Total has been programmed as "non-resetable" the feature <u>cannot</u> be disabled.</i>

**Relays**

<b>Rating</b>	2 or 4 SPDT (Form C) internal and/or 4 SPST (Form A) external; rated 3 A @ 30 VDC and 125/250 VAC resistive load; 1/14 HP (≈ 50 W) @ 125/250 VAC for inductive loads
<b>Noise Suppression</b>	Noise suppression is recommended for each relay contact switching inductive loads; see page 14 for details.
<b>Relay Assignment</b>	Relays may be assigned to batch control total, sampling, rate, or grand total alarms.
<b>Preclose</b>	0-100% of batch size, individually user programmable for each additional batch control relay beyond the first.
<b>Alarm Deadband</b>	0-100% of span, user programmable
<b>High or Low Alarm</b>	User may program any alarm for high or low trip point. Unused alarm LEDs and relays may be disabled (turn off).
<b>Relay Operation</b>	Batch control Automatic (non-latching) <sup>1</sup> Sampling Off (disable unused relays and enable Interlock feature) Manual on/off control mode Secondary Functions <sup>2</sup> Pump alternation control (2 to 8 relays) Latching (requires manual acknowledge)

<b>Relay Reset</b>	User selectable via front panel buttons, digital inputs, or PC <ol style="list-style-type: none"> <li>Automatic reset only (non-latching), when the input passes the reset point or total is reset to zero.</li> <li>Automatic + manual reset at any time (non-latching)</li> <li>Manual reset only, at any time (latching)</li> <li>Manual reset only after alarm condition has cleared (L)</li> </ol> <p><i>Note: Digital inputs may be assigned to acknowledge relays programmed for manual reset. It is not recommended to change the functions of front panel buttons to manual reset.</i></p>
<b>Alarm Time Delay</b>	0 to 999.9 seconds, on & off relay time delays Programmable and independent for each relay.
<b>Fail-Safe Operation</b>	Programmable and independent for each relay. <i>Note: Relay coil is energized in non-alarm condition. In case of power failure, relay will go to alarm state.</i>
<b>Alarm Auto Initialization</b>	When power is applied to the controller, relays will reflect the state of the input to the controller. <sup>1</sup>

- Alarms are active only when the batch is running.
- These functions are not functional when the unit is being used as a batch controller with total set to yes.

### Isolated 4-20 mA Transmitter Output

<b>Output Source</b>	Rate/process, total, grand total, max, min, set points 1-8, Modbus register, or manual control mode
<b>Scaling Range</b>	1.000 to 23.000 mA for any display range.
<b>Calibration</b>	Factory calibrated: 4.000 to 20.000 = 4-20 mA output
<b>Analog Out Programming</b>	23.000 mA maximum for all parameters: Overrange, underrange, max, min, and break
<b>Accuracy</b>	± 0.1% FS ± 0.004 mA
<b>Temperature Drift</b>	0.4 µA/°C max from 0 to 65°C ambient, 0.8 µA/°C max from -40 to 0°C ambient <i>Note: Analog output drift is separate from input drift.</i>
<b>Isolated Transmitter Power Supply</b>	Terminals I+ & R: 24 VDC ± 10%. May be used to power the 4-20 mA output or other devices. Refer to Figure 6 on page 12 and Figure 17 on page 15. All models rated @ 40 mA max.

<b>External Loop Power Supply</b>	35 VDC maximum		
<b>Output Loop Resistance</b>	Power supply	Minimum	Maximum
	24 VDC	10 Ω	700 Ω
	35 VDC (external)	100 Ω	1200 Ω

### Modbus® RTU Serial Communications

<b>Slave Id</b>	1 – 247 (Controller address)
<b>Baud Rate</b>	300 - 19,200 bps
<b>Transmit Time Delay</b>	Programmable between 0 and 199 ms
<b>Data</b>	8 bit (1 start bit, 1 or 2 stop bits)
<b>Parity</b>	Even, Odd, or None with 1 or 2 stop bits
<b>Byte-To-Byte Timeout</b>	0.01 – 2.54 second
<b>Turn Around Delay</b>	Less than 2 ms (fixed)

*Note: Refer to the PROVU® Modbus Register Tables located at [www.predig.com](http://www.predig.com) for details.*

### PDA1044 Digital Input & Output Expansion Module

<b>Channels</b>	4 digital inputs & 4 digital outputs per module
<b>System</b>	Up to 2 modules for a total of 8 inputs & 8 outputs
<b>Digital Input Logic High</b>	3 to 5 VDC
<b>Digital Input Logic Low</b>	0 to 1.25 VDC
<b>Digital Output Logic High</b>	3.1 to 3.3 VDC
<b>Digital Output Logic Low</b>	0 to 0.4 VDC
<b>Source Current</b>	10 mA maximum output current
<b>Sink Current</b>	1.5 mA minimum input current
<b>+5 V Terminal</b>	To be used as pull-up for digital inputs only Connect normally open pushbuttons across +5 V & DI 1-4.

### MeterView Pro

<b>System Requirements</b>	Microsoft® Windows® XP/Vista/7/8/10
<b>Communications</b>	USB 2.0 (Standard USB A to Micro USB B)
<b>Configuration</b>	Configure meters one at a time



## Compliance Information

### Safety

<b>UL &amp; c-UL Listed</b>	USA & Canada UL 508 Industrial Control Equipment
<b>UL File Number</b>	E160849
<b>Front Panel</b>	UL Type 4X, NEMA 4X, IP65; panel gasket provided
<b>Low Voltage Directive</b>	EN 61010-1:2010 Safety requirements for measurement, control, and laboratory use

### Electromagnetic Compatibility

<b>Emissions</b>	EN 55022:2010 Class A ITE emissions requirements
Radiated Emissions	Class A
AC Mains Conducted Emissions	Class A
<b>Immunity</b>	EN 61326-1:2013 Measurement, control, and laboratory equipment EN 61000-6-2:2005 EMC heavy industrial generic immunity standard
RFI - Amplitude Modulated	80 -1000 MHz 10 V/m 80% AM (1 kHz) 1.4 - 2.0 GHz 3 V/m 80% AM (1 kHz) 2.0 - 2.7 GHz 1 V/m 80% AM (1 kHz)
Electrical Fast Transients	±2kV AC mains, ±1kV other
Electrostatic Discharge	±4kV contact, ±8kV air
RFI - Conducted	10V, 0.15-80 MHz, 1kHz 80% AM
AC Surge	±2kV Common, ±1kV Differential
Surge	1KV (CM)
Power-Frequency Magnetic Field	30 A/m 70%V for 0.5 period
Voltage Dips	40%V for 5 & 50 periods 70%V for 25 periods
Voltage Interruptions	<5%V for 250 periods

**Note:**

Testing was conducted on PD6200 and PD6300 series meters installed through the covers of grounded metal enclosures with cable shields grounded at the point of entry representing installations designed to optimize EMC performance. All hardware is identical to the PD6310 controllers.

Declaration of Conformity available at [www.predig.com](http://www.predig.com)

## Safety Information

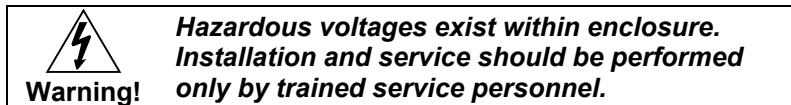
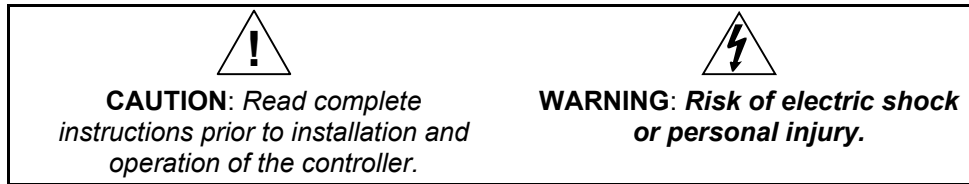

## Installation

There is no need to remove the controller from its case to complete the installation, wiring, and setup of the controller for most applications. Instructions are provided for changing the transmitter power supply to output 5 or 10 VDC instead of 24 VDC, see page 11.

## Unpacking

Remove the controller from box. Inspect the packaging and contents for damage. Report damages, if any, to the carrier.

If any part is missing or the controller malfunctions, please contact your supplier or the factory for assistance.

## Panel Mounting Instructions

- Prepare a standard 1/8 DIN panel cutout – 3.622" x 1.772" (92 mm x 45 mm). Refer to Figure 1 for more details.
- Clearance: allow at least 6.0" (152 mm) behind the panel for wiring.
- Panel thickness: 0.04" - 0.25" (1.0 mm - 6.4 mm).  
Recommended minimum panel thickness to maintain Type 4X rating: 0.06" (1.5 mm) steel panel, 0.16" (4.1 mm) plastic panel.
- Remove the two mounting brackets provided with the controller (back-off the two screws so that there is ¼" (6.4 mm) or less through the bracket. Slide the bracket toward the front of the case and remove).
- Insert controller into the panel cutout.
- Install mounting brackets and tighten the screws against the panel. To achieve a proper seal, tighten the mounting bracket screws evenly until controller is snug to the panel along its short side. **DO NOT OVER TIGHTEN**, as the rear of the panel may be damaged.

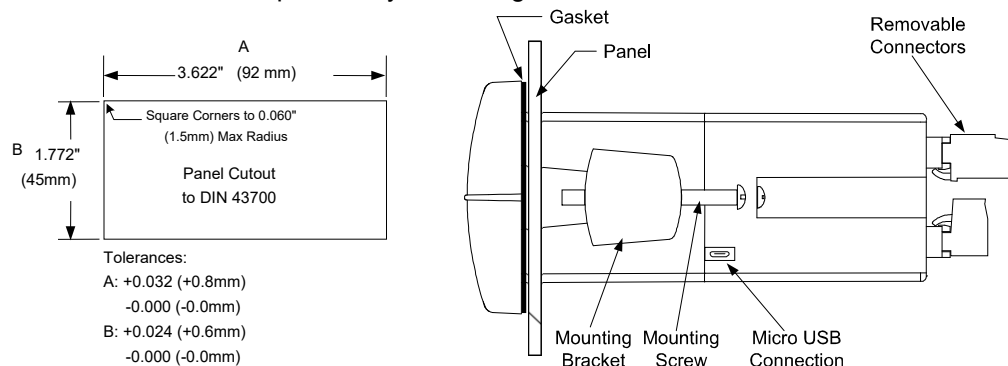
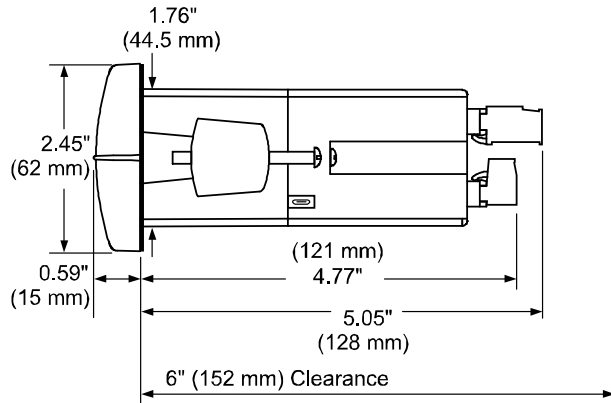
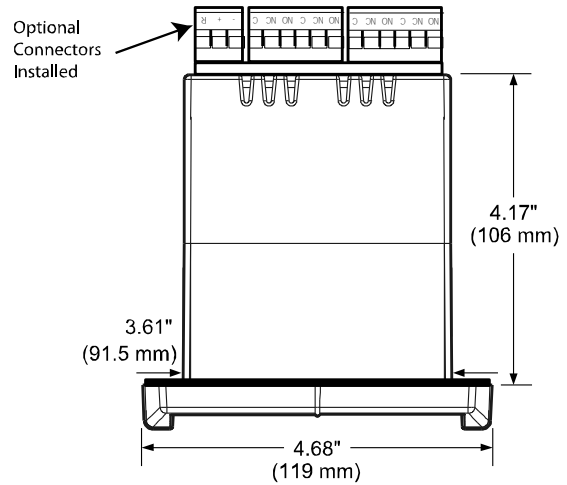

Figure 1: 1/8 DIN Panel Mounting

## Mounting Dimensions



**Figure 2: Controller Dimensions - Side View**



**Figure 3: Controller Dimensions - Top View**

## Transmitter Supply Voltage Selection (P+, P-)

All controllers, including models equipped with the 12-24 VDC power option, are shipped from the factory configured to provide 24 VDC power for the transmitter or sensor.

If the transmitter requires 5 or 10 VDC excitation, the internal jumper J4 must be configured accordingly.

To access the voltage selection jumper:

1. Remove all the connectors.
2. Unscrew the back cover.
3. Slide the back cover about 1 inch.
4. Configure the J4 jumper, located behind the input signal connector, for the desired excitation voltage as shown.

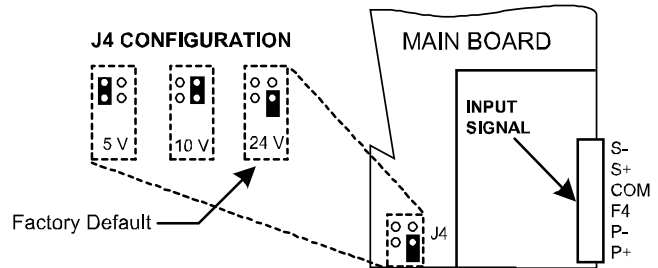

**Figure 4: Transmitter Supply Voltage Selection**

## Connections

All connections are made to removable screw terminal connectors located at the rear of the controller.



**Caution!** Use copper wire with 60°C or 60/75°C insulation for all line voltage connections. Observe all safety regulations. Electrical wiring should be performed in accordance with all applicable national, state, and local codes to prevent damage to the controller and ensure personnel safety.

### Connectors Labeling

The connectors' label, affixed to the controller, shows the location of all connectors available with requested configuration.



**Warning!** Do not connect any equipment other than Precision Digital's expansion modules, cables, or controllers to the RJ45 M-LINK connector. Otherwise damage will occur to the equipment and the controller.

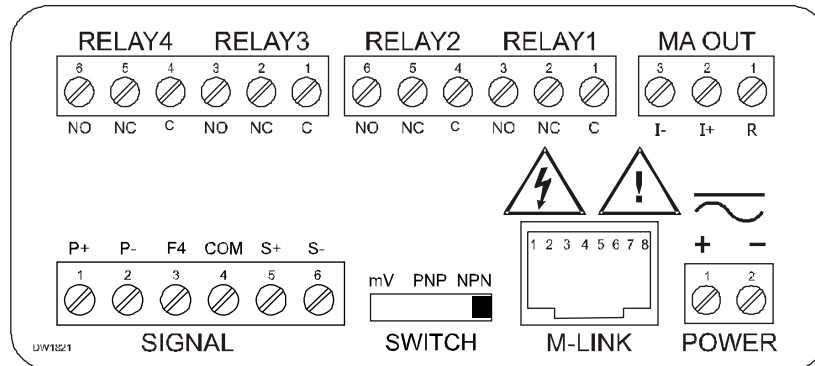

**Figure 5: Connector Labeling for Fully Loaded PD6310**

### Power Connections

Power connections are made to a two-terminal connector labeled POWER on Figure 6. The controller will operate regardless of DC polarity connection. The + and - symbols are only a suggested wiring convention.

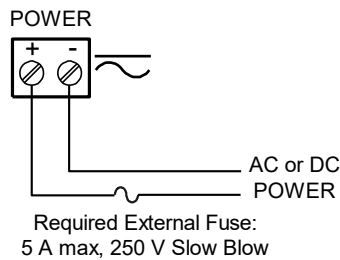

**Figure 6: Power Connections**

### Pulse Signal Connections

Signal connections are made to a six-terminal connector labeled SIGNAL on Figure 7. The COM (common) terminal is the return for the input signals.

The following figures show examples of signal connections.

Setup and programming is performed through the front panel buttons.

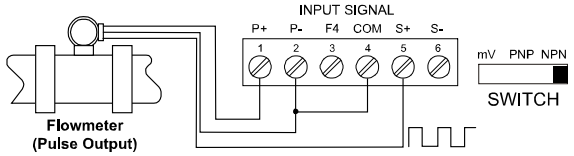

**Figure 7: Flowmeter Powered by Internal Power Supply**

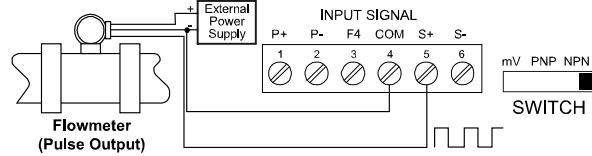

**Figure 8: Flowmeter Powered by External Supply**

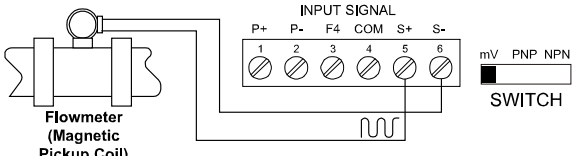

**Figure 9: Self-Powered Magnetic Pickup Coil Flowmeter**

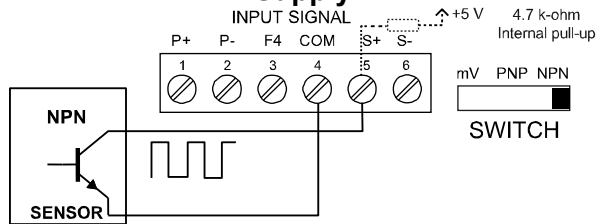

**Figure 10: NPN open Collector Input**

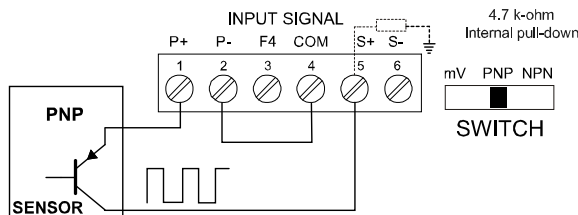

**Figure 11: PNP Sensor Powered by Internal Supply**

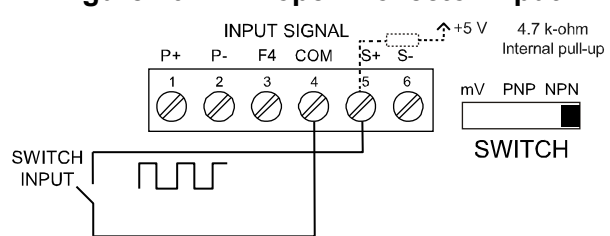

**Figure 12: Switch Input Connections**

### Modbus RTU Serial Communications

Serial communications connection is made to an RJ45 connector labeled M-LINK on Figure 7. Use the PDA1232 for RS-232 interfacing or the PDA1485 for RS-485 interfacing. The same port is used for interfacing with all expansion modules (e.g. external relays, digital I/O).

### Relay Connections

Relay connections are made to two six-terminal connectors labeled RELAY1 – RELAY4 on Figure 7. Each relay's C terminal is common only to the normally open (NO) and normally closed (NC) contacts of the corresponding relay. The relays' C terminals should not be confused with the COM (common) terminal of the INPUT SIGNAL connector.

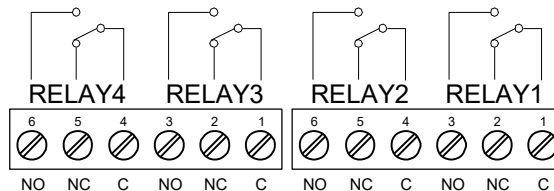

**Figure 13: Relay Connections**

### Switching Inductive Loads

The use of suppressors (snubbers) is strongly recommended when switching inductive loads to prevent disrupting the microprocessor's operation. The suppressors also prolong the life of the relay contacts. Suppression can be obtained with resistor-capacitor (RC) networks assembled by the user or purchased as complete assemblies. Refer to the following circuits for RC network assembly and installation:

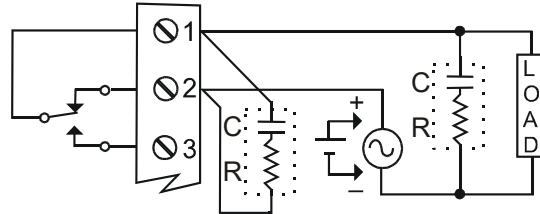

**Figure 14: AC and DC Loads Protection**

Choose R and C as follows:

- R: 0.5 to 1  $\Omega$  for each volt across the contacts
- C: 0.5 to 1  $\mu\text{F}$  for each amp through closed contacts

Notes:

1. Use capacitors rated for 250 VAC.
2. RC networks may affect load release time of solenoid loads. Check to confirm proper operation.
3. Install the RC network at the controller's relay screw terminals. An RC network may also be installed across the load. Experiment for best results.

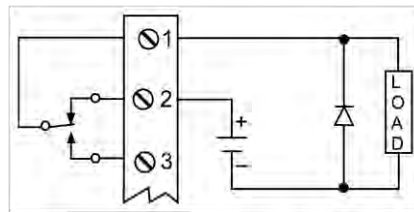

Use a diode with a reverse breakdown voltage two to three times the circuit voltage and forward current at least as large as the load current.

**Figure 15: Low Voltage DC Loads Protection**

### RC Networks Available from Precision Digital

RC networks are available from Precision Digital and should be applied to each relay contact switching an inductive load. Part number: PDX6901.

Note: Relays are de-rated to 1/14th HP (50 watts) with an inductive load.

### F4 Digital Input Connections

A digital input, F4, is standard on the meter. This digital input connected with a normally open closure across F4 and COM, or with an active low signal applied to F4.

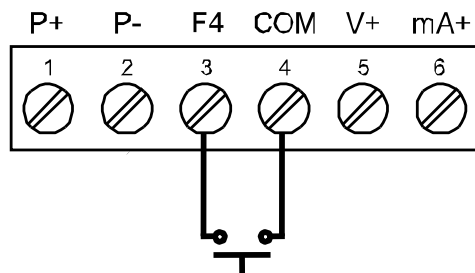

**Figure 16: F4 Digital Input Connections**

### 4-20 mA Output Connections

Connections for the 4-20 mA transmitter output are made to the connector terminals labeled MA OUT. The 4-20 mA output may be powered internally or from an external power supply.

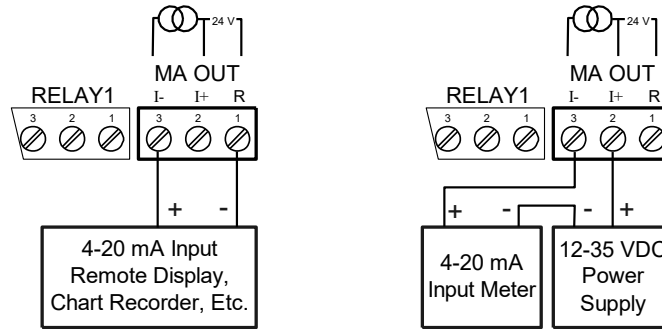

Figure 17: 4-20 mA Output Connections

### Analog Output Transmitter Power Supply

The internal 24 VDC power supply powering the analog output may be used to power other devices, if the analog output is not used. The I+ terminal is the +24 V and the R terminal is the return.

### External Relay & Digital I/O Connections

The relay and the digital I/O expansion modules PDA1004 & PDA1044 are connected to the controller using a CAT5 cable provided with each module. The two RJ45 connectors on the expansion modules are identical and interchangeable; they are used to connect additional modules to the system.

*Note: The jumper located between the RJ45 connectors of the PDA1044 must be removed on the second digital I/O module in order for the system to recognize it as module #2.*



**Warning!** Do not connect or disconnect the expansion modules with the power on! More detailed instructions are provided with each optional expansion module.

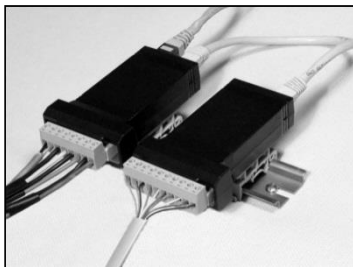

Figure 18: Expansion Modules & DIN Rail Mounting Kit

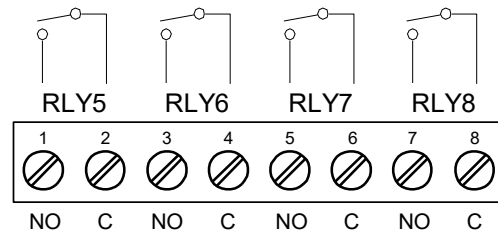

Figure 19: External Relays Module Connections

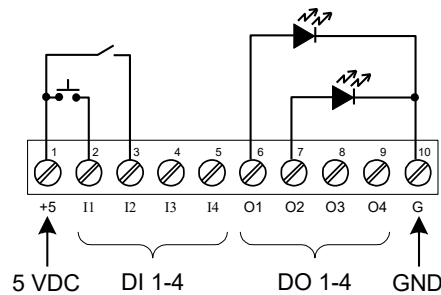
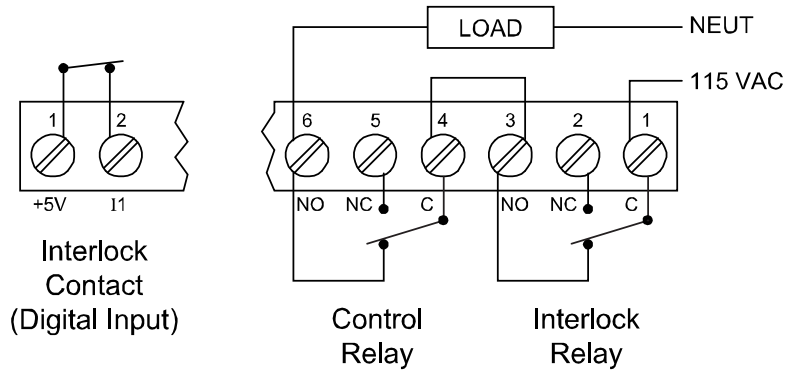

Figure 20: Digital I/O Module Connections

### Interlock Relay Feature

As the name implies, the interlock relay feature reassigns one, or more, alarm/control relays for use as interlock relay(s). Interlock contact(s) are wired to digital input(s) and trigger the interlock relay. This feature is enabled by configuring the relay, and relative digital input(s) (see page 36). In one example, dry interlock contacts are connected in series to one digital input which will be used to force on (energize) the assigned interlock power relay when all interlock contacts are closed (safe). The interlock relay front panel LED flashes when locked out. The interlock relay would be wired in-series with the load (N/O contact). See below.



**Figure 21: Interlock Connection**



## Basic Operation and Programming

The PD6310 has been factory calibrated to read input frequency in Hz (pulses/sec). The calibration equipment is certified to NIST standards.

### Overview

Most setup and programming is done through the front panel buttons.

There is one switch located to the right of the input connector, which must be configured according to the input level and type. Jumper J4 located inside the controller, behind the input signal connector, is used to select the excitation voltage (24 V (*Default Setting*), 10 V or 5 V) which is supplied to the P+ and P- wiring terminals.

After power and input signal connections have been completed and verified, apply power to the controller.

### Front Panel Buttons and Status LED Indicators



Button Symbol	Description
	<b>Menu</b>
	<b>START (Right arrow/F1)</b>
	<b>BATCH (Up arrow/F2)</b>
	<b>STOP (Enter/F3)</b>
<p><i>Note:</i> F4 is a digital input. Alarms 5-8 enabled when relay expansion module is installed.</p>	

LED	Status
1-8	Relay 1 – 8 indicators
R	Rate indicator
T	Batch Total indicator
G T	Grand Total indicator
▲	Total overflow indicator
M	Manual control relays &/or analog output

### Programming

- Press the Menu button to enter or exit the Programming Mode at any time.
- Press the Right arrow button to move to the next digit during digit or decimal point programming.
- Press or hold the Up arrow button to scroll through the menus, decimal point or press or hold to increment the value of a digit.
- Press the Enter button to access a menu or to accept a setting.
- Press and hold the Menu button for three seconds to access the advanced features of the controller.

## Controller Operation

The PD6310 accepts pulses (e.g.  $\pm 40\text{mV}$  to  $\pm 8\text{V}$ ), square wave (0-5, 0-12V, or 0-24V), open collector NPN, PNP, TTL, or switch contact signals.

These signals are scaled to represent rate in engineering units from -99999 to 999999. They may be scaled with a K-factor to represent a total for the batch, and grand total.

The default configuration displays batch total on the upper display, and a selection of rate, grand total, batch count, and preset on the lower display.

When in pause or stop mode, the display will alternate the numeric value with the run status in the upper display and the display label for the lower display.

The controller has up to 4 relays on board (and 4 available with an external expansion module) which are used to either control the batch process in single or multi-stage batch control, or as alarms that will be active when the batch process is running. A 4-20 mA output option is also available for retransmitting the process variable analog or pulse signal.

### Default Batch Control Operation

The following describes the operation of the three front panel operating keys as programmed with default settings.

#### START Button

Press the START button to begin a new batch process.

#### BATCH Button

Press the Batch button to access the Preset (batch amount) menu. Program the batch with the arrow keys, and confirm with the Enter key.

#### STOP Button

Press the STOP key once during a batch to pause. Press the STOP key while paused to stop and cancel the batch. Press the STOP key while in stop/ready mode cycle lower display values of rate (or other lower display programmed parameter), grand total, batch count, and preset.

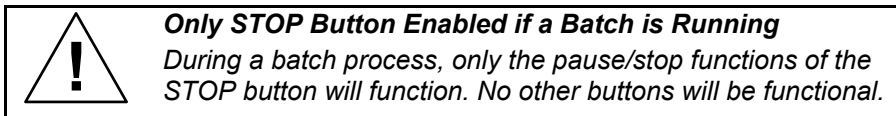

### Batch Control Operation Example

The following example shows how two stage batch control functions with a PD6310. This setup will establish a 55 gallon preset for the batch, with a main valve (high flow) that will close at 50 gallons, and a trickle valve (low or restricted flow) that will close at 55 gallons. After the batch, the preset will be changed to 100 gallons.

#### Two-Stage Batch Control Setup Using Relays 1 & 2

The following table shows the parameters as they appear within the *SEtUP* menu entry *rELAY*.

Parameter	Setting	Function
<i>rELAY</i>	<i>ASSIGN</i>	Press Enter to enter the relay assignment parameters.
<i>ASSIGN1</i>	<i>TOTAL</i>	Assign relay 1 to batch total control.
<i>ASSIGN2</i>	<i>TOTAL</i>	Assign relay 2 to batch total control.
<i>PRECLOSE TOTAL</i>		Press Enter to access preclose selection for multi-stage control.
<i>PRECLOSE</i>	<i>YES</i>	Yes to enable a preclose value for relay 2.
<i>YES</i>	<i>00005.0</i>	Set the preclose value to 5 for closing the valve controlling relay 2 five gallons before reaching the preset.
...		Assignment for optional relays 3-8.
<i>rLY 1 rELAY</i>		Select relay 1 setup.
<i>ACT 1 rLY 1</i>		Configure activation of relay 1.
<i>ACT 1</i>	<i>AUTO</i>	Always set to Auto for batch control function.
<i>rLY 1 PRESET</i>		Set the preset value for batch control.
<i>PRESET</i>	<i>00055.0</i>	Set 55 gallons as the preset.
...		Setup for optional relays 3-8.

The operation of relay 2 has already been assigned for multi-stage control preclose, and will not appear as a selection in the *rELAY* menu.

If only one stage batch control was desired, with one relay for control, then one would set the assignment of relay 2, *ASSIGN2*, to off, rate, or grand total.

The following pages show an illustration of how the above settings control the batch operation. The display assignment is the default.

#### Batch Control Operation

1. A new container is prepared for the batch. Both valves are closed. Note that display line 1 may show the batch total from the last batch.
2. The START button is pressed. Both valves open. The barrel begins to fill as the total being dispensed is displayed on line 1. Line 2 shows the rate and units, alternating.
3. When the batch total reaches 50 gallons, the preset (55) minus the preclose amount (5) for relay 2, relay 2 deactivates to close the main valve. The barrel fills more slowly as a result, improving accuracy.
4. When the batch total equals the preset, relay 1 deactivates, closing valve 1. Filling stops.
5. The BATCH button is pressed, and a new preset is entered, 100 gallons, and the enter/STOP button is pressed to confirm it.
6. The new batch begins when the START button is pressed, so both relays activate and both valves open.

#### Additional Features

At any time during the batch, the STOP button may be pressed to pause the batch. When paused, the START button will continue the batch, and pressing the STOP button again will cancel the batch.

When in STOP mode, the STOP button may be pressed to cycle through alternative parameters to be displayed on the lower display, including the grand total, batch count, and preset.

The grand total and batch count may be reset in the *rESET* menu by pressing the MENU button and entering the reset menu. It may also be reset with digital inputs.

## MANUAL MULTI-STAGE BATCH CONTROL OPERATION

### System Setup

- Both valves are closed with an empty barrel in place. The batched total is displayed in the upper display, the preset is selected for the lower display.



### Batch Start

- The START button is pressed, with both valves open. The barrel begins to fill.



### Preclose Valve

- When the batch total reaches a value of 50.00 (Preset[55.00] – Preclose[5.00]) the full-flow valve closes. The fill rate of the tank slows as a result.



### Completed Batch

- When the batch total equals the preset amount, the restricted-flow valve closes. The barrel is now full. If some overrun occurs, the next batch will adjust for this offset amount to maintain accuracy.

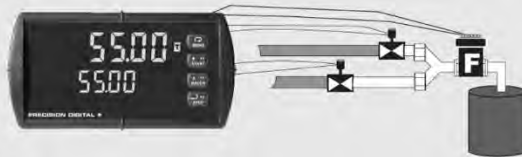

### Change Preset

- After placing a new, empty barrel, a new preset fill amount may be selected with the BATCH key, while the process is stopped.



### Begin New Batch

- Press the START key and a new batch will begin. With both valves open, the process continues.



### Pause/Stop

- At any time, the STOP button may be pressed, once to Pause the process, or twice to cancel the batch, which stops the process.



#### VALVE KEY LEGEND

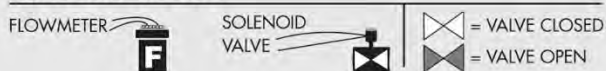

## MeterView® Pro Software

The meter can also be programmed using the PC-based MeterView Pro software included with the meter. This software can be installed on any Microsoft® Windows® (XP/Vista/7/8/10) computer by connecting the meter's onboard USB. The meter is powered by the USB connection, so there is no need to wire anything prior to programming the meter, though USB is intended only for meter configuration.

### MeterView Pro Installation

1. Connect one end of the provided USB cable to the meter and the other end to the computer. The computer will automatically install the driver software it needs to talk to the meter.

**Only one meter may be connected at a time. Attaching multiple meters will cause a conflict with the meter software.**

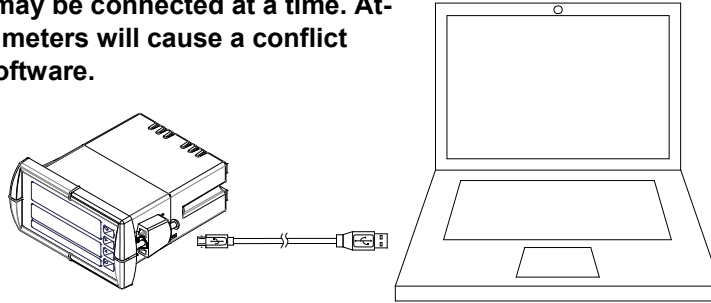

2. Once the driver is installed, an AutoPlay dialog should appear for the drive "MAINSTAL." Click "Open folder to view files." If the computer does not display an AutoPlay dialog for the drive "MAINSTAL," you should open My Computer and double-click on the drive labeled "MAINSTAL."



3. Double-click on the file named "MAStart." The program will open a few windows and install two programs on your computer. Simply follow the onscreen instructions until you see one of the dialogs below. If you receive a "User Account Control" warning, click "Yes."
4. If there is an update available, click the "Update" button to install the new version. Otherwise, click "Configure" to begin programming your meter.

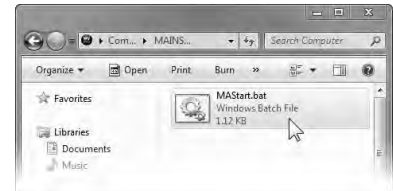

**Note:** If you decide to update your MeterView Pro software, once the installation has completed, you will be asked if you want to update the setup files located on the meter itself. This way, you will always have the most current version on the meter for future installs.



**Do not unplug the meter while the new installation files are being written to it. The meter will display  $\mu$ sr 1kE during the process and you will receive an onscreen notification once the process is complete.**

Data logging for one meter at a time is available with MeterView Pro software. More advanced data acquisition may be accomplished by using any Modbus RTU compliant software. Additional information regarding configuration and monitoring of the meter using MeterView Pro software is available online. Go to [www.predig.com/meterview-pro](http://www.predig.com/meterview-pro).

## Display Functions and Messages

The controller displays various functions and messages during setup, programming, and operation. The following table shows the main menu functions and messages in the order they appear in the menu.

Display	Parameter	Action/Setting Description	Display	Parameter	Action/Setting Description
SEtUP	Setup	Enter Setup menu	ḡt ḡb	Grand total time base	Program grand total time base
INPUt	Input	Enter Input selection menu	ḡt ḡF	Grand total conversion factor	Program grand total conversion factor
ḡoḡRL	Total	Enable or disable totalizer features	ḡt rSt	Grand total reset	Program grand total reset mode: auto or manual
un tS	Units	Select the display units/tags	dSPLRy	Display	Enter the Display menu
rRtE	Rate	Select the display units for rate	L nE 1	Display Line 1	Press Enter to assign the Upper display parameter (default: PV or rate)
ḡoḡRL	Total	Select the display units for total	L nE 2	Display Line 2	Press Enter to assign the Lower display parameter (default: total)
ḡḡoḡRL	Grand Total	Select the display units for grand total	d- nḡy	Display intensity	Set display intensity level from 1 to 8
dEc Pt	Decimal point	Set decimal point for rate, total, grand total	rELRy	Relay	Enter the Relay menu
PRoG	Program	Enter the Program menu	RSS ḡn	Assignment	Assign relays to rate, total (batch control), grand total, or Modbus controlled.
INḡRL	Input Calibration	Enter the Input Calibration menu	R5 ḡn 1	Assign 1	Relay 1-2 assignment
FRAḡoR	K-factor Scaling	Programs unit to convert input pulse to rate in engineering units	ḡoḡRL	Total	Assign relay to batch control
SCALE	Scale	Enter the Scale menu	ḡḡoḡRL	Grand total	Assign relay to grand total
ḡRL	Calibrate	Enter the Calibrate menu	nḡ bUS	Modbus	Assign relay to Modbus input
INP 1	Input 1	Calibrate input 1 signal or program input 1 value	rRtE	Rate	Assign relay to rate
dS 1	Display 1	Program display 1 value	PRḡcLS	Batch total relay preclose	For relays beyond the first assigned to total, a preclose amount may be entered.
INP 2	Input 2	Calibrate input 2 signal or program input 2 value (up to 32 points)	rLy 1	Relay 1	Relay 1 setup
dS 2	Display 2	Program display 2 value (up to 32 points)	Rḡt 1	Action 1	Set relay 1 action <sup>1</sup>
Error	Error	Error, calibration not successful, check signal or programmed value	Rḡḡo	Automatic	Set relay for automatic reset
ḡ ḡb	Total time base	Enter totalizer time base for seconds, minutes, hours or day.	R-nḡ Rn	Auto-manual <sup>1</sup>	Set relay for automatic & manual reset any time <sup>1</sup> (relays assigned to rate)
ḡ ḡF	Total conversion factor	Enter the conversion factor decimal point and the conversion factor.	LRLḡH	Latching <sup>1</sup>	Set relay for latching operation (relays assigned to rate) <sup>1</sup>
nḡ oḡE	Batch mode	Automatic or manual batch control			
ḡ dLy	Time delay	Set time delay for automatic batch restart			

Display	Parameter	Action/Setting Description
Lt-Clr	Latching-cleared <sup>1</sup>	Set relay for latching operation with manual reset only after alarm condition has cleared (relays assigned to rate) <sup>1</sup>
ALtErn	Alternate <sup>2</sup>	Set relay for pump alternation control (relays assigned to rate) <sup>2</sup>
SRn PL	Sampling	Set relay for sampling operation (rate or GT)
OFF	Off	Disable relay and front panel status LED (Select Off to enable Interlock feature)
PrESEt	Preset	Set batch preset
SEt 1	Set 1	Program set point 1
rSt 1	Reset 1	Program reset point 1
rLY 2	Relay 2	Relays 2-8 setup. Relays 5-8 are shown, only if expansion relay module is installed.
FRILSF	Fail-safe	Enter <i>Fail-safe</i> menu
FLS 1	Fail-safe 1	Set relay 1 fail-safe operation
on	On	Enable fail-safe operation
oFF	Fail-safe off	Disable fail-safe operation
dELAY	Delay	Enter relay <i>Time Delay</i> menu
dLY 1	Delay 1	Enter relay 1 time delay setup
On 1	On	Set relay 1 On time delay
OFF 1	Off	Set relay 1 Off time delay
brERH	Loop break	Set relay condition if loop break detected (For mA input only)
ignorE	Ignore	Ignore loop break condition (Processed as a low signal condition)
On	On	Relay goes to alarm condition when loop break is detected
OFF	Off	Relay goes to non-alarm condition when loop break is detected
Rout	Analog output	Enter the <i>Analog output</i> scaling menu

Display	Parameter	Action/Setting Description
d i s 1	Display 1	Program display 1 value
Out 1	Output 1	Program output 1 value (e.g. 4.000 mA)
d i s 2	Display 2	Program display 2 value
Out 2	Output 2	Program output 2 value (e.g. 20.000 mA)
rESEt	Reset	Press Enter to access the <i>Reset</i> menu
rSt Hi	Reset high	Press Enter to reset max display
rSt Lo	Reset low	Press Enter to reset min display
rSt HL	Reset high & low	Press Enter to reset max & min displays
rSt t	Reset total	Press Enter to reset total
rSt Gt	Reset grand total	Press Enter to reset grand total
rSt bc	Reset batch count	Press Enter to reset batch count
Control	Control	Enter <i>Control</i> menu
Auto	Automatic	Press Enter to set controller for automatic operation
Man	Manual	Press Enter to manually control relays or analog output operation
PASS	Password	Enter the <i>Password</i> menu
PASS 1	Password 1	Set or enter Password 1
PASS 2	Password 2	Set or enter Password 2
PASS 3	Password 3	Set or enter Password 3
total	Total password	Set or enter password for manual reset
Grand total	Grand total password	Set or enter password for manual reset
nonrSt	Non-resettable	Non-resettable grand total set after entering "050873" for Gtotal password
unLoc	Unlocked	Program password to lock controller
Locd	Locked	Enter password to unlock controller
999999 -999999	Flashing display	Overrange condition Underrange condition

1. During operation, only STOP button will function, to stop/pause the batch. As a result, relay alarms cannot be manually reset.

2. This setting is used for level control applications. It is not appropriate if using this controller for batching applications.

### Main Menu Map

The main menu consists of the most commonly used functions: *Setup*, *Reset*, *Control*, and *Password*.

- Press Menu button when a batch is not running to enter Programming Mode then press the Up arrow button to scroll main menu.
- Press Menu, at any time, to exit and return to Run Mode. Changes made to settings prior to pressing Enter are not saved.
- Changes to the settings are saved to memory only after pressing Enter.
- The display moves to the next menu every time a setting is accepted by pressing Enter.

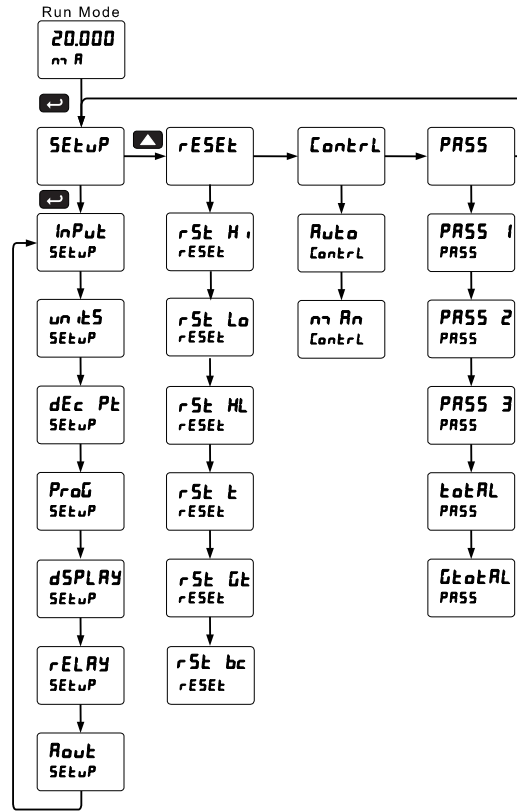

### Setting Numeric Values

The numeric values are set using the Right and Up arrow buttons. Press Right arrow to select next digit and Up arrow to increment digit value.

The digit being changed is displayed brighter than the rest.

Press and hold up arrow to auto-increment the display value.

Press the Enter button, at any time, to accept a setting or Menu button to exit without saving changes.

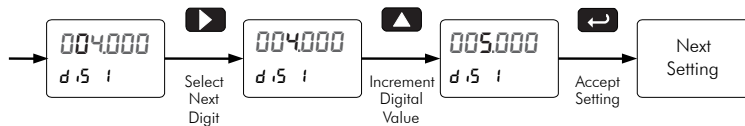



## Setting Up the Batch Controller (SEtUP)

The *Setup* menu is used to select:

1. Input signal the controller will accept
2. Enable or disable totalizer and batching features
3. Select the display units/tags
4. Decimal point position
5. Program menu for scaling or calibration
6. Display parameter and intensity
7. Relay operation
8. 4-20 mA analog output scaling

Press the Enter button to access any menu or press Up arrow button to scroll through choices. Press the Menu button to exit at any time.

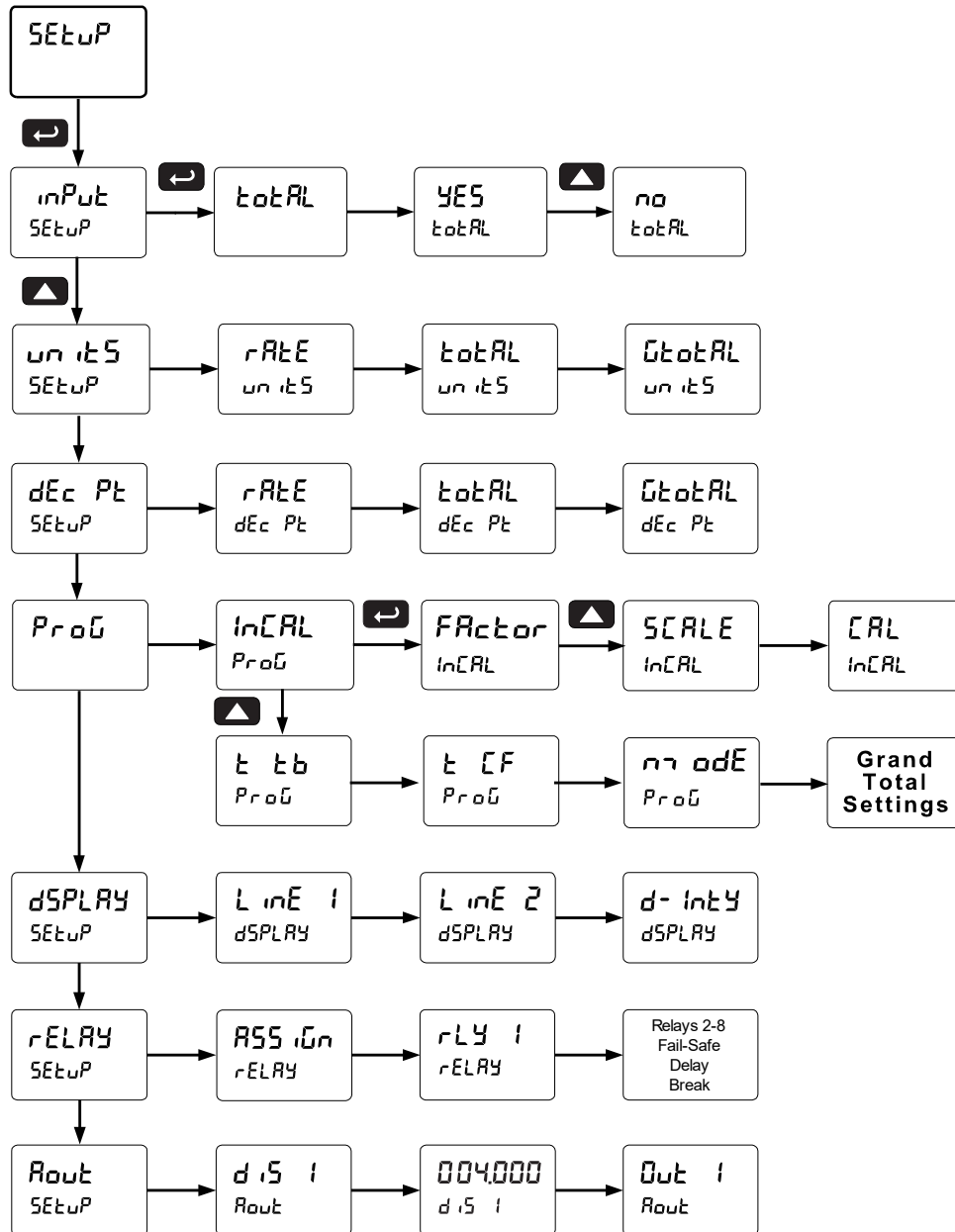

### Scaling and Calibration

It is very important to read the following information, before proceeding to program the controller:

- There is **no need to recalibrate** the controller when first received from the factory.
- All inputs are factory calibrated. The calibration equipment used is certified to NIST standards.
- Use the *Scale* menu to enter the scaling without a signal source.
- Use the *Calibrate* menu to apply a signal from a calibrator or a flowmeter for the scaling.

### Setting the Input Signal ( *InPUL* )

There is a switch, located to the right of the input connector, which must be configured according to the input level and type. Jumper J4 located inside the controller, behind the input signal connector, is used to select the excitation voltage (24 V (*Default setting*), 10 V or 5 V) which is supplied to the P+ and P- wiring terminals.

The controller may be calibrated using the *K-Factor* function. Most flowmeter manufacturers provide this information with the device. Enter the *K-Factor (FRCLDR)* menu and select the decimal point with highest resolution possible and program the K-factor value (*i.e.* pulses/gal). The controller will automatically calculate the flow rate using the K-factor and the time base selected.

### Setting the Totalizer and Batching Features ( *totRL* )

After the input type is entered, set the *totRL* parameter to “*YES*” to enable batch control (this is set by default). If the *totRL* features are disabled, most batching features and functions are hidden from the menus.

### Setting the Input Units or Custom Tags ( *unit5* )

Enter the input unit or custom tag that will be displayed if alternating rate, total, or grand total and units is selected in the *unit5* menu, or *d unit* is selected as the line 2 parameter. See the flow chart on page 31 to access the display menu to show the unit or tag on line 2. The engineering units or custom legends can be set using the following 7-segment character set:

Display	Character
0	0
1	1
2	2
3	3
4	4
5	5
6	6
7	7
8	8
9	9
A	A
b	b

Display	Character
C	C
c	c
d	d
E	E
F	F
G	G
g	g
H	H
h	h
I	I
i	i
J	J

Display	Character
K	K
L	L
m	m
n	n
O	O
o	o
P	P
q	q
r	r
S	S
t	t
u	u

Display	Character
v	V
w	w
X	X
Y	Y
Z	Z
-	-
/	/
[	]
]	[
=	=
Degree(<)	Degree(<)
Space	Space

Notes:

Degree symbol represented by (<) if programming with MeterView® Pro.

The letters “m” and “w” use two 7-segment LEDs each; when selected the characters to the right are shifted one position.

Press and hold up arrow to auto-scroll the characters in the display.

### Setting the Decimal Point (dEc Pt)

The decimal point may be set with up to five decimal places or with no decimal point at all. The rate, total, and grand total decimal points are independent.

Press the Up arrow to move the decimal point one place to the left. Press the Right arrow to move the decimal point one place to the right.

### Programming the Batch Controller (Prog)

It is **very important** to read the following information, before proceeding to program the controller:

- The PD6310 has been factory calibrated to read input frequency in Hz (pulses/sec). The calibration equipment is certified to NIST standards.
- Use the K-Factor in the menu to match the rate/totalizer with a flowmeter's k-factor (pulse/unit of measure).
- Use the *Scale* menu to scale process inputs without a signal source. A calibrated signal source is not needed to scale the controller.

The *Program* menu contains the following menus:

1. Enter K-Factor
2. Scale without a signal source
3. Calibrate with a calibrated signal source
4. Total time base & conversion factor
5. Grand total time base & conversion factor
6. Total reset mode for total & grand total

The process inputs may be calibrated or scaled to any display value within the range of the controller.

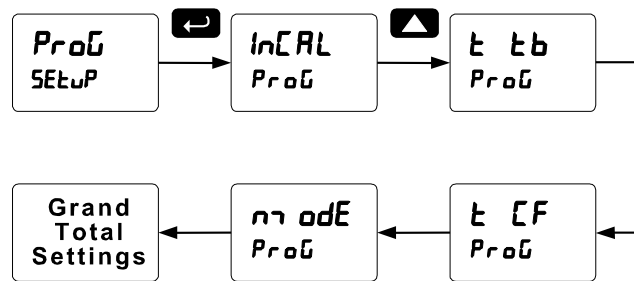

Additional parameters, not needed for most applications, are programmed in the *Advanced Features* menu; see *Advanced Operation and Programming* on page 42.

### Input Calibration Method (InCAL)

There are three methods of calibrating (or scaling) the display to show the correct engineering units.

- Use the *Factor* menu to enter a K-Factor. (Pulse input models only.)
- Use the *Scale* menu to enter the scaling without a signal source.
- Use the *Calibrate* menu to apply a signal from a signal source.

*Note: The K-Factor, Scale, and Calibrate functions are exclusive of each other. The meter uses the last function programmed. Only one of these methods can be employed at a time. The Scale and Calibrate functions can use up to 32 points (default is 2). The number of points should be set for Scale and Calibrate accordingly under the Number of Points (noPt5) menu selection prior to scaling and calibration of the meter, see page 46 for details.*

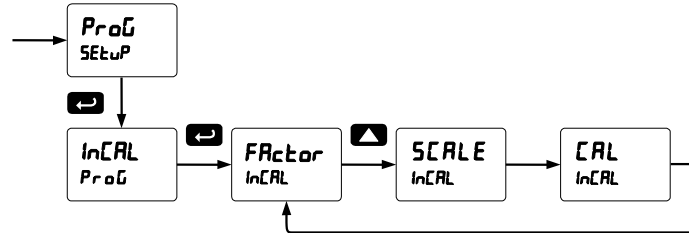

### K-Factor Calibration (FActor)

The meter may be calibrated using the *K-Factor* function. Most flowmeter manufacturers provide this information with the device. Enter the *K-Factor* (FActor) menu and select the decimal point with highest resolution possible and program the k-factor value (i.e. pulses/gal). The meter will automatically calculate the flow rate using the k-factor and the time base selected.



### Scaling the Controller (SCALE)

The process inputs (4-20 mA and  $\pm 10$  VDC) and frequency inputs can be scaled to display the process variable in engineering units.

A signal source is not needed to scale the controller; simply program the inputs and corresponding display values.

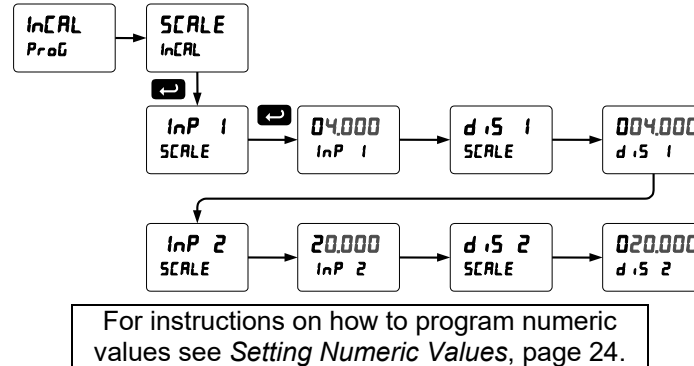

**Note:** The display values (d,5 1 and d,5 2) need to be in units of measure per second.

**For example:** If the rate at 1000 Hz is 13.2 gal/min, this must be converted to gal/sec. In this scenario, the numbers input into the SCALE menu would be as follows:

```
InP 1: 0.0
d,5 1: 0.000
InP 2: 1000.0
d,5 2: 0.220
```

Set the time base set to minutes (see below) and the meter will display 13.2 gal/min at 1000 Hz

### Error Message (Error)

An error message indicates that the calibration or scaling process was not successful.

After the error message is displayed, the controller reverts to input 2 during calibration or scaling and to input 1 during internal calibration, allowing the appropriate input signal to be applied or programmed.

The error message might be caused by any of the following conditions:

1. Input signal is not connected to the proper terminals or it is connected backwards.
2. Wrong signal selection in Setup menu.
3. Minimum input span requirements not maintained.
4. Input 1 signal inadvertently applied to calibrate input 2.

### Time Base, Total Conversion Factor & Total Reset

The time base, total conversion factor, and total reset menus are located in the Program menu.

The total and grand total have their own independent settings. This means that one can be displaying the value in gallons while the other displays in million gallons, liters, m<sup>3</sup>, etc.

#### Time Base

The time base is the amount of time over which the rate parameter should accrue. For example, if the rate was ten and the time base was in minutes, then the total would increase by ten every one minute.

#### Total & Grand Total Conversion Factor

The total & grand total conversion factor is the amount by which the rate is multiplied before it is added to the total or grand total. For Example, if the rate was ten per second and the total conversion factor was 100, the total would increase by 1000 every second. This is useful, for instance, if you want to show rate in gallons and total in thousands of gallons.

### Batch Start Mode (הר adE)

The batch controller may operate in manual or automatic mode. In manual mode, the controller operates as defined in Controller Operation as described on page 18. In automatic mode, the batch process will automatically begin after a completed batch. The time delay for the restart may be 0.1 to 999.9 seconds (ה dLY). Automatic batch start will only occur after a successful batch. A manually stopped batch will require a manual start to begin a new batch process.

### Grand Total Reset

The grand total can be programmed for manual or automatic reset. In the automatic reset mode, a programmable time delay is available to reset the grand total after the assigned preset is reached.

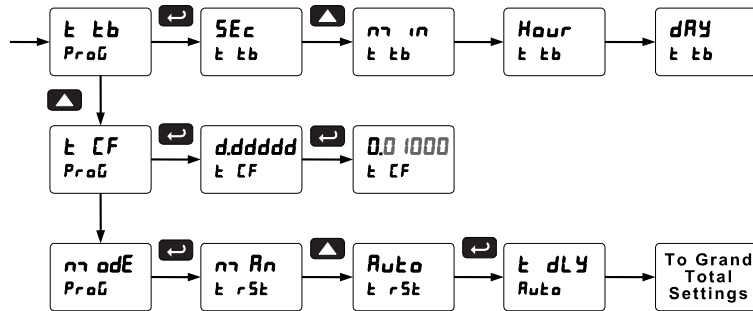

### Non-Resettable Totalizer

The total and grand total can be password-protected to prevent unauthorized resets. The grand total can be programmed as a non-resettable total, see page 41 for details.

### Calibrating the Controller with External Source (CAL)

To scale the controller without a signal source, refer to Scaling the Controller (SCALE) page 29.

The controller can be calibrated to display the process variable in engineering units by applying the appropriate input signal and the corresponding display value.

The use of a calibrated signal source is strongly recommended to calibrate the controller.

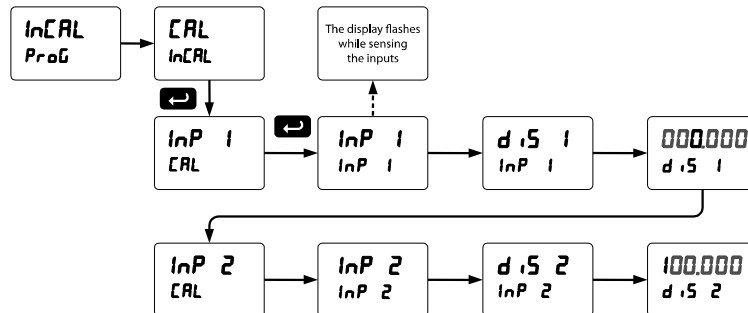

**Note:** The display values (d IS 1 and d IS 2) need to be in units of measure per second.

Warm up the controller for at least 15 minutes before performing calibration to ensure specified accuracy.

### Setting the Display Parameter & Intensity (dSPRAY)

Display line 1 (LINE 1) can be programmed to display:

1. Display total
2. Display grand total
3. Toggle rate and total
4. Toggle rate and grand total
5. Display batch count
6. Relay set points
7. Toggle preset and rate
8. Toggle rate and units
9. Toggle total and units
10. Toggle grand total and units
11. Display max and min values
12. Display Modbus input
13. Display rate value

Display line 2 (LINE 2) can be programmed to display:

1. Toggle rate and units
2. Toggle total and units
3. Toggle grand total and units
4. Display max and min values
5. Display Modbus input
6. Off (no display)
7. Display rate units
8. Display rate
9. Display total
10. Display grand total
11. Toggle rate and total
12. Toggle rate and grand total
13. Display batch count
14. Relay set points
15. Toggle preset and rate

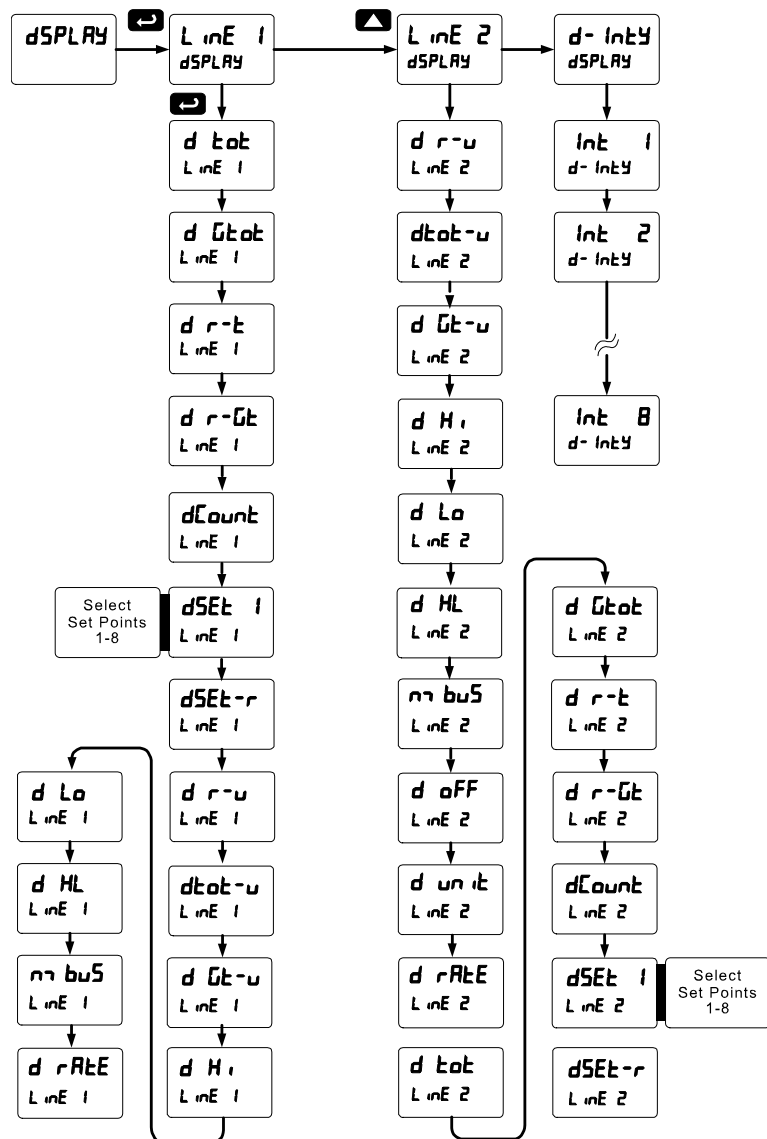

Display Intensity: The meter has eight display intensity levels to give the best performance under various lighting conditions. Select intensity 8 for outdoor applications. The default intensity setting is 8.

For direct sunlight readability, Sunbright display models are highly recommended. See Ordering Information on page 5 for details.

After setting up the input and the display, press the Menu button to exit programming and skip the rest of the setup menu. Press the Menu button again and the Up arrow to reach the *Program* menu and complete the scaling or calibration of the meter.

## Setting the Relay Operation (rELAY)

This menu is used to set up the operation of the relays.



**Caution!** *During setup, the relays do not follow the input and they will remain in the state found prior to entering the Relay menu.*

1. Relay assignment
  - a. Rate for low and high alarm
  - b. Total for batch control relays
  - c. Grand total for grand total alarms
2. Relay action
  - a. Automatic reset only (non-latching)
  - b. Automatic + manual reset when not in a batch process (non-latching)
  - c. Latching (manual reset when not in a batch process only)
  - d. Latching with Clear (manual reset when not in a batch process only after alarm condition has cleared)
  - e. Pump alternation control (automatic reset only, for level applications unrelated to batch control)
  - f. Sampling (the relay is activated for a user-specified time and may be assigned to rate or grand total)
  - g. Off (relay state controlled by Interlock feature)
3. Set and reset points; batch preset
4. Fail-safe operation
  - a. On (enabled)
  - b. Off (disabled)
5. Time delay
  - a. On delay (0-999.9 seconds)
  - b. Off delay (0-999.9 seconds)

*Note: Fail-safe should not be used for relays assigned to batch control.*



**Rate Alarms Only Active During a Batch Process**  
*The rate alarms are active only during a batch process. As a result, rate alarms should not be programmed with manual reset, as they cannot be manually reset during a batch process, the only time they are active.*

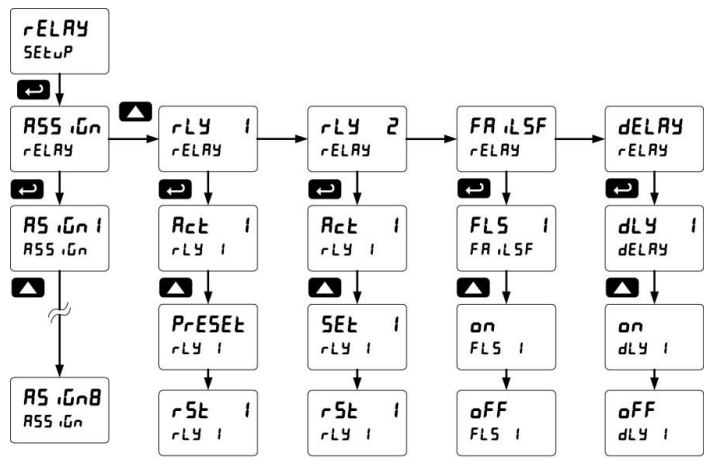

*Note: The setup of relays 3-8 follows the same pattern shown here for relay 2.*



## Relay Assignment (R55, Gn)

The relays can be assigned to any of the following parameters:

1. Rate for low or high alarm indication
2. Total for batch control relays
3. Grand total for alarm indication

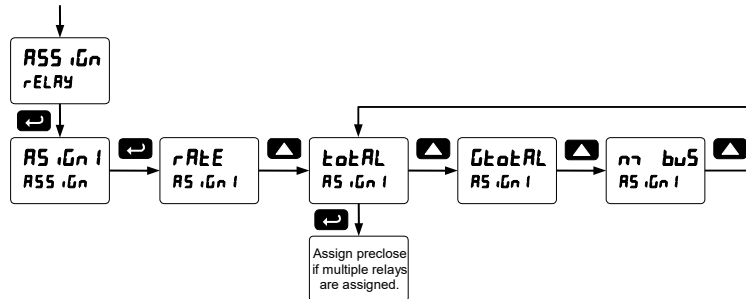

*Note: Relay 1 should always be assigned to “total” for batch control applications.*

## Setting the Relay Action

Operation of the relays is programmed in the *Action* menu. The relays are commonly set up for any of the following modes of operation:

1. Always set to Auto for Batch control operation. Also for automatic reset (non-latching) of alarms.
2. Sampling (the relay is activated for a user-specified time)
3. Off (relay state controlled by Interlock feature)

In addition, the following relay actions may be programmed. These actions are not appropriate for batch control applications, but may be used when the controller is in other applications.

4. Automatic + manual reset when not in a batch process (non-latching)
5. Latching (manual reset only, when not in a batch process)
6. Latching with Clear (manual reset only when not in a batch process after alarm condition has cleared)
7. Pump alternation control (automatic reset only, for level applications, unrelated to batch control.)

## Setting Batch Control Relays

Operation of batch control relays are programmed in the *Assign* menu by selecting *tOtAL* as the assignment. Relays set to *tOtAL* beyond the first will include a preclose parameter (*PrEcL5*) option. Selecting *YES* for *PrEcL5* will enable multi-stage batching with preclose, and the valve will close prior to the end of the batch at volume equal to the preset value minus the preclose amount entered. Selecting *no* for *PrEcL5* will have the relay perform identically to the first batch control relay set to *tOtAL*.

### Programming Alarm Set and Reset Points

High alarm indication: program set point above reset point.

Low alarm indication: program set point below reset point.

The deadband is determined by the difference between set and reset points. Minimum deadband is one display count. If the set and reset points are programmed with the same value, the relay will reset one count below the set point.

*Note: Changes are not saved until the reset point has been accepted.*

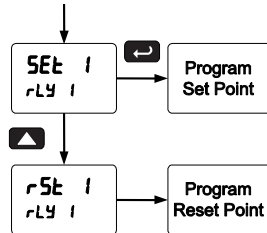

### Setting Fail-Safe Operation

In fail-safe mode of operation, the relay coil is energized when the process variable is within safe limits and the relay coil is de-energized when the alarm condition exists. The fail-safe operation is set independently for each relay. Select *on* to enable or select *off* to disable fail-safe operation. Failsafe mode should not be used on batch relays assigned to total.

### Programming Time Delay

The *On* and *Off* time delays may be programmed for each relay between 0 and 999.9 seconds. The relays will transfer only after the condition has been maintained for the corresponding time delay.

The *On* time delay is associated with the set point.

The *Off* time delay is associated with the reset point.

## Relay Operation Details

### Overview

The relays of the controller can serve three roles, as batch control relays for single or multi-stage batching, as rate, or grand total alarm, or as a sampling relay based on grand total or rate alarm.

These capabilities include front panel alarm status LEDs and 2 or 4 internal relays and/or 4 external relays expansion module.

The relays used for batch control (total) are activated when the batching process starts, and deactivate when the batch total is reached, minus any preclose amount programmed for batch (total) relays after the first.

For an example of batch control operation, see Batch Control Operation Example on page 19.

Typical applications for alarms are low and high flow alarms or grand total limit alarms. Note that rate alarms are only enabled during a batching process, and deactivate when the processes is stopped.

The relays can also be set for sampling, where the relay will activate for a specific amount of time after a certain grand total has been reached (ie: 2 second sample relay activation every 100 gallons batched).

There are three basic ways the relays can be used:

1. Batch Control (Total)
2. High or Low Alarms for Rate or Grand Total
3. Sampling (Based on Grand Total and Sample Time)

### Relays Initialization

Batch control (total) relays will activate when the start function is enabled, such as when the START button is pressed. Rate alarm relays will enable and initialize to their programmed states when the batch process is started. Grand total alarm relays will initialize to their programmed state at controller power-up.

### Fail-Safe Operation

The following table indicates how alarm relays behave based on the fail-safe selection for each relay:

*Note: NO = Normally Open, NC = Normally Closed. This refers to the condition of the relay contacts when the power to the controller is off.*

Fail-Safe Selection	De-Energized State		Energized State		Power Failure
	NO	NC	NO	NC	
Off	Open	Closed	Closed	Open	Relays in de-energized state
On	Closed	Open	Open	Closed	Relays in energized state

### Front Panel LEDs

The LEDs on the front panel provide status indication for the following:

The controller is supplied with four alarm points that include front panel LEDs to indicate alarm conditions. This standard feature is particularly useful for alarm applications that require visual-only indication. The LEDs are controlled by the set and reset points programmed by the user. When the display reaches a set point for a high or low alarm, the corresponding alarm LED will turn on. When the display returns to the reset point the LED will go off. Note that rate alarms are only enabled during a batching process, and deactivate when the processes are stopped.

LED	Status
1	Alarm 1
2	Alarm 2
3	Alarm 3
4	Alarm 4

LED	Status
5	Alarm 5
6	Alarm 6
7	Alarm 7
8	Alarm 8

Latching relays, or relays with manual reset, are not recommended when using this controller for batch control, as the manual reset will not be acknowledged during a batch process, when the rate alarms are active. For information on latching and manual reset alarms, see the PD6200 and PD6300 instruction manuals available at [www.predig.com](http://www.predig.com).

### Automatic Reset (Auto)

In this application, the controller is set up for automatic reset (non-latching relay). Acknowledging the alarm while it is still present has no effect on either the LED or the relay. When the alarm finally goes away, the relay automatically resets and the LED also goes off.

Automatic reset only		
Condition	LED	Relay
Normal	Off	Off
Alarm	On	On
Ack (No effect)	On	On
Normal	Off	Off

### Pump Alternation Control

Pump alternation control is not recommended when using this controller for batch control, as it is used only in level applications, and not with rate, total, or batching applications. For information on using pump alternation control for level, see the PD6200 and PD6300 instruction manuals available at [www.predig.com](http://www.predig.com).

### Setting Up the Interlock Relay (Force On) Feature

Relays 1-4 can be set up as interlock relays. To set up the relays for the interlock feature:

1. Access the *Setup – Relay – Action* menu and set the action to off.

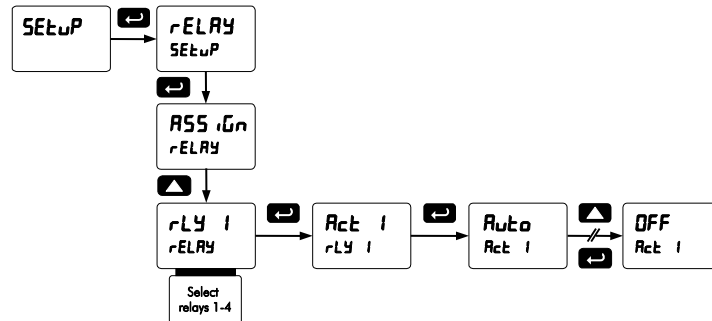

2. In the Advanced features – *User* menu program any of the digital inputs to Force On any of the internal relays (1-4).

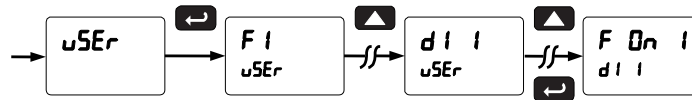

3. Connect a switch or dry contact between the +5V terminal and the corresponding digital input (dl-1 to dl-4) terminal.

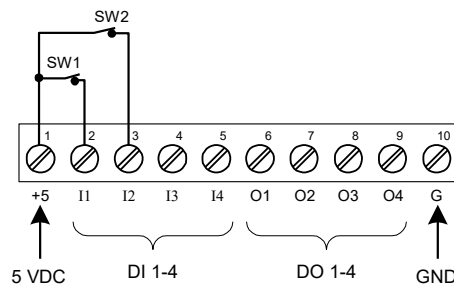

### Interlock Relay Operation Example

Relays 3 & 4 are configured to energize (their front panel LEDs are off) when SW1 & SW2 switches (above) are closed. If the contacts to these digital inputs are opened, the corresponding front panel LEDs flash indicating this condition. The processes being controlled by the interlock relay will stop, and will restart only after the interlock relay is re-activated by the digital inputs (switches).

### Sample Relay Operation

The sampling function allows the operator to set a set point for a “sampling” relay. This can be done for the rate, total, or grand total. Each time the relay reaches the set point, it will close that relay’s contacts for a programmed period of time

A rate sampling relay will activate for the sample time (5MIN T), up to 600.0 seconds, every time the set point rate is reached.

A total sampling relay will activate for the sample time (5MIN T), up to 600.0 seconds every time the process has batched the amount programmed for the set point, and every time this amount has been batched afterward. (See the diagram below for more details). The utility of this function can, of course, be expanded beyond sampling and be used whenever a timed relay output closure is required when the batch total interval reaches a certain set point.

### Relay and Alarm Operation Diagrams

The following graphs illustrate the common operation of the relays, status LEDs, and ACK button.

**High Alarm Operation (Set > Reset)**

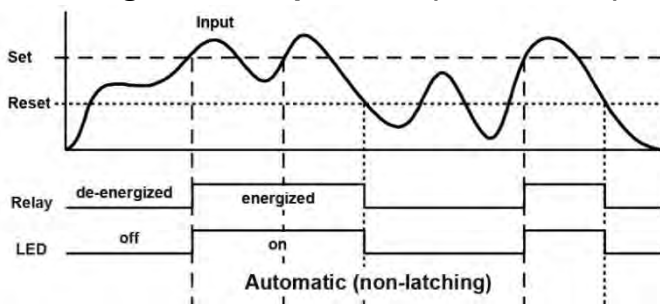

**Low Alarm Operation (Set < Reset)**

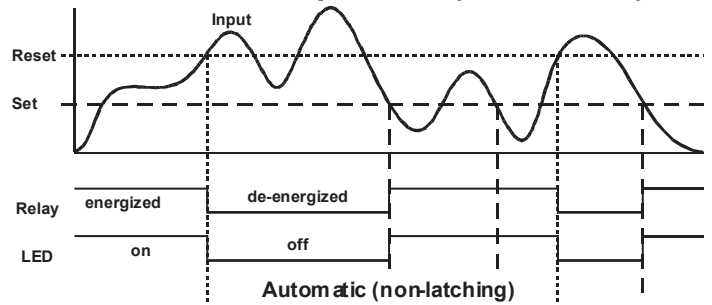

**High Alarm with Fail-Safe Operation (Set > Reset)**

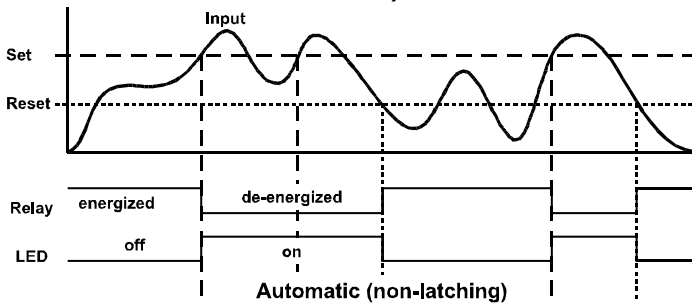

**Low Alarm with Fail-Safe Operation (Set < Reset)**

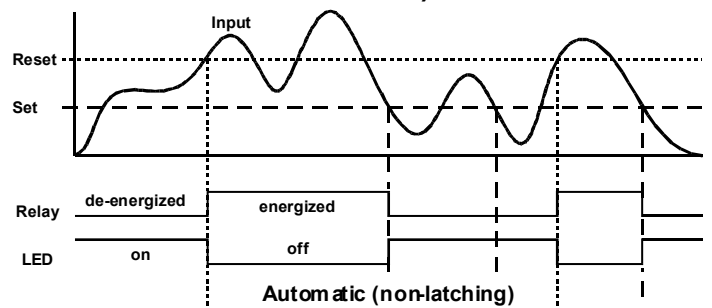

*Note: Relay coil is energized in non-alarm condition. In case of power failure, relay will go to alarm state.*

*Note: Relay coil is energized in non-alarm condition. In case of power failure, relay will go to alarm state.*

### Rate Relay Sampling Operation

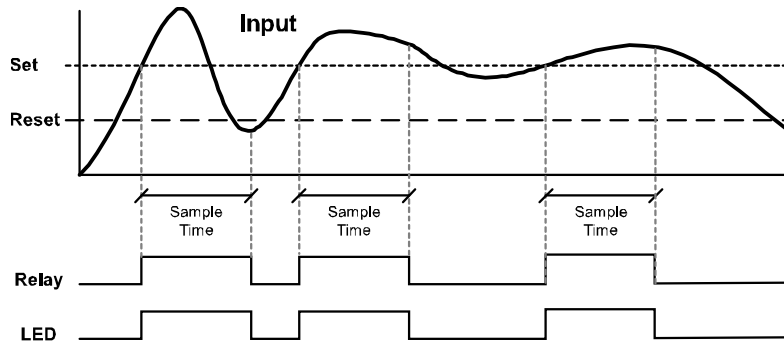

When the signal crosses the set point, the relay trips and the sample time starts. After the sample time has elapsed, the relay resets. The cycle repeats every time the set point is crossed, going up for high alarms and going down for low alarms.

The sample time can be programmed between 0.1 and 600.0 seconds.

### Total Relay Sampling Operation

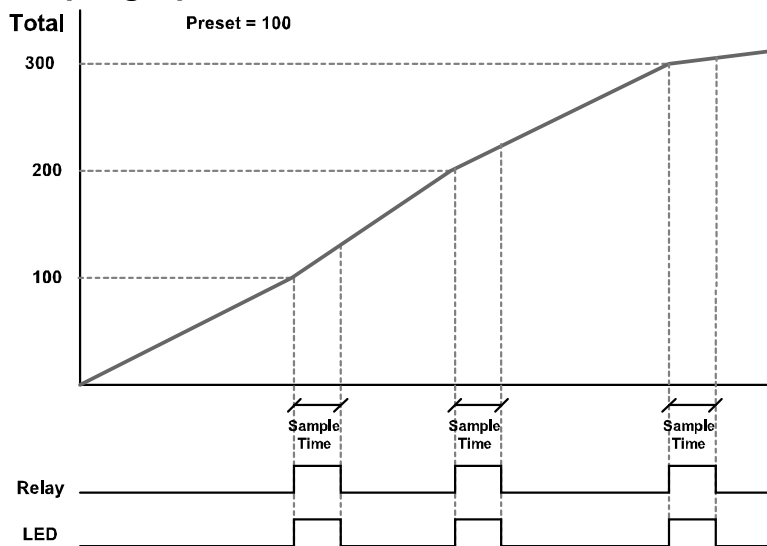

When the batch total reaches the set point, the relay trips and the sample time starts. After the sample time has elapsed, the relay resets. The cycle repeats every time the set point value is added to the batch total.

### Time Delay Operation

The following graphs show the operation of the time delay function.

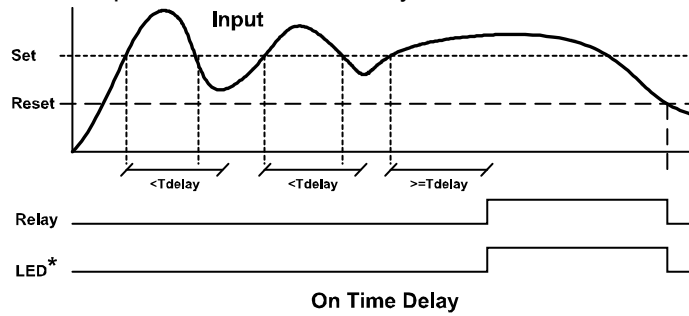

On Time Delay

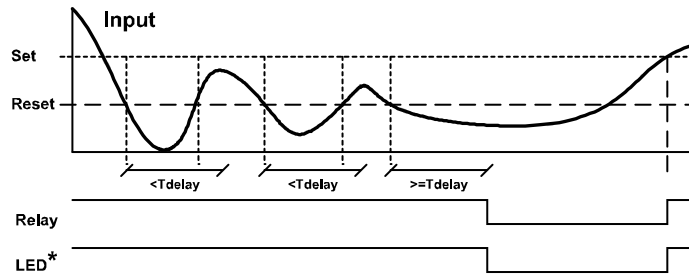

Off Time Delay

When the signal crosses the set point, the *On* time delay timer starts and the relay trips when the time delay has elapsed. If the signal drops below the set point (high alarm) before the time delay has elapsed, the *On* time delay timer resets and the relay does not change state. The same principle applies to the *Off* time delay.

*Note: If "Automatic or Manual (R-nn Rn)" reset mode is selected, the LED follows the reset point and not the relay state when the relay is acknowledged.*

### Scaling the 4-20 mA Analog Output (Rout)

The 4-20 mA analog output can be scaled to provide a 4-20 mA signal for any rate display range selected.

No equipment is needed to scale the analog output; simply program the display values to the corresponding mA output signal.

The *Analog Output* menu is used to program the 4-20 mA output based on rate display values.

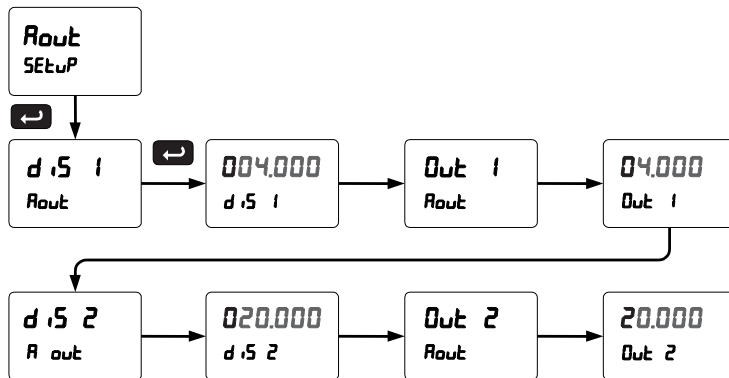

For instructions on how to program numeric values see *Setting Numeric Values*, page 24.

## Reset Menu (rESEt)

The *Reset* menu is used to reset the total, grand totals, batch count, maximum, or minimum reading (peak or valley) reached by the process; both maximum and minimum may be reset at the same time by selecting “reset high & low” (rSEt HL).

## Control Menu (ContrL)

The *Control* menu is used to control the 4-20 mA analog output and the relays manually, ignoring the input. Each relay and analog output can be programmed independently for manual control. Selecting automatic control sets all relays and analog output for automatic operation.

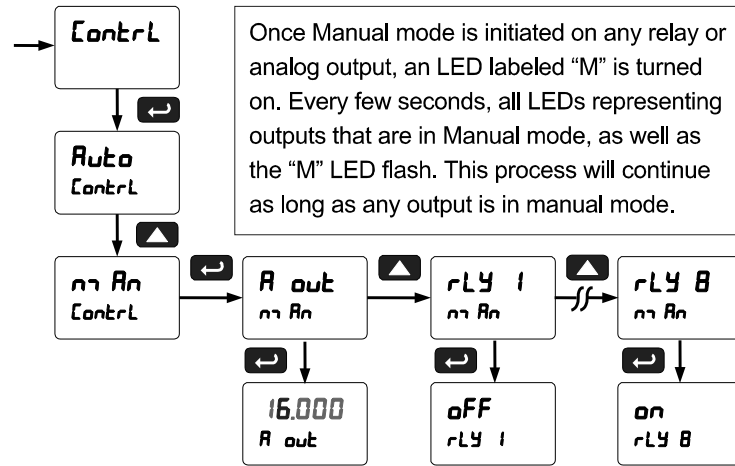

## Setting Up the Password (PASS)

The *Password* menu is used for programming three levels of security to prevent unauthorized changes to the programmed parameter settings and to program the non-resettable totalizer.

Pass 1: Allows use of function keys and digital inputs  
 Pass 2: Allows use of function keys, digital inputs and editing set/reset points  
 Pass 3: Restricts all programming, function keys, and digital inputs.  
 Total Password: Prevents resetting the total manually  
 Gtotal Password: Prevents resetting the grand total manually

### Protecting or Locking the Controller

Enter the *Password* menu and program a six-digit password.

For instructions on how to program numeric values see *Setting Numeric Values*, page 24.

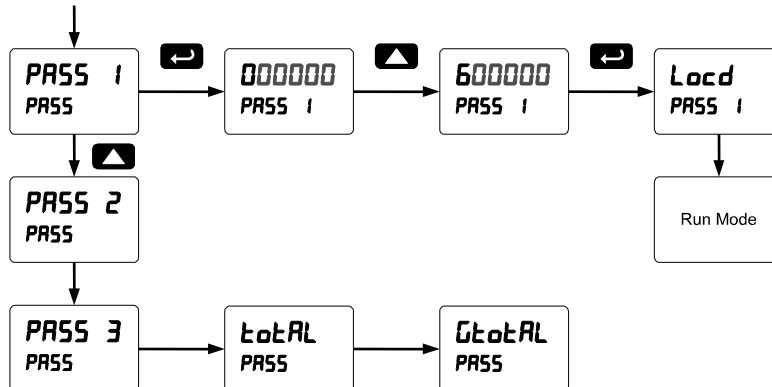



### Grand Total Reset Password & Non-Resettable Total

The grand total can be password-protected to prevent unauthorized total resets. The grand total can be programmed as a non-resettable total by entering the password “050873”.



**Caution!** Once the Grand Total has been programmed as “non-resettable” the feature **cannot** be disabled.

### Making Changes to a Password Protected Controller

If the controller is password protected, the controller will display the message *Locd* (Locked) when the Menu button is pressed. Press the Enter button while the message is being displayed and enter the correct password to gain access the menu. After exiting the programming mode, the controller returns to its password protected condition.

### Disabling Password Protection

To disable the password protection, access the *Password* menu and enter the correct password twice, as shown below. The controller is now unprotected until a new password is entered.

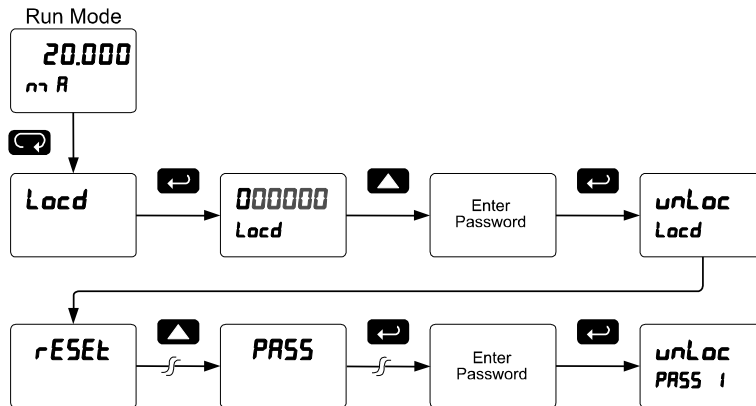

If the correct six-digit password is entered, the controller displays the message *unLoc* (unlocked) and the protection is disabled until a new password is programmed.

If the password entered is incorrect, the controller displays the message *Locd* (Locked) for about two seconds, and then it returns to Run Mode. To try again, press Enter while the *Locked* message is displayed.

**Did you forget the password?**

The password may be disabled by entering a master password once. If you are authorized to make changes, enter the master password 508655 to unlock the controller.

## Advanced Operation and Programming

In addition to the functions described in Controller Operation on page 18, the following advanced operation and display features may be programmed. Configuring these features may disable some default batch controller features, or make running a batch operation impossible. These functions should only be used by users who are sure of their need in their application.

### Advanced Features Menu

To simplify the setup process, functions not needed for most applications are located in the *Advanced Features* menu.

Press and hold the Menu button for three seconds to access the advanced features of the controller. This cannot be done during a back process as all functions other than STOP are disabled during a batch process, including the Menu button.

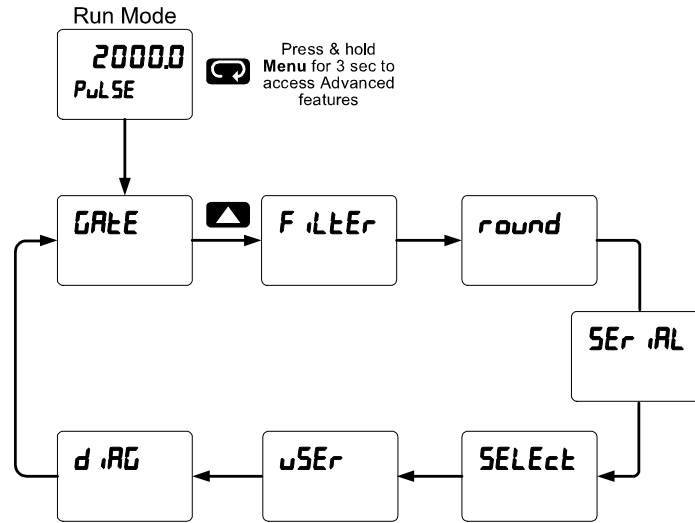

### Advanced Features Menu & Display Messages

The following table shows the functions and messages of the *Advanced Features* menu in the order they appear in the menu.

Display	Parameter	Action/Setting
GATE	Gate	Gate settings
Lo G	Low gate	Program Low gate value
Hi G	High gate	Program High gate value
FILTER	Filter	Set noise filter value
Hi SPD	High Speed Filter	Program High Speed Filter
Lo SPD	Low Speed Filter	Program Low Speed Filter
round	Round	Set the rounding value for display variables
SERIAL	Serial	Set serial communication parameters
SLAVE ID	Slave ID	Set slave ID or controller address
baud	Baud rate	Select baud rate
tr dLY	Transmit delay	Set transmit delay for serial communication

Display	Parameter	Action/Setting
PRR tLY	Parity	Select parity Even, Odd, or None with 1 or 2 stop bits
t-bYTE	Time byte	Set byte-to-byte timeout
SELEct	Select	Enter the Select menu (function, cutoff, out)
FuncTn	Signal Input Conditioning	Select linear, square root, or programmable exponent
LinERr	Linear	Set controller for linear function and select number of linearization points
no Pts	Number of points	Set controller for 2 to 32-point linearization
Cutoff	Cutoff	Set low-flow cutoff
Count	Count	Set the totals to count up or down from a set value

Display	Parameter	Action/Setting
ጅዕቲ ፭	<i>Total count</i>	Set the batch to count up to or down from the preset
ሆፕ	<i>Up</i>	Set the total to count up
ድሙጎጎ	<i>Down</i>	Set the total to count down
፩ጅዕቲ ፭	<i>Grand total count</i>	Set the grand total to count up or down from a defined value
፭ ናይጉጅ	<i>Count start</i>	Set the starting grand total value when counting down
የዕድገት	<i>Analog output programming</i>	Program analog output parameters
ናዕድገት	<i>Source</i>	Select source for the 4-20 mA output
ሆ-ገገጎጎ	<i>Overrange</i>	Program mA output for display overrange
ሆ-ገገጎጎ	<i>Underrange</i>	Program mA output for display underrange
ፑዕገገጎ	<i>Force output</i>	Force analog output value for loop break
፩ጎጎጎጎ	<i>Ignore</i>	Ignore loop break condition
ጎጎጎጎ	<i>Maximum</i>	Program maximum mA output allowed
ጎጎጎጎ	<i>Minimum</i>	Program minimum mA output allowed
፭ገገጎጎ	<i>Calibrate</i>	Calibrate 4-20 mA output (internal reference source used for scaling the output)

Display	Parameter	Action/Setting
4 ጎጎጎ	<i>4 mA output</i>	Enter mA output value read by milliamp meter with at least 0.001 mA resolution
20 ጎጎጎ	<i>20 mA output</i>	Enter mA output value read by milliamp meter with at least 0.001 mA resolution
ሆ5፭ገ	<i>User I/O</i>	Assign function keys and digital I/O
F 1	<i>F1 function key</i>	Assign F1 function key
F 2	<i>F2 function key</i>	Assign F2 function key
F 3	<i>F3 function key</i>	Assign F3 function key
F 4	<i>F4 function</i>	Assign F4 function (digital input)
ደ 1 1	<i>Digital input 1</i>	Assign digital input 1 – 8, if expansion modules are connected
ደ 0 1	<i>Digital output 1</i>	Assign digital output 1 – 8, if expansion modules are connected
ደ ገገጎ	<i>Diagnostics</i>	Display parameter settings
፭፭፭ ጅ	<i>LED test</i>	Test all LEDs
ጎጎፑ	<i>Information</i>	Display software information
፭ገገ5፭	<i>Erase</i>	Erase MeterView Pro software stored in meter's memory

### Function Keys Operation

During operation, the programmable function keys operate according to the way they have been programmed in the *Advanced Features – User* menu. The following table shows the default setting for each of the function keys.

Function Key/Button	Default Setting	Action
F1/START	StArT	Start batch
F2/BATCH	PrESEt	Change preset
F3/STOP	StoP	Pause/stop batch
F4/Digital Input	StStP	Start/stop batch

### F4 Operation

A digital input, F4, is standard on the meter. This digital input is programmed identically to function keys F1, F2, and F3. The input is triggered with a contact closure to COM, or with an active low signal. During operation, F4 operates according to the way it has been programmed in the *Advanced Features – User* menu.



**Only STOP Operation Enabled if a Batch is Running.**  
 During a batch process, the only function that can be performed is the pause/stop functions of the STOP button; the default programming of the F3 key. No other functions, including min/max display, manual alarm reset, or total reset, will function while a batch is running.

### Multi-Point Calibration & Scaling

The controller is set up at the factory for 2-point linear calibration. The number of points for multi-point calibration/scaling is set up in the *Advanced Features* menu. Up to 32 linearization points may be selected. See page 46 for details.

### Maximum/Minimum Readings

The max & min readings (peak & valley) reached by the process can be displayed either continuously or momentary:

1. Display briefly by assigning to the digital inputs in the *User* menu.
2. Display continuously by assigning either display to max/min through the *Display* menu.





Changing the programming of the F1-F3 function keys will disable the default batch operation of these keys, and is not recommended for batch control applications.

Any of the digital inputs can be programmed to reset the max & min readings.

#### To display max/min readings continuously:

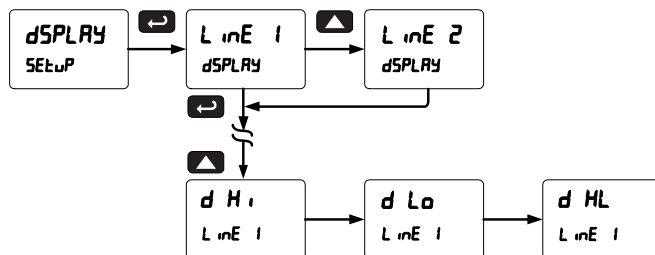
Assign either display to Max (d H i), Min (d Lo), or toggle between Max and Min (d HL) every 10 seconds.





Note that changing default the programming of the upper or lower displays will interfere with seeing the batch total (upper display) or rate (lower display) of the batch process.

### Noise Filter (*FILTER*)

The noise filter is available for unusually noisy signals that cause an unstable process variable display. The noise filter averages the input signal over a certain period. The filter level determines the length of time over which the signal is averaged. There are two available settings: Hi Speed and Lo Speed (programmable from 2 to 50).

### Noise Filter Bypass (*BYPASS*)

The noise filter bypass changes the behavior of the controller so that small variations in the signal are filtered out but large abrupt changes in the input signal are displayed immediately. The bypass value determines the minimum amount of signal change to be displayed immediately. All signal changes smaller than the bypass value are filtered or averaged by the controller. The noise filter bypass may be set between 0.1 and 99.9% of full scale.

### Rounding Feature (*round*)

The rounding feature is used to give the user a steadier display with fluctuating signals. Rounding is used in addition to the filter function.

Rounding causes the display to round to the nearest value according to the rounding selected. This setting affects the last two digits, regardless of decimal point position.

### Modbus RTU Serial Communications (*SERIAL*)

The controller is equipped with serial communications capability as a standard feature using Modbus RTU Serial Communication Protocol.

The meter may be connected to a PC for initial configuration via the onboard micro USB connection. For ongoing digital communications with a computer or other data terminal equipment, an RS-232, or RS-485 option is required; see *Ordering Information* on page 5 for details.



**Warning!** *Do not connect any equipment other than Precision Digital's expansion modules, cables, or controllers to the RJ45 M-LINK connector. Otherwise damage will occur to the equipment and the controller.*

*Note: More detailed instructions are provided with each optional serial communications adapter. Note: Refer to the ProVu® Modbus Register Tables located at [www.predig.com](http://www.predig.com) for details.*

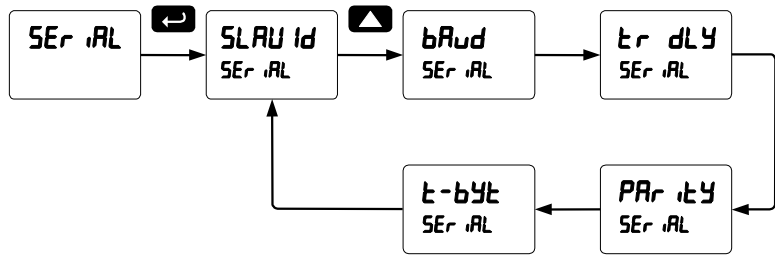

When using more than one controller in a multi-drop mode, each controller must be provided with its own unique address. The controller address (Slave ID) may be programmed between 1 and 247. The transmit delay may be set between 0 and 199 ms. The parity can be set to even, odd, or none with 1 or 2 stop bits.

### Select Menu (SELEct)

The *Select* menu is used to select the signal input conditioning applied to the input (linear, square root, or programmable exponent, low-flow cutoff, and analog output programming. The multi-point linearization is part of the linear function selection.

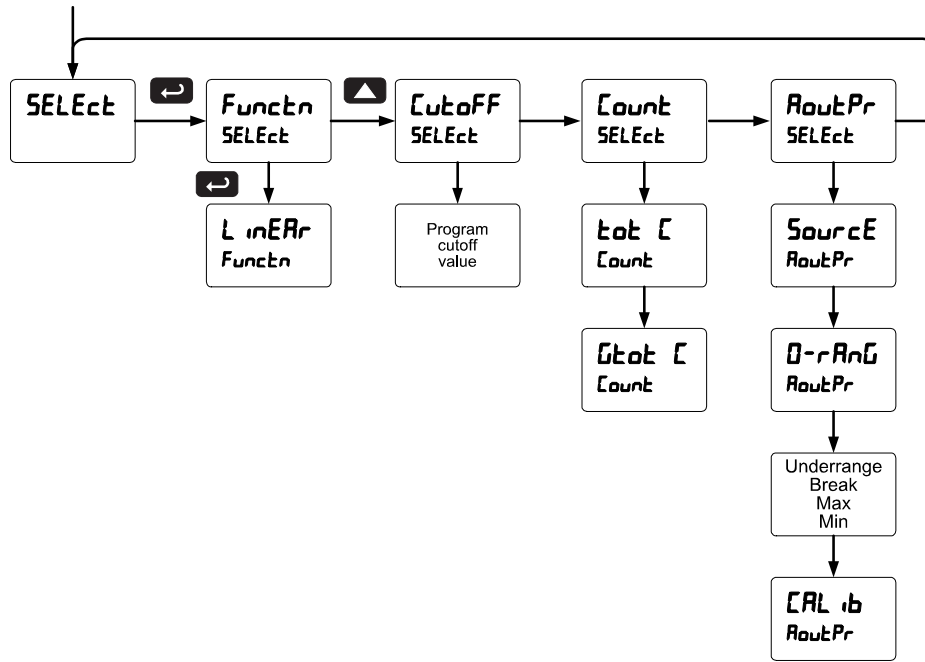

### Signal Conditioning Selection (Functn)

The *Function* menu is used to select the signal conditioning function applied to the input: linear, square root, or programmable exponent. The multi-point linearization is part of the linear function selection. Controllers are set up at the factory for linear function with 2-point linearization. The linear function provides a display that is linear with respect to the input signal.

### Multi-Point Linearization (L inERr)

Controllers are set up at the factory for linear function with 2-point linearization. Up to 32 linearization points can be selected under the linear function. The multi-point linearization can be used to linearize the display for non-linear signals such as those from level transmitters used to measure volume in odd-shaped tanks or to convert level to flow using weirs and flumes with complex exponent.

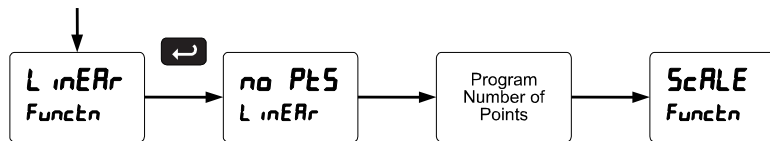

### Low-Flow Cutoff (Cutoff)

The low-flow cutoff feature allows the controller to be programmed so that the often-unsteady output from a differential pressure transmitter, at low flow rates, always displays zero on the controller.

The cutoff value may be programmed from 0 to 999999. The controller will display zero below the cutoff value. Programming the cutoff value to zero disables the cutoff feature.

### Total and Grand Total Count Direction (Count)

By default, the batch total and grand total count up during batch processes. Count parameter allows this to change. When set to count down, the batch total will count down from the preset to 0. When set to count down, the grand total will count down from a set value to zero.

### Analog Output Programming (RoutPr)

The *Analog Output Programming* menu is used to program the behavior of the 4-20 mA output. The following parameters and functions are programmed in this menu:

1. Source: Source for generating the 4-20 mA output (e.g. PV)
2. Overrange: Analog output value with display in overrange condition
3. Underrange: Analog output value with display in underrange condition
4. Break: Analog output value when loop break is detected
5. Max: Maximum analog output value allowed regardless of input
6. Min: Minimum analog output value allowed regardless of input
7. Calibrate: Calibrate the internal 4-20 mA source reference used to scale the 4-20 mA output

### Analog Output Source

The source for generating the 4-20 mA output may be assigned to the rate/process variable, total, grand total, maximum or minimum value reached by the rate/process, one of the set points, or the Modbus PV input.

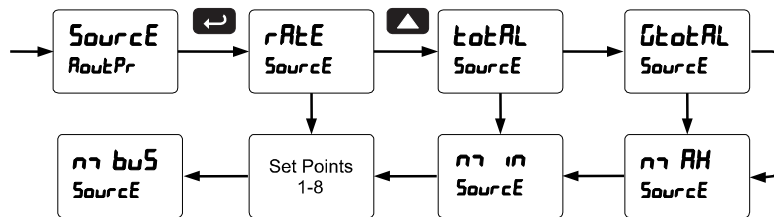

### Analog Output Calibration

To perform the analog output calibration, it's recommended to use a milliamp meter with a resolution of at least 0.1  $\mu$ A to measure the output current. The values saved internally during this procedure are used for scaling the 4-20 mA output in the *Setup* menu.

### Programmable Function Keys User Menu (uSEr)



*Changing the programming of the F1-F3 function keys will disable the default batch operation of these keys, and is not recommended for batch control applications.*

The *User* menu allows the user to assign the front panel function keys F1, F2, and F3, the digital input F4 (a digital input located on the signal input connector), and up to eight additional digital inputs to access most of the menus or to activate certain functions immediately (e.g. reset max & min, hold relay states, etc.). This allows the meter to be greatly customized for use in specialized applications.

Up to eight digital outputs can be assigned to a number of actions and functions executed by the meter (i.e. alarms, relay acknowledgement, reset max, min, or max & min, tare, and reset tare). The digital outputs can be used to trigger external alarms or lights to indicate these specific events.

**Function Keys & Digital I/O Available Settings**

Refer to the following table for descriptions of each available function key or digital I/O setting.

Display	Description	Display	Description
5tRrŁ	Starts the batch process	d 5RbŁ	Disable the selected function key or digital I/O
5tŁP	Stops the batch process	RcH	Acknowledge all active relays that are in a manual operation mode such as auto-manual or latching
5rŁ5ŁP	Allows the same function key to both start and stop the batch process	rŁŁŁŁ	Directly access the reset menu
rŁY d	Disable all relays until a button assigned to <i>enable relays</i> (rŁY Ł) is pressed	rŁŁ Ł	Reset the total
rŁY Ł	Enable all relays to function as they have been programmed	rŁŁ ŁŁ	Reset the grand total
Ł ŁŁŁ	Hold current relay states and analog output as they are until a button assigned to <i>enable relays</i> (rŁY Ł) is pressed	rŁŁ bŁ	Reset the batch count
d ŁŁŁ	Hold the current display value, relay states, and analog output momentarily while the function key or digital input is active. The process value will continue to be calculated in the background.	rŁŁ H Ł	Reset the maximum display value
ŁŁ Ł Ł	Display maximum display value on line 1	rŁŁ ŁŁ	Reset the minimum display value
ŁŁ Ł ŁŁ	Display minimum display value on line 1	rŁŁ ŁŁ	Reset the maximum & minimum display values
ŁŁ Ł ŁŁ	Display maximum & minimum display values on line 1	rŁŁRŁY	Directly access the relay menu
ŁŁŁ Ł Ł	Display maximum display value on line 2	PŁŁŁŁŁ	Change the preset value
ŁŁŁ ŁŁ	Display minimum display value on line 2	5ŁŁ Ł*	Directly access the set point menu for relay 2 (*through 8)
ŁŁŁ ŁŁ	Display maximum & minimum display values on line 2	ŁŁŁŁŁ	Mimic the menu button functionality (digital inputs only)
ŁŁŁ ŁŁ	Display the grand total on line 2	r ŁŁŁŁ	Mimic the right arrow/F1 button functionality (digital inputs only)
ŁŁŁ bŁ	Display the batch count on line 2	ŁP	Mimic the up arrow/F2 button functionality (digital inputs only)
ŁŁŁŁŁ	Directly access the control menu	ŁŁŁŁŁ	Mimic the enter/F3 button functionality (digital inputs only)
		F ŁŁ Ł*	Force relay 1 (*through 4) into the on state. This function is used in conjunction with a digital input expansion module to achieve interlock functionality. See page 36 for details about interlock relays.
		RŁŁ Ł*	Provide indication when alarm 1 (*through 8) has been triggered (digital outputs only)



## Troubleshooting

Due to the many features and functions of the controller, it's possible that the setup of the controller does not agree with what an operator expects to see.

If the controller is not working as expected, refer to the *Diagnostics* menu and recommendations below.

### Diagnostics Menu (d iRG)

The *Diagnostics* menu is located in the *Advanced Features* menu, to access *Diagnostics* menu see *Advanced Operation and Programming*, page 42.

This menu allows the user to test the functionality of all the meter LEDs, check the meter's software and version information, and erase the MeterView Pro software installation files from the meter. Press the Enter button to view the settings and the Menu button to exit at any time.

For a description of the diagnostic messages, see *Advanced Features Menu & Display Messages*, page 42.

### Determining Software Version

To determine the software version of a controller:

1. Go to the *Diagnostics* menu (d iRG) and press Enter button.
2. Press Up arrow button and scroll to Information menu (inFd).
3. Press Enter to access the software number (SFt) and version (UEr) information. Write down the information as it is displayed. Continue pressing Enter until all the information is displayed.
4. The controller returns to Run Mode after displaying all the settings.

## Reset Controller to Factory Defaults

When the parameters have been changed in a way that is difficult to determine what's happening, it might be better to start the setup process from the factory defaults.

**Instructions to load factory defaults:**

1. Enter the *Advanced Features* menu. See *Advanced Operation and Programming*, page 42.
2. Press Up arrow to go to *Diagnostics* menu
3. Press and hold Right arrow for three seconds, press Enter when display flashes rESEt.  
Note: If Enter is not pressed within three seconds, the display returns to the *Diagnostics* menu.
4. The controller goes through an initialization sequence (similar as on power-up), and loads the factory default settings.

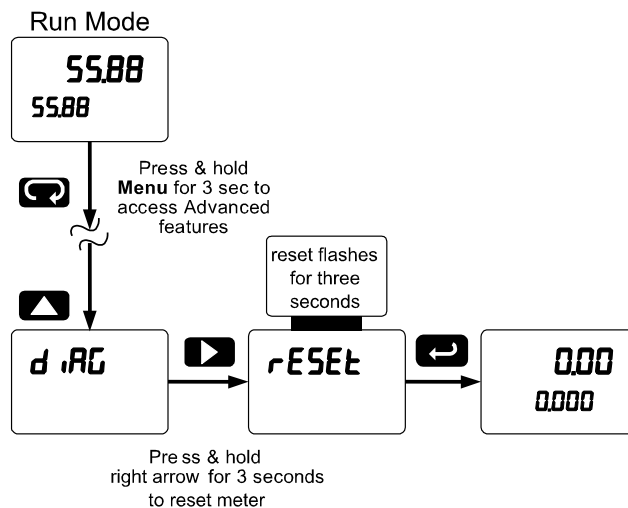

### Factory Defaults & User Settings

The following table shows the factory setting for the major programmable parameters on the controller.

Parameter	Display	Default Setting	Parameter	Display	Default Setting
Input type	<i>inPul</i>	Pulse	Relay 1 action	<i>Act 1</i>	Automatic
Total	<i>YES</i>	Total enabled	Batch preset	<i>PRESET</i>	100.0
Units (PD6310)	<i>units</i>	Rate / total / gr. total Pulse / Pulse / Pulse	Relay 2 action	<i>Act 2</i>	Automatic
Rate decimal point	<i>dddddd</i>	1 Place	Relay 2 set point	<i>SET 2</i>	200.0
Total decimal point	<i>dddddd</i>	1 Place	Relay 3 action	<i>Act 3</i>	Automatic
G. Total decimal point	<i>dddddd</i>	0 Places	Relay 3 set point	<i>SET 3</i>	3.000
K-factor	<i>Factor</i>	1.000	Relay 3 reset point	<i>rSE 3</i>	2.500
Function	<i>Function</i>	Linear	Relay 4 action	<i>Act 4</i>	Automatic
Number of points	<i>no Pts</i>	2	Relay 4 set point	<i>SET 4</i>	4.000
Programming	<i>Prog</i>	Scale	Relay 4 reset point	<i>rSE 4</i>	3.500
Input 1	<i>inP 1</i>	00000.0	Fail-safe relay 1	<i>FLS 1</i>	Off
Display 1	<i>d 15 1</i>	00000.0	Fail-safe relay 2	<i>FLS 2</i>	Off
Input 2	<i>inP 2</i>	10000.0	Fail-safe relay 3	<i>FLS 3</i>	Off
Display 2	<i>d 15 2</i>	10000.0	Fail-safe relay 4	<i>FLS 4</i>	Off
Display line 1	<i>Line 1</i>	Display total	On delay relay 1	<i>On 1</i>	0.0 sec
Display line 2	<i>Line 2</i>	Display rate and units	Off delay relay 1	<i>OFF 1</i>	0.0 sec
Display intensity	<i>d-int</i>	8	On delay relay 2	<i>On 2</i>	0.0 sec
Total time base	<i>t tb</i>	Second	Off delay relay 2	<i>OFF 2</i>	0.0 sec
Total conversion factor	<i>t CF</i>	1.000	On delay relay 3	<i>On 3</i>	0.0 sec
Batch mode	<i>mode</i>	Manual	Off delay relay 3	<i>OFF 3</i>	0.0 sec
Grand total time base	<i>gt tb</i>	Second	On delay relay 4	<i>On 4</i>	0.0 sec
Grand total conversion factor	<i>gt CF</i>	1.000	Off delay relay 4	<i>OFF 4</i>	0.0 sec
Grand total reset	<i>t rSE</i>	Manual	Display 1 analog out	<i>d 15 1</i>	0
Relay 1 assignment	<i>AS 1</i>	Total	Output 1 value	<i>Out 1</i>	4.000 mA
Relay 2 assignment	<i>AS 2</i>	Total			
Relay 2 preclose	<i>PRECLS</i>	No			
Relay 3 assignment	<i>AS 3</i>	Rate			
Relay 4 assignment	<i>AS 4</i>	Rate			

Parameter	Display	Default Setting
Display 2 analog out	d i 2	1000.0
Output 2 value	Out 2	20.000 mA
Source analog output	Source	Rate/process
Overrange output	OverRange	21.000 mA
Underrange output	UnderRange	3.000 mA
Loop break output	brERR	1.000 mA
Filter	Filter	Hi Spd
Cutoff value	Cutoff	0.000 (disabled)
Maximum output	max	23.000 mA
Minimum output	min	1.000 mA
Slave ID (Address)	SLAVE id	247
Baud rate	baud	9600
Transmit delay	tr dly	50 ms

Parameter	Display	Default Setting
Parity	PARITY	Even
Byte-to-byte timeout	t-byte	010 (0.1 sec)
F1 function key	F1	Start
F2 function key	F2	Preset
F3 function key	F3	Stop
F4 function	F4	Start/Stop
Digital input 1	d i 1	Menu
Digital input 2	d i 2	Right arrow
Digital input 3	d i 3	Up arrow
Digital input 4	d i 4	Enter
Digital output 1-4	DO 1	Alarm 1-4
Password 1	PRSS 1	000000 (unlocked)
Password 2	PRSS 2	000000 (unlocked)
Password 3	PRSS 3	000000 (unlocked)
Total password	total	000000 (unlocked)
Grand total password	Grand total	000000 (unlocked)

## Troubleshooting Tips

Symptom	Check/Action
No display at all	Check power at power connector
Not able to change setup or programming, <code>Locd</code> is displayed	Controller is password-protected, enter correct six-digit password to unlock
Controller displays error message during calibration ( <code>Error</code> )	Check: 1. Signal connections 2. Input selected in <i>Setup</i> menu 3. Minimum input span requirements
Controller displays 999999 -999999	Check: 1. Input selected in <i>Setup</i> menu 2. Corresponding signal at Signal connector
Display is unstable	Check: 1. Input signal stability and value 2. Display scaling vs. input signal 3. Filter and bypass values (increase)
Display response is too slow	Check filter and bypass values
Display reading is not accurate	1. Signal input conditioning selected: Linear, square root, etc. 2. Scaling or calibration
Display does not respond to input changes, reading a fixed number	Check: Display assignment, it might be displaying max, min, or set point.
Display alternates between 1. <code>H i</code> and a number 2. <code>Lo</code> and a number	Press Menu to exit max/min display readings.
Relay operation is reversed	Check: 1. Fail-safe in <i>Setup</i> menu 2. Wiring of relay contacts
Relay and status LED do not respond to signal	Check: 1. Relay action in <i>Setup</i> menu 2. Set and reset points
Flashing relay status LEDs	Relays in manual control mode or relay interlock switches opened.
Controller not communicating with application programs	Check: 1. Serial adapter and cable 2. Serial settings 3. Controller address and baud rate
If the display locks up or the controller does not respond at all	Cycle the power to reboot the microprocessor.
Other symptoms not described above	Call Technical Support for assistance.

*Note: Certain sequences of events can cause unexpected results. To solve these issues, it is best to start fresh from factory defaults and map changes ahead of time, rather than at random.*



## EU Declaration of Conformity

Issued in accordance with ISO/IEC 17050-1:2004.

We,

**Precision Digital Corporation**  
**233 South Street**  
**Hopkinton, MA 01748 USA**

as the manufacturer, declare under our sole responsibility that the product(s),

**Model PD6310 ProVu Series Pulse Batch Controller**

to which this declaration relates, is in conformity with the European Union Directives shown below:

<b>2014/35/EU</b>	<b>Low Voltage Directive</b>
<b>2014/30/EU</b>	<b>EMC Directive</b>
<b>2011/65/EU</b>	<b>RoHS Directive</b>

This conformity is based on compliance with the application of harmonized or applicable technical standards and, when applicable or required, a European Union notified body certification.

### Standards:

EN 55022:2003  
EN 61000-6-2:2001  
EN 61010-1:2001  
EN 61326:2006

The standards EN 55022:2003, EN 61000-6-2:2001, EN 61010-1:2001, and EN 61326:2006 are no longer harmonized. The requirements of these standards have been checked against the harmonized standards EN 55022:2010, EN 61000-6-2:2005, EN 61010-1:2010, and EN 61326:2013 and there were no major technical changes affecting the latest technical knowledge for the products listed above.

### Product Markings:



Signed for and on behalf of Precision Digital Corporation:

Name: Jeffrey Peters  
Company: Precision Digital Corporation  
Title: President  
Date: 04/20/2016

Document No: DoC PD6310 {042016}

## How to Contact Precision Digital

- For Technical Support, please  
Call: (800) 610-5239 or (508) 655-7300  
Fax: (508) 655-8990  
Email: [support@predig.com](mailto:support@predig.com)
- For Sales Support or to place an order, please contact your local distributor or  
Call: (800) 343-1001 or (508) 655-7300  
Fax: (508) 655-8990  
Email: [sales@predig.com](mailto:sales@predig.com)
- For the latest version of this manual, please visit  
[www.predig.com](http://www.predig.com)

### PRECISION DIGITAL CORPORATION

233 South Street • Hopkinton MA 01748 USA  
Tel (800) 343-1001 • Fax (508) 655-8990



[www.predig.com](http://www.predig.com)