

PD154 & PD158 VIGILANTE® II ANNUNCIATORS Instruction Manual

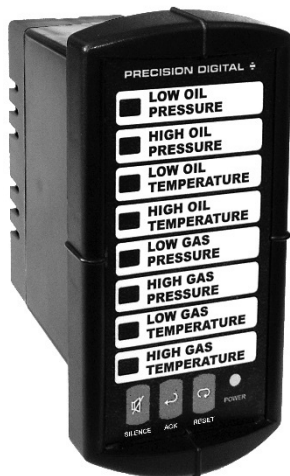

- 8 Field Selectable Sequences
- All Common ISA Sequences
- 4 or 8-Point (Channel) Monitoring
- Free Replaceable Message Labels
- Type 4X, NEMA 4X, IP65 Front
- Universal Power Supply 85-265 VAC
- 12-36 VDC/12-24 VAC Power Option
- Built-In 85 dB Horn
- 2 SPDT Relays
- 24 VDC Isolated Power Supply (AC Models)
- Multiple-Unit First-Out Indication
- 3 Pushbutton Operation
- Sunlight Readable Indication

Vigilante II

Monitor
up to 8
Inputs!

PRECISION DIGITAL CORPORATION
233 South Street • Hopkinton MA 01748 USA
Tel (800) 343-1001 • Fax (508) 655-8990

**PRECISION
DIGITAL**

www.predig.com

INTRODUCTION

The Vigilante® II is a multipurpose panel mounted alarm annunciator. It has 8 field selectable alarm sequences, including all common ISA sequences. The alarm channels accept normally open, normally closed, NPN open collector transistor, and logic level inputs. Three front panel pushbuttons are used during sequence operation to silence the horn, acknowledge the first out alarm, and reset cleared channels as required by the sequences.

The Vigilante II has two SPDT relays that can be used for additional external alarm indication, additional audible devices, or for process control. The isolated 24 VDC power supply available on 85-265 VAC models can be used to power additional devices and external indicators.

Disclaimer

The information contained in this document is subject to change without notice. Precision Digital makes no representations or warranties with respect to the contents hereof, and specifically disclaims any implied warranties of merchantability or fitness for a particular purpose.

Registered Trademarks

Vigilante® II is a registered trademark of Precision Digital Corporation. All other trademarks mentioned in this document are the property of their respective owners.

© 2010-2016 Precision Digital Corporation. All rights reserved.

ORDERING INFORMATION

85-265 VAC* Model	12-36 VDC* Model	Description
PD154-6R2-1	PD154-7R2-0	Vigilante® II 4-Point Annunciator
PD158-6R2-1	PD158-7R2-0	Vigilante® II 8-Point Annunciator
*All models may be powered from AC or DC, see Specifications for details.		

Enclosures and Accessories

Model	# of Units	Description	Mounting
PDA2500-V	1 - 6	Plastic NEMA 4X Enclosure	Through Door
PDA2522	2	Plastic NEMA 4X Enclosure; 1(V) 1(H)	Through Door
PDA2600-V	1 - 6	Stainless Steel NEMA 4X Enclosure	Through Door
PDA2622	2	SS NEMA 4X Enclosure; 1(V) 1(H)	Through Door
PDA2700-V	1 - 6	Steel NEMA 4 Enclosure	Through Door
PDA2722	2	Steel NEMA 4 Enclosure; 1(V) 1(H)	Through Door
PDA2801	1	Plastic NEMA 4X Enclosure	Through Cover
PDX6901		Snubber 0.01µF, 470Ω, Flexible Leads	

QUICK SETUP GUIDE

The following overview details how to set up the annunciator for most common uses.

Sequence Selection

The two most common sequences are ISA A and ISA F2A. Select the sequence using the four-position switch on the rear of the unit above the signal connector. For complete sequence details, see page 30.

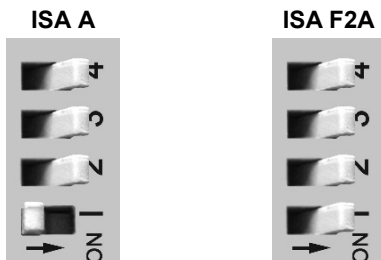

NO/NC Inputs

Each input can be set for normally open (NO) or normally closed (NC) contacts. Each input channel is programmed individually. The default setting is for all inputs to be NO.

To set inputs to NC:

1. Press and hold **ACK** and **RESET** for 3 seconds until all LEDs cycle.
2. Press **ACK** within 3 seconds of release. All LEDs will blink. If **ACK** is not pressed within 3 seconds, the unit will return to run mode.
3. Press **ACK** again within 3 seconds of release. If **ACK** is not pressed within 3 seconds, the unit will return to run mode.

The LED for the channel being programmed will display brightly on or off. All other channel indication LEDs will be at low intensity to indicate programming mode.

4. Press the **RESET** pushbutton to turn LED 1 off for a NO input, or on for a NC input for channel 1.
5. Press **ACK** to accept the input type and program channel 2.
6. Repeat steps 4 and 5 for all input channels.
7. Press and hold **ACK** for five seconds to return to normal operation with the programmed input types.

Basic Connections

All connections are made to removable screw terminal connectors located at the rear of the instrument. For complete connection details, see page 12.



Use copper wire with 60°C or 60/75°C insulation for all line voltage connections. Observe all safety regulations. Electrical wiring should be performed in accordance with all applicable national, state, and local codes to prevent damage to the instrument and ensure personnel safety.

Connector Labeling

The connectors label, affixed to the instrument, shows the location of all connectors available with requested configuration. See Figure 2, page 12.

Power Connections

Power connections are made to a two-terminal connector labeled POWER. The instrument will operate regardless of DC polarity connection. The + and - symbols are only a suggested wiring convention.

Signal Connections

Input signal connections are made to a 14-terminal connector at terminals labeled INPUT CHANNELS. The COM (common) terminal is the return for all input channels.

Normally Open (NO) or Normally Closed (NC) Switches

All channels are initially set for normally open contacts. Each contact is wired across an input channel and common.

Relays and 24 V Output Connections

Relay connections are made to a six-terminal connector labeled RELAY1, RELAY2. The COM (common) terminals of the relays should not be confused with the COM (common) terminal of the signal connector. The 24 VDC output is available at the connector labeled 24V OUT, next to the relays connector.

Additional Information

For additional setup and wiring information, please see the complete details further in this manual.

Table of Contents

INTRODUCTION	2
ORDERING INFORMATION	2
QUICK SETUP GUIDE	3
Sequence Selection	3
NO/NC Inputs	3
Basic Connections	4
SPECIFICATIONS	7
General	7
Inputs	8
Relays	8
COMPLIANCE INFORMATION	9
SAFETY INFORMATION	10
INSTALLATION	11
Unpacking	11
Panel Mounting	11
Connections	12
Connector Labeling	12
Power Connections	12
Signal Connections	13
Relays and 24 V Output Connections	14
Switching Inductive Loads	15
External Pushbutton Connections	16
Multiple Unit First-Out Indication Connections	16
SETUP AND PROGRAMMING	17
Front Panel Pushbuttons and Status LED Indicators	18
Full Function Test	19
Multiple Unit First-Out Indication	19
Shared Front Panel Buttons	19
Annunciator Sequence Selection	20
Sequence Programming	20
Sequence Descriptions	20
Normally Open/Normally Closed Input Setup	21
Programming NO/NC Inputs	21
NO/NC Programming Example	22
Relay Operation	23
Relay 1 Operation	23
Relay 2 Operation	23
Relay Fail-Safe	23

Programming Relay Fail-Safe	23
Relay Fail-Safe Programming Example	24
Relay Operation Overview	25
Audible Horn Enable/Disable	26
Enabling/Disabling Silence Option	26
No Lock-In Sequence Option	27
Reset to Factory Defaults	27
MOUNTING DIMENSIONS	28
TROUBLESHOOTING	29
FULL SEQUENCE DESCRIPTIONS	30
Features	30
Sequence Condition Descriptions	30
LED Condition Descriptions	30
ISA Sequence A	31
Relay Operation	31
ISA Sequence F2A	32
ISA Sequence F1A	33
ISA Sequence F3A	34
Sequence F3A Switch Positions	34
Input Follower Indication	36
ISA Sequence M	36
ISA Sequence F1M	37
ISA Sequence F2M	38
EU DECLARATION OF CONFORMITY	39

Table of Figures

Figure 1. Panel Cutout and Mounting	11
Figure 2. Connector Labeling for PD158-6R2-1	12
Figure 3. Power Connections	12
Figure 4. NO/NC Contact Inputs	13
Figure 5. Open Collector NPN Transistor Inputs	14
Figure 6. Relay & 24 V Output Connections	14
Figure 7. AC and DC Loads Protection	15
Figure 8. Low Voltage DC Loads Protection	15
Figure 9. External Pushbutton Connections	16
Figure 10. System with Multiple Units Share First-Out	17
Figure 11. Shared Pushbutton Connections	19
Figure 12. DIP Switch Location	20
Figure 13. Case Dimensions – Side View	28
Figure 14. Case Dimensions – Top View	28

SPECIFICATIONS

Except where noted all specifications apply to operation at +25°C.

General

DISPLAY	PD154; Four red LED channel/point indicators. PD158; Eight red LED channel/point indicators. One green LED power indicator.
ALARM MESSAGES	Custom printed adhesive clear labels. Area: PD154, 1.25" x .60" (32 mm x 15 mm), 4 messages PD158, 1.25" x .25" (32 mm x 6 mm), 8 messages User specified size and length, up to 4 lines (PD154) or 2 lines (PD158) of 14 characters of size 9 fonts.
PROGRAMMING METHODS	Rear 4-position switch for sequence selection and horn operation. Three front panel pushbuttons for NO/NC input selection, sequence options, and sequence operation.
NOISE FILTER	40 ms debounce on inputs (including SIL, ACK, and RST).
SHARED FIRST-OUT SYSTEMS	1 ms unit-to-unit delay. Maximum of 200 units in the shared first-out system.
NON-VOLATILE MEMORY	All programmed settings are stored in non-volatile memory for a minimum of ten years if power is lost.
POWER OPTIONS	85-265 VAC, 50/60 Hz 90-265 VDC, 20 W max or 12-36 VDC, 12-24 VAC, 6 W max
FUSE	Required external fuse: UL Recognized, 5 A max, slow blow. Up to 6 annunciators may share one 5 A fuse
ISOLATED POWER SUPPLY	24 VDC \pm 10% @ 200 mA max Standard on 85-265 VAC powered units only.
ISOLATION	4 kV input/output-to-power line.
OVERVOLTAGE CATEGORY	Installation Overvoltage Category II: Local level with smaller transient overvoltages than Installation Overvoltage Category III
ENVIRONMENTAL	Operating temperature range: -40 to 65°C Storage temperature range: -40 to 85°C Relative humidity: 0 to 90% non-condensing
CONNECTIONS	Removable screw terminal blocks for 12 to 22 AWG wire.
ENCLOSURE	1/8 DIN, high impact plastic, UL 94V-0, front color: black
MOUNTING	1/8 DIN panel cutout required. Two panel mounting bracket assemblies provided.
TIGHTENING TORQUE	Screw terminal connectors: 5 lb-in (0.56 Nm)
OVERALL DIMENSIONS	4.68" x 2.45" x 4.19" (62 mm x 119 mm x 106 mm) (H x W x D)

WEIGHT	9.6 oz (272 g)
WARRANTY	3 years parts & labor
EXTENDED WARRANTY	1 or 2 years, refer to the Price List for details.

Inputs

INPUT TYPES	NO or NC switches: No external excitation required Open collector transistor (NPN): Open circuit voltage approximately 3.3 VDC Logic Levels: LOW = 0 to 0.9 VDC HIGH = 2.4 to 28 VDC
UPDATE RATE	41 ms following alarm state; 1 ms for alarm state clear
SEQUENCES	Input follower, ISA Sequences A, F1A, F2A, F3A, M, F1M, F2M and F3M per ISA Standard ISA-18.1-1979 R2004.
SEQUENCE OPTIONS	A, F1A, F2A, F3A, M, F1M, F2M, and input follower with selectable options -1 (silence pushbutton), -4 (no lock-in), and -6 (no horn) per ISA Standard ISA-18.1-1979 R2004.

Relays

RATING	2 SPDT (Form C); rated 3 A @ 30 VDC or 3 A @ 250 VAC resistive load; 1/14 HP @ 125/250 VAC for inductive loads
ELECTRICAL NOISE SUPPRESSION	A suppressor (snubber) should be connected to each relay contact switching inductive loads to prevent disruption to the microprocessor's operation. Recommended suppressor value: 0.01 μ F/470 Ω , 250 VAC (PDX6901).
RELAY OPERATION	Relay 1: Alarm state until alarm is acknowledged. Relay 2: Alarm state while any channel indicating alarm condition.
FAIL-SAFE OPERATION	Programmable Independent for each relay Note: In fail-safe mode, relay coil is energized in non-alarm condition. In case of power failure, relay will go to alarm state.

COMPLIANCE INFORMATION**Safety**

UL LISTED	USA and Canada UL 508 Industrial Control Equipment
UL FILE NUMBER	E160849
FRONT PANEL	UL Type 4X, NEMA 4X, IP65; panel gasket provided
LOW VOLTAGE DIRECTIVE	EN 61010-1:2010 Safety requirements for measurement, control, and laboratory use

Electromagnetic Compatibility

EMISSIONS	EN 55022:2010 Class A ITE emissions requirements
Radiated Emissions	Class A
AC Mains Conducted Emissions	Class A
IMMUNITY	EN 61326-1:2013 Measurement, control, and laboratory equipment EN 61000-6-2:2005 EMC heavy industrial generic immunity standard
RFI - Amplitude Modulated	80 -1000 MHz 10 V/m 80% AM (1 kHz) 1.4 - 2.0 GHz 3 V/m 80% AM (1 kHz) 2.0 - 2.7 GHz 1 V/m 80% AM (1 kHz)
Electrical Fast Transients	±2kV AC mains, ±1kV other
Electrostatic Discharge	±4kV contact, ±8kV air
RFI - Conducted	10V, 0.15-80 MHz, 1kHz 80% AM
AC Surge	±2kV Common, ±1kV Differential
Surge	1KV (CM)
Power-Frequency Magnetic Field	30 A/m 70%V for 0.5 period
Voltage Dips	40%V for 5 & 50 periods 70%V for 25 periods
Voltage Interruptions	<5%V for 250 periods

SAFETY INFORMATION

CAUTION: Read complete instructions prior to installation and operation of the instrument.



WARNING: Risk of electric shock.

**WARNING**

Hazardous voltages exist within enclosure. Installation and service should be performed only by trained service personnel.

INSTALLATION

There is no need to remove the instrument from its case to complete the installation, wiring, and setup.

Unpacking

Remove the instrument from box. Inspect the packaging and contents for damage. Report damages, if any, to the carrier.

If any part is missing or the unit malfunctions, please contact your supplier or the factory for assistance.

Panel Mounting

- Prepare a standard 1/8 DIN vertical panel cutout – 1.772" x 3.622" (45 mm x 92 mm). Refer to Figure 1 for more details.
- Clearance: allow at least 4" (102 mm) behind the panel for wiring.
- Panel thickness: 0.04" - 0.25" (1.0 mm - 6.4 mm). Recommended minimum panel thickness to maintain Type 4X rating: 0.06" (1.5 mm) steel panel, 0.16" (4.1 mm) plastic panel.
- Remove the two mounting brackets provided with the meter (back-off the two screws so that there is 1/4" (6.4 mm) or less through the bracket. Slide the bracket toward the front of the case and remove).
- Insert the unit into the panel cutout.
- Install mounting brackets and tighten the screws against the panel. To achieve a proper seal, tighten the mounting bracket screws evenly until the front is snug to the panel along its short side. **DO NOT OVER TIGHTEN**, as the rear of the panel may be damaged.

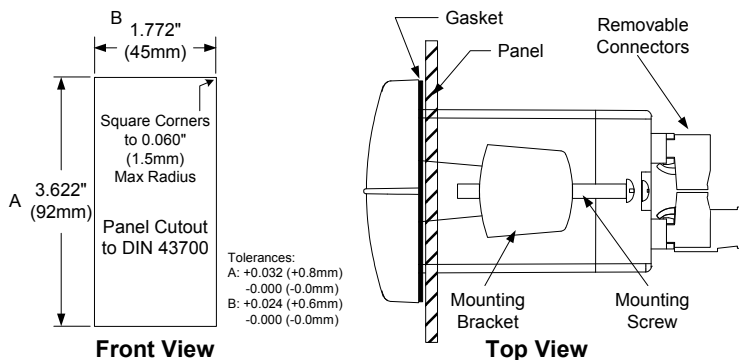

Figure 1. Panel Cutout and Mounting

Connections

All connections are made to removable screw terminal connectors located at the rear of the instrument.



Use copper wire with 60°C or 60/75°C insulation for all line voltage connections. Observe all safety regulations. Electrical wiring should be performed in accordance with all applicable national, state, and local codes to prevent damage to the instrument and ensure personnel safety.

Connector Labeling

The connectors label, affixed to the instrument, shows the location of all connectors available with requested configuration.

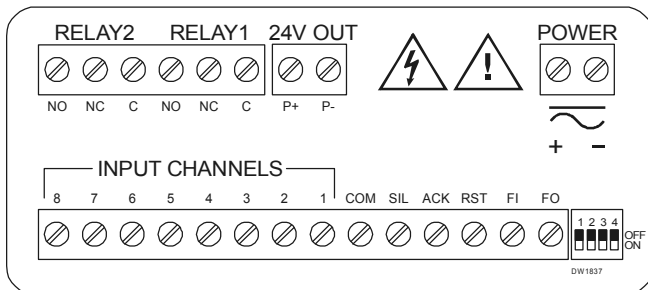

Figure 2. Connector Labeling for PD158-6R2-1

Power Connections

Power connections are made to a two-terminal connector labeled POWER on Figure 2. The instrument will operate regardless of DC polarity connection. The + and - symbols are only a suggested wiring convention.

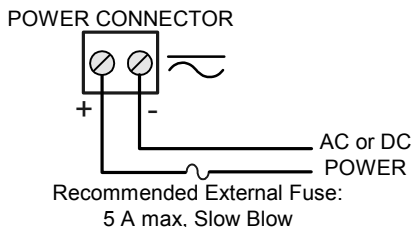

Figure 3. Power Connections

Signal Connections

Input signal connections are made to a 14-terminal connector at terminals labeled INPUT CHANNELS on Figure 2. The COM (common) terminal is the return for all types of input signals.

Normally Open (NO) or Normally Closed (NC) Switches

The following figure shows an example of normally open or normally closed contact inputs.

Programming a channel for a normally open or normally closed contact is done with the front panel pushbuttons (see page 21). All channels are initially set for normally open contacts. Each contact is wired across an input channel and common.

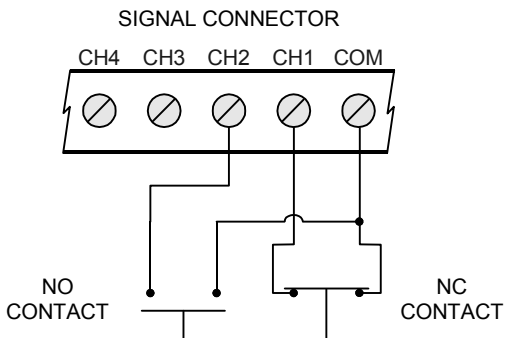

Figure 4. NO/NC Contact Inputs

Open Collector NPN Transistor

Each transistor collector is connected to a separate input channel and all emitters connected to common. All channels are factory set for transistor inputs normally in the cutoff or "off" state. For normally active/saturation state or "on" transistors, program inputs for normally closed input operation; see page 21.

Open circuit voltage is approximately 3.3 VDC provided by a 47 k Ω internal pullup resistor.

The following figure shows an example of open collector NPN transistor inputs.

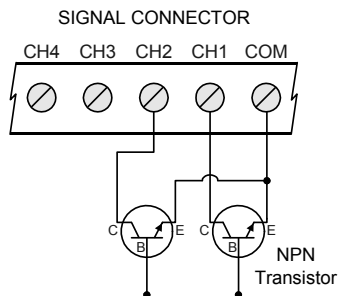

Figure 5. Open Collector NPN Transistor Inputs

Logic Level Inputs

Each logic level input is connected to an input channel with common as the return.

Logic level inputs are factory set for normally high active logic level inputs. For normally low input logic levels, program inputs for normally closed input operation, see page 21.

Logic Level Low: 0 to 1.4 VDC

Logic Level High: 1.5 to 28 VDC

Input Impedance: Approximately 47 k Ω

Relays and 24 V Output Connections

Relay connections are made to a six-terminal connector labeled RELAY1, RELAY2 on Figure 2. The COM (common) terminals of the relays should not be confused with the COM (common) terminal of the signal connector. The 24 VDC output is available at the connector labeled 24V OUT, next to the relays connector.

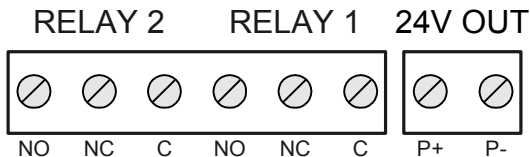

Figure 6. Relay & 24 V Output Connections

Switching Inductive Loads

The use of suppressors (snubbers) is strongly recommended when switching inductive loads to prevent disrupting the microprocessor's operation. The suppressors also prolong the life of the relay contacts. Suppression can be obtained with resistor-capacitor (RC) networks assembled by the user or purchased as complete assemblies. Refer to the following circuits for RC network assembly and installation:

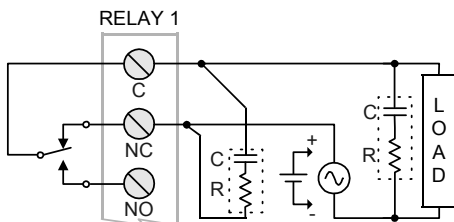

Figure 7. AC and DC Loads Protection

Choose R and C as follows:

R: 0.5 to 1 Ω for each volt across the contacts

C: 0.5 to 1 μF for each amp through closed contacts

Notes:

1. Use capacitors rated for 250 VAC.
2. RC networks may affect load release time of solenoid loads. Check to confirm proper operation.
3. Install the RC network at the meter's relay screw terminals. An RC network may also be installed across the load. Experiment for best results.

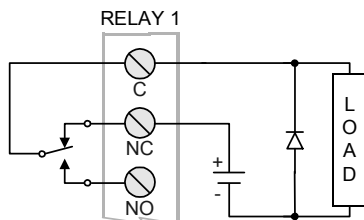

Use a diode with a reverse breakdown voltage two to three times the circuit voltage and forward current at least as large as the load current.

Figure 8. Low Voltage DC Loads Protection

RC Networks Available from Precision Digital

RC networks are available from Precision Digital and should be applied to each relay contact switching an inductive load. Part number: PDX6901.

External Input Types

The external Silence (SIL), Acknowledge (ACK), and Reset (RST) inputs may be: contacts (i.e. pushbuttons, relay contacts, etc.), open collector inputs (OC), or TTL signals. However, throughout this manual, the term “pushbutton” is used to describe these external inputs. Please refer to the chart below for signal logic.

External Input Type	Active When
Switch/Contact	Closed
Open Collector (OC)	On
TTL	Low

External Pushbutton Connections

The front panel pushbuttons may also be triggered with pushbuttons connected to the signal connector terminals shown in Figure 2. Switch SIL to common for the silence pushbutton, ACK to common for the acknowledge pushbutton, and RST to common for the reset pushbutton. The following figure shows external pushbutton wiring connections. Do not wire-short the external pushbutton contacts to common.

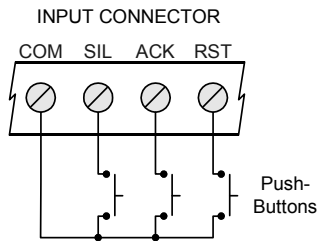

Figure 9. External Pushbutton Connections

Multiple Unit First-Out Indication Connections

Multiple PD158 and PD154 units can keep a single first-out channel indicated for all connected units. An unlimited number of units may be connected. It is recommended that all units follow the same sequence. The following figure shows shared first-out indication wiring connections for 3 units. Up to 200 units may be connected for first-out indication.

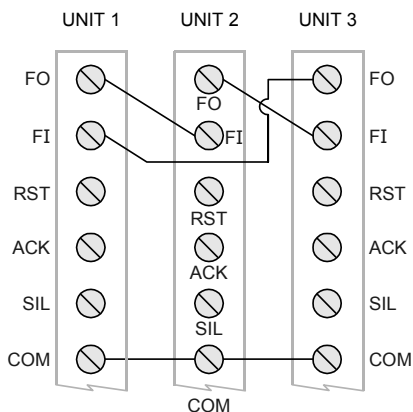

Figure 10. System with Multiple Units Share First-Out

SETUP AND PROGRAMMING

Overview



There are no jumpers involved in the setup process of the annunciator. The sequence selector switch, located on the rear of the annunciator above the signal connector must be set accordingly for annunciator sequence desired.

Normally open or normally closed input setup, relay fail-safe, and additional sequence options are programmed with the front panel pushbuttons.

After power and signal connections have been completed and verified, and the sequence selector switch has been set appropriately, apply power to the annunciator.

For a **Quick Setup Guide**
go to page 3

Front Panel Pushbuttons and Status LED Indicators

Button	Description
	Silence Horn
	Acknowledge Alarm
	Reset Clear Input Channels
LED	Description
Red Indicators ¹	Channel status indicators
Green Indicator	Indicates power is on.

1. Quantity 4 red LED on the PD154
Quantity 8 red LED on the PD158

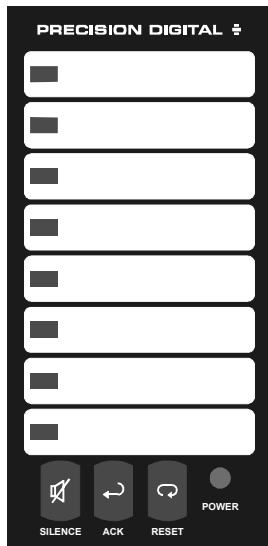

Pushbutton Descriptions

SILENCE

Silences the audible alarm without affecting the indication sequence states. This pushbutton may be disabled (see page 26).

ACK (Acknowledge)

Acknowledges alarmed channels. See selected sequence details for complete function description (see page 30).

RESET

Resets all acknowledged channels. This button is not used on ISA sequences A, F1A, and F2A, which reset acknowledged channels automatically. See selected sequence details for complete function description (see page 30).

LED TEST (SILENCE & ACK)

Press and release the **SILENCE** and **ACK** pushbuttons to flash the channel indicator LEDs for a lamp test.

Full Function Test

Press and hold **SILENCE** and **ACK** for 5 seconds to perform a function test. This tests the sequence operation and hardware by simulating alarm inputs that are cleared in the normal sequence progression.

During the function test, all channels enter a simulated alarm state for 3 seconds. All LEDs, pushbuttons, relays, and the audible alarm will follow the selected sequence as if the simulated alarm inputs were real. After 3 seconds, the alarms may be cleared as normal for the selected sequence.

Multiple Unit First-Out Indication

If multiple Vigilante II annunciators are connected for multiple unit shared first-out indication (see page 16), only one input from all connected devices will display as a first-out alarm.

Each individual annunciator will acknowledge and reset the channels on that unit using the pushbuttons on that unit, and independent of all other connected units. Only the unit displaying the first-out will sound the audible alarm.

It is recommended that all connected units be set for the same first-out sequence.

Shared Front Panel Buttons

To control all the units from any of the front panels, connect the SIL, ACK, RST, and COM terminals on each unit.

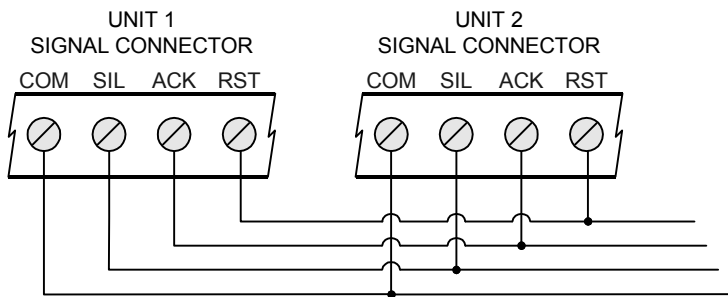

Figure 11. Shared Pushbutton Connections

Annunciator Sequence Selection

The alarm sequence is selected with the DIP switch located above the signal connector.

Changing sequences while the unit is on will restart the unit.

Sequence Programming

Set switches to the positions shown below for the desired sequence. The annunciator will immediately restart and operate with the new sequence.

Sequence Selector Switch

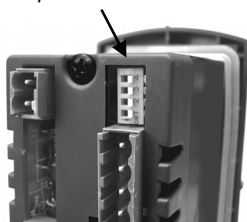
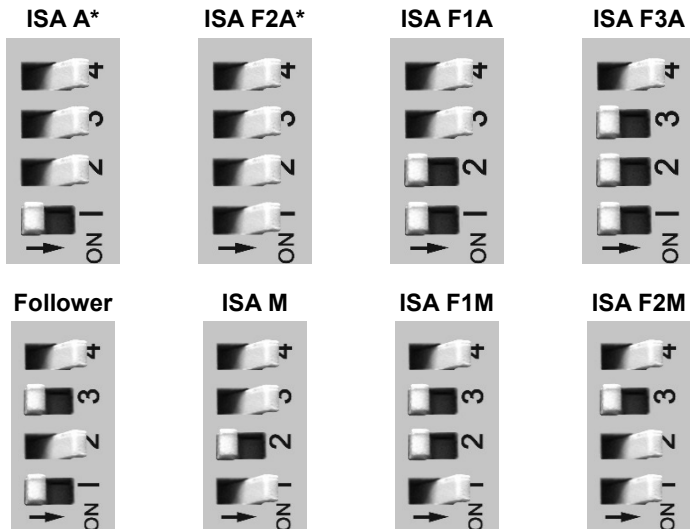

Figure 12. DIP Switch Location



*Common sequences available on other Precision Digital Annunciators

Sequence Descriptions

See Page 30 for complete sequence descriptions.

Normally Open/Normally Closed Input Setup

Each input channel is independently programmed for a normally open or normally closed input. All channels are initially programmed at the factory for normally open inputs.

Alarm Conditions for normally open inputs:

1. A closed contact between an input channel and common will cause an alarm condition.
2. An “on” or active transistor between an input channel and common will cause an alarm condition.
3. An active logic level low on an input channel will cause an alarm condition.

Alarm Conditions for normally closed inputs:

1. An open contact between an input channel and common will cause an alarm condition.
2. An “off” or cutoff state transistor between an input channel and common will cause an alarm condition.
3. An active logic level high or no supplied active logic level on an input channel will cause an alarm condition.

Programming NO/NC Inputs

1. Press and hold **ACK** and **RESET** for 3 seconds until all LEDs cycle, then release
2. Press **ACK** within 3 seconds of release while LEDs cycle.¹
3. Press **ACK** within 3 seconds of release while LEDs blink.¹
4. Press the **RESET** pushbutton to turn LED 1 off for a NO input, or on for a NC input on input channel 1.
5. Press **ACK** to accept the input type and program channel 2.
6. Repeat steps 4 and 5 for all input channels.
7. Press and hold **ACK** for five seconds to return to normal operation with the programmed input types.

During programming, the LED for the channel being programmed will display as either off or brightly on. All other LEDs will be dim.

The green power LED will blink slowly to indicate the unit is in NO/NC setup mode. The unit will automatically leave setup mode if no pushbutton is pressed for 3 minutes.

¹The unit will automatically leave setup mode if steps 2 and 3 are not followed.

NO/NC Programming Example

The following is an example of NO/NC setup. Input channel 1 and 2 are changed from the default settings of NO to be NC inputs.

1. Press and hold **ACK** and **RESET** for 3 seconds. When all LEDs cycle, release.
2. Press **ACK** within 3 seconds. All LEDs blink in unison.
3. Press **ACK** again while LEDs blink

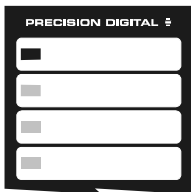

4. LED 1 will be off indicating a NO input for channel 1. All other LEDs will be dim.

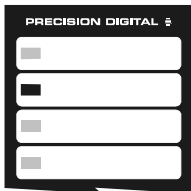

6. Press **ACK** to confirm the NC setting and proceed to program channel 2.

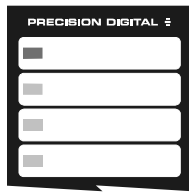

5. Press **RESET** to change LED 1 from off to on, setting channel 1 for a NC input.

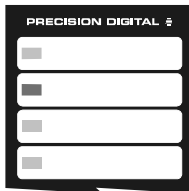

7. Press **RESET** to change LED 2 from off to on, setting channel 2 for a NC input.

8. Press **ACK** to confirm the NC setting and program channel 3.
9. Press and hold **ACK** for five seconds to return to normal operation.

Relay Operation

Relays 1 and 2 have standard functionality as defined below.

Relay 1 Operation

Relay 1 enters alarm state when there is a new alarm. This relay will clear when the alarm is acknowledged, generally by pressing the **ACK** pushbutton.

Relay 2 Operation

Relay 2 enters alarm state when any channel displays in alarm state. This relay will clear when all indication LEDs are cleared.

Relay Fail-Safe

In fail-safe operation, a relay coil is energized in non-alarm condition. In case of power failure, relays will go to alarm state. Fail-safe operation is set independently for each relay.

Programming Relay Fail-Safe

1. Press and hold **ACK** and **RESET** for 3 seconds. When all LEDs cycle, release.
2. Press **RESET** within 3 seconds of release while LEDs cycle.¹
3. Press **RESET** within 3 seconds of release while LEDs blink.¹
4. Press the **RESET** pushbutton to turn LED 1 off for normal operation, or on for fail-safe operation of Relay 1.
5. Press **ACK** to accept the type of operation for Relay 1.
6. Press the **RESET** pushbutton to turn LED 2 off for normal operation, or on for fail-safe operation of Relay 2.
7. Press **ACK** to accept the type of operation for Relay 2.
8. Press and hold **ACK** for five seconds to return to operation.

During programming, LEDs 1 through 4 will light. The LED being programmed will display as either off or brightly on. The other 3 LEDs will be dim. On a PD158, LEDs 5 through 8 will be off.

The green power LED will blink quickly to indicate the unit is in the advanced programming mode. The unit will automatically leave setup mode if no pushbutton is pressed for 3 minutes.

Note: LED 3 and 4 are used for the *silence pushbutton enable/disable option (see page 26)* and *no lock-in option (see page 26)*

¹The unit will automatically leave setup mode if steps 2 and 3 are not followed.

Relay Fail-Safe Programming Example

The following is an example of relay fail-safe setup. Relays 1 and 2 are changed from the default settings of normal operation to fail-safe operation.

1. Press and hold **ACK** and **RESET** for 3 seconds. When all LEDs cycle, release.
2. Press **RESET** within 3 seconds of release while LEDs cycle. All LEDs blink in unison.
3. Press **RESET** again within 3 seconds while LEDs blink

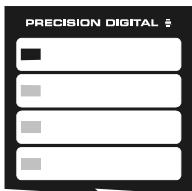

4. LED 1 will be off indicating normal operation of relay 1. LEDs 2 through 4 will be dim.

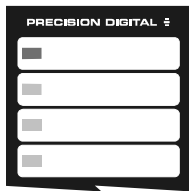

5. Press Reset to change LED 1 from off to on, setting relay 1 for fail-safe operation.

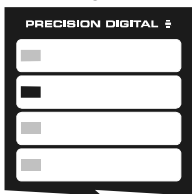

6. Press **ACK** to confirm the setting for relay 1 and proceed to program relay 2.

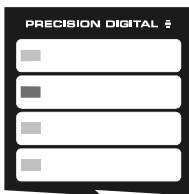

7. Press **RESET** to change LED 2 from off to on, setting relay 2 for fail-safe operation.

8. Press **ACK** to confirm the setting for relay 2.
9. Press and hold **ACK** for 5 seconds to return to normal operation.

Note: LEDs 3 and 4 are used for the silence pushbutton enable/disable option (see page 26) and no lock-in option (see page 26)

Relay Operation Overview

The following figure illustrates the operation of the relays.

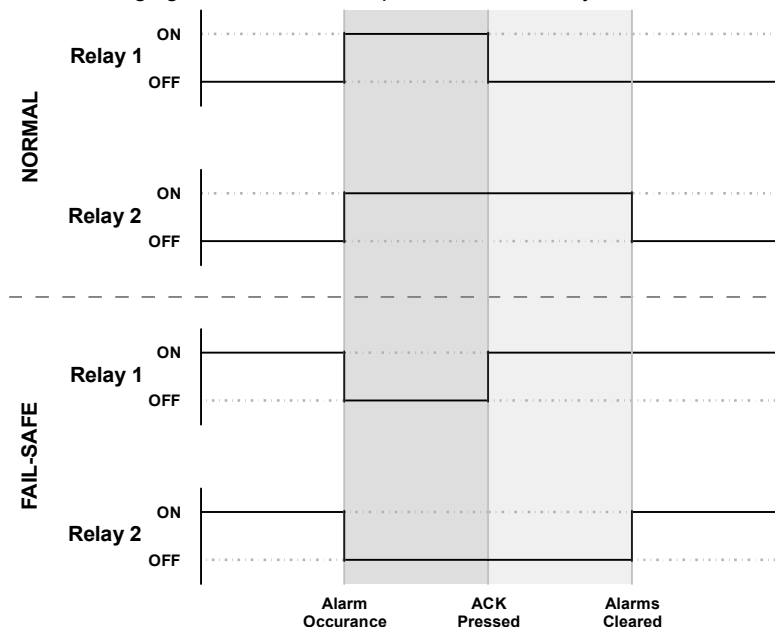

Relay On: Relay is energized

Relay Off: Relay is de-energized.

Alarm Occurrence: A new alarm occurs when there is no previous unacknowledged alarm.

ACK Pressed: The Acknowledge pushbutton is pressed, acknowledging the alarm.

Alarms Cleared: All LED indicators are cleared of alarm state indication

Audible Horn Enable/Disable

The annunciator contains an audible internal horn. This horn may be disabled with the rear-mounted switch located above the signal connector. To enable the horn, move switch 4 to the ON position. To disable the horn, move switch 4 to the OFF position.



Sequence F2A
Horn Enabled



Sequence F2A
Horn Disabled

Enabling/Disabling Silence Option

ISA sequence option 1, *Silence Pushbutton*, includes a silence pushbutton. This option may be disabled, removing any effects of the silence pushbutton or silence pushbutton external contact. This option is enabled by factory default.

Silence Pushbutton Enable/Disable

1. Press and hold **ACK** and **RESET** for 3 seconds until all LEDs cycle, then release.
2. Press **RESET** within 3 seconds of release while LEDs cycle.¹
3. Press **RESET** within 3 seconds of release while LEDs blink.¹
4. Press the **ACK** pushbutton twice until LED 3 is either off or brightly on.
5. Press the **RESET** pushbutton to turn LED 3 off to disable the silence pushbutton or brightly on to enable the silence pushbutton.
6. Press **ACK** to accept the silence pushbutton setting.
7. Press and hold **ACK** for five seconds to return to normal operation.

The green power LED will blink quickly to indicate the unit is in the advanced programming mode. The unit will automatically leave setup mode if no pushbutton is pressed for 3 minutes.

Note: LED 1 and 2 are used for relay fail-safe setup (see page 23)

¹The unit will automatically leave setup mode if steps 2 and 3 are not followed.

No Lock-In Sequence Option

ISA sequence option 4 *no lock-in*, may be added to any sequence. Momentary alarms will clear without the **ACK** pushbutton. Sequences A, F1A, F2A, and F3A will automatically clear any momentary alarm. Sequences M, F1M, and F2M will clear all momentary alarms when the **RESET** pushbutton is used, regardless of what channels have previously been acknowledged with **ACK**.

Selecting No Lock-In Operation

1. Press and hold **ACK** and **RESET** for 3 seconds until all LEDs cycle, then release.
2. Press **RESET** within 3 seconds of release while LEDs cycle.¹
3. Press **RESET** within 3 seconds while LEDs blink.¹
4. Press the **ACK** pushbutton three times until LED 4 is either off or brightly on.
5. Press the **RESET** pushbutton to turn LED 4 off to disable the no lock-in option or on to enable the no lock-in option.
6. Press **ACK** to accept the option setting.
7. Press and hold **ACK** for five seconds to return to operation.

The green power LED will blink quickly to indicate the unit is in the advanced programming mode. The unit will automatically leave setup mode if no pushbutton is pressed for 3 minutes.

Note: LED 1 and 2 are used for relay fail-safe setup (see page 23), and LED 3 is used for silence pushbutton enable/disable (see page 26).

¹The unit will automatically leave setup mode if steps 2 and 3 are not followed.

Reset to Factory Defaults

1. Hold the **ACK** and **RESET** pushbuttons for 3 seconds until all red LEDs cycle. Release once the LEDs begin to cycle.
2. Press and hold the **RESET** button for 5 seconds. If the **RESET** button is not pressed within 3 seconds of releasing **ACK** and **RESET**, the unit will return to run mode without reset.
3. Reset the 4-position switch on the rear of the control to the indicated default settings.

**Factory Default
Switch Positions**



MOUNTING DIMENSIONS

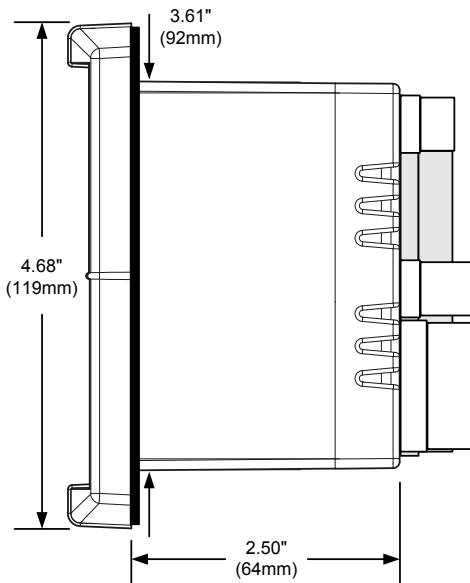

Figure 13. Case Dimensions – Side View

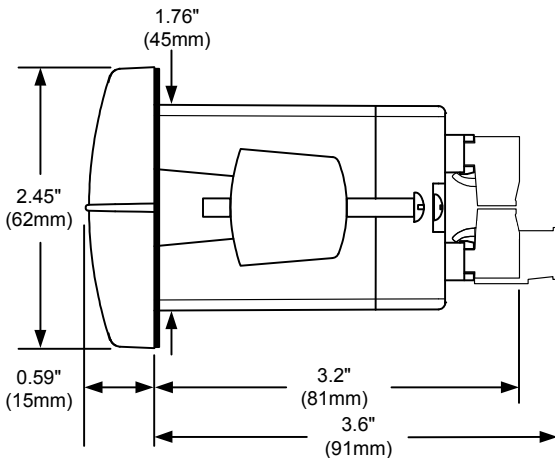

Figure 14. Case Dimensions – Top View

TROUBLESHOOTING

If the annunciator is not working as expected, refer to the recommendations below.

Troubleshooting Tips

Symptom	Check/Action
Power LED off	Check power at power connector
Audible alarm does not sound when alarm state detected	Check: 1. Rear switch position 4 is ON. 2. No external pushbutton contacts on the input connector are shorted.
Power light blinks and channel/point indicators flash intermittently when powered up.	Check that no external pushbutton contacts on the signal connector are shorted to common.
Display sequence does not function as expected.	Check: 1. Verify sequence selection as shown on page 20. 2. Check that no external pushbutton contacts on the input connector are shorted.
If the display locks up or the unit does not respond at all	Cycle the power to restart the microprocessor.
Relay operation is reversed	Check: 1. Fail-safe settings as shown on page 23. 2. Wiring of relay contacts
Other symptoms not described above	Call Technical Support for assistance.

To reset unit to factory default settings of sequence F2A-1, first out indication with silence and acknowledge pushbuttons with automatic reset, see page 27.

FULL SEQUENCE DESCRIPTIONS

The following section describes the operation of the various sequences available in the Vigilante® II alarm annunciator.

Features

Acknowledge Pushbutton: Momentary alarms will not clear until the alarmed channels have been acknowledged with the **ACK** pushbutton. This will also reset the first out indication. Used in all ISA sequences.

Automatic Reset: Acknowledged momentary alarms will clear automatically when the inputs return to normal. The automatic reset is present in all automatic (A) sequences.

First-Out Indication: The sequence provides a distinct visual indication for the first channel to alarm.

First-Out Reset Pushbutton: Resets the first-out display and assigns the first-out channel to display as a subsequent alarm without any other changes to the sequence. The next alarm input will be a new first-out alarm. Used only in sequence F3A.

Reset Pushbutton: Acknowledged momentary alarms will only clear when reset with the **RESET** pushbutton. Used in any manual reset (M) sequence.

Sequence Condition Descriptions

The following terms are used in describing the sequence behavior in the following tables:

Alert: The input is in alarm state, and the channel has not been acknowledged with the **ACK** pushbutton.

Acknowledge: The alarm state is acknowledged with the **ACK** pushbutton. This will restart the first-out indication.

First Out Reset (F3A Only): The **RESET** pushbutton is used to reset the first-out indication only.

Normal: Inputs are in the normal state.

LED Condition Descriptions

1st Pt: Indicates the behavior of the first-out channel only.

Next Pt: The behavior of subsequent alarm channels; channels that enter the alarm state after the first-out alarm.

ISA Sequence A

Acknowledge Pushbutton and Automatic Reset

Momentary Alarm

Condition	LED	Horn
Normal	Off	Off
Alert	Flash	On
Normal	Flash	On
ACK Pushbutton		
Acknowledge	Off	Off

Maintained Alarm

Condition	LED	Horn
Normal	Off	Off
Alert	Flash	On
ACK Pushbutton		
Acknowledge	Steady	Off
Normal	Off	Off

Sequence A Switch Positions



Sequence A Flowchart

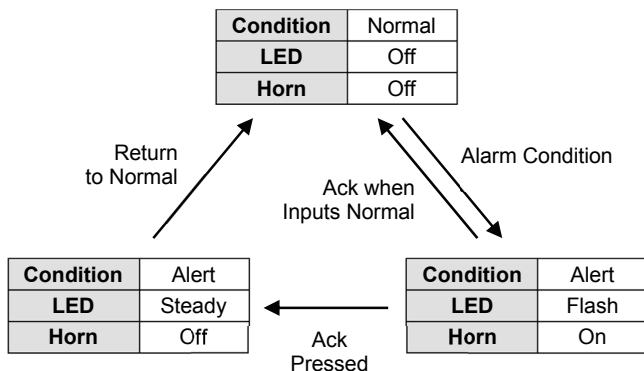

Relay Operation

For complete details on relay function, see page 23.

Relay 1: Operation

Relay 1 enters alarm state when there is a new alarm. This relay will clear when the alarms are acknowledged.

Relay 2 Operation

Relay 2 enters alarm state when any channel displays in alarm state. This relay will clear when all indication LEDs are cleared.

ISA Sequence F2A

First-Out Indication with Acknowledge Pushbutton and Automatic Reset

Momentary Alarm

Condition	LED		Horn
	1 st Pt	Next Pt	
<i>Normal</i>	Off	Off	Off
<i>Alert</i>	Flash	Steady	On
<i>Normal</i>	Flash	Steady	On
ACK Pushbutton			
<i>Acknowledge</i>	Off	Off	Off

Maintained Alarm

Condition	LED		Horn
	1 st Pt	Next Pt	
<i>Normal</i>	Off	Off	Off
<i>Alert</i>	Flash	Steady	On
ACK Pushbutton			
<i>Acknowledge</i>	Steady	Steady	Off
<i>Normal</i>	Off	Off	Off

Sequence F2A Switch Positions



Sequence F2A Flowchart

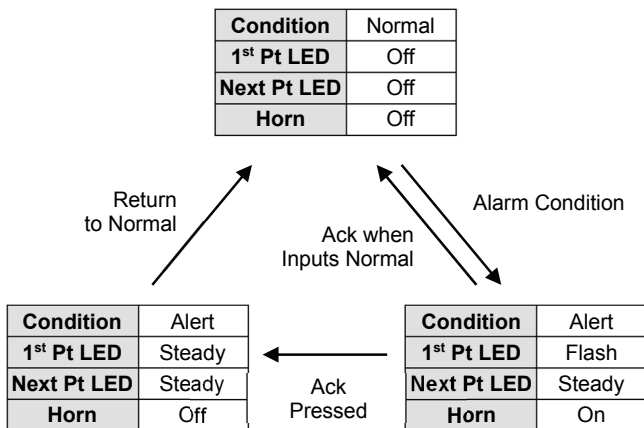

ISA Sequence F1A

First-Out Indication with Acknowledge Pushbutton, No Lock-In of Subsequent Alarms, and Automatic Reset

Momentary Alarm

Condition	LED		Horn
	1 st Pt	Next Pt	
<i>Normal</i>	Off	Off	Off
<i>Alert</i>	Flash	Steady	On
<i>Normal</i>	Flash	Off	On
ACK Pushbutton			
<i>Acknowledge</i>	Off	Off	Off

Maintained Alarm

Condition	LED		Horn
	1 st Pt	Next Pt	
<i>Normal</i>	Off	Off	Off
<i>Alert</i>	Flash	Steady	On
ACK Pushbutton			
<i>Acknowledge</i>	Steady	Steady	Off
<i>Normal</i>	Off	Off	Off

Sequence F1A Switch Positions



Sequence F1A Flowchart

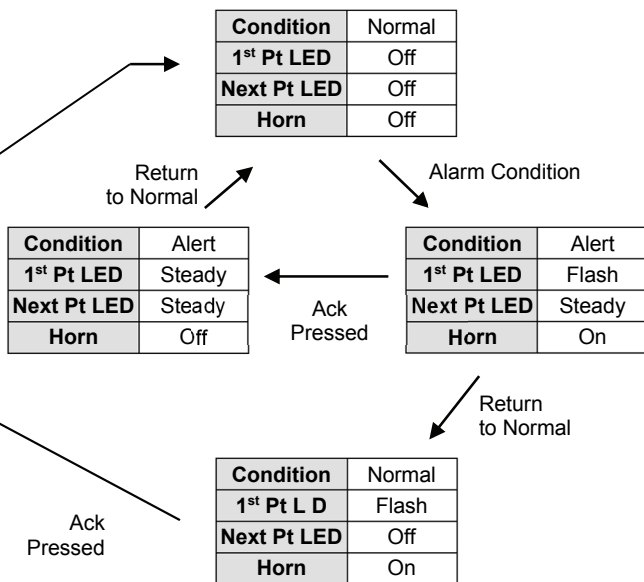

ISA Sequence F3A

First-Out Indication with Acknowledge Pushbutton, Automatic Reset, and First-Out Reset Pushbutton

Momentary Alarm (RESET before ACK)

Condition	LED		Horn
	1 st Pt	Next Pt	
<i>Normal</i>	Off	Off	Off
<i>Alert</i>	Intermittent Flash	Fast Flash	On
<i>Normal</i>	Intermittent Flash	Fast Flash	On
RESET Pushbutton			
<i>1st Out Reset</i>	Fast Flash	Fast Flash	On
ACK Pushbutton			
<i>Acknowledge</i>	Off	Off	Off



**Sequence
F3A
Switch
Positions**

Momentary Alarm (ACK before RESET)

Condition	LED		Horn
	1 st Pt	Next Pt	
<i>Normal</i>	Off	Off	Off
<i>Alert</i>	Intermittent Flash	Fast Flash	On
<i>Normal</i>	Intermittent Flash	Fast Flash	On
ACK Pushbutton			
<i>Acknowledge</i>	Slow Flash	Off	Off
RESET Pushbutton			
<i>Reset</i>	Off	Off	Off

Maintained Alarm (RESET before ACK)

Condition	LED		Horn
	1 st Pt	Next Pt	
<i>Normal</i>	Off	Off	Off
<i>Alert</i>	Intermittent Flash	Fast Flash	On
RESET Pushbutton			
<i>1st Out Reset</i>	Fast Flash	Fast Flash	On
ACK Pushbutton			
<i>Acknowledge</i>	Steady	Steady	Off
<i>Normal</i>	Off	Off	Off

Maintained Alarm (ACK before RESET)

Condition	LED		Horn
	1 st Pt	Next Pt	
<i>Normal</i>	Off	Off	Off
<i>Alert</i>	Intermittent Flash	Fast Flash	On
ACK Pushbutton			
<i>Acknowledge</i>	Slow Flash	Steady	Off
RESET Pushbutton			
<i>1st Out Reset</i>	Steady	Steady	Off
<i>Normal</i>	Off	Off	Off



Sequence F3A Flowchart
Switch Positions

Sequence F3A

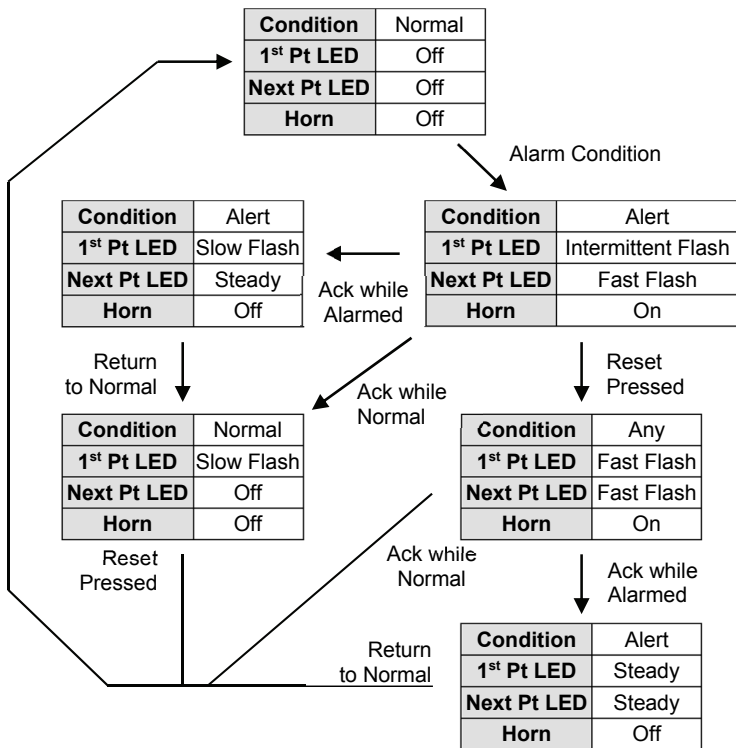

Input Follower Indication

Simple Indication

Condition	LED	Horn
<i>Normal</i>	Off	Off
<i>Alert</i>	Steady	On
<i>Normal</i>	Off	Off

Switch Positions



ISA Sequence M

Acknowledge and Reset Pushbuttons

Momentary Alarm

Condition	LED	Horn
<i>Normal</i>	Off	Off
<i>Alert</i>	Flash	On
<i>Normal</i>	Flash	On
ACK Pushbutton		
<i>Acknowledge</i>	Steady	Off
RESET Pushbutton		
<i>Reset</i>	Off	Off

Maintained Alarm

Condition	LED	Horn
<i>Normal</i>	Off	Off
<i>Alert</i>	Flash	On
ACK Pushbutton		
<i>Acknowledge</i>	Steady	Off
<i>Normal</i>	Steady	Off
RESET Pushbutton		
<i>Normal</i>	Off	Off

Sequence M

Switch Positions



Sequence M Flowchart

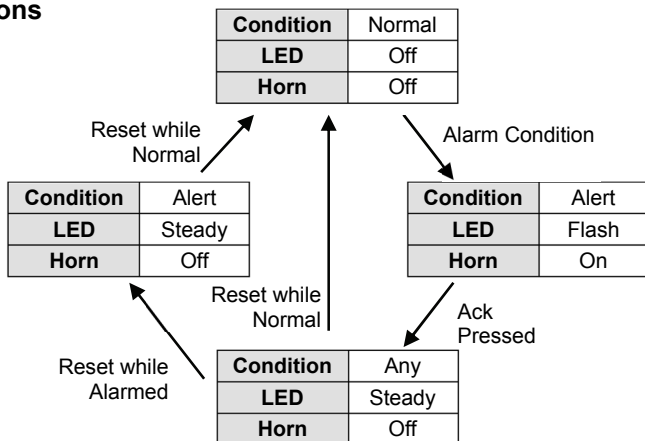

ISA Sequence F1M

First-Out Indication with Acknowledge and Reset Pushbuttons, and No-Lock-In of Subsequent Alarms

Momentary Alarm

Condition	LED		Horn
	1 st Pt	Next Pt	
<i>Normal</i>	Off	Off	Off
<i>Alert</i>	Flash	Steady	On
<i>Normal</i>	Flash	Steady	On
RESET Pushbutton			
<i>Reset</i>	Flash	Off	On
ACK Pushbutton			
<i>Acknowledge</i>	Steady	Off	Off
RESET Pushbutton			
<i>Normal</i>	Off	Off	Off

Maintained Alarm

Condition	LED		Horn
	1 st Pt	Next Pt	
<i>Normal</i>	Off	Off	Off
<i>Alert</i>	Flash	Steady	On
RESET Pushbutton			
<i>Alert</i>	Flash	Steady	On
ACK Pushbutton			
<i>Acknowledge</i>	Steady	Steady	Off
<i>Normal</i>	Steady	Steady	Off
RESET Pushbutton			
<i>Normal</i>	Off	Off	Off

Sequence F1M Switch Positions



Sequence F1M Flowchart

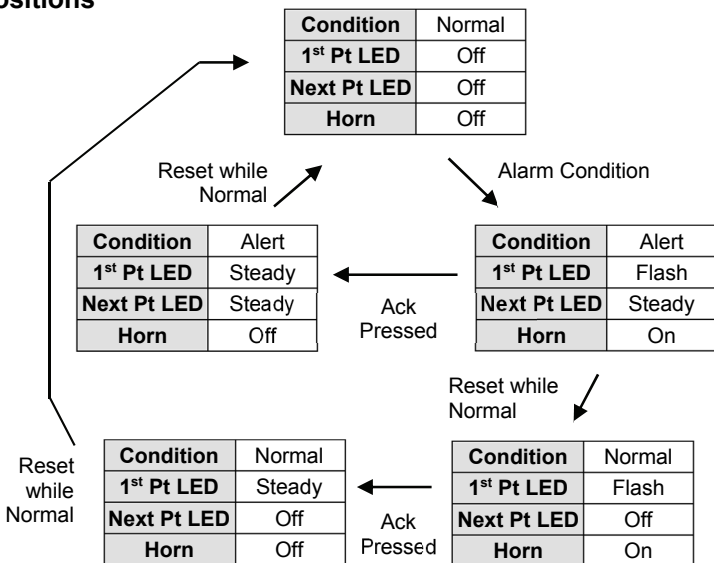

ISA Sequence F2M

First-Out Indication with Acknowledge and Reset Pushbuttons

Momentary Alarm

Condition	LED		Horn
	1 st Pt	Next Pt	
<i>Normal</i>	Off	Off	Off
<i>Alert</i>	Flash	Steady	On
<i>Normal</i>	Flash	Steady	On
ACK Pushbutton			
<i>Acknowledge</i>	Steady	Steady	Off
RESET Pushbutton			
<i>Reset</i>	Off	Off	Off

Maintained Alarm

Condition	LED		Horn
	1 st Pt	Next Pt	
<i>Normal</i>	Off	Off	Off
<i>Alert</i>	Flash	Steady	On
ACK Pushbutton			
<i>Acknowledge</i>	Steady	Steady	Off
<i>Normal</i>	Steady	Steady	Off
RESET Pushbutton			
<i>Normal</i>	Off	Off	Off

Sequence F2M Switch Positions



Sequence F2M Flowchart

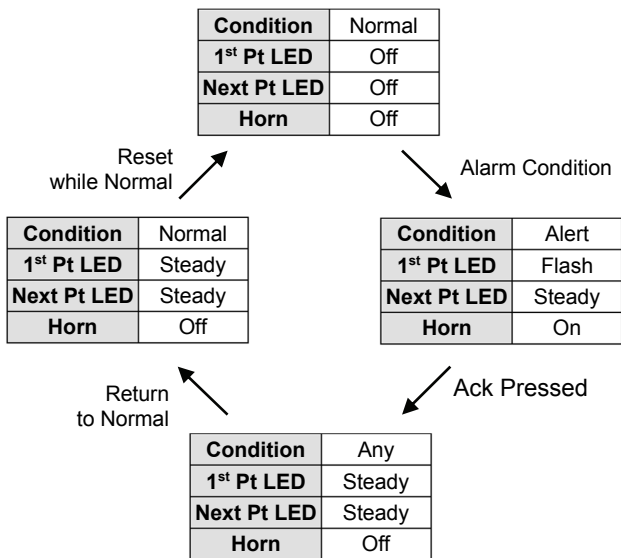

EU DECLARATION OF CONFORMITY

Issued in accordance with ISO/IEC 17050-1:2004.

We,

**Precision Digital Corporation
233 South Street
Hopkinton, MA 01748 USA**

as the manufacturer, declare under our sole responsibility that the product(s),

Model PD154 & PD158 Vigilante® Series

to which this declaration relates, is in conformity with the European Union Directives shown below:

2014/35/EU	Low Voltage Directive
2014/30/EU	EMC Directive
2011/65/EU	RoHS Directive

This conformity is based on compliance with the application of harmonized or applicable technical standards and, when applicable or required, a European Union notified body certification.

Standards:

EN 55022:2003
EN 61000-6-2:2001
EN 61010-1:2001
EN 61326:2006

The standards EN 55022:2003, EN 61000-6-2:2001, EN 61010-1:2001, and EN 61326:2006 are no longer harmonized. The requirements of these standards have been checked against the harmonized standards EN 55022:2010, EN 61000-6-2:2005, EN 61010-1:2010, and EN 61326:2013 and there were no major technical changes affecting the latest technical knowledge for the products listed above.

Product Markings: 

Signed for and on behalf of Precision Digital Corporation:



Name: Jeffrey Peters
Company: Precision Digital Corporation
Title: President
Date: 04/20/2016



Document No: DoC PD158 {042016}

How to Contact Precision Digital

- For Technical Support please
Call: (800) 610-5239 or (508) 655-7300
Fax: (508) 655-8990
Email: support@predig.com
- For Sales Support or to place an order please
Call: (800) 343-1001 or (508) 655-7300
Fax: (508) 655-8990
Email: sales@predig.com
- For the latest version of this manual please visit
www.predig.com

