

PD9000 ConsoliDator+ Multivariable Controller

Instruction Manual



- NEMA 4X Panel Mount Multi-Channel Controller
- Convenient Display, Control, & Alarm of Multiple 4-20 mA & Pulse Inputs
- Numeric & Bargraph Color Display (320 x 240 px) 5.7" (145 mm)
- Sunlight Readable Display, White Backlight
- Isolated 24 VDC Transmitter Supplies 200 mA / Analog Input; 1,600 mA Max
- 99 Channels, 32 Totalizers, 32 Timers, & 199 Modbus Slave Inputs
- 64 High & Low Alarms, Combine Multiple Alarms Into Logic AND & OR Alarms
- Simulation & Manual Control Modes for Testing Setup
- Modular Design for Input & Output Flexibility
- Up to (28) 4-20 mA Isolated Inputs or Pulse Inputs
- Up to (25) 10 Amp Form C Relays (With Eight Analog or Pulse Inputs)
- Up to (25) Isolated 4-20 mA Outputs (With Eight Analog or Pulse Inputs)
- Operating Temperature Range: -40 to 60°C (-40 to 140°F)
- Pulse, Analog, & Modbus Input Flow Rate / Total / Grand Total Capability
- 50-Point Linearization, Square Root, and Exponent for Open Channel Flow
- Round Horizontal Tank Volume Calculation; Just Enter Diameter & Length
- Multi-Pump Alternation Control or Simple On / Off Control
- Programmable Displays, Function Keys & Digital Inputs
- Math Functions: Sum, Diff, Average, Multiply, Divide, % Efficiency, & More
- Direct Modbus PV Inputs - Slave Mode
- Customize Modbus Outputs to Read Multiple Registers in One Block
- RS-485 Serial Communication with Modbus RTU
- Field Selectable Input Power: 85-264 VAC or 24 VDC
- (20) Screens with up to Eight PVs Each
- Automatic or Manual Scanning
- ConsoliDator+ Configuration Software
- NEMA 4 Field Mount Enclosure Accessory
- Light / Horn & Control Station Accessory for Remote Operation
- 3-Year Warranty

PRECISION DIGITAL CORPORATION

233 South Street • Hopkinton MA 01748 USA

Tel (800) 343-1001 • Fax (508) 655-8990

www.predig.com



Disclaimer

The information contained in this document is subject to change without notice. Precision Digital makes no representations or warranties with respect to the contents hereof and specifically disclaims any implied warranties of merchantability or fitness for a particular purpose. See Warranty Information and Terms & Conditions on www.predig.com for complete details.

CAUTION

- Read complete instructions prior to installation and operation of the controller.

WARNINGS

- Risk of electric shock or personal injury.
- This product is not recommended for life support applications or applications where malfunctioning could result in personal injury or property loss. Anyone using this product for such applications does so at his/her own risk. Precision Digital Corporation shall not be held liable for damages resulting from such improper use.

WARNING
Cancer and Reproductive Harm - www.P65Warnings.ca.gov

Limited Warranty

Precision Digital Corporation warrants this product against defects in material or workmanship for the specified period under "Specifications" from the date of shipment from the factory. Precision Digital's liability under this limited warranty shall not exceed the purchase value, repair, or replacement of the defective unit. See Warranty Information and Terms & Conditions on www.predig.com for complete details.

Registered Trademarks

All trademarks mentioned in this document are the property of their respective owners.

© 2020 Precision Digital Corporation.
All rights reserved.

FREE ConsoliDator+ Configuration Software



The easiest and quickest way to program your ConsoliDator+ multivariable controller is to use the FREE ConsoliDator+ configuration software.

The ConsoliDator+ configuration software is intuitive, and most customers can get their controller programmed as they like without even looking in the manual.

Once your controller is programmed the way you want it, you can wire it up for your application per the instructions in this manual and install it. If you find that you need to adjust the programming after the controller is installed, you can use the front panel soft keys and the instructions in this manual to do so.

Table of Contents

Introduction.....	6
Ordering Information.....	6
Input / Output Cards	7
Setup & Calibration Services	7
Accessories.....	7
Specifications	10
General	10
Totalizer	11
Real Time Clock	11
Channel & Math Functions.....	12
List of Engineering Units	12
4-20 mA Analog Inputs	13
Pulse Inputs	13
Modbus Inputs	13
Digital Inputs & Outputs.....	14
Relays	14
4-20 mA Transmitter Outputs	15
Timers.....	15
Modbus® Serial Communications.....	15
Ethernet Communications	15
ConsoliDator+ Software	15
Safety Information	16
Installation.....	16
Unpacking	16
Panel Mounting	16
Mounting Dimensions	17
ConsoliDator+ Configuration Software Installation.....	18
ConsoliDator+ Software	19
Connections.....	20
Power Connections	21
Analog Output Connections.....	22
Digital Output Connections.....	22
Connections to Power Gas Detector	23
Serial Communication Connections	24
External Keypad Connections	24
Navigating and Editing.....	25
Soft-Keys and Buttons	25
Setup and Programming.....	26
Overview.....	26
Setup Menu	27
Channel Parameters	28
Data Entry Keypad.....	29
Setup Channels.....	30
Create New Channel	31
Bargraph, Background & Text Colors.....	32
Live Calibration.....	33
Edit Channel.....	33
Delete Channel.....	33
2-Point Linear Scaling	34
Square Root Scaling	34
Scale Exponent	35
Round Horizontal Tank.....	35
Open Channel Flow Application	36
Setup Math Functions	37
Setup Totalizers	38
Setup Total with Pulse Input Source	38

Setup Timers	39
Setup Alarms	40
Logic OR Alarm	41
Logic AND Alarm	41
Logic NOR & NAND Alarms	41
Setup Inputs	42
Setup 4-20 mA Inputs	42
Setup Pulse Inputs	43
Setup Digital Inputs	43
Setup Modbus Inputs	44
Setup All Outputs.....	45
Setup 4-20 mA Outputs	45
Setup Relay Output	46
Setup Digital Output	48
Setup Modbus Output	48
Setup Screens	49
Screens Settings	49
Setup System	51
Setup Display	51
Setup Colors.....	51
Display Settings.....	51
General Settings.....	52
Set Password	52
Password Protected Controller.....	52
Remove Password Protection	52
System Date & Time	53
Modbus Settings & Passcode Protection	53
System Build	53
Ethernet Settings.....	53
Ethernet Port Setup - Full	54
Test Ethernet Communication	56
Custom Units.....	57
View Menu	58
View Channel Details	58
View Totals.....	60
Totals Generated by Non-Rate Inputs.....	61
View Timers.....	62
View Alarms	63
View Inputs.....	64
View Outputs.....	65
View Alert Messages.....	66
View Digital Outputs	67
View Modbus Outputs	67
View Screens	68
Operation.....	69
Viewing Screens	69
Individual Channel View	69
Low & High Alarm Indication	69
Multicolor Bargraph Indication.....	70
Modbus® RTU Serial Communication	71
Modbus Register Tables	71
PV's Register Numbers & Addresses	73
Modbus Write Protection	74
Relay Control Using Modbus	78
Setup Example #1	78
Setup Example #2	78
Troubleshooting Tips.....	79

Table of Figures

Figure 1. Front Panel Mount Dimensions	16
Figure 2. Panel Cutout Dimensions	16
Figure 3. Panel Mount Installation	17
Figure 4. Panel Mount Overall Dimension	17
Figure 5. Connection Terminals for a PD9000-GP-4PI-8AI-10AO-10RY	20
Figure 6. Power Connections	21
Figure 7. Transmitters Powered by ConsoliDator+ Isolated 24 VDC Power Supply	21
Figure 8. Transmitter Powered by Ext. Supply or Self-Powered	21
Figure 9. 3-Wire Transmitters Powered Externally	21
Figure 10. Flow Meter Pulse Input Connections	22
Figure 11. Digital Input from Switch Closure and Live Signal	22
Figure 12. Active 4-20 mA Output Powered by Controller	22
Figure 13. Passive 4-20 mA Output Powered by External Supply	22
Figure 14. Digital Outputs Driving 5 V Solid State Relay	22
Figure 15. Two Supplies in Parallel Powering 3-Wire Transmitter	23
Figure 16. Powering 4-Wire Gas Detector & Isolated 4-20 mA Output	23
Figure 17. Relay Connections	24
Figure 18. AC and DC Internal Inductive Loads Protection	24
Figure 19. Low Voltage DC Loads Protection	24
Figure 20. Serial Connections	24
Figure 21. External Keypad Connections	24
Figure 22. Linear Response Graph	34
Figure 23. Square Root Response Graph	34
Figure 24. Exponent Response Graph	35
Figure 25. Round Horizontal Tank Volume Graph	35
Figure 26. Total Relay Sampling Operation	36

Introduction

The ConsoliDator+ is a multi-channel controller that is both easy to use and satisfies a wide variety of process display, alarm, and control applications. It accepts 4-20 mA inputs, flow meter pulse inputs, digital inputs, and Modbus RTU inputs and displays them both in numeric and bargraph format on a large, 5.7" color display. It can be equipped with multiple relays with user-definable actions, 4-20 mA outputs, digital outputs, Modbus RTU, and Ethernet Modbus TCP/IP protocol communication capabilities. Additionally, the controller is equipped with up to 32 timers that can be used to control many processes or events.

The ConsoliDator+ takes full advantage of its color display by allowing the user to customize screen colors for bargraphs, alarm conditions, and input channels.

All this functionality is easily programmed using free software or via the front panel pushbuttons. Choose the model that best suits your application, from monitoring only to fully loaded controllers with an extensive combination of inputs, outputs and communication protocols. The standard product offering is listed in the ordering guide and other models are available for special order.

Ordering Information

General Purpose Panel-Mount Models				
Model	Pulse Inputs	4-20 mA Inputs	4-20 mA Outputs	Relays
PD9000-GP-4AI	0	4	0	0
PD9000-GP-4AI-10RY	0	4	0	10
PD9000-GP-4AI-5AO-10RY	0	4	5	10
PD9000-GP-4AI-20RY	0	4	0	20
PD9000-GP-4AI-5AO-20RY	0	4	5	20
PD9000-GP-8AI	0	8	0	0
PD9000-GP-8AI-10RY	0	8	0	10
PD9000-GP-8AI-10AO-10RY	0	8	10	10
PD9000-GP-8AI-20RY	0	8	0	20
PD9000-GP-8AI-25RY	0	8	0	25
PD9000-GP-12AI	0	12	0	0
PD9000-GP-12AI-20RY	0	12	0	20
PD9000-GP-12AI-10AO-10RY	0	12	10	10
PD9000-GP-16AI	0	16	0	0
PD9000-GP-16AI-15RY	0	16	0	15
PD9000-GP-16AI-15AO	0	16	15	0
PD9000-GP-20AI	0	20	0	0
PD9000-GP-20AI-10RY	0	20	0	10
PD9000-GP-20AI-10AO	0	20	10	0
PD9000-GP-24AI	0	24	0	0
PD9000-GP-24AI-5RY	0	24	0	5
PD9000-GP-24AI-5AO	0	24	5	0
PD9000-GP-28AI	0	28	0	0
PD9000-GP-4PI	4	0	0	0
PD9000-GP-4PI-5AO	4	0	5	0
PD9000-GP-4PI-5AO-10RY	4	0	5	10
PD9000-GP-4PI-4AI-5AO	4	4	5	0
PD9000-GP-4PI-4AI-5AO-10R	4	4	5	10
PD9000-GP-4PI-8AI-10AO-10RY	4	8	10	10
PD9000-GP-8PI	8	0	0	0
PD9000-GP-8PI-10AO	8	0	10	0
PD9000-GP-8PI-10AO-10RY	8	0	10	10
PD9000-GP-8PI-8AI-10AO-5RY	8	8	10	5

G = General Purpose
 P = Panel-Mount
 AI = Analog Input
 PI = Pulse Input

AO = Analog Output
 RY = Relay
 E = Ethernet (Add “-E” at the end of the model number)
 Example: PD9000-GP-4PI-8AI-10AO-10RY-E

Other models are available upon request.

Input / Output Cards

Model	Description
PDA9000-C4AI	(4) Isolated 4-20 mA Inputs Card for ConsoliDator+
PDA9000-C4PI	(4) Pulse Inputs Card for ConsoliDator+
PDA9000-C5AO	(5) Isolated 4-20 mA Outputs Card for ConsoliDator+
PDA9000-C5RY	(5) Relays Card for ConsoliDator+

Setup & Calibration Services

Part Number	Description
PDN-CALCON+12	ConsoliDator+ Calibration and Certificate for up to 12 Inputs and Outputs
PDN-CALCON+24	ConsoliDator+ Calibration and Certificate for up to 24 Inputs and Outputs
PDN-CALCON+36	ConsoliDator+ Calibration and Certificate for up to 36 Inputs and Outputs
PDN-CALCON+12-DATA	ConsoliDator+ Calibration and Certificate with data for up to 12 Inputs and Outputs
PDN-CALCON+24-DATA	ConsoliDator+ Calibration and Certificate with data for up to 24 Inputs and Outputs
PDN-CALCON+36-DATA	ConsoliDator+ Calibration and Certificate with data for up to 36 Inputs and Outputs
PDN-CSETCON+	Custom Setup for ConsoliDator+

Accessories

NEMA 4 Steel Enclosure



Model	Description
PDA2909	NEMA 4 Steel Enclosure for One ConsoliDator+

PDA9000SH Sun Hood



Model	Description
PDA9000SH	ConsoliDator+ Sun Hood

Light / Horn Accessories



Model	Description
PDA-LHR	Red Light / Horn
PDA-LHG	Green Light / Horn
PDA-LHY	Yellow Light / Horn
PDA-LHB	Blue Light / Horn
PDA-LHW	White Light / Horn
PDA-LH5C	Light / Horn with User Choice of Red, Green, Yellow, Blue or White Light
PDA-LH3LC-RYG	Light / Horn with Red, Yellow, Green Light Layers

PDA2360 Control Stations



Model	Description
PDA2360-E	Emergency Stop Button
PDA2361-A	1 Black Ack Button
PDA2361-Q	1 Black Silence Button

Signal Splitter & Conditioner Accessories



Model	Description
PD659-1MA-1MA	Signal Isolator with One 4-20 mA Input and One 4-20 mA Output
PD659-1MA-2MA	Signal Splitter with One 4-20 mA Input and Two 4-20 mA Outputs
PD659-1V-1MA	Signal Conditioner with One 0-10 VDC Input and One 4-20 mA Output
PD659-1MA-1V	Signal Conditioner with One 4-20 mA Input and One 0-10 VDC Output

PDA1024-01 Power Supply

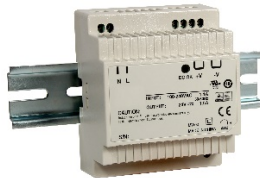

Model	Description
PDA1024-01	24 VDC Power Supply for DIN Rail

Split Core AC Current Transducer



Model	Description
PDA6420	Split Core AC Current Transducer. Input: 30/60/120 AAC; Output 4-20 mA

PDA-BUTTON Momentary Pushbutton



Model	Description
PDA-BUTTON1B	NEMA 4X Black Reset Button
PDA-BUTTON1G	NEMA 4X Green Reset Button
PDA-BUTTON1R	NEMA 4X Red Reset Button

Panel Mount Buzzer and Light



Model	Description
PDA1000	Panel Mount Buzzer and Light

Snubber 0.01µF/470Ω Flexible Leads



Model	Description
PDX6901	Snubber 0.01µF/470Ω Flexible Leads

Low-Cost Signal Generator



Model	Description
PD9502	4-20 mA or 0-10 VDC, Low-Cost Signal Generator

PDA2909 NEMA 4 Steel Enclosure for One ConsoliDator+

The PDA2909 steel NEMA 4 enclosure provides a convenient way to mount the PD9000 ConsoliDator+ to walls and other vertical structures. This enclosure comes pre-cut with one cutout to mount the PD9000 in. The ConsoliDator+ is mounted in the door of the enclosure thus allowing for programming and operation of the device. No additional mounting hardware other than screws to mount to the wall is needed. The door is hinged and secured with latches.

Note: The enclosure and ConsoliDator+ are ordered and packaged separately.



PDA2909 with ConsoliDator+ Installed



PDA2909 Opened with ConsoliDator+ Installed

[Visit predig.com/PDA2909](http://predig.com/PDA2909) for more details

Features

- House One ConsoliDator+ Multi-Variable Controller
- 14-Gauge Steel
- Comes Pre-Cut with One Cutout
- NEMA 4, 12 and 13
- Cover Secured with Screwed Latches
- Hinged Door
- ConsoliDator+ Mounted in Cover
- Mounting Holes Integral to Enclosure
- UL Listed, CSA Certified

Wall Mounting Dimensions:

The PDA2909 enclosure includes integral mounting flanges at the top and bottom of the enclosure that can be used to mount the enclosures to a wall.

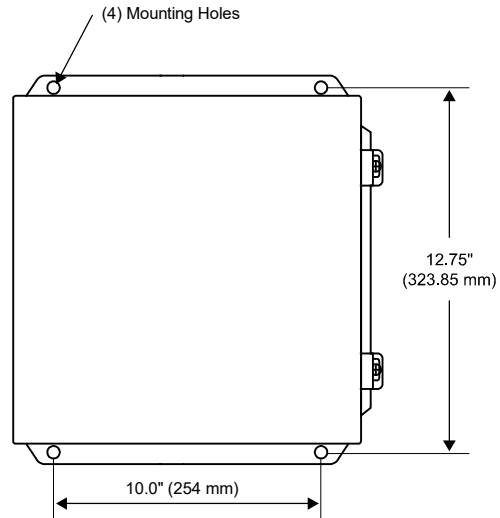

PDA2909 Overall Dimensions:

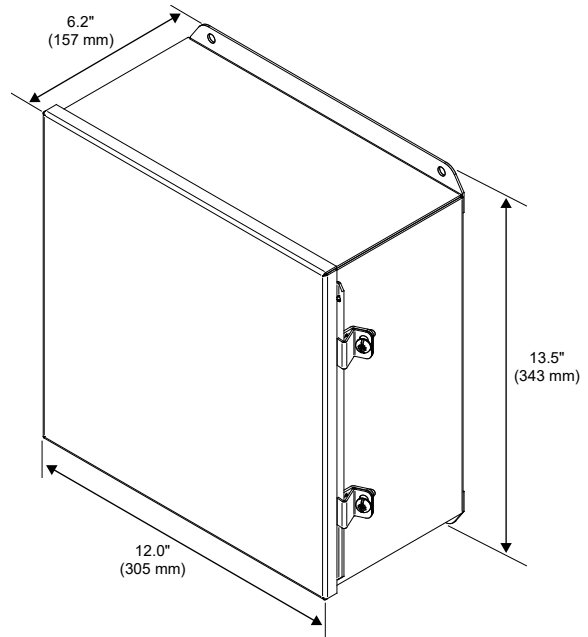

Specifications

Except where noted all specifications apply to operation at 25°C (77°F)

General

Display	Color; QVGA (320x240 px), 5.7" (145 mm) diagonally, white backlight Bargraph: Twenty divisions Numerical: Up to 15 digits (±999,999,999,999,999) Feet & Inches Format: 99,999' 11.9"
Screen Bargraph	Enable/disable: Channels, totals, timers Bargraph scale: 0 – 100%, independent of channel scale. Twenty divisions: 5% each. Screen: Select to show bargraph or not.
Color Selection	65 colors selection Customize bargraph, panel background, and text for normal and alarm conditions.
Decimal Point	0 to 15 decimal places, user selectable
Engineering Units	User selectable units or custom units Time, Distance, Volume, Pressure, Weight, Temperature, Current, Voltage, Percent, Amps, Volts, Counts, Logic, and Custom, Any unit/unit of time or other units. See page 12 for list of units.
Units Conversion	Units' conversion is supported for channels, totals, timers, and any function using those parameters. Channel scaling must be in the intended base units (e.g. Gallons/min)
Display Update Rate	User selectable: 0.1 to 0.5 sec (10 updates/sec to 2 updates/sec)
Programming Method	Front panel buttons, external buttons, or ConsoliDator+ Software
Number Of Alarms	Up to 64 high or low Automatic (non-latching) or latching On & Off time delays May be assigned to one or more relays. <i>Note: Alarms are independent from relays.</i>
Alarm Types	Single Source: One input Multi-Source: Two or more inputs Interval: Enter time interval and On Time Day & Time: Select day of the week & time Alarm OR: Any active input alarm triggers the OR alarm Alarm AND: All alarms must be active to trigger the AND alarm
Alarm Ack & Reset	Automatic only (Non-latching) Automatic and manual Manual only (Latching) Manual with Ack only after alarm is cleared (Latching with Clear)
Alarm Indication	1. Bargraph, panel, and text can be set up to change color on alarm 2. Enable internal buzzer 3. Assign external relay to drive a horn
Internal Buzzer	60 dBA @ 24 inches (61 cm) Enable/disable in System – General menu. Associated with alarm Horn setting
External Horn (Sold Separately)	Assign any relay to the Horn function to activate an external horn when alarm condition is detected.
Live Channel Calibration	Live calibration of channels is independent of the input calibration used for scaling.

Input & Output Cards	Max Number of I/O Cards: 7 Analog Inputs: 4/card Pulse Inputs: 4/card Analog Outputs: 5/card Relays: 5/card
Number of Screens	Up to 20 screens with 1 to 8 PVs or items per screen Enable or disable screen title, channel #, and bargraph Automatic or manual scanning Scan time: 1 to >1000 sec, independent for each screen F1-F4 keys are assigned per screen
Function Keys	User programmable (See defaults below) F1 = Previous ← F2 = Next → F3 = Scan/Stop F4 = Ack
Number of Channels	Up to 99 channels Input Source: 4-20 mA, Pulse, Digital, Modbus, another Channel, Total, Timer, Alarm, Date & Time, mA Output, Relay Output, Digital Output, or Modbus Output
Password	Programmable password restricts modification of programmed settings. View and Setup menus are password protected, function keys and digital inputs are not protected.
Simulation Mode	Inputs, channels, totals, timers, and alarms can be simulated from the View menu or from a function key. Simulation mode is not saved on power down. Alert! message is provided for simulated items.
Manual Control	Analog outputs and relays can be controlled manually from the View menu or from a function key. Manual control mode is not saved on power down. Alert! message is provided for outputs in manual control. <i>Note: If it is necessary to turn relays off and maintain the condition through power cycle, configure the relays to Always Off.</i>
Non-Volatile Memory	Settings stored for a minimum of 10 years.
Power	Three-terminal connector (L, N, GND) AC: 80-264 VAC, 47 to 63 Hz, 60 W max DC: 113-370 VDC, 60 W max (L, N)
User Selectable Based on Wiring	Two-terminal connector (G, 24V) DC: 24 VDC ±10%, 60 W max
Backup Power Supply	If AC and DC power are connected, the 24 VDC can be used as backup power in case of AC power failure. <i>Note: DC supply must be 24 V or less; otherwise the system runs on DC power.</i>
Fuse	Unit is protected internally with auto-resettable fuse AC: 1.25 A max DC: 3.7 A max

External Fuse	Recommended external fuse slow-blow 120 VAC: 2.0 A 240 VAC: 1.0 A 24 VDC: 4 A
Isolation & Grounding	1500 V Analog inputs/outputs-to-power line 500 V Analog input-to-input, input-to-output, analog output-to-output All analog inputs and analog outputs are isolated from each other. <i>Note: DC Power is not isolated. DC- is connected to Earth Ground. Digital I/O, USB, and Ethernet are grounded.</i>
Environmental	Operating temperature range: -40 to 60°C (-40 to 140°F) Storage temperature range: -40 to 60°C (-40 to 140°F) Relative humidity: 0 to 90% non-condensing <i>*All functions operate down to -40°C (-40°F.) LCD response is slower, increase display refresh setting.</i>
Internal Fan	Automatic temperature-controlled fan turns on if the inside temperature reaches 50°C and increases the speed as the temperature rises to 60°C.
Internal Heater	Automatic temperature-controlled heater located behind the LCD turns on at 0°C, delivering the minimum power. If the temperature drops below -10°C, the heater delivers its maximum power.
Connections	Removable screw terminal blocks Inputs/Outputs: 12 to 24 AWG wire Digital I/O: 16 to 30 AWG RS-485: 12 to 24 AWG wire RJ45 Ethernet connection. USB ports: Micro-USB (Device), cable included.
Tightening Torque	Screw terminal connectors: 5 lb-in (0.56 Nm) Digital I/O terminals: 2.5 lb-in (0.28 Nm)
Enclosure	Enclosure Body: Thermoplastic Polyester, Color: Gray Display Window: Clear Polycarbonate, GE LEXAN HP12W Front Panel Keys: Silicone rubber
Mounting	Panel-mounting frame and twelve screws (provided) Cutout: 10.0" x 10.0" ±0.05" (254 mm x 254 mm ±1.3 mm) (H x W) Panel thickness: 0.07" – 0.35" (1.8 mm – 8.9 mm) Clearance behind panel: 6" (152 mm)
Overall Dimensions	10.85" x 10.85" x 4.87" (276 mm x 276 mm x 124 mm) (H x W x D)
Weight	Ex: PD9000-XY-4PI-8AI-10AO-10RY 7.4 lb (3.4 kg) approx.
Warranty	3 years parts and labor. See Warranty Information and Terms & Conditions on www.predig.com for complete details.

Totalizer

Number of Totalizers	Up to 32 totalizers 15 digits with comma separator
Totalizer Inputs	Calculates total based on selected rate channel, pulse input, digital input, or triggered event for non-rate channels. Total is stored in non-volatile memory if power is lost.
Maximum Total	18 digits 999,999,999,999,999,999
Rate Channel Input	4-20 mA input, Pulse input, Modbus input
Rate & Total Decimal Point	Independent and user selectable from 0 to 15 places
Totalizer Reset	Via front panel keys or digital inputs
Non-Resettable Total	Total may be setup to be non-resettable to prevent unintentional reset. This can be changed in the Setup Totals menu.
Total Units Conversion	Input: Rate channel Total units may be different than rate units. Use the custom units to convert to any unit (e.g. Gallons to MGal: Factor = 0.000001)
Pulse Input K-Factor	K-Factor = pulses/units of measure Calculates total directly from pulse input, digital input, or Modbus input. Create rate channel by entering K-Factor, units and time base in sec, min, hr, or day. Decimals: 0 to 15
Count Down	Total may be setup to count down from a predetermined value entered by the user
Preset Value	Enter the preset value to count up or down Reset total sets total to the preset value; to reset to zero uncheck the Preset box.
Roll-Over	Enter the value for total to roll-over to 0 Example: Roll-Over = 1,000,000 Total goes to 0 after 1 million
Negative Total	Allow total value to count below 0 for bi-directional flow based on rate channel
Total Bargraph	Bargraph may be scaled to represent the expected maximum total
Function Keys	Screen Setup: Assign F1-F4 to Reset Total, Enter Total, Add To, or Remove From total

Real Time Clock

Date Format	Month, day, year (e.g. July 16, 2020)
Time Format	24 hour; 00: Midnight hh:mm:ss
Battery	3 V, P/N: CR2032 included
Display Date & Time	Displayed on the top line of Setup and View menus, including day of the week.
Screens	Date & Time can be added to any screen.
Channels	Date & Time can be the input to a channel. Display Format: yyyy/mm/dd hh:mm:ss

Channel & Math Functions

Scale Functions	K-Factor	Converts number of pulses to volume or other units
	Scale Factor	Apply multiplier to a channel
	Scale Linear 2-Pt	Scale a channel
	Scale Multi-Point	Multi-point scaling of a channel
	Scale Square Root	Apply square root to a channel – Differential Pressure from two channels
	Scale Exponent	Apply exponent for weirs and flumes open channel flow calculation
	Round Horizontal Tank	Calculate volume in round horizontal tank with flat ends
	Units Conversion	Convert base units to any units
Math Functions	Constant	Assign fixed value
	Summation	Add two or more channels
	Difference	Subtract any two channels
	Abs Difference	Difference always positive
	Absolute Value	Convert channel value to positive
	Average	Find the average of channels
	Weighted Average	Assign % weight to two or more channels
	Multiply	Multiply two channels
	Divide	Divide two channels
	% Efficiency	Calculate input to output efficiency $((A-B)/A)*100\%$

Additional Functions	Compare	
	Greatest	Greatest value in a group of channels
	Least	Smallest value in a group of channels
	Measure	
	Tare	Calculate net value when Tare function is applied via function key
	Maximum	Maximum value reached by the process
	Minimum	Minimum value reached by the process
	Percent (Bargraph)	% bargraph of any: 4-20 mA input, channel, total, timer, or mA output
	Duration	Keep track of time a condition has been present (e.g. high alarm active)
	Rate of Change	Calculates how fast a process is changing /sec, /min, /hr, /day
	Filter	
	Window Average	Enter time to calculate the average
	IIR (First Order)	Infinite Impulse Response (slow)
	Cutoff	PV = 0 below cutoff Flip Side: 0 above (-)
	Limits	Sets PV's upper & lower limits.
	Control	
	Sampler	Trigger relay sample and select sampling time (e.g. Turn relay on for 30 sec every time total increases by 1,000 Gallons)
	On-Off Control	Set on & off control based on process value
	Select A or B	Switch between 2 inputs
	Schedule	Daily or weekly event
	Relays	
	Cycle Count	Number of relay cycles since reset
	Runtime	Relay runtime (ON) hh:mm:ss
	Modbus	
	Time Since Read	Time since a Modbus master device read a register
	Time Since Write	Time since a Modbus master wrote to a register

List of Engineering Units

None: No units
Time: seconds, minutes, hours, days & /sec, /min, /hr, /day
Distance (Height): cm, m, Inch, Feet, Ft-In, Yard, km, miles, custom
Volume: Gallons, GAL, L, IGAL, M3, BBL, BUSH, cuYD, cuFt, cuIn, LiBBL, BBBL, HECtL, quarts, pints, fl oz, mL, DT, M/T, custom
Pressure: psi, Pa, bar, hPa, kPa, MPa, GPa, inH2O, cmH2O, inHg, mmHg, atm, kg/cm2, kg/m2, mbar, Mbar, Torr, mTorr, custom
Weight: grams, Oz, Lb, lb, g, kg, ounces, tons, tonnes, custom
Temperature: C, F, K, Ra
Percent: %, PCT, Percent, custom
Amps: mA, Amps, custom
Volts: V, mV, Volts, custom
Counts: Pulses, Cycles, Counts, custom
Logic: ON, OFF, OPEN, CLOSED, YES, NO, START, RUNNING, STOP, STOPPED, PUMP ON, PUMP OFF, OK, OKAY, ERROR, WARNING, custom
Custom: Enter unit's name, type, base unit, and factor.

4-20 mA Analog Inputs

Number of Inputs	(4) Analog inputs/card (28) Analog inputs max, no other I/O
Typical Input	4-20 mA
Input Range	0-24 mA
Accuracy	±0.03% of full scale ±1 count
4-20 mA Display Value	Up to six full digits (Recommended) ±999,999 More digits may be used, but the stability will be affected. Increase the filter value and lower the display update rate to get a more stable reading.
Transmitter Power Supply	Isolated 24 VDC @ 200 mA/input Max current: 1,600 mA (All inputs) (8) Analog Input @ 200 mA max (28) Analog Input @ 20 mA max Available on AC or DC powered units
Temperature Drift	Better than: 20 ppm/°C from -40 to 60°C ambient
Filter	Window: 0.5, 1, 2, 4, 8 sec, IIR: 16, 32 sec Glitch Filter: Discards a single sample caused by high frequency noise
Filter Bypass	0 to 100 % of full scale Filter is ignored, if the signal change is greater than bypass value
Channel Input Scale Function	Linear 2-Point, Multi-Point (up to 50 points) Square Root Programmable Exponent Scale Factor Round Horizontal Tank (Volume) None (mA Input Reading)
Channel Input Live Calibration	Each channel may be calibrated using live calibration signal from a sensor or a calibrator.
Input Protection	Each 4-20 mA input is protected by an auto-resettable fuse, 30 VDC max. The fuse resets automatically after the fault condition is removed.
Input Impedance	125 Ω typical, including auto-resettable fuse
Hart Transparency	The controller does not interfere with existing HART communications; it displays the 4-20 mA primary variable and it allows the HART communications to pass through without interruption. The controller is not affected if a HART communicator is connected to the loop. The controller does not display secondary HART variables.
Isolation	1500 V: Input-to-power line 500 V: Input-to-input, input-to-output All analog inputs and analog outputs are isolated from each other.
Normal Mode Rejection	100 dB at 50/60 Hz
Common Mode Rejection	90 dB at 50/60 Hz

Pulse Inputs

Number Of Inputs	(4) Pulse inputs/card (28) Pulse inputs max, no other I/O
Input Type	Active Square Wave, NPN, PNP, Reed Switch, Coil (Magnetic Pickup) Normal threshold: 1.2 V (0.8 to 3.0 V) High threshold: 2.5 V (2.0 V to 6.0 V) Coil threshold: 20 mV (Low) or 100 mV (High)
Signal Level	Active Square Wave: 0 to 30 V max Typical: 0 to 5 V Coil: 20 mVp-p to 30 Vp-p (Magnetic Pickup)
Input Impedance	Active, NPN, Reed: 10 kΩ pull-up to 5 V PNP: 10 kΩ pull-down to (S-) Coil: >2 kΩ (20 mV sensitivity), >10 kΩ (100 mV sensitivity)
Isolation	Pulse inputs are not isolated, (S-) terminal is connected to system GND
Input Protection	±36 V, non-isolated
Frequency Response & Signal Level	Active Square Wave 5 V: 0 to 100 kHz Coil (Magnetic Pickup): 0 to 50 kHz <u>Frequency – Signal level (Coil: 20 mV)</u> 20 mVp-p – 100 Hz 100 mVp-p – 10 kHz <u>Frequency – Signal level (Coil: 100 mV)</u> 100 mVp-p – 90 Hz 500 mVp-p – 5 kHz 20 Vp-p – 50 kHz
Minimum Frequency	250 μHz with High Gate = 4,000 sec
Low Gate	1 to 99 sec
High Gate	2 to 4,000 sec (Must be higher than low gate)
Accuracy	±1 count for K-Factor > 1 or 30 ppm
K-Factor	Programmable pulses/unit of measure with up to 15 decimal resolution
Scale Pulse Input	Linear 2-Point Multi-Point Scaling: 2 to 50 points
Live Calibration	Pulse input channel may be calibrated using live calibration signal from a sensor.

Modbus Inputs

Number of Inputs	199 Modbus RTU
Scale Mb Input	Modbus input may be used as the input for creating channels and totals, the same way 4-20 mA inputs are used.
Data Type	Bit-Logic Signed/Unsigned: 16 (Short), 32 (Long), 64 (Long-Long) Float 32 Float 64 (Double)
Decimal Point	User selectable
Comm Break & Timeout	Specify what value to hold on comm. break and how long to wait for new data before reporting a break condition.
Input Action	Specify what should happen when new data is written to the input register (e.g. add value to total).

Digital Inputs & Outputs

Digital Inputs	5 Inputs, non-isolated, 30 VDC max Standard feature on all ConsoliDator+ models Low: 0 to 1.2 V High: 2.8 to 30.0 V Internal pull-up: 5 kΩ to 5 V Max pulse frequency: 1 kHz @ 5 Vp-p +5 V terminal: Internal pull-up 100 Ω Note: Pulse inputs may be used as digital inputs
Digital Input Types	Normally open switch: External excitation not required (Current: 1 mA) Open collector: 4.1 V open circuit voltage Logic level: 0 to 30 V
Assignment & Operation	Active Low or Active High Functions: Remote front panel button, total functions, timer control, alarm functions, screen navigation, horn functions, reset relay information. Digital inputs can be used as input source for channels, totals, and alarms.
Digital Outputs	4 Outputs Standard feature on all ConsoliDator+ models Low: 0 V (no load), 1.5 V max @ 10 mA sink (External pull-up) High: 5.0 V (no load), 3.5 V @ 10 mA load Maximum current: 30 mA Output impedance: 100 Ω Output protection: 150 mA auto-resettable fuse Max frequency: 5 Hz
Digital Output Assignment	Digital outputs require logic units as the input Input sources: Digital input, Modbus input, channel, alarm, horn, always on, or always off
Input / Output Protection	±36 V, non-isolated

Relays

Number of Relays	(5) Relays/card (30) Relays max with (4) analog or (4) pulse inputs, no other I/O
Rating	SPDT (Form C) Resistive load: Rated 10 A @ 120/240 VAC or 8 A @ 30 VDC Inductive load: NO contacts: 1/3 HP, 120 VAC; 30,000 cycles NC contacts: 1/8 HP, 120 VAC; 50,000 cycles Minimum load: 100 mA @ 5 VDC
Isolation	1500 VAC, 50/60 Hz for 1 min between coil and contacts
Deadband	0-100% of full scale, user selectable
Electrical Noise Suppression	TVS diodes & snubbers on all contacts. Recommended additional external snubber: 0.01 μF/470 Ω, 250 VAC (Order: PDX6901)
Assignment & Operation	Any relay may be assigned to any alarm, channel, total, timer, digital input, Modbus input, pump alternation, horn, always on, or always off. Multiple relays may be assigned to the same alarm or channel. All relays are programmed independently. High & Low Alarm: Defined by set and reset points in the Alarm menu High or Low Alarm: Assign relay to any alarm or channel for on/off relay control <i>Note: Automatic reset only for channel</i> Multi-Source High or Low Alarm: Assign relay to multi-source alarm to indicate common high or low condition. Pulse Action: Set any relay for pulsing on/off timed relay control. Programmable pulse width (on/off time) and on/off delay. Sampling: Relay must be assigned to channel setup for Sampler function with user-defined total increment and sampling time. Pump Alternation: Any relay may be setup to alternate with any relay in the group. Multiple alternation groups may be setup.
Acknowledge	Front panel Ack key or digital input acknowledges alarms; relays associated with acknowledged alarm are turned off. Acknowledge all or any alarm.
Alarm Relay	Assign any relay to be driven by any alarm; acknowledging the alarm turns off the relay (non-fail-safe mode).
Time Delay	Programmable on/off delays, 0.0 to 999.9 sec Independent for each relay.
Auto Initialization	When power is applied to the controller, relays will reflect the state of the input to the controller.
Fail-Safe Operation	The relay coil is energized when the process variable is within safe limits and the relay coil is de-energized when the alarm condition exists.

4-20 mA Transmitter Outputs

Number of Analog Outputs	(5) Analog outputs/card (35) Analog outputs max with no other I/O cards (Seven I/O slots)
Output Range	4.00 to 20.00 mA, nominal
Calibration	Factory calibrated for 4-20 mA
Scaling Range	Any process range Reverse scaling allowed
Assignment & Operation	Assign to any analog or pulse input, digital input, Modbus input, channel, total, timer, alarm, or fixed value (none). <i>Note: Multiple 4-20 mA outputs can be assigned to the same input.</i>
Accuracy	±0.03% F.S. ±0.005 mA
Temperature Drift	20 ppm/°C from -40 to 60°C ambient. (Output & Input drifts are separate)
Output Loop Power	Powered by controller or externally by 12 to 32 VDC
Output Loop Resistance	Powered by controller: 10 to 600 Ω External 12 VDC: 10 to 200 Ω External 24 VDC: 10 to 600 Ω External 32 VDC: 10 to 1000 Ω
Isolation	1500 V: Output-to-power line 500 V: Output-to-output, output-to-input All analog inputs and analog outputs are isolated from each other.

Timers

Number of Timers	Up to 32
Time Format	hh:mm:ss with 0 decimals selected Seconds with 1 or more decimals
Automatic Actions	Power Up: Timer action on power up Error: Action when an error is detected Reset: Event causes the timer to reset Start: Event triggers the timer to start Stop: Event causes the timer to stop
Start / Stop Reset	The function keys and digital inputs can be used to start, stop, and reset the timers, regardless of the automatic actions selected.
Assignment & Operation	Timers can be triggered, stop, and reset, by rising or falling signals from 4-20 mA input, pulse, digital, Modbus input, channel, total, other timers, alarm, mA output, relay, or Modbus output.
Count Down Timer	Select count down and enter starting time
Timer Alarm	Timer can be used to trigger alarms
Bargraph	Select bargraph during setup and scale the bargraph for 0 – 100% target time
Timer Control	Access timer control via the <i>View Timer</i> menu or assign a function key to timer control in the <i>Screens</i> menu
Timer & Relay	Timer can be assigned to drive relays based on selected set and reset points

Modbus® Serial Communications

Compatibility	RS-485 (EIA-485)
Protocol	Modbus RTU
Device Address	1 to 247
Transmit Delay	0 to 99 ms
Baud Rate	1,200 to 115,200 bps
Data	8 bit (1 start bit, 1 stop bit)
Parity	Even, Odd, None with 1 stop bit, or None with 2 stop bits

Ethernet Communications

Device	Lantronix Xport-05
Protocol	Modbus TCP/IP (Default) Modbus UDP/IP Modbus RTU Over TCP/IP Modbus RTU Over UDP/IP
Port Settings (Do Not Change)	Protocol: RS-232 Baud Rate: 9600 Data Bits: 8 Flow Control: None Parity: None, Stop Bits: 1
Network Stack	IPv4
Ethernet Mac/Phy	10/100 Mbps
Additional Specifications	Refer to the Lantronix Webpage https://www.lantronix.com/products/xport
Ethernet Port Configuration	Download the Lantronix DeviceInstaller software to configure the Ethernet port https://www.lantronix.com/products/xport See page 54 <i>Ethernet Port Setup</i> for instructions.

ConsoliDator+ Software

System Requirements	Windows® 7, 10
Compatibility	One software version for all models
Connection	Micro-USB
Configuration	Configure inputs and outputs, channels, totals, timers, alarms, etc. Configure bargraph and panel colors for normal operation, and colors for alarm indication. Save controller settings file on PC for programming other controllers or to restore settings.

Safety Information

CAUTION

- Read complete instructions prior to installation and operation of the controller.

WARNINGS

- Risk of electric shock.
- Hazardous voltages exist within enclosure.
- Installation and service should be performed only by trained service personnel.

Installation

Unpacking

Remove the instrument from its box. Inspect the packaging and contents for damage. Report any damages to the carrier. If any part is missing or the controller malfunctions, please contact your supplier or the factory for assistance.

Panel Mounting

- Prepare panel cutout per the dimensions provided
- Locate the panel mounting bracket and screws
- Inspect the controller to assure the gasket is securely in place
- Insert controller in the panel cutout, the latches on the top and bottom should hold it in place
- Insert the panel mounting bracket from the back of the panel, observe the orientation of the piece marked TOP
- Install the 12 screws provided

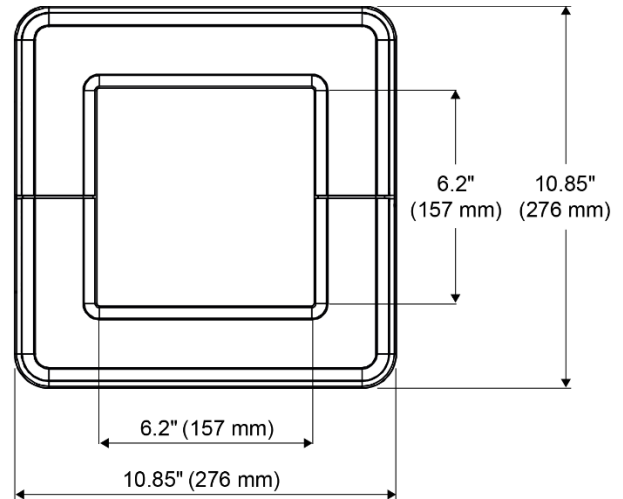

Figure 1. Front Panel Mount Dimensions

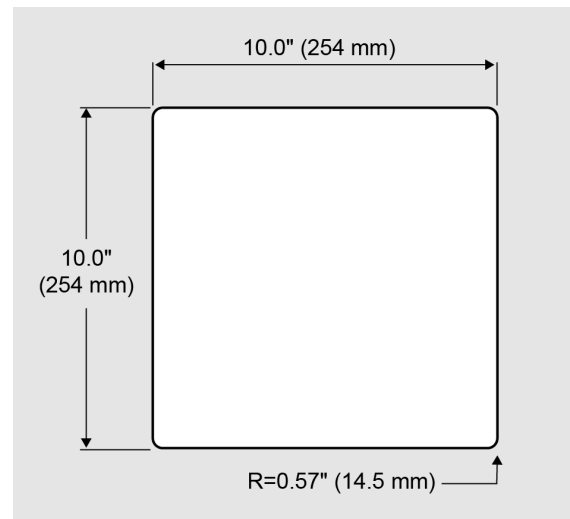

Figure 2. Panel Cutout Dimensions

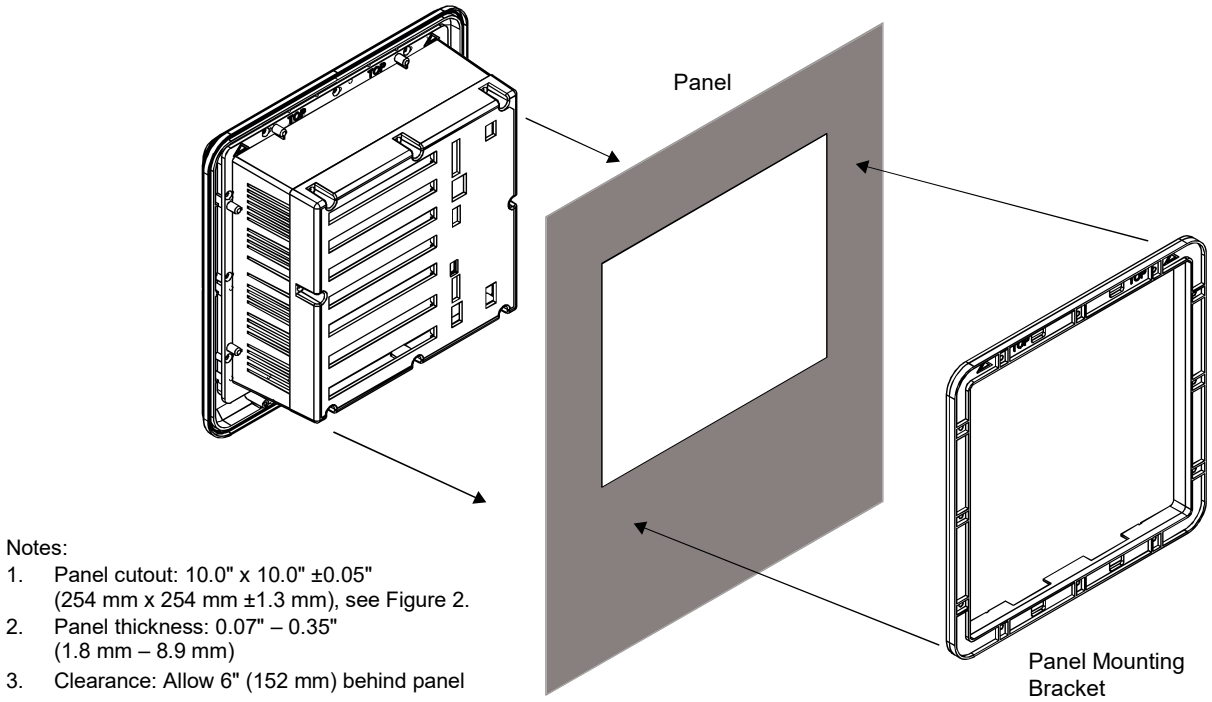

Figure 3. Panel Mount Installation

Mounting Dimensions



Download free 3-D CAD files of these instruments to simplify your drawings!

predig.com/documentation-cad

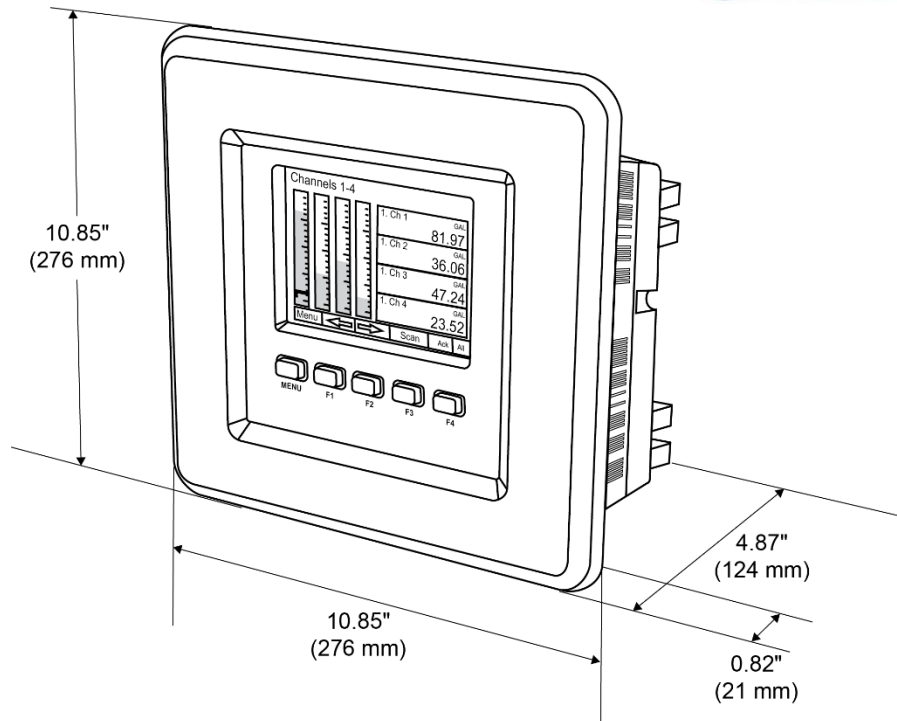
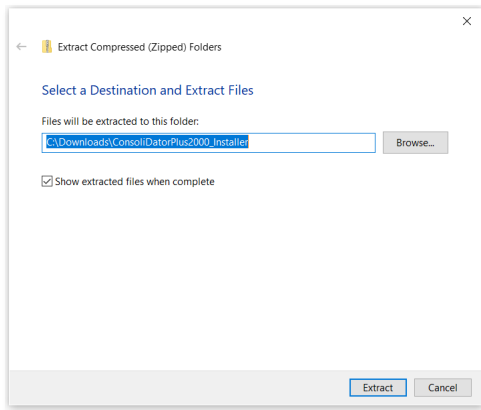
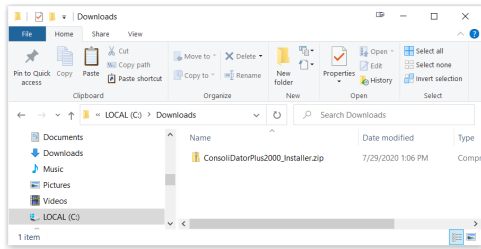

Figure 4. Panel Mount Overall Dimension

ConsoliDator+ Configuration Software Installation

We recommend the following sequence for getting the controller into service:

1. Download the latest version of the ConsoliDator+ configuration software from our website predig.com/software or from the included CD.
2. Extract the contents of the *ConsoliDatorPlus2000_Installer.zip* file into a folder in your computer.



3. Double-click on the executable file *ConsoliDatorPlus2000_Installer.exe* and follow the on-screen instructions.

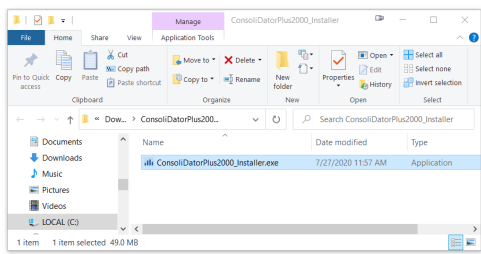

4. Depending on your system, a Windows message might be displayed:

“Do you want to allow this app from an unknown publisher to make changes to your device?”

Click **Yes** and proceed with the installation.

5. Click on *Install* to start the software installation process.

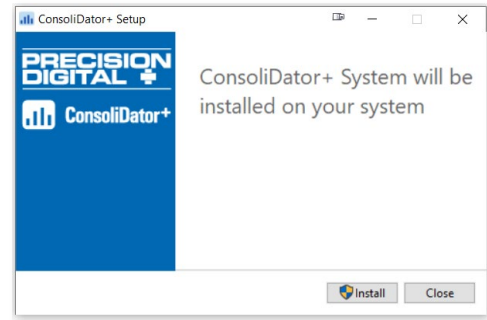

6. If your computer does not have the .NET desktop runtime 3.1, it will be installed automatically.

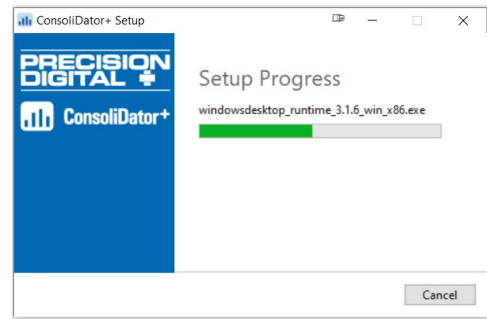

7. If the .NET desktop runtime 3.1 is already installed, it will proceed to the installation of the ConsoliDator+ configuration software.

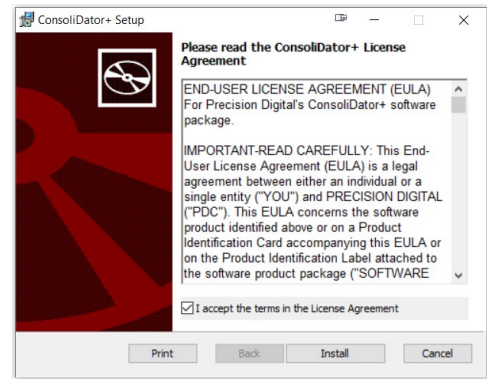

8. Read and accept the software's License Agreement and click on *Install*.

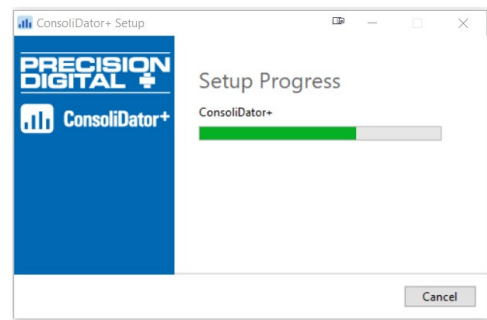

- Click on *Finish*.

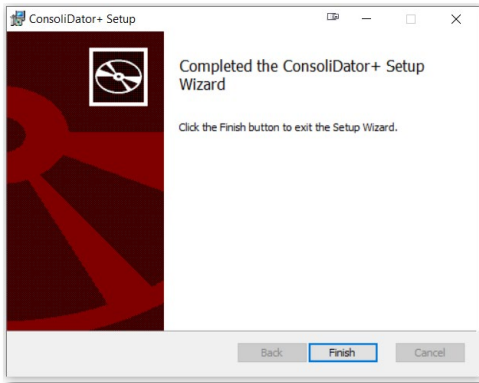

- After the installation is complete, the following message is displayed. Click *Close* to finish. A ConsoliDator+ icon will be placed on your desktop.

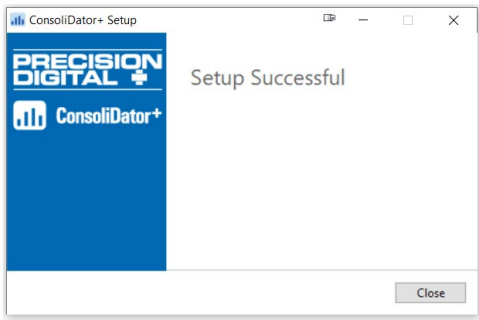

You are now ready to start using the software to configure your ConsoliDator+ controller.

The easiest and quickest way to program your ConsoliDator+ is to use the FREE ConsoliDator+ configuration software available on the included CD or download the latest version from predig.com/software. The ConsoliDator+ configuration software is intuitive, and most customers can get their controller programmed as they like without even looking in the manual.

⚠ WARNINGS

- Only one controller may be connected at a time. Attaching multiple controllers will cause a conflict with the controller software.

ConsoliDator+ Software

- Connect one end of the provided USB cable to the controller and the other end to the computer.

- Double-click on the ConsoliDator icon



- The application will start displaying the System menu

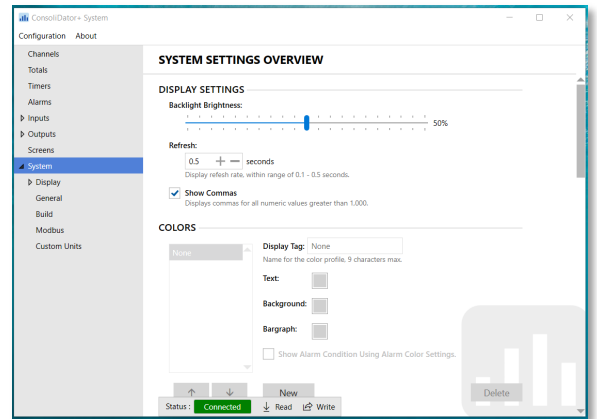

- Click on *Read*, at the bottom of the screen, to read the configuration of the connected controller. After a read the channels settings overview is displayed.

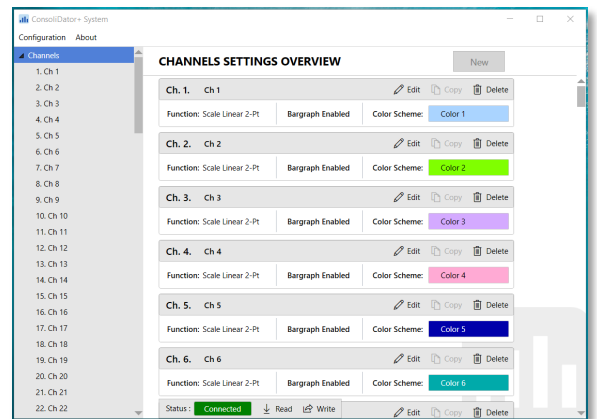

- You can now begin to configure the ConsoliDator+ for your application, either by editing the existing settings or by starting fresh creating a new configuration.

- Click on Configuration to save files, open existing files, or to create a new configuration even without a controller connected.

Connections

The back panel is labeled with the I/O boards that were installed at the factory. The removable connectors are labeled with the connection signal for each terminal. The following diagram shows what the back of the model PD9000-GP-4PI-8AI-10AO-10RY looks like. This model accepts (4) pulse and (8) analog inputs and has (10) 4-20 mA outputs and (10) relays. (5) digital inputs, (4) digital outputs, RS-485 serial capability and USB connections are standard on all ConsoliDator+ models. Ethernet is an option.

If all Input / Output slots are used exclusively for one function, the ConsoliDator+ can accept up to (28) isolated 4-20 mA inputs, (28) pulse inputs, (25) isolated 4-20 mA outputs, and (25) relays. If used as a Modbus slave only: (35) 4-20 mA outputs, (30) relays.

All units can be powered from AC or DC; both power connections can be used at the same time. The DC power supply can serve as backup power if the voltage is 24 V or less, otherwise the controller will run on DC power.

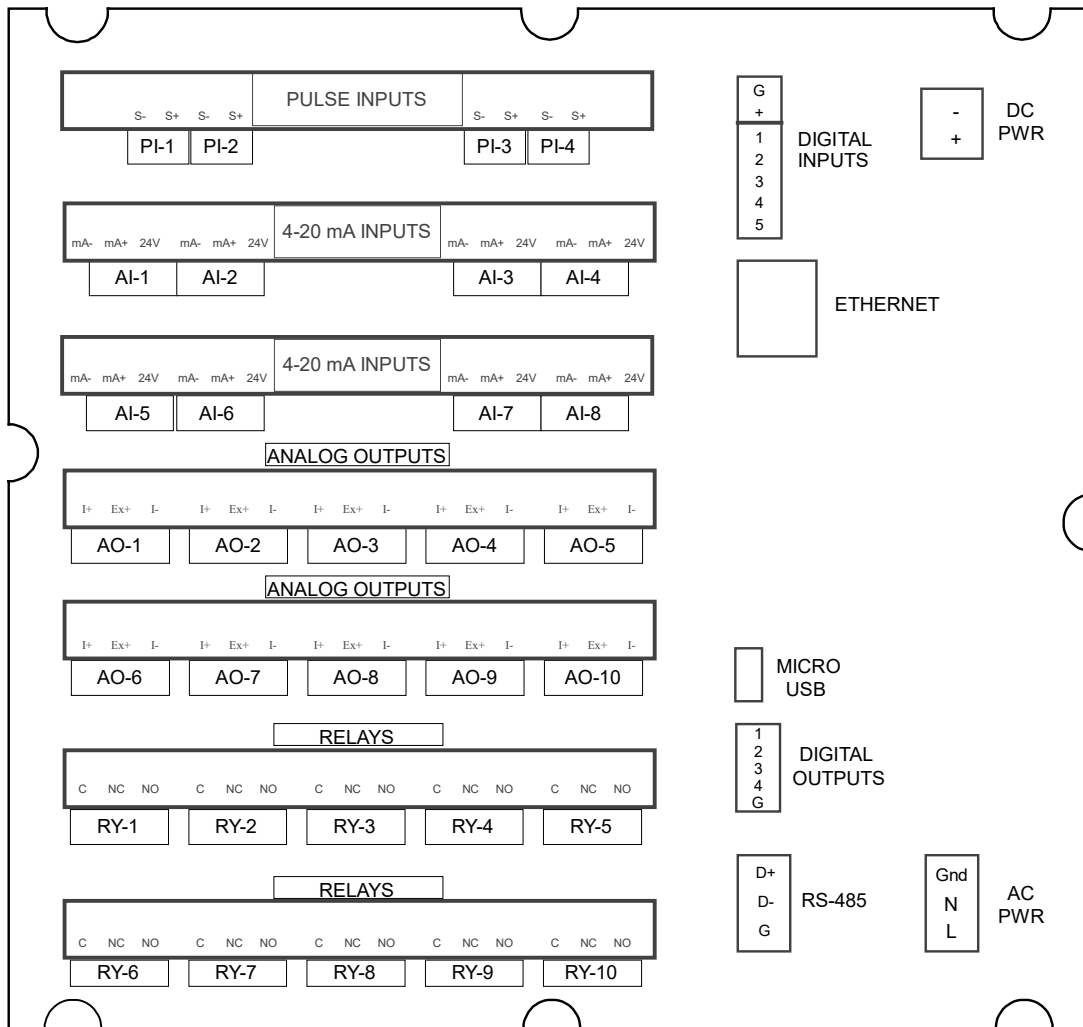

Figure 5. Connection Terminals for a PD9000-GP-4PI-8AI-10AO-10RY

Notes:

1. Each 4-20 mA input has its own isolated 24 VDC power supply to power the transmitter.
2. Each 4-20 mA output has its own isolated 24 VDC power supply to power the output loop.
3. Each relay is Form C and rated at 10 A.
4. Input / output connections are made to removable screw connectors.
5. Every ConsoliDator+ has five digital inputs (additional digital inputs can be obtained by using the Pulse Inputs).
6. Every ConsoliDator+ has four digital outputs.
7. Every ConsoliDator+ has RS-485 with Modbus.
8. All ConsoliDator+ models can be powered from either AC or DC Power.
9. Ethernet with Modbus TCP is an option.
10. Micro USB is used for programming the ConsoliDator+.

CAUTION

- Use copper wire with 60°C or 60/75°C insulation for all line voltage connections. Observe all safety regulations. Electrical wiring should be performed in accordance with all applicable national, state, and local codes to prevent damage to the controller and ensure personnel safety.

Power Connections

Power connections are made to one of the power terminal connectors. All units are capable of being powered either by AC or by DC for the ranges specified.

90-264 VAC Power

- Use three-terminal power connector as shown in Figure 6.
- Unit is protected internally with 1.25 A auto-resettable fuse. 2 A max, slow blow, 250 V min, UL Recognized external fuse recommended.

24 VDC Power ± 10%

- Use two-terminal power connector as shown in Figure 6.
- Unit is protected internally with 3.7 A auto-resettable fuse. 4 A max, slow blow, 50 V min, UL Recognized external fuse recommended.

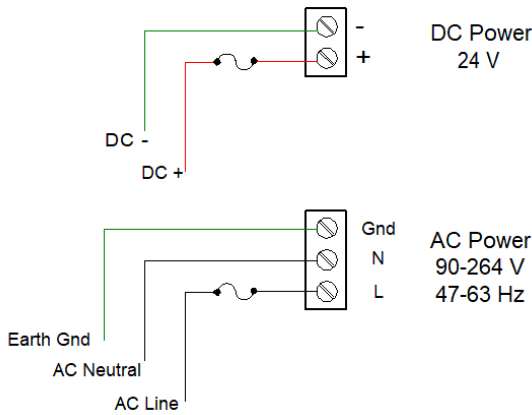

Figure 6. Power Connections

Note:
 The controller may be powered by AC voltage with the DC power connection used as backup power. The DC power supply must be 24 V or less to work as backup; otherwise the controller runs on DC power.

Isolated Input Signal Connections

Isolated input signal connections are made to removable screw terminal connectors, which are labeled individually on the back panel of the controller. The back panel shows the type of input card installed in each slot (The top slot is #1 and the bottom is #7). Individual inputs are referenced as PI-1 to PI-4 for pulse inputs and AI-1 to AI-4, AI-5 to AI-8, etc for analog inputs.

4-20 mA Analog Input Connections

Analog 4-20 Input connections are made to screw terminal connectors (two inputs per connector). The following figures show examples for typical applications. Each of the 4-20 mA inputs may be connected in any of the modes shown below.

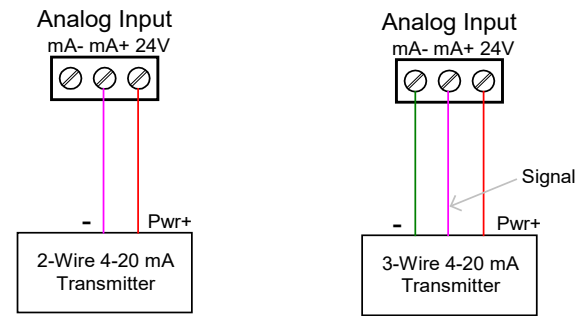

Figure 7. Transmitters Powered by ConsoliDator+ Isolated 24 VDC Power Supply

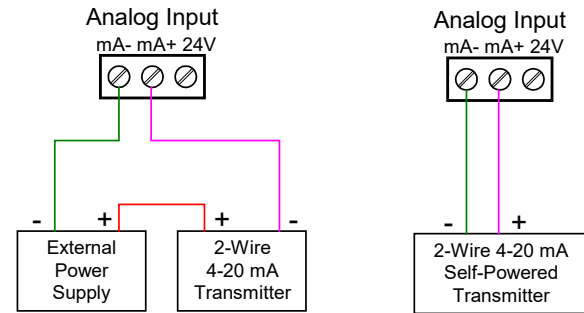

Figure 8. Transmitter Powered by Ext. Supply or Self-Powered

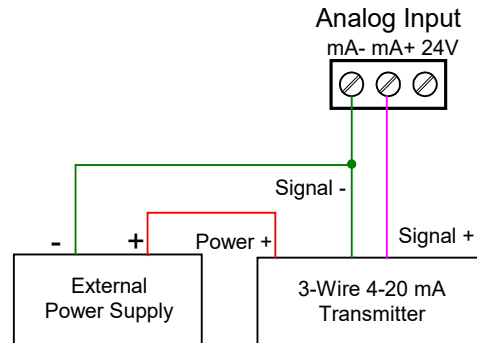

Figure 9. 3-Wire Transmitters Powered Externally

Flow Meter Pulse Input Connections

Flow Meter Pulse Inputs are wired to four-terminal connectors (two inputs per connector). A square waveform is used in the illustration, but the input is capable of reading many other types of signals within the voltage and frequency ranges specified.

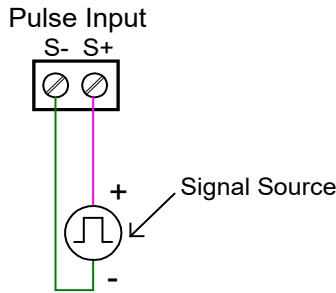

Figure 10. Flow Meter Pulse Input Connections

Digital Input Connections

Inputs are wired between terminals 1-5 of the digital input connector and the G terminal of the 2-position connector above the digital inputs. Normally open switch contacts may be used as shown in Figure 11. The diagram also shows a Digital Input using an NPN open collector transistor output from a live signal. Logic LO or switch closure appearing across the terminals is interpreted as ON. When using an open collector transistor, a logic HI at the base (marked "B" in Figure 11) will be interpreted as ON. The 2-position connector has a +5 V terminal that may be used to provide excitation to some sensors requiring more than the pull-up provided on each digital input terminal.

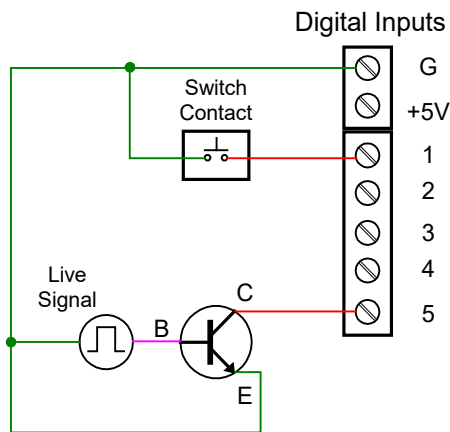

Figure 11. Digital Input from Switch Closure and Live Signal

Analog Output Connections

The following figures show examples for isolated 4-20 mA transmitter output connections. Terminal connectors are labeled individually. The analog outputs are isolated from each other and from the inputs. They are powered internally to provide an active 4-20 mA output loop. The outputs may be powered externally by connecting the positive voltage to the Ex+ terminal.

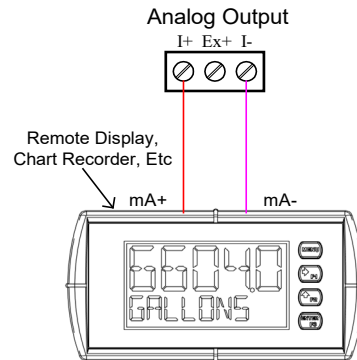

Figure 12. Active 4-20 mA Output Powered by Controller

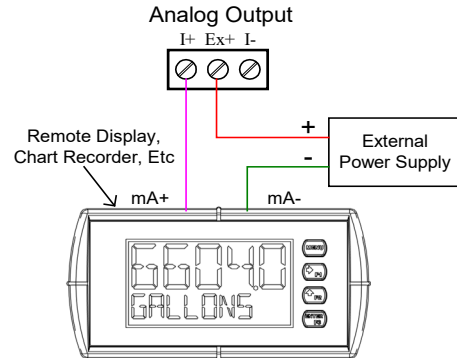

Figure 13. Passive 4-20 mA Output Powered by External Supply

Note: Analog inputs and outputs are isolated from each other

Digital Output Connections

The digital outputs may be used to drive digital inputs, alarm annunciators, or other devices such as solid-state relays that can be driven with low voltage signals.

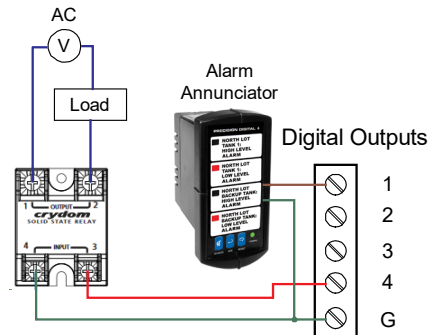

Figure 14. Digital Outputs Driving 5 V Solid State Relay

Connections to Power Gas Detector

Some sensors requiring more than 200 mA of excitation current can be powered by the ConsoliDator+ by connecting two or more power supplies in parallel as shown in the following diagrams.

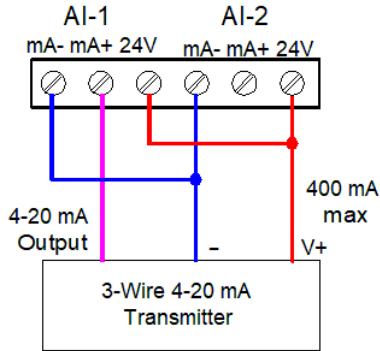

Figure 15. Two Supplies in Parallel Powering 3-Wire Transmitter

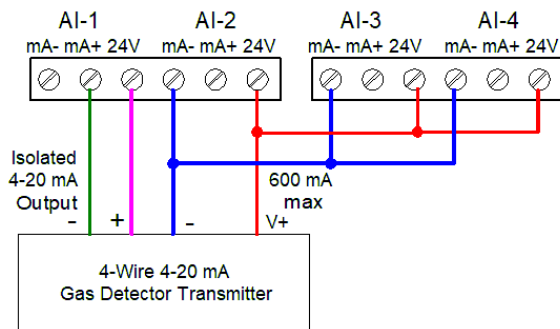

Figure 16. Powering 4-Wire Gas Detector & Isolated 4-20 mA Output

Relay Connections

Relay connections are made to three-terminal connectors labeled individually. There are five relays per card.

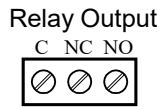

Figure 17. Relay Connections

Switching Inductive Loads

The ConsoliDator+ has internal circuitry to protect the relays from inductive loads, however, the use of external suppressors (snubbers) is strongly recommended when switching inductive loads to prevent disrupting the microprocessor's operation. The suppressors also prolong the life of the relay contacts. Suppression can be obtained with resistor-capacitor (RC) networks assembled by the user or purchased as complete assemblies. Refer to the following circuits for RC network assembly and installation.

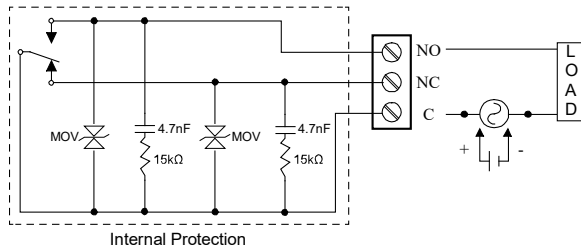

Figure 18. AC and DC Internal Inductive Loads Protection

For additional external protection choose R and C as follows:

- R: 0.5 to 1 Ω for each volt across the contacts
- C: 0.5 to 1 μF for each amp through closed contacts

Notes:

1. Use capacitors rated for 250 VAC.
2. RC networks may affect load release time of solenoid loads. Check to confirm proper operation.
3. Install the RC network at the instrument's relay screw terminals. An RC network may also be installed across the load. Experiment for best results.

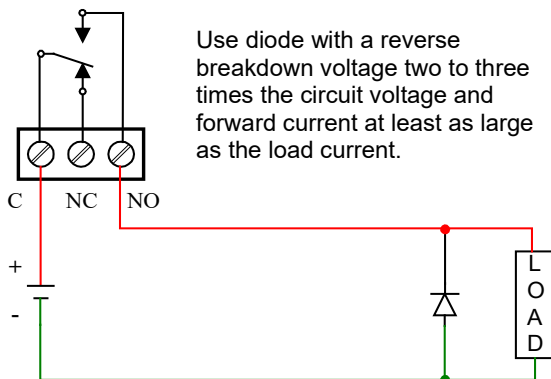

Figure 19. Low Voltage DC Loads Protection

RC Networks Available from Precision Digital

RC networks are available from Precision Digital and should be applied to each relay contact switching an inductive load. Part number: PDX6901.

Serial Communication Connections

The RS-485 port for serial communication (using Modbus protocol) has three terminals labeled D+, D-, and G. It is strongly recommended to use three-wire shielded cable and to always connect the ground terminal to the other equipment's ground to avoid differential voltage between the systems. Distances up to 4000 feet can be reached with RS-485. Up to 32 Modbus devices may be connected to a single RS-485 bus.

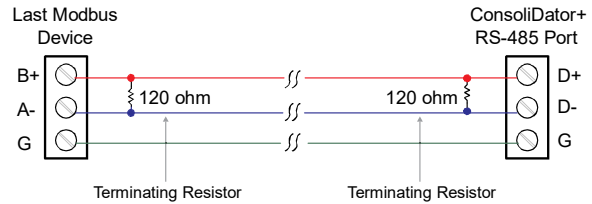

Figure 20. Serial Connections

Ethernet Option

The Ethernet port is available on the RJ45 connector. This allows the ConsoliDator+ to connect to a local area network. The Ethernet port option is fully configured using the Lantronix DeviceInstaller software, available for download from the Lantronix's Website at www.lantronix.com/products/xport. See page 15 for specifications, page 53 for setup using the ConsoliDator+ software, and page 54 for complete Ethernet Port Setup.

External Keypad Connections

Normally open pushbuttons may be wired to the digital inputs connector for use when the front panel of the controller is not accessible. The external keys may be assigned to replicate the Menu and F1-F4 function keys.

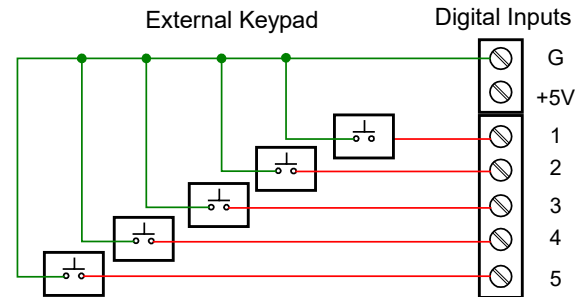

Figure 21. External Keypad Connections

Navigating and Editing

The device displays various screens throughout programming and operation. Functions are programmed within their respective menu screens and in many cases are accompanied by user prompts.

Soft-Keys and Buttons

The unit is equipped with five buttons located below the display. The function of each button corresponds to its soft-key, which appears at the bottom of the screen. Buttons assume different functions, which change according to the screen in view.

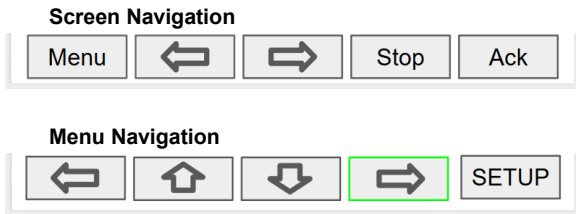

Selections are highlighted with green background for illustration purposes. The keys below are used to navigate through menus and edit settings. Other special keys appear throughout the programming process.

Note:

This is not a touch-screen display; the pushbuttons must be used to activate the soft-key

Key	Action
Menu	Enter menu
Right-key →	Step into menu/setting
Left-key ←	Exit/go back
Down-key ↓	Next screen/channel/setting
Up-key ↑	Previous screen/channel/setting
Stop	Stop automatic scan
Scan	Scan screens automatically
Ack	Acknowledge alarms/relays
Reset	Reset total/max/min
Setup	Enter the Setup menu
Edit	Modify selection
Enter	Execute keypad entry
Ok	Accept setting change
Save	Save all settings in view
Cancel	Discard changes
Delete	Delete channel/item
New	Create new channel/alarm
←	Move cursor left
→	Move cursor right
X→	Delete to the right
←X	Delete to the left
≡	Access additional settings or actions
Alert!	View alarm alerts, manually controlled outputs, and simulated parameters

Setup and Programming

There is **no need to recalibrate** the instrument when first received from the factory. The device is **factory calibrated** prior to shipment, for all input types and 4-20 mA outputs. The calibration equipment is certified to NIST standards.

Overview

Setup and programming are done through the front panel buttons or with the ConsoliDator+ Software. After power and signal connections have been completed and verified, apply power to the instrument.

Inputs, outputs, channels, and relays are configured individually. It is recommended that all inputs be configured before channels, outputs, and relays are programmed.

Shown below are typical screens for tank level applications. Actual screens will vary according to the selected configuration. Screens may be edited, deleted, or added to fit the application.

For information on soft-keys and button functions, see Soft-Keys and Buttons on page 25.

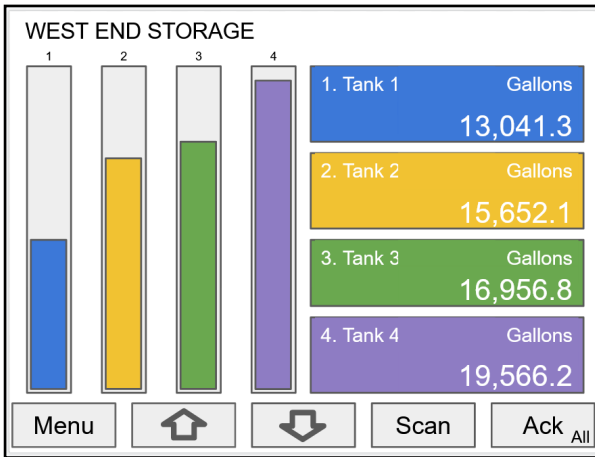

Typical screen view displaying 4 channels and 4 bargraphs representing the values of each channel.

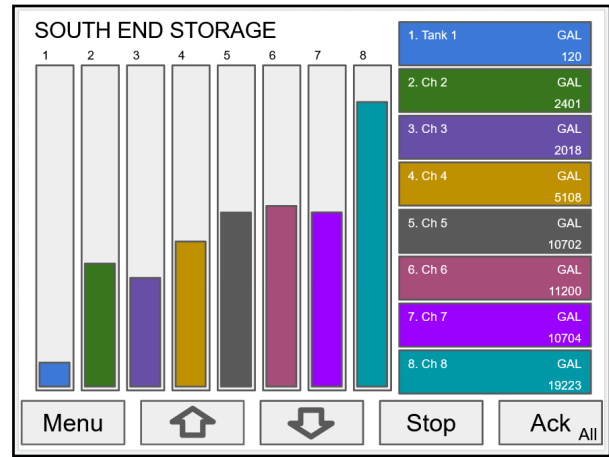

Typical screen view displaying 8 channels and 8 bargraphs representing the values of each channel.

Press the **Menu** key to begin setup and programming

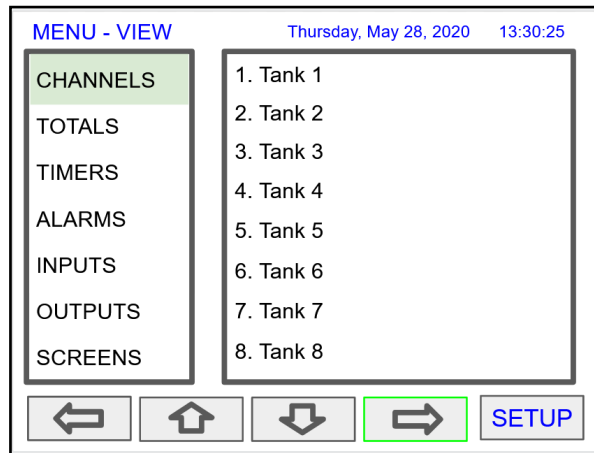

The View screen allows a user to view all the settings and values for Channels, Totals, Timers, etc. To program the instrument, press the **Setup** key.

Setup Menu

The *Setup* menu is the starting point during the programming process for setting up *Channels*, *Totals*, *Timers*, *Alarms*, *Inputs*, *Outputs*, *Screens*, and *System* settings. The number of channels shown on this screen is determined by the number of channels previously configured. More channels may be added to the list, by selecting *New* in the *Setup Channels* menu.

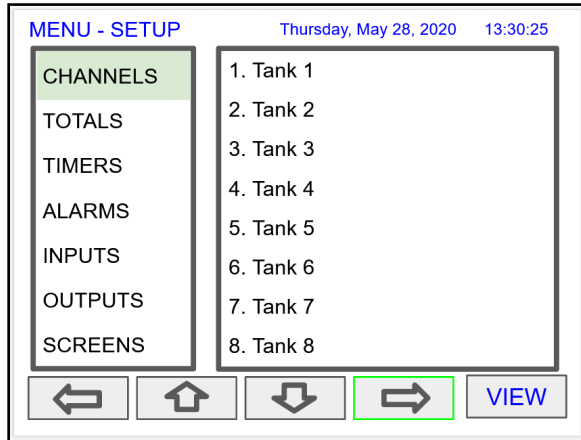

Press **Right Arrow** key to step into channels.

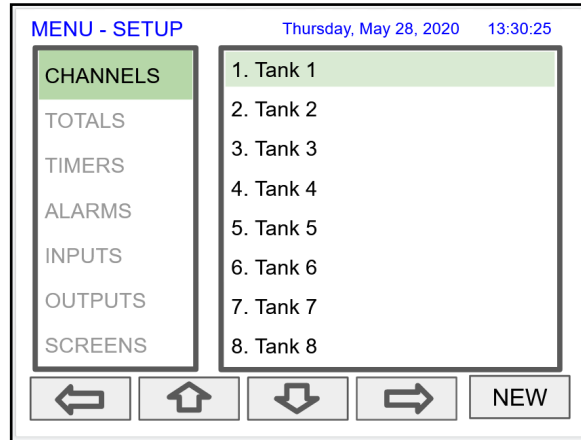

Press **New** key to create a new channel.
Go to page 31 for details.

Channel Parameters

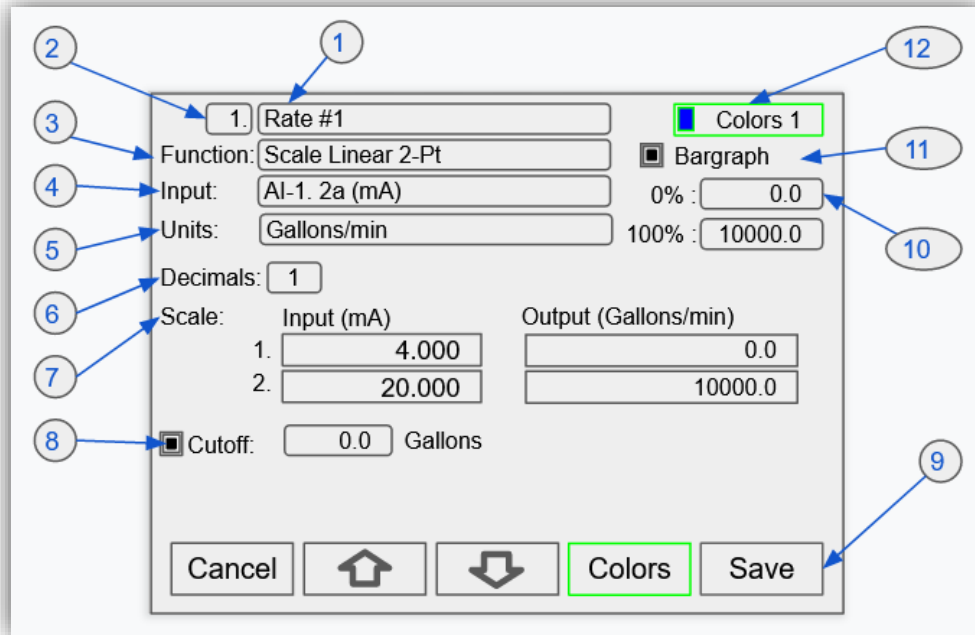

- | | | | |
|---|---|--|--|
| <ol style="list-style-type: none"> 1. Channel tag: Editable 2. Auto-generated channel #: Use to re-order channels 3. Function*: This is the function applied to the input source <ul style="list-style-type: none"> ➤ Scale <ul style="list-style-type: none"> • Scale Factor • Scale Linear 2-Pt • Scale Multi-Point • Scale Square Root • Scale Exponent • Round Horz Tank* • Units Conversion** ➤ Math <ul style="list-style-type: none"> • Constant • Summation • Difference • Absolute Difference • Absolute Value • Average • Weighted Average • Multiply • Divide • % Efficiency | <ol style="list-style-type: none"> ➤ Compare <ul style="list-style-type: none"> • Greatest • Least ➤ Measure <ul style="list-style-type: none"> • Tare • Maximum • Minimum • Percent (Bargraph) • Duration • Rate of Change ➤ Filter <ul style="list-style-type: none"> • Window Average • IIR (First Order) • Cutoff • Limits ➤ Control <ul style="list-style-type: none"> • Sampler • On-Off Control • Select A or B • Schedule ➤ Relays <ul style="list-style-type: none"> • Cycle Count • Runtime ➤ Modbus <ul style="list-style-type: none"> • Time Since Read • Time Since Write ➤ Other <ul style="list-style-type: none"> • None (Reserved) | <ol style="list-style-type: none"> 4. Input: Source for the channel (PV) <ul style="list-style-type: none"> • mA Input (4-20 mA) • Pulse Input • Digital Input • Modbus Input • Channel • Total • Timer • Alarm • mA Output • Relay Output • Digital Output • Modbus Output 5. Units: Engineering units / time or none <ul style="list-style-type: none"> • None • Time • Distance (Height) • Volume • Pressure • Weight • Temperature • Percent • Amps • Volts • Counts • Logic • Custom | <ol style="list-style-type: none"> 6. Decimals: Number of decimals for the PV 7. Input scale: Enter input and output values 8. Cutoff: PV goes to zero below the cutoff value 9. Soft keys: These change based on the screen in place 10. Bargraph scale: Set the 0 and 100% values 11. Display bargraph: Display on the screen 12. Colors: Select the bargraph & panel colors |
|---|---|--|--|

*Round Horz Tank: Available only if Input units is distance (height)

**Use for custom units

See Channel & Math Functions on page 12 for details.

Note: Units conversion is available for all units.

Data Entry Keypad

The system provides a soft keypad for entering values and tags; it contains numbers, alpha characters, and symbols.

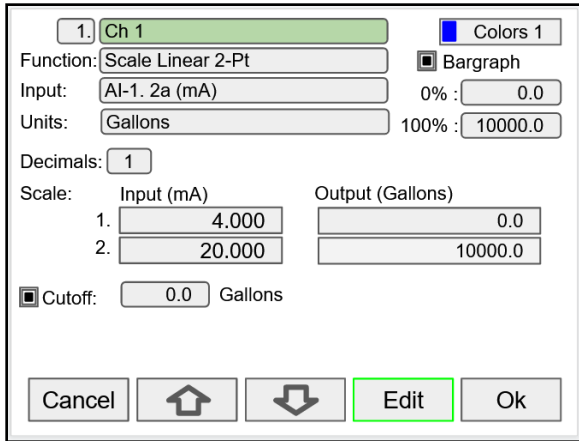

Press **Edit** key to start editing the channel configuration. The green background indicates the field to be edited. Press **Edit** key again to change the channel's tag, this opens the data entry keypad.

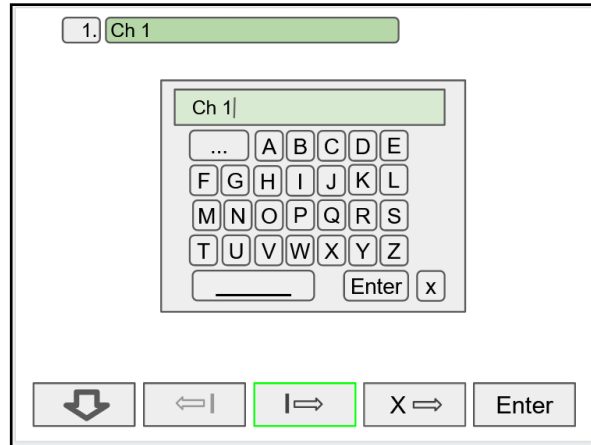

Use the Down Arrow key to navigate to the keypad. Use the **|>** and **<|** keys to move the cursor and use the **X** key to delete characters. To enter characters in the selected text field, use the **arrow** keys to navigate through the popup keypad.

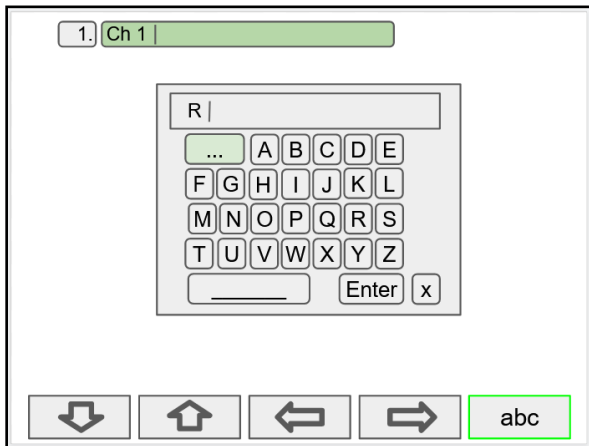

To change the character set, navigate to the **three dots** and press the key indicating the next set of characters.

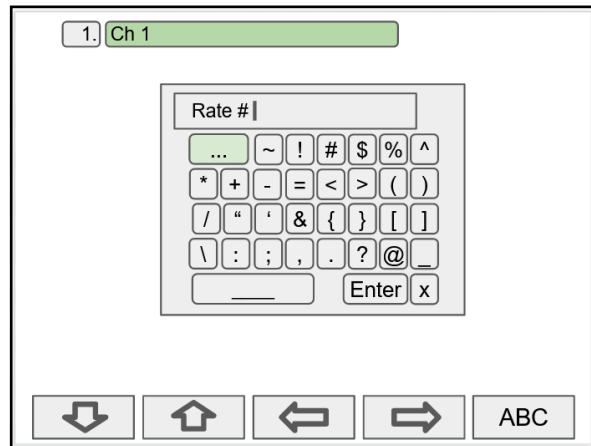

To enter symbols, press the **three dots** and select the desired symbol.

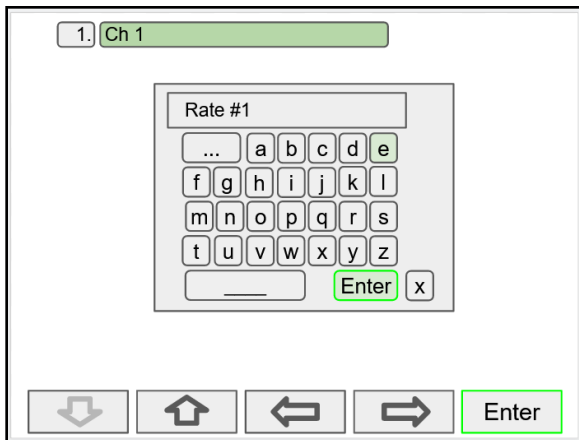

When done typing the characters in the selected field, press the **Enter** key.

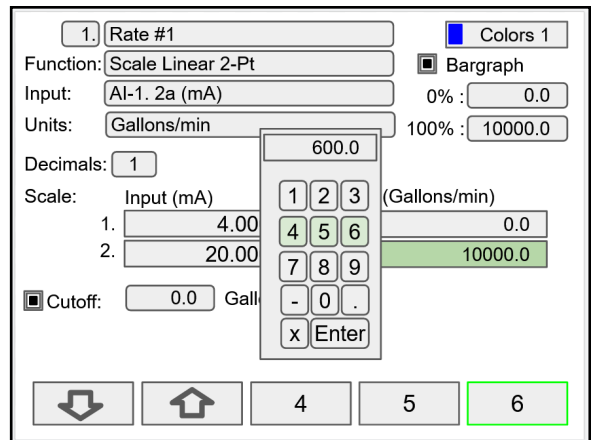

To enter numbers, select the numeric keypad, move the cursor to the insertion point and enter the number using the soft keys.

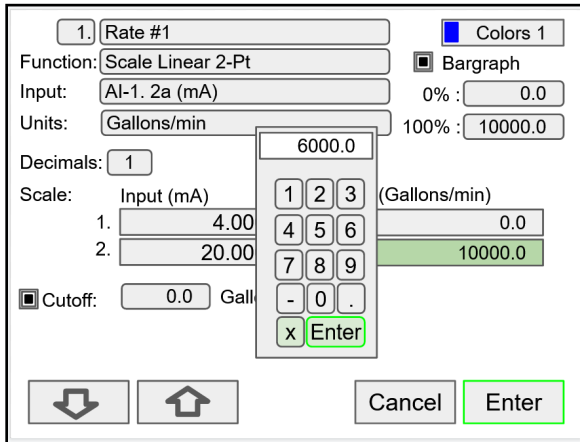

Press **Enter** to accept the changes.

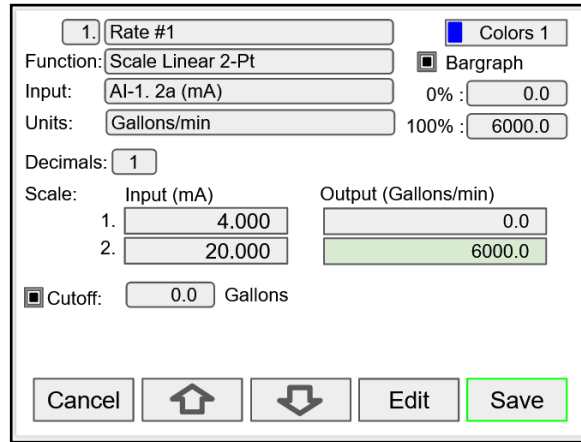

Press the **Save** key to save the changes. The bargraph is automatically adjusted to reflect the scale entered. The bargraph scaling may be changed without affecting the input scaling.

Setup Channels

The *Setup Channels* menu is used to configure each channel, enter a tag, select the input source, scale the input, and program other settings that will determine the channel's processing capabilities.

- Use the **Arrow** keys to navigate through the existing channels
- Press the **New** key to create a new channel
- Press the **Right Arrow** key to step into the channel setup
- Press the **Edit** key to make changes to a particular channel
- Press the **Delete** key to delete a channel

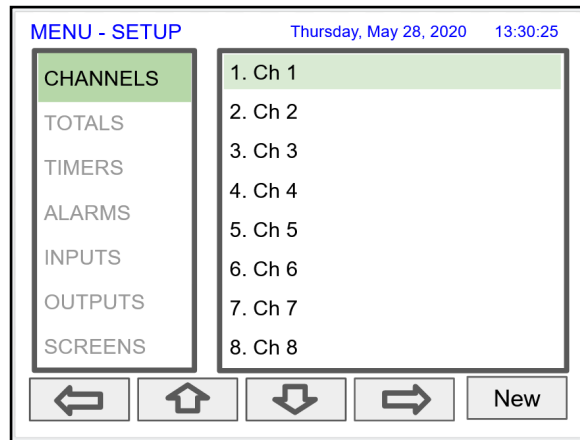

Create New Channel

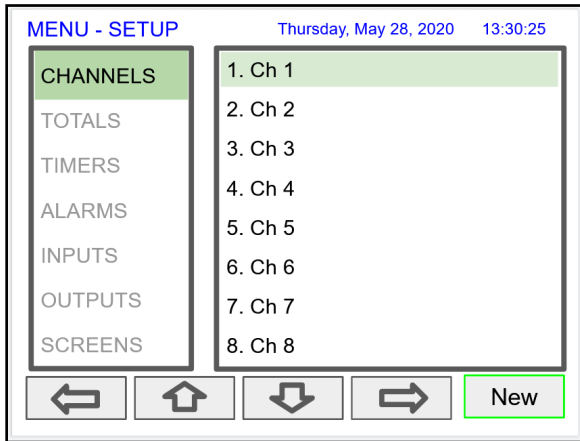

To create a new channel press the **New** key.

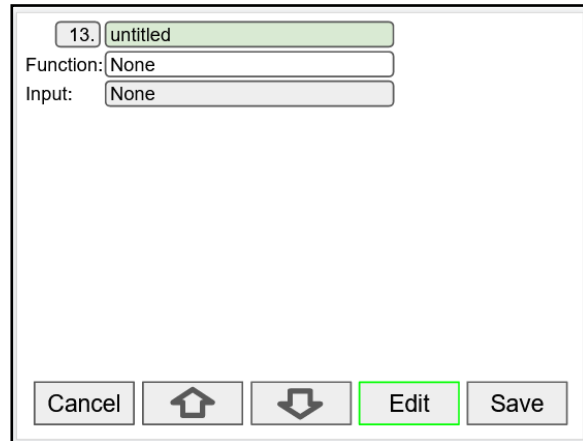

Press the **Edit** key to edit the channel tag and other settings. Press the **Up** and **Down** arrow keys to select setting to be edited.

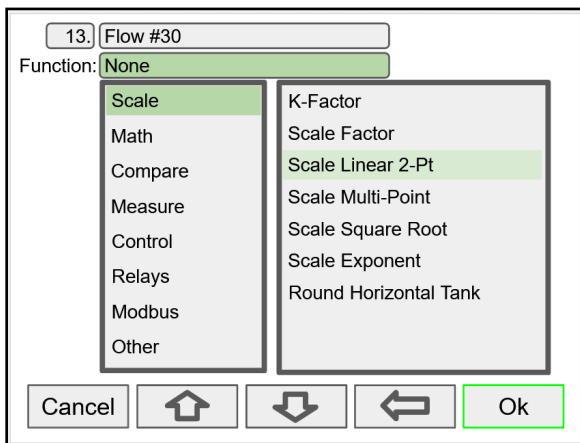

Select the function to be applied to the input and press the **Ok** key.

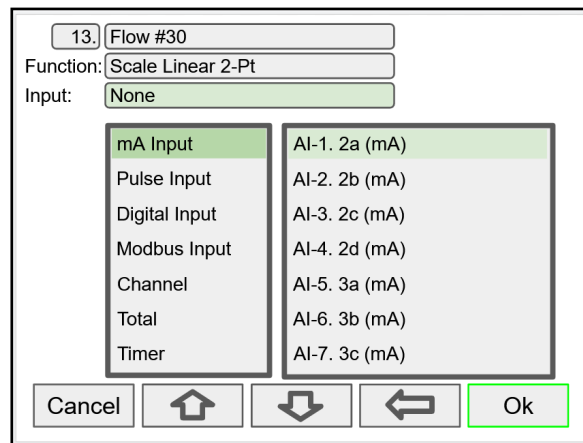

Select the input source for the channel.

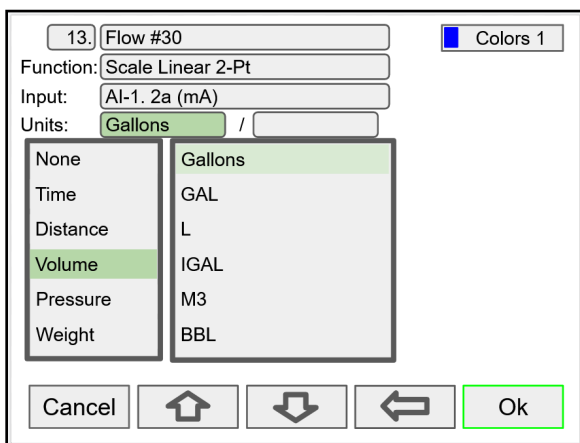

Select the engineering units, decimal point, enter scale points and press the **Ok** key.

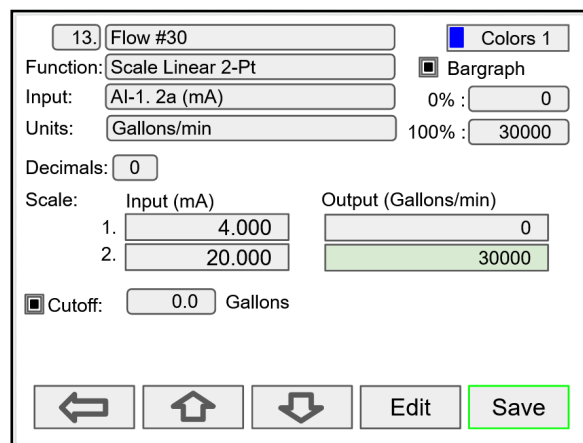

Select number of decimals, scale the input, enter the cutoff value, select colors for bargraph and text, confirm the bargraph's scale, and press **Save**.

Bargraph, Background & Text Colors

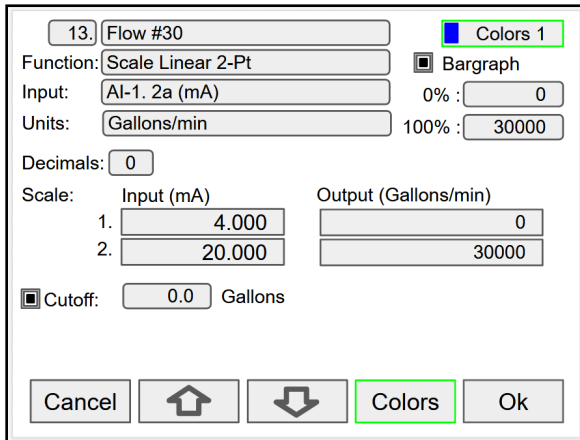

To select a channel color pattern, navigate to the Colors setting and press the **Colors** key.

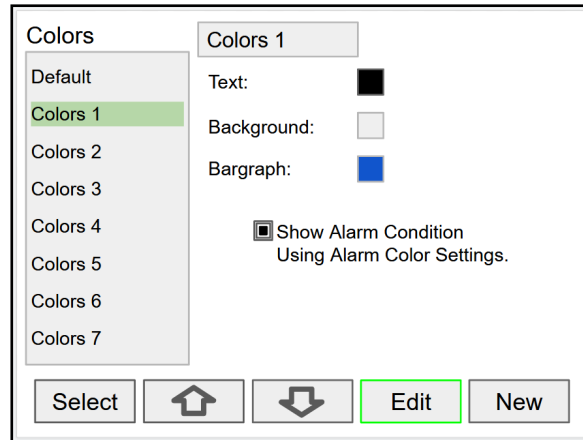

Select a color pattern or press the **Edit** key to make changes to the colors' tag, text, background, and bargraph.

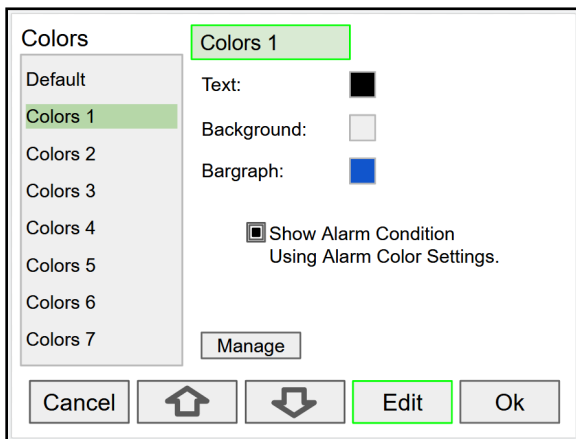

Use the arrow keys to navigate the settings and press **Edit** to make changes.

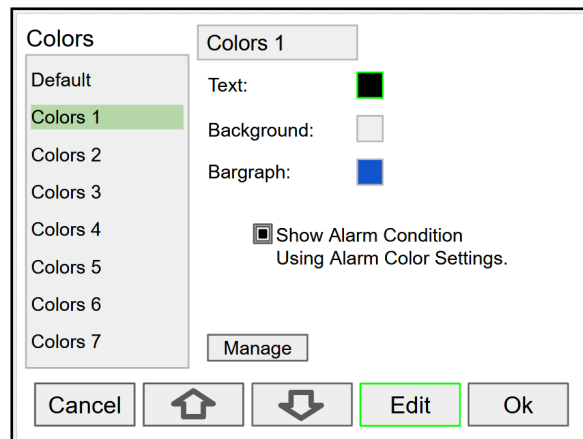

Press **Edit** to change text color, this applies to the channel tag, units, and value.

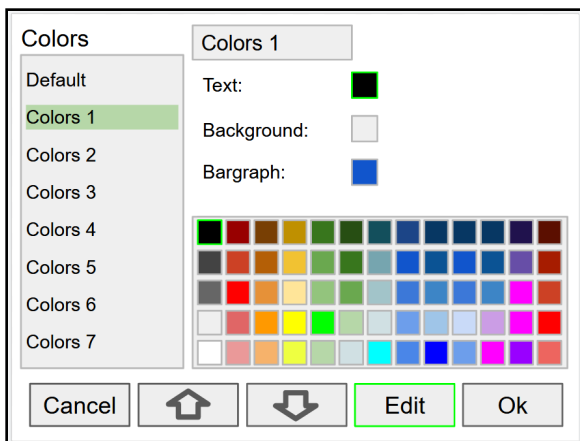

Select the desired color and press **Ok**. Navigate to the other settings and make the necessary changes.

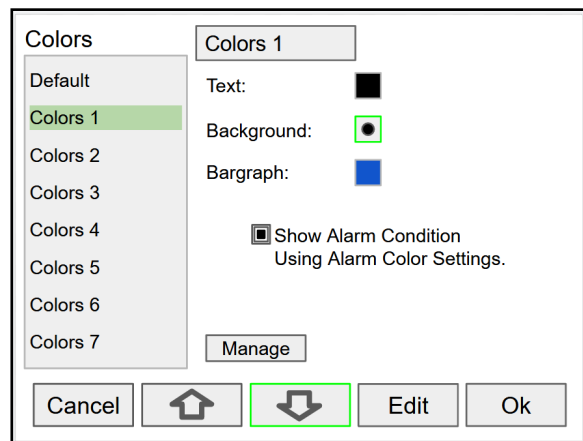

Press **Save** to save the color changes. Press **Select** to apply the color pattern to the channel. The **Manage** button is used to move or delete colors.

Live Calibration

The *Live Calibration* feature is used to calibrate a channel by applying a live calibration signal.

1. From the Setup menu, navigate to the channel to be calibrated.
2. Go to Input 1 entry box
3. Apply Input 1 signal from sensor or calibrator
4. Press & hold the Edit key and press the Live key a few time until a stable reading is displayed.
5. Release the Edit key; the input 1 value has been captured.
6. Repeat the steps above for the additional inputs to be calibrated.
7. Adjust the output values according to the calibrated inputs.
8. Press Save.

Edit Channel

To edit a channel press the **Edit** key and navigate to the setting you want to change, press **Edit** again and make the changes required.

After making all the changes, press the **Save** key.

Delete Channel

To delete a channel, press the **Delete** key and follow the instructions.

Press the **Ok** key to delete the channel or the **Cancel** key to cancel delete action.

2-Point Linear Scaling

Linear mode refers to basic 2-point scaling of a 4-20 mA signal in engineering units. The graph in Figure 22 shows the display response based on example scaling parameters. For this mode select [Scale Linear 2-Pt] from *Function* options, then enter your scaling parameters.

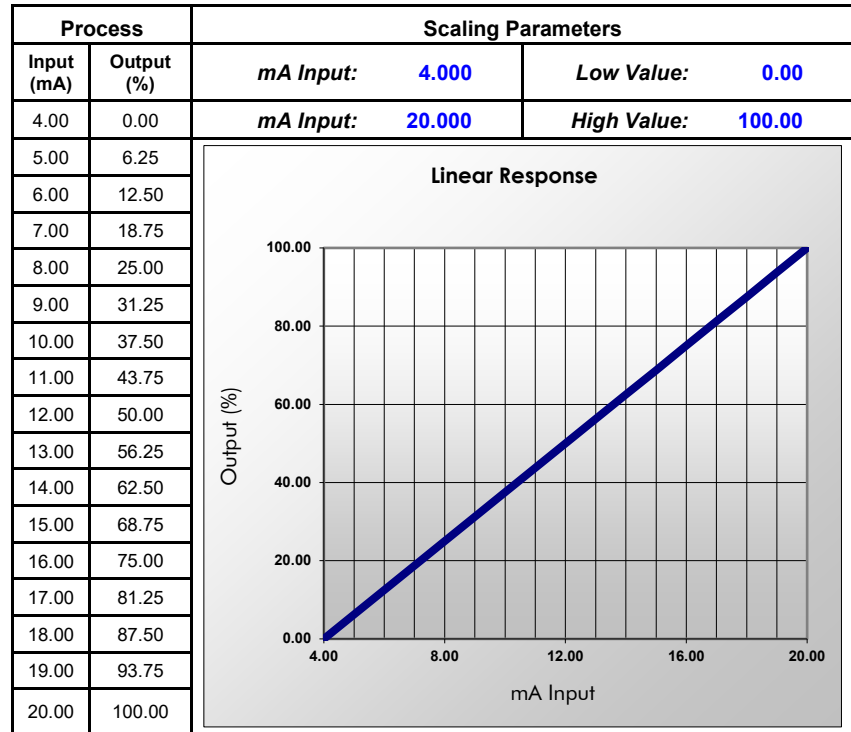

Figure 22. Linear Response Graph

Square Root Scaling

Square root mode refers to 2-point scaling with square root extraction typically used to linearize the signal from a differential pressure transmitter and display the flow rate in engineering units. The graph in Figure 23 shows the display response based on example scaling parameters. For this mode select [Scale Square Root] from *Function* options.

The square root mode supports low-flow cutoff which can be used to suppress readings below a programmed value. Below the cutoff value, the controller will display "0".

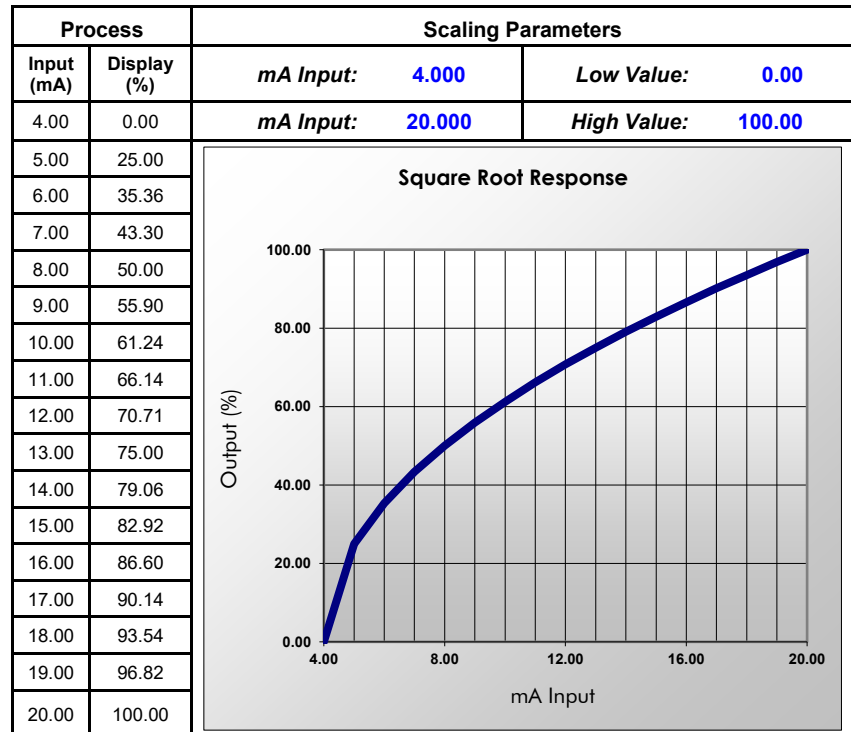

Figure 23. Square Root Response Graph

Scale Exponent

Exponent mode refers to 2-point scaling with programmable exponent, typically used in open-channel flow applications using weirs and flumes to linearize the signal from a level transmitter and display the flow rate in engineering units. The graph in Figure 24 shows the display response based on example parameters and exponent of "1.5". For this mode select [Scale Exponent] from *Function* options. The exponent mode supports low-flow cutoff which can be used to suppress readings below a programmed value. Below the cutoff value, the controller will display "0".

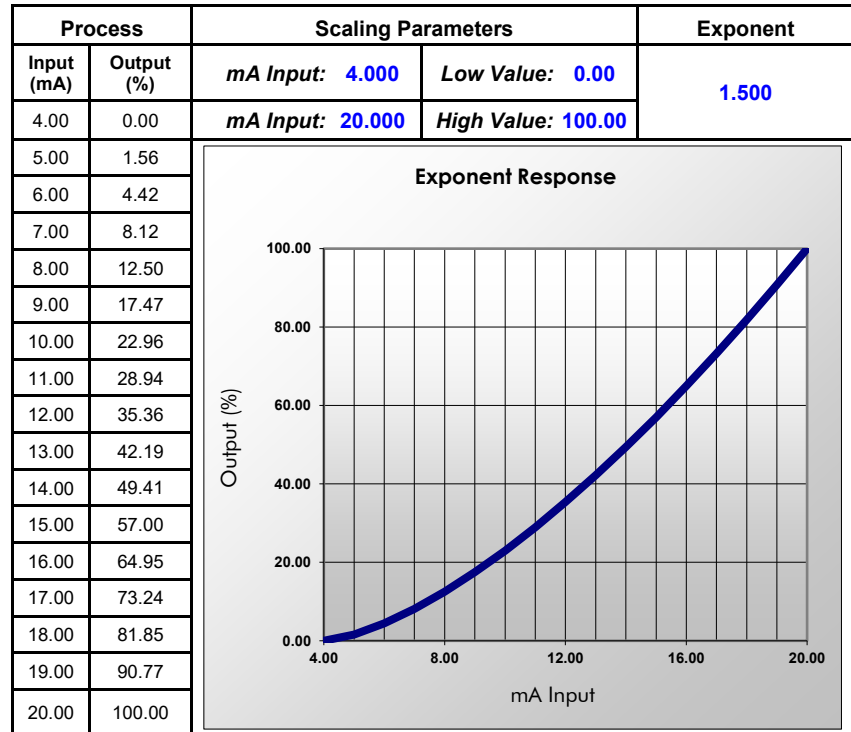

Figure 24. Exponent Response Graph

Round Horizontal Tank

The *Round Horizontal Tank* (RHT) function calculates the volume of round tank with flat ends, based on the diameter and length dimensions of the tank.

The input source for the channel calculating the volume must be a level channel with units of distance (height). The RHT function linearizes the signal from a level transmitter and displays the volume in engineering units. The graph in Figure 25 shows the display response based on tank example:

Diameter = 48.00 inches
 Length = 120.00 inches
 For this mode select [*Round Horz Tank*] from *Function* options.

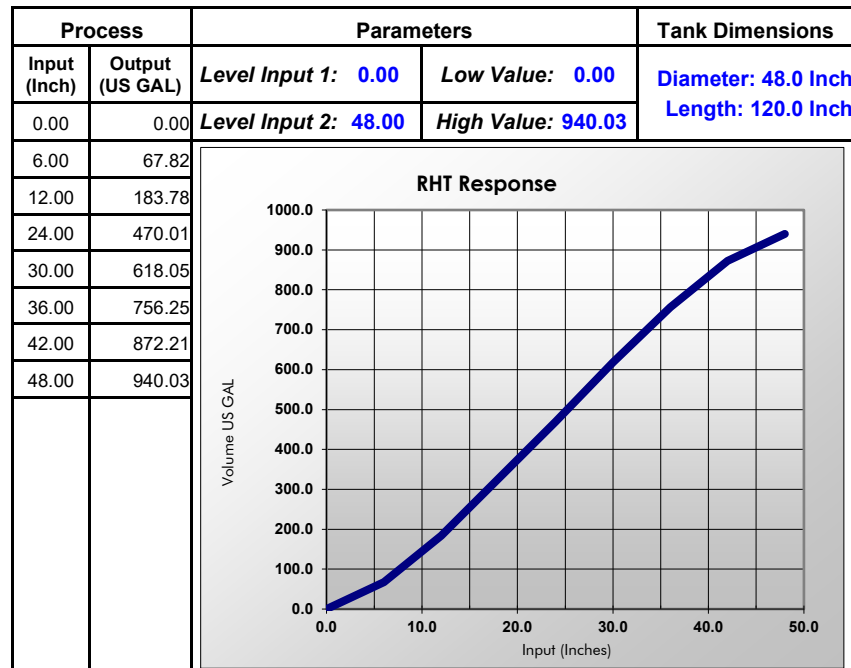

Figure 25. Round Horizontal Tank Volume Graph

Open Channel Flow Application

The PD9000, in combination with an ultrasonic level transmitter, makes for a practical way to measure and display open channel flow rate and total in most weirs and flumes and take periodic samples. All the user needs to do is enter the exponent for the weir or flume into the PD9000 and the PD9000 automatically raises the input signal to that power. Sampling can be based on the total flow or the flow rate. For instance, to display open channel flow rate and total from a 3-inch Parshall flume and take a one pint sample every 100,000 gallons, the user would program the PD9000 as shown in the table above right.

Function	Desire	Programming
Open Channel Flow	3" Parshall flume	Set Programmable Exponent to 1.547
Flow Rate 1	Millions of Gallons per Day (MGD)	Set 4 mA: 0 Set 20 mA: 3.508 Create custom unit: MG Time base: day
Total 1	Millions of Gallons	Input: Flow Rate 1 Select unit = MG
Sampling Channel 2	Take a 1 pint sample every 100,000 gallons	Input: Total 1 Function: Sampler Sample Interval: 0.1 MG Sample Time: 10 sec
Sampling Relay 1	Turn valve on to take a sample	Input: Channel 2 (On / Off) Use a timer to count the time needed to take the sample
Total 2 Non-Resettable	Program controller so total 2 can never be reset	Input: Flow Rate 1 Set total 2 as non-resettable total
Screen	Display flow rate, totals, and relay status	Set a screen to display rate, total 1, total 2, and relay status.

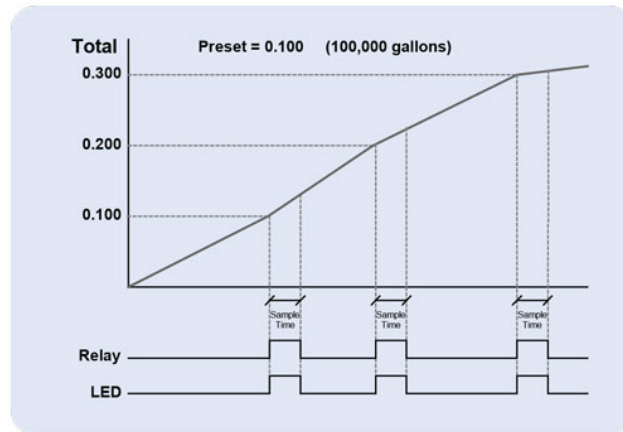

Figure 26. Total Relay Sampling Operation

Setup Math Functions

There are many math functions that can be applied to any channel, which allows the execution of simple or complex math functions. Math channels can be the source for other math channels, totalizers, alarms, and analog outputs.

List of Math Functions

1. Constant
2. Summation
3. Difference
4. Absolute Difference
5. Absolute Value
6. Average*
7. Weighted Average
8. Multiply
9. Divide
10. % Efficiency

*Average can be used for applications requiring redundancy sensors by selecting the *Exclude Fail Input* feature. Both 4-20 mA inputs must be set to break below a fail level value.

Additional Functions

Scale

- K-Factor
- Scale Factor
- Scale Linear 2-Pt
- Scale Multi-Point
- Scale Square Root
- Scale Exponent
- Round Horz Tank
- Units Conversion

Compare

- Greatest
- Least

Measure

- Tare
- Maximum
- Minimum
- Percent (Bargraph)
- Duration
- Rate of Change

Filter

- Window Average
- IIR (First Order)
- Cutoff
- Limits

Control

- Sampler
- On-Off Control
- Select (A or B)
- Schedule

Relays

- Cycle Count
- Runtime

Modbus

- Time Since Read
- Time Since Write

Application: % Efficiency

Description: Calculate the VOC Destruction Efficiency in a Thermal Oxidizer

$$\text{Thermal Oxidizer Efficiency} = (\text{Inlet VOC} - \text{Outlet VOC}) / \text{Inlet VOC}$$

4-20mA output = 0-100% efficient

$$\text{Efficiency} = ((\text{Ch1} - \text{Ch2}) / \text{Ch1}) * 100$$

Ch1 = Inlet VOC

Ch2 = Outlet VOC

AO-1 Source = Ch 20. VOC %Efficiency

AO-1 Scale: 4-20 mA = 0-100% efficiency

VOC: Volatile Organic Components

Select math function for % Efficiency and press **Ok**.

Enter the input sources for the math function, select the units and number of decimals, and press **Ok** and **Save**.

Setup Totalizers

The totalizers are setup the same way as the channels. The rate from an analog or pulse input channel is integrated over the specified time unit to generate an accumulated total that can be configured to count up or count down. Each total may be configured as “non-resettable”*, which means the total reset functions are not available for it.

The pulse inputs can be either integrated from a rate channel or they can be directly totaled based on the pulse count and K-Factor value; this is the most accurate method because every pulse is counted.

**Note:*

The non-resettable function can be disabled by the user at any time, after unlocking a password-protected controller.

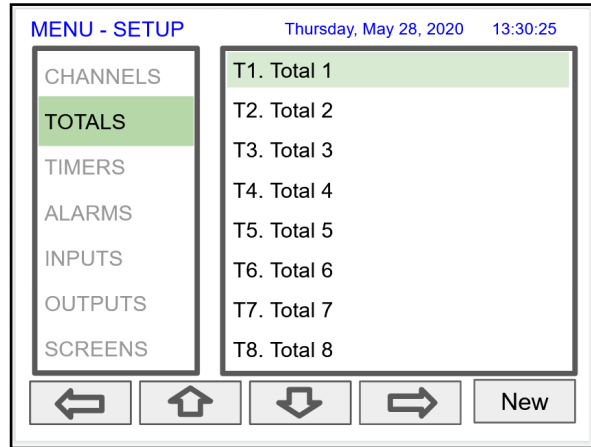

Setup Total with Rate Source

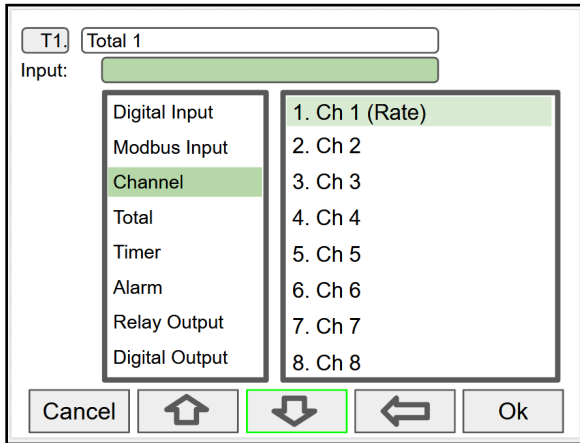

Select the rate input channel for the total and press **Ok**.

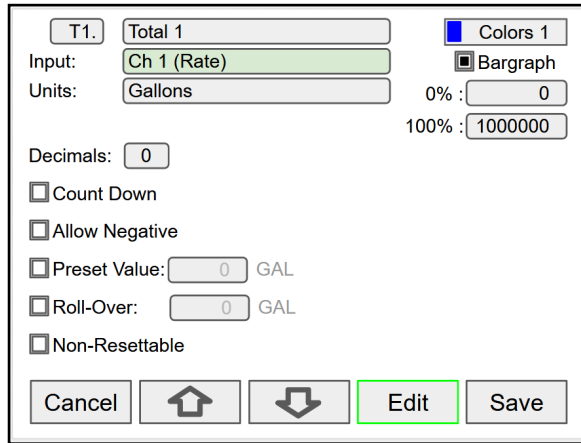

Select total units, count up or down, enter preset and roll-over values, and select non-resettable if required. *After pressing Save, press Yes to reset the total to the preset value.*

Setup Total with Pulse Input Source

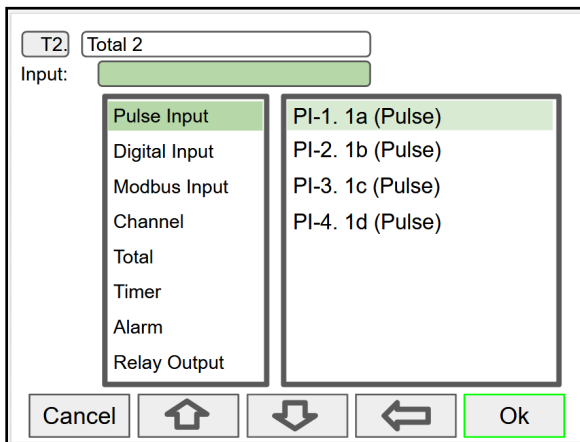

Pulse inputs can be totaled directly without the need to create a rate channel.

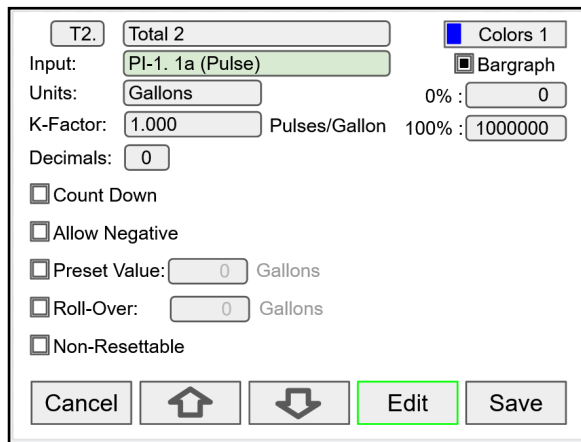

Select the units and enter the K-Factor provided by the flow meter manufacturer.

Setup Timers

Up to 32 timers may be setup to control and monitor various processes. The timers may be triggered by any input or output, such as an analog input rising above a certain threshold or a digital input going from low to high.

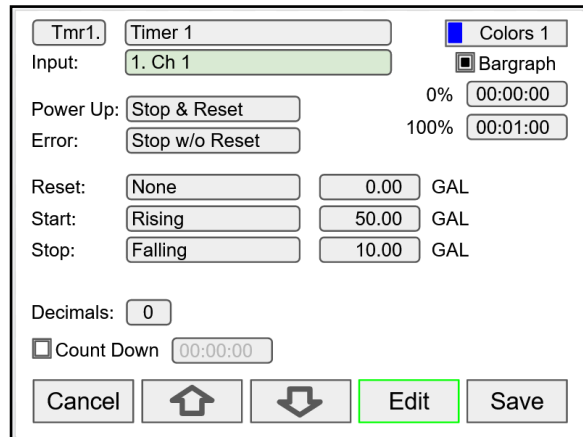
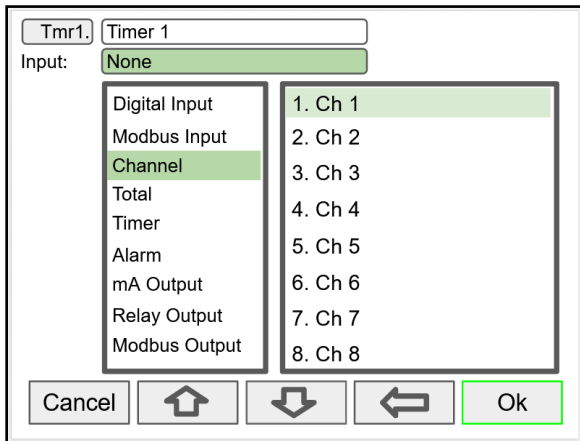
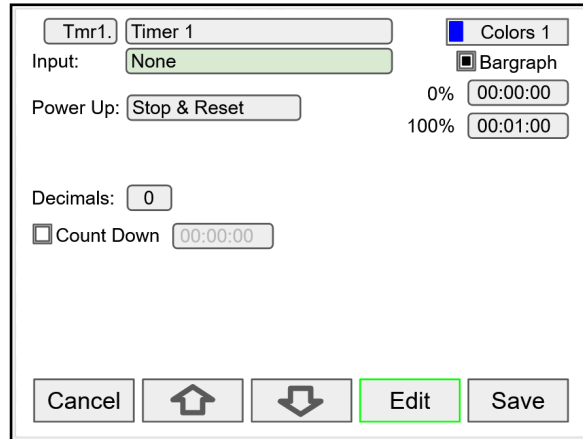
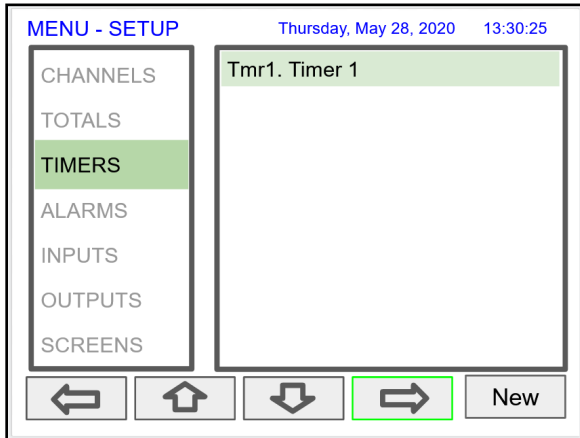

Timer Automatic Actions

The automatic timer actions are:

- Power Up: Timer action on power up
- Error: Timer action when an error is detected
- Reset: Event that causes the timer to reset
- Start: Event that triggers the timer to start
- Stop: Event that causes the timer to stop

Timer Function Keys & Digital Inputs

The function keys and digital inputs may be used to start, stop, and reset the timers, regardless of the automatic actions selected.

Time Format

The time format is hh:mm:ss with 0 decimals selected. If decimal is other than 0, the time is displayed in seconds with the number of decimals selected.

Count Down Timer

Select count down and enter the starting time count.

Timer Bargraph

The bargraph scaling follows the time format selected based on decimal point.

Timer Colors

Select the colors for normal and alarm conditions.

Timer Alarms

Alarms may be setup to trigger on timer values, counting up or down. Go to the *Alarms* menu and select a timer as the source for the alarm.

Setup Alarms

The system is capable of handling up to 64 alarms; they can be driven by a single channel, multiple channels, digital inputs, time interval, or a combination of other alarms into logic AND & logic OR alarms. Set and reset point values determine if it is a high or low alarm and the dead band. Alarms may be setup as latching or non-latching (automatic) with on and off time delays.

1. Tag: 15-character user-defined
2. Type: Select alarm type
 - Single Source
 - Multi-Source
 - Time Interval
 - Alarms OR
 - Alarm AND
3. Input: This will depend on type selected
 - Type: Single and Multi-Source
 - Digital
 - Modbus
 - Channel
 - Total
 - Timer
 - Type: Alarms AND & OR
 - Inputs: Other alarms
4. Automatic: Resets when PV crosses the reset point
5. Ack Anytime (Latching): Ack alarm anytime
6. Break: Alarm status when sensor/comm. break is detected (e.g. Input < 0.01 mA)
 - Alarm On
 - Alarm Off
 - Stay (Maintain the state before the break)
7. On/Off Delays

Multi-Source Alarm

This alarm type behaves as a logic OR; if any of the sources crosses the set point, the alarm goes on.

If the first source is digital (logic), only sources with digital value (on = 1, off = 0) are available for selection.

If the first source is a PV channel or timer, digital inputs may be added as source.

Latching & Non-Latching Alarms

Reset (Ack)	Ack Anytime	Automatic
Auto & Manual	X	X
Auto Only	0	X
Manual Only	X	0
Manual Only After Cleared	0	0

Automatic reset and Ack anytime
Relay assigned to Horn activates on alarm condition

Automatic only: Alarm resets automatically at the reset point

Latching: Acknowledge only after the alarm condition has cleared

Manual Ack (Latching): Select Ack Anytime only

Logic OR Alarm

The inputs for the logic OR alarm are any existing alarms, regardless of the source or type.
 Any active alarm in the group triggers the OR alarm.
 The OR alarm can be used as a summary alarm.

Logic AND Alarm

The inputs for the logic AND alarm are any existing alarm, regardless of the source or type.
 All alarms in the group must be active to trigger the AND alarm.

Logic NOR & NAND Alarms

To create a NOR alarm, select an existing OR alarm and apply the **Not** function available during Setup – Edit.
 The same applies to the NAND alarm.
 Any input alarm may be inverted (Not) to create a specialized alarm logic.

Setup Inputs

The *Setup Inputs* screen is used to configure the hardware inputs, assigning a user-defined tag, and setting filter values.

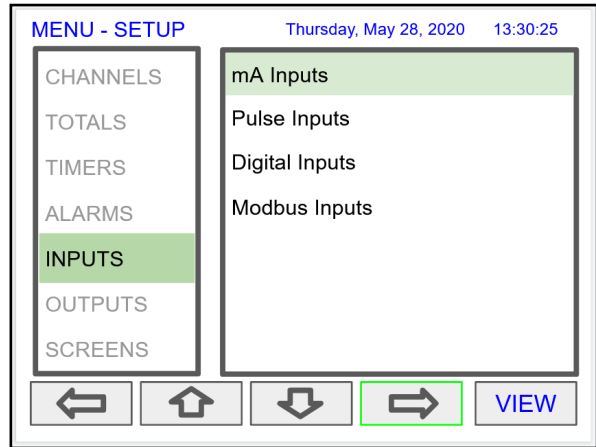

Setup 4-20 mA Inputs

The top line, for each input, shows the slot # and input location (2b = slot #2, second input from the left). It also shows the actual current input.

The next line shows the input type and # (AI-2) with the default tag, which can be changed at any time.

- Filter*: Select filter time
- Bypass: If the signal change is greater than the bypass value, the reading jumps to the actual value \pm Bypass % of full scale.
- Glitch Filter: Eliminates short duration noise spikes
- Break Below: Set the mA value at which a break is reported to the system.
- Disable Input Channel: This turns off the power to the input, but the settings are saved for future use. This should only be used to save power on unused inputs.

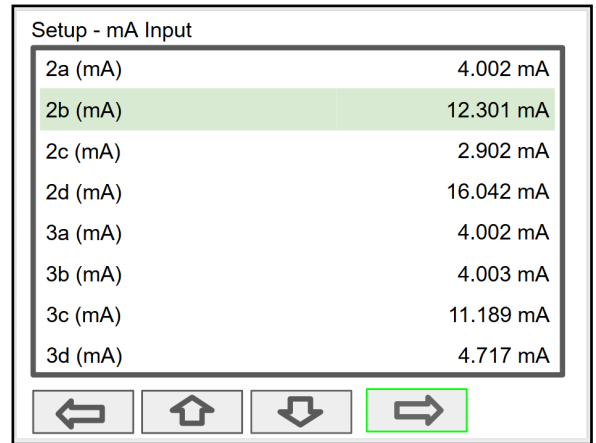

**Need more filtering?
If you need a more stable reading,
select IIR 16 sec or IIR32 sec setting.*

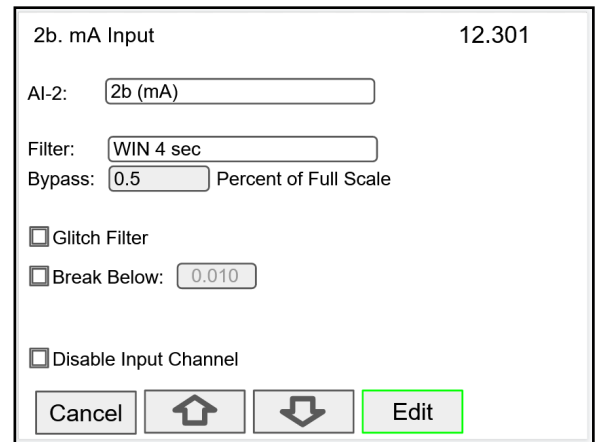

Setup Pulse Inputs

The top line, for each input, shows the slot # and input location (1a = slot #1, first input from the left). It also shows the actual frequency, state of the input, and the number of pulses received since power up, to a maximum of 65,535.

The next line shows the input type and # (PI-1) with the default tag, which can be changed at any time.

- Type: Select the pulse input type.
- Low Gate: this is the time window used to calculate and update the rate.
- High Gate: This is the time window used to calculate slow rates before the rate goes to zero.
- Low Speed: This setting is used as a de-bounce filter for contact closure or switch inputs.

Threshold:
 Is the voltage level at which a transition from high to low is detected. For example, the "Active 1.2V Thrshld" setting will detect a square wave signal when it falls below 1.2 V.

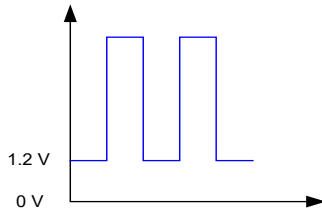

1a: Pulse Input 9999.99 Hz

Counter: 065535

PI-1:

Type:

Low Gate:

High Gate:

Low Speed, 100 Hz max

1a: Pulse Input

PI-1:

Type:

Low Gate:

High Gate:

Low Speed, 100 Hz

Active 1.2V Thrshld

NPN 1.2V Thrshld

PNP 1.2V Thrshld

Reed Switch

Coil 20 mV Thrshld

Active 2.5V Thrshld

NPN 2.5V Thrshld

PNP 2.5V Thrshld

Coil 100 mV Thrshld

Setup Digital Inputs

The digital inputs may be assigned to perform various user functions, such as trigger alarm, acknowledge alarms, reset total, etc.

Pulse inputs may be used as digital inputs by setting them up according the type of input they are intended to accept. For example, to accept a contact closure the pulse input must be setup for *Reed Switch* type input.

Setup Digital Input

DI-1. Digital Input 1	OFF
DI-2. Digital Input 2	ON
DI-3. Digital Input 3	OFF
DI-4. Digital Input 4	OFF
DI-5. Digital Input 5	ON
PI-1. 1a (Pulse)	ON
PI-2. 1b (Pulse)	ON
PI-3. 1c (Pulse)	ON
PI-4. 1d (Pulse)	ON

Digital Input Functions

Digital Input

DI-1:

Active Low

Function:

Digital Input

DI-1:

Active

Button	Ack Alarm
Channel	Reset Alarm
Total	Set Points
Timer	
Alarm	
Screens	
Simulate	
Horn	
Relay	

A digital input can be used to execute one of the listed functions and at the same time, it can be used to trigger an alarm or to totalize (count) how many times the function has been executed (e.g. Reset Total).

- None: Use digital input (DI) to trigger an alarm or timer
- Button: Digital input behaves as a front panel button
- Channel: Tare, Reset Tare, Reset Max, Reset Min
- Total: Access total functions
- Timer: Access timer functions
- Alarm: Access functions (Ack, Reset, Set Points)
- Screen: Next, Previous, Stop/Scan
- Horn: Silence, Snooze, Test
- Relay: Reset relay information

Digital Input

DI-1:

Active

Ack Alarm	All
Reset Alarm	A1. High Alarm 1
Set Points	A2. High Alarm 2
	A3. High Alarm 3
	A4. High Alarm 4
	A5. High Alarm 5
	A6. High Alarm 6
	A7. High Alarm 7

Note: The elements to be acted upon must be created before trying to setup the digital input; otherwise it is not available in the list of functions to execute. For example, to assign the digital input to tare a channel, a Tare Channel must be created first.

*Alarm Reset: The alarm condition is cleared, allowing the alarm to trigger again based on input.
 Acknowledge: Input must cross reset point to trigger new alarm.*

Setup Modbus Inputs

The controller can accept up to 199 Modbus inputs that may be used as the source for channels, math functions, alarms, relay control, etc. Once the data type is selected, the register number is display to the right.

- Enter Modbus Input tag
- Type: Select the data type
- Decimals: Number of decimals
- Units: Select units or enter custom unit
- Break: Value or condition for comm. break
- Timeout: Select timeout to detect break
- Input Action: Select action when new value is received (e.g. Add to Total 1 the value written)

Data Types

- Bit – Logic (Coil)
- Signed/Unsigned 16 (Short), 32 (Long), 64 (Long Long)
- Float 32, Float 64 (Double)

MB-1.

Type: Reg. No. 46701, 46702

Decimals:

Units:

Break: Default: GAL

Timeout:

Input Action:

Setup All Outputs

The Setup Outputs screen is used to configure the hardware outputs, assigning a user-defined tag, scaling the mA outputs, associating relays with alarms, and configuring the digital outputs.

- mA Output: Configure analog outputs
- Relay Output: Configure relay outputs
- Digital Output: Configure digital outputs
- Modbus Output: Configure Modbus outputs

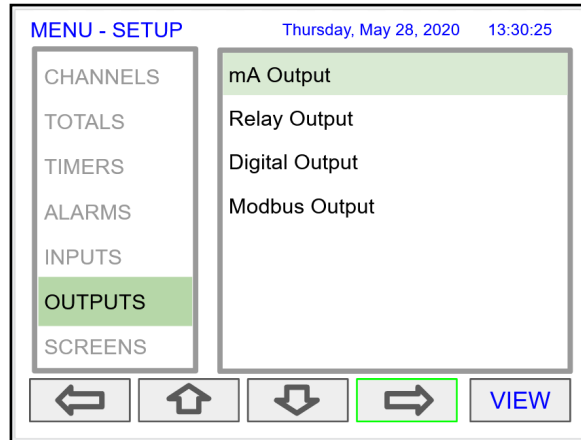

Setup 4-20 mA Outputs

The mA output may be assigned to any analog input, channel, alarm, or digital input. It may be scaled to any input and output value.

The top line indicates the slot # and position of the analog output (4a = slot #4, first position from the left). It also displays the actual mA output.

- AO-1: Analog output 1
- Input: Select source for the mA output
- Scale: Enter input and output values
- Break: mA output when sensor or communications break is detected
- Minimum: The minimum output allowed
- Maximum: The maximum output allowed
- Slew Rate: Rate of change in mA/sec
- Underrange: mA value when the PV goes below the low range value by more than 1%.
- Overrange: mA value when the PV goes above the high range value by more than 1%.

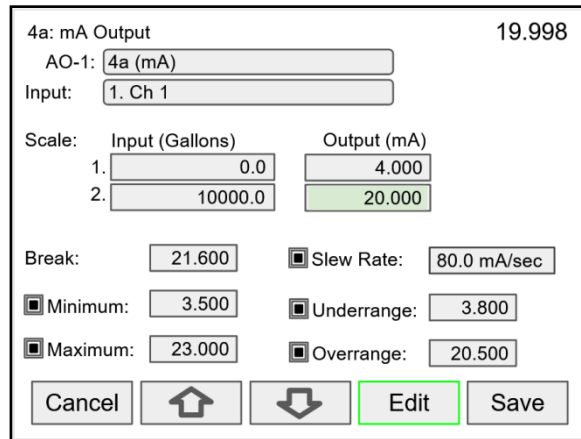

Setup Relay Output

The relays can be driven by alarms, digital inputs, Modbus inputs, channels, totals, and timers. If the input source is a channel, set and reset points must be entered. These are the available settings depending on the source selected.

- Input: Select the source to drive the relay
- Set & Reset: Enter values to turn on & off the relay for Channel, Total, or Timer Input
- Pulse Output: Pulse relay on/off when set is active
- Break*: The relay state when break is detected
- Fail-Safe: Relay energized under normal conditions
- Relay Status & Runtime: hh:mm:ss

*Function: Select **Other** to set relay to always on, always off, drive a relay-horn, or to alternate with another relay.*

Setup Relay Output	
RY-1. Relay 1	ON
RY-2. Relay 2	ON
RY-3. Relay 3	OFF
RY-4. Relay 4	OFF
RY-5. Relay 5	ON
RY-6. Relay 6	ON
RY-7. Relay 7	OFF
RY-8. Relay 8	OFF
RY-9. Relay 9	ON
RY-10. Relay 10	OFF

The F4 key may be used to momentarily turn on/off the relays. To manually control the relays, go to the View Menu to set the relay to be permanently on or off.

Select the input source to drive the relay and enter the required parameters according to the input.

6a: Relay Output

RY-1:

Input:

Digital Input	A1. High Alarm 1
Modbus Input	A2. High Alarm 2
Channel	A3. High Alarm 3
Total	A4. High Alarm 4
Timer	A5. High Alarm 5
Alarm	A6. High Alarm 6
Other	A7. High Alarm 7

Relay Assigned to Alarm

6a: Relay Output

RY-1: Runtime: ON

Input:

Enable Alternation

On Delay: sec

Off Delay: sec

Pulse Output

On Time: sec

Off Time: sec

Fail-Safe

The relay runtime & cycle count can be reset (cleared) from the relay setup screen.

**Note: Break needs to be set in the analog input menu.*

Relay Assigned to Channel

6b: Relay Output

RY-2:

Input:

Enable Alternation

Set (On): GAL/sec On Delay: sec

Reset (Off): GAL/sec Off Delay: sec

Pulse Output

Break: On Time: sec

Fail-Safe Off Time: sec

Relays not assigned to alarms are used for automatic on/off control based on set & reset point; they cannot be acknowledged.

Pump Alternation Relays

To setup a group of relays for pump alternation control, follow these steps.

1. Select the primary alternating relay
2. Select the input for alternation (e.g. Ch 1)
3. Enable alternation
4. Enable alternate on time and enter time
5. Enter the On & Off alternation points according to the number of relays to alternate
6. Select relay condition when input break is detected*
7. Select fail-safe, if desired (Reverses the relay contacts state: NO closes and NC opens)
8. Enter the On & Off time delays
9. After saving the primary relay configuration, navigate to the next relay and configure it to alternate with the primary relay

Alternation Input Sources

Most level control applications use channels as the input. The channel is setup to read the signal from a level transmitter and display the level either in height or volume units. The continuous level monitoring allows for selecting multiple alternation points.

If the input is other than a channel, the alternation is limited to only one pump on at one time. A level switch could be connected to a digital input and the digital input will alternate the pumps for each on/off cycle.

Set (On) & Reset (Off) Points

Up to eight alternation points may be entered to alternate eight relays per group. The On & Off points determine if pumps are on when the level rises or when it falls.

On & Off Time Delays

To prevent turning pumps off and on at the same time, it's recommended to use On delays. The On & Off delays are common to all the relays in the alternation group.

Alternation Groups

An alternation group is made up of a primary relay and any number of relays selected to alternate with it.

Multiple alternation groups may be setup using different sources for each group. A relay should NOT be assigned to more than one group.

Alternate on Time

This is the maximum time any relay in the group will be continuously on. After the alternation time has elapsed, the relay will turn off and another relay will turn on. This feature is useful for applications where the level is maintained with one pump for a long time. Depending of the setup and conditions, it will help distribute the load among the pumps in the group.

Break

If *Relay On* is selected, only one of the alternation relays will be on when a break is detected*.

*Note: Break needs to be set in the analog input menu.

	Set (On)	Reset (Off)
1.	40.00	25.00
2.	60.00	45.00
3.	80.00	65.00
4.	100.00	85.00

Setup the primary alternation relay.

Setup the additional alternation relays.

Select the primary relay to alternate with.

Alternation Sequence

The first relay on is the first relay off, when more than one relay are activated. The lowest reset point (Off) is used for the alternation cycle.

Setup Digital Output

The Digital Output menu allows assigning the 4 outputs to various events generated by digital inputs, On/Off channels, alarms, and horn on state.

- Edit the digital output tag
- Select the input
- Select the Break condition
- Invert Output logic

Setup Modbus Output

The *Modbus Output* menu allows assigning up to 64 Modbus register sets (1 to 4) to output any of the values available in the system (e.g. PV channels, Totals, Relay Runtime, etc.) and selecting the desired data type from bit-logic to float 64.

The function code is 0x03 and the registers are base-1 (e.g. Reg. Address 4400 = Reg. Number 44401).

- Edit the Modbus Output tag
- Select the source for the output
- Select the data type
- The register number is assigned by the system

Select the input for Modbus Output.

Select the data type.

The register number is provided for each data type.

Setup Screens

The *Setup Screens* menu is used to setup the screens that will be displayed during operation and to setup the actions assigned to the function keys F1-F4.

Screens Settings

Up to eight PVs and/or alarms may be displayed per screen. The screens can be setup to scan automatically, display bargraphs, and program the function keys to be used while the screen is visible.

These are the available settings:

- Title: User-defined title or tag
- Channels and alarms: Up to eight/screen
- Show Title: Select to display the title
- Show Channel #: Select to display the channel #
- Show Bargraphs: Select to display the bargraphs
- Bargraph Only: Select to display only the bargraphs
- Auto Scan: Select to scan the screens automatically
- Dwell Time: Number of seconds the screen is displayed before moving to the next screen
- F1 – F4: Assign functions to be executed by the function keys

Note:

The function keys F1 – F4 can be customized according to the screen in view.

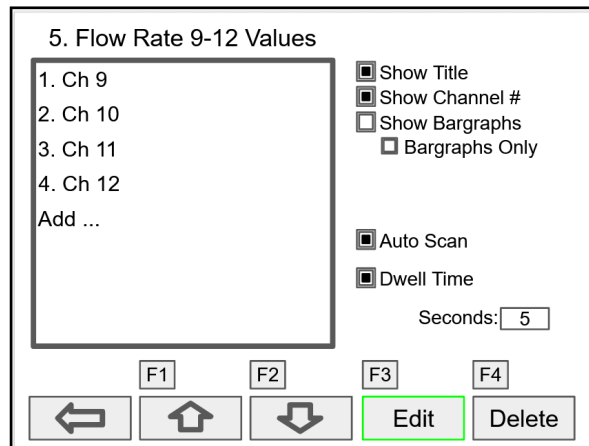
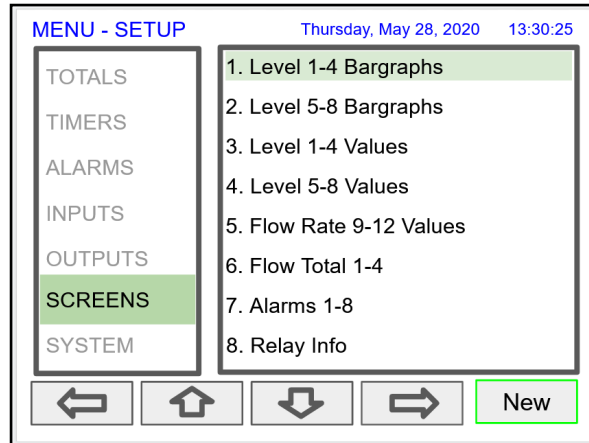

Setup Function Keys

The function keys are setup independently for each screen; this allows the customization of the function keys according to the process values being displayed. For example, if totals are being displayed, one function key can be setup to reset one or all totals.

Note:
 Functions are available for selection only if the appropriate parameter has been set up. Example: If there are no channels with Tare, Max, or Min, Channel will not appear in the list for selection of a function.

- Channel
 - Tare (If applicable)
 - Minimum
 - Maximum
- Total
 - Reset Total
 - Reset (Confirm)
 - Enter Total
 - Add To
 - Remove From
- Timer
 - Timer Control
 - Reset
 - Start (Reset)
 - Start (No Reset)
 - Stop (Reset)
 - Stop (No Reset)
 - Start (R) / Stop
 - Start / Stop
 - Start / Stop (R)
 - Start (R) / Stop (R)
 - Start / Reset
 - Stop / Reset
- Alarm
 - Ack
 - Reset Alarm
 - Set Points
- Screens
 - Previous Screen
 - Next Screen
 - Scan / Stop
 - Go to Screen
 - View Channel
 - View Total
 - View Timer
 - View Alarm
 - View Date & Time
 - View mA Input
 - View Pulse Input
 - View Digital Input
 - View Modbus Input
 - View mA Output
 - View Relay Output
 - View Digital Output
 - View Modbus Output

Note:
 The View function can be used to go to any of the listed parameters or to the View screen for all parameters of the same type (e.g. View - all the channels).

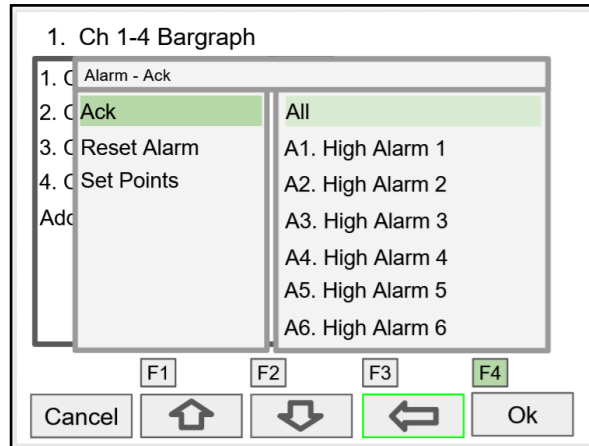

F4 Assigned to Acknowledge All Alarms

- Simulate
 - mA Input
 - Pulse Input
 - Digital Input
 - Modbus Input
 - Channel
 - Total
 - Timer
 - Alarm
- Horn
 - Silence
 - Snooze
 - Test
- mA Output
 - Manual
 - Hold (Manual)
 - Automatic
 - Manual / Auto
 - Hold / Auto
- Relay
 - Reset Info
 - Reset Info (Confirm)
 - Force ON
 - Force OFF
 - Manual ON
 - Manual OFF
 - Hold (Manual)
 - Automatic
 - Manual ON / Auto
 - Manual OFF / Auto
 - Hold / Auto

Setup System

The *Setup System* menu is used to configure settings that are used throughout the system.

Setup Display

The System *Display* menu is used to adjust the display settings, setup colors for parameters, bargraphs, and alarms.

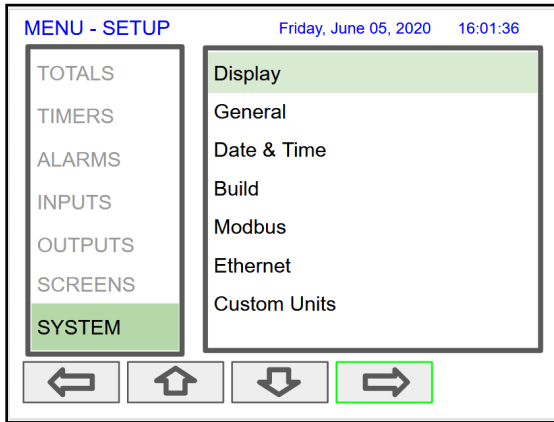

Setup Colors

The *Colors* menu is used to select the colors for text, values, and bargraphs associated with the parameter being displayed.

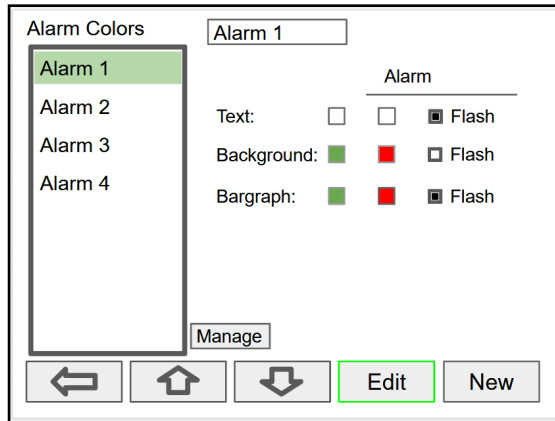
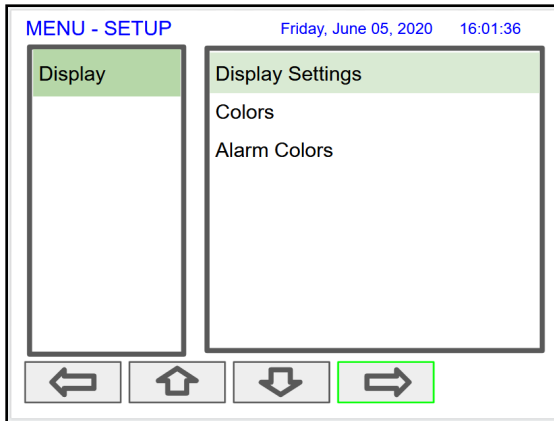
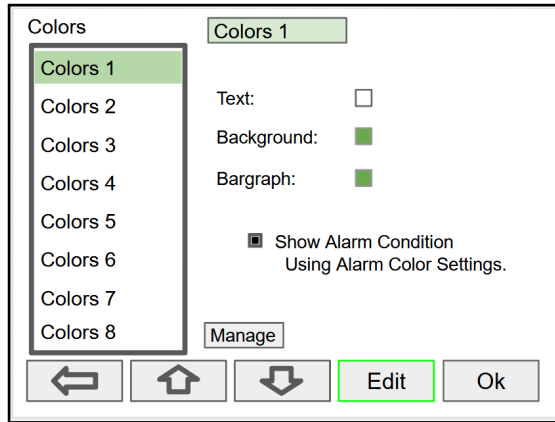

The *Alarm Colors* menu is used to select the colors and behavior of the alarms' text, alarm panel background, and the bargraph indicator for set and reset points.

Display Settings

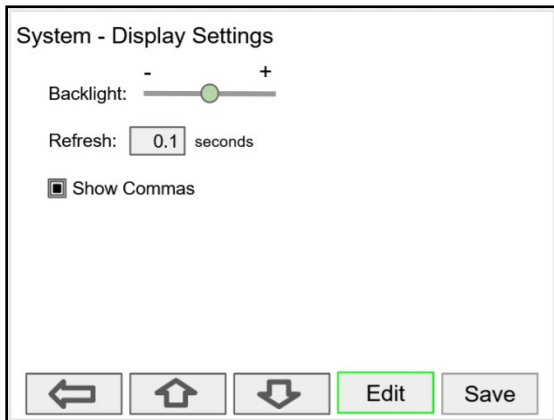

The *Display Settings* menu is used to adjust the backlight brightness, refresh rate and to enable or disable the display of commas for all numeric values.

General Settings

The *General Settings* menu contains the settings listed below.

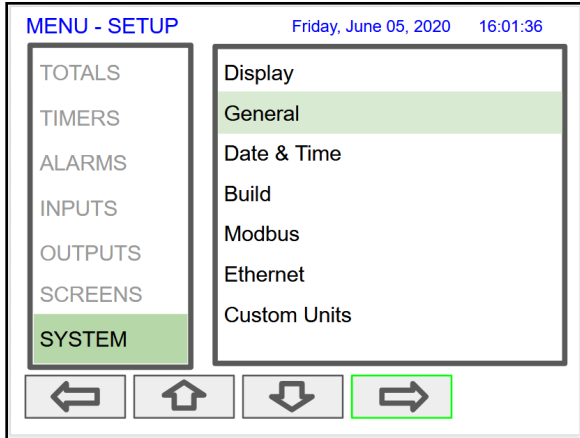

Set Password

The user may enter a 4-digit password to protect the system from unintentional changes.

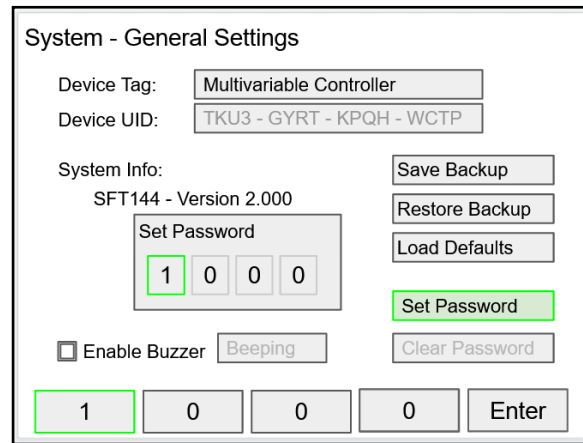
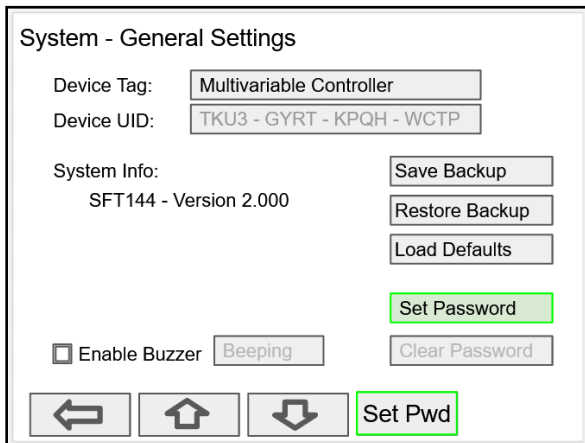
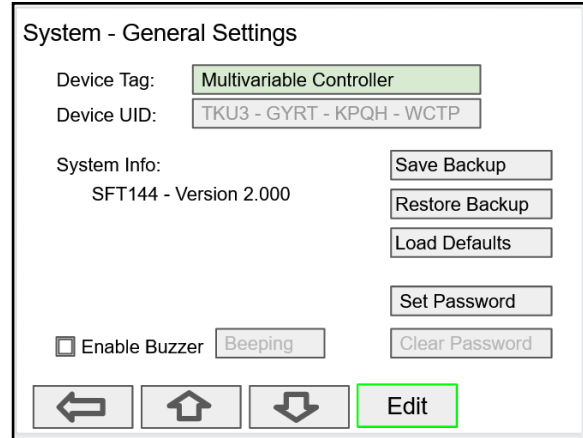

- Device Tag: Edit the device tag (saved on Enter)
- Device UID: Device unique Id
- Enable Buzzer: Enable/disable internal buzzer*
- Save Backup: The current configuration is saved
- Restore Backup: Load backup configuration
- Load Defaults: Load factory defaults
- Set Password: Enter password to lock the system
- Clear Password: Remove the current password

*Buzzer Sound Options:

- Beeping
- Alarm
- Solid
- Warble
- Carousel

Note: The internal buzzer is associated with the alarm's Horn setting, which is available to drive any relay.

Password Protected Controller

The correct 4-digit password is required to make changes to the system.

If the password is not correct after 3 attempts, the system will not allow new tries until a timeout elapses. The timeout will continue increasing for every 3 new unsuccessful tries.

Remove Password Protection

To remove the password protection:

1. Enter the correct password
2. Go to the **System** menu – **General Settings**
3. Navigate to the **Clear Password** button
4. Press the **Clr Pwd** key

CAUTION

- The function keys and the digital inputs are not password protected.

System Date & Time

The date & time of the system can be easily adjusted in the System menu.

System - Date & Time

Date:

Time:

Modbus Settings & Passcode Protection

The *Modbus* settings must be configured to match the settings of other devices on the bus. The Modbus Id must be unique to each device on the bus.

System - Modbus Settings

Mode: Slave Id:

Baud Rate:

1200 bps
 2400 bps
 4800 bps
 9600 bps
 19200 bps
 38400 bps
 57600 bps
 115200 bps

Parity:

Tx Delay: ms

Passcode:

Select **Passcode** and enter a Modbus passcode between 0 and 9999 to prevent unauthorized writes to the controller.

This is different than the main password used to protect access to the *Setup* and *View* menus.

System Build

The *Build* menu provides the model number and it shows the I/O cards installed with their location in the seven available slots.

System - Build

Model Number: PD9000-XY-4PI-8AI-10AO-10RY

Slot #	Description	SFT #	Ver.
1.	(4) Pulse Inputs	146	1.000
2.	(4) 4-20 mA Inputs	145	1.000
3.	(4) 4-20 mA Inputs	145	1.000
4.	(5) 4-20 mA Outputs	146	1.000
5.	5) 4-20 mA Outputs	146	1.000
6.	5) Relay Outputs	146	1.000
7.	5) Relay Outputs	146	1.000

If an I/O card is removed permanently, pressing the *Rebuild* key clears the information from the slot. This should also be done if a different card is installed.

Replacing I/O Cards

In case that an I/O card fails, follow these steps:

- 1) Save a backup copy of the configuration
- 2) Remove the defective card
- 3) Install the new card in the same slot where the defective card was
- 4) It is not necessary to click Rebuild

Ethernet Settings

The *Ethernet* menu provides basic information about the Ethernet port and allows the user to program a static IP Address, the port number, and the protocol to be used.

System - Ethernet Settings

Lantronix XPort Device

MAC Address: 0080A3D50F9E

DHCP (for automatic IP Address)

IP Address:

Port:

Protocol:

Advanced Setup

HTTP Port: 80

Telnet Port: 9999

The settings provided in *System* menu are sufficient to establish Ethernet communications using TCP or UDP protocols.

For more advanced setup, refer to the instructions provided under *Ethernet Port Setup* on page 54.

Note:
 If DHCP is selected, the device obtains a new IP address automatically most of the time when the power is cycled. This is not displayed on the controller.

Ethernet Port Setup - Full

The Ethernet port option is fully configured using the Lantronix DeviceInstaller software, available for download from the Lantronix's Website.

<https://www.lantronix.com/products/xport>

Follow these steps, after installation of the DeviceInstaller software.

1. Connect an Ethernet cable to the Local Area Network
2. Launch the Lantronix DeviceInstaller; it will search for XPort devices on the Local Area Network (LAN) and display their status.
3. If no controller is found, click on **Options**, and select the type of connection being used (e.g. Wi-Fi).
4. If more than one controller is connected to the network, determine which is the new controller by the assigned IP address. If necessary, disconnect the new controller and click **Device – Search**, take note of the IP addresses listed. Next, connect the new controller to the LAN and repeat the search; check the list to see which the new IP address is.

CAUTION

- Consult with your IT department to configure the Ethernet port and maintain network security.



5. Double-click on the new device IP Address to be configured.

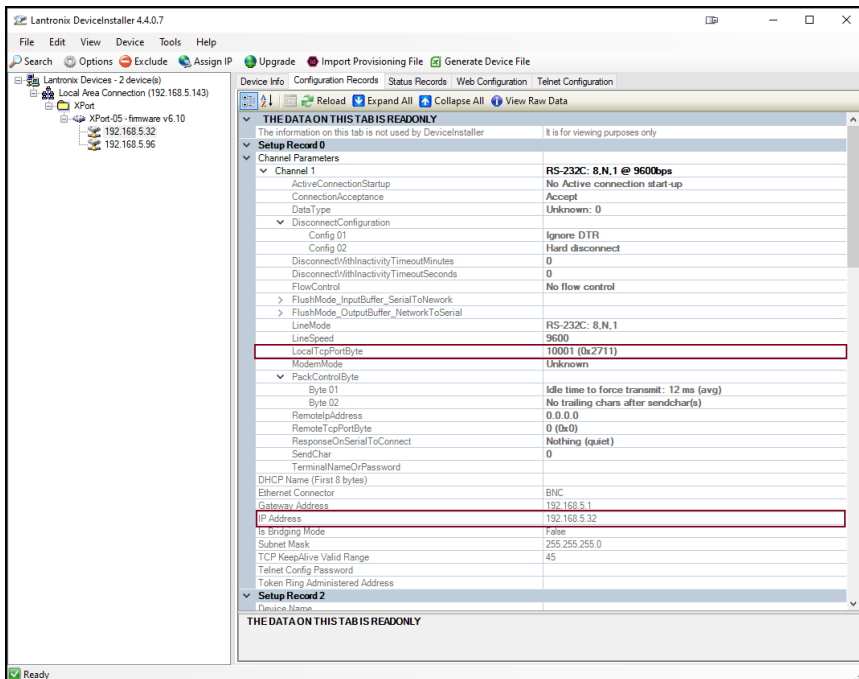

To communicate with a device connected over a LAN, you need the IP Address and the Local TCP Port.

- Click on **Configuration Records** to find these settings, see the example above.
IP Address: 192.168.5.32; Local TCP Port: 10001 (0x2711)

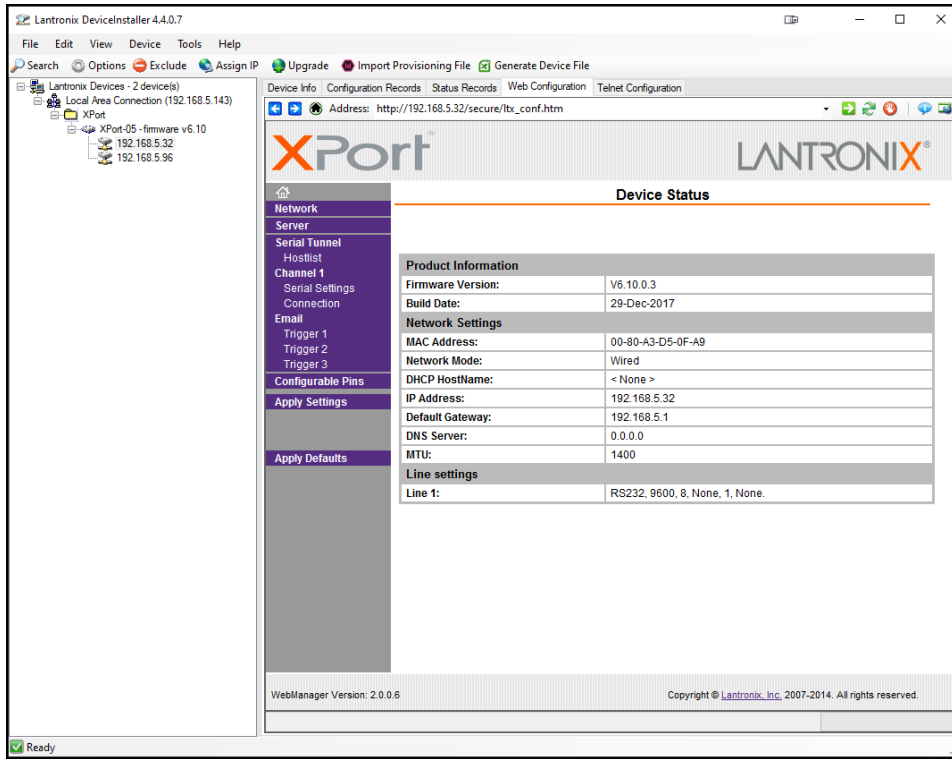

- Click on **Web Configuration**

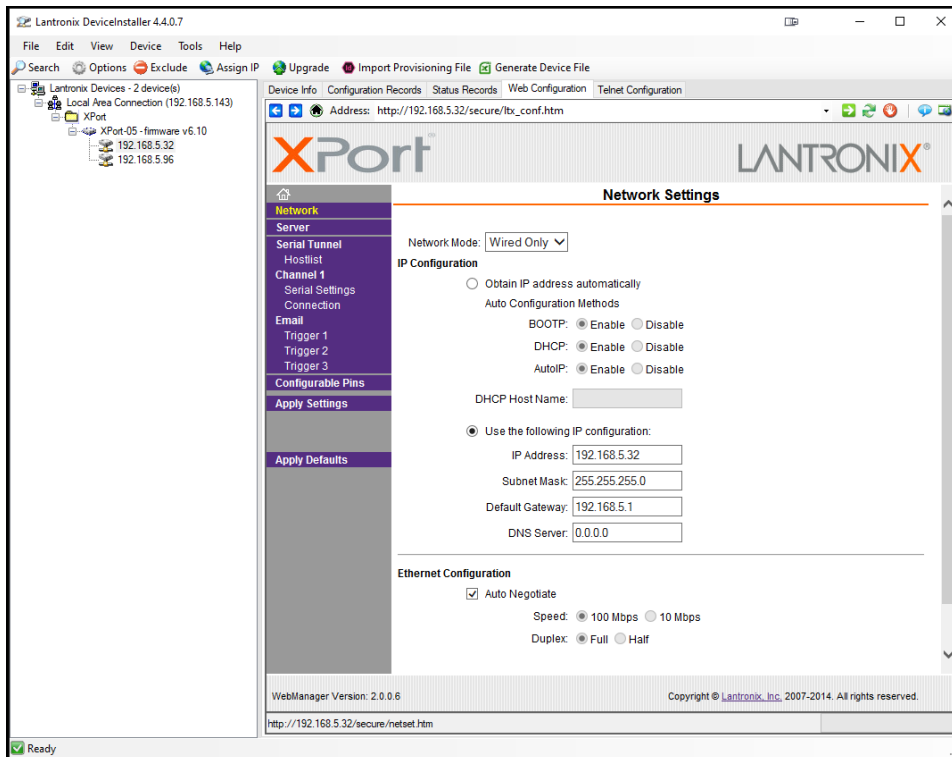

- Click on **Network** to assign a new IP Address

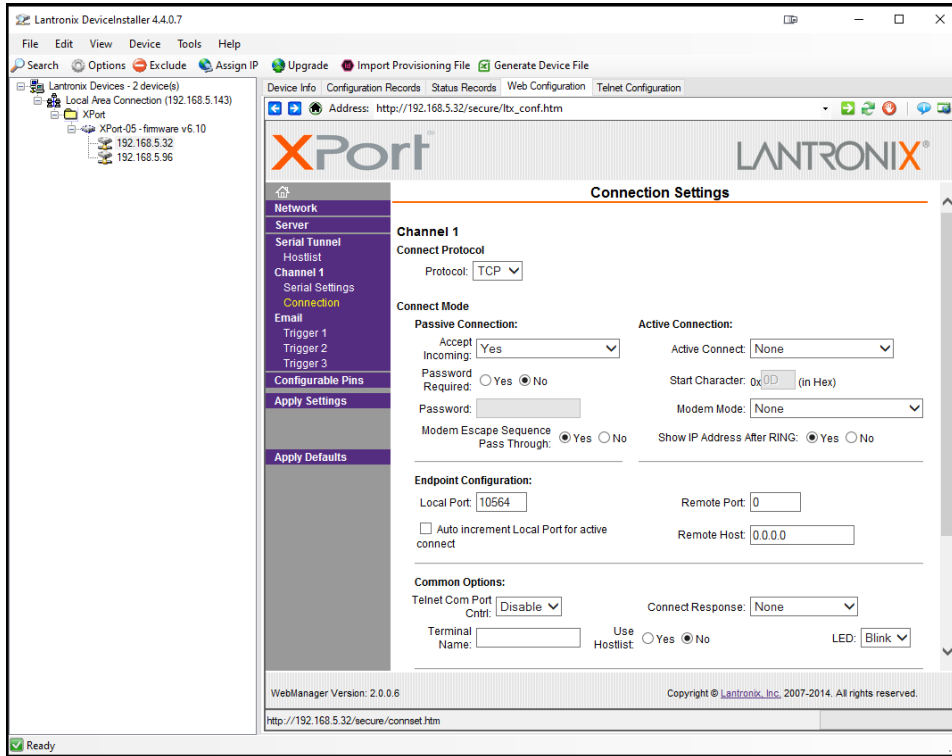

9. Click on **Channel 1 – Connection** to select the protocol: TCP or UDP.
Note: For UDP protocol, select **Datagram Type: 01**
10. Under **Endpoint Configuration**, enter the **Local Port** to be used to access the controller locally or from a remote location. This should be provided by your company's IT department.
11. Click **OK** and then click **Apply Settings** for settings to be sent to the Ethernet device.

Test Ethernet Communication

Modbus Poll is an app that makes it easy to test your Ethernet connection. Below are some screenshot examples for Modbus TCP/IP connection.

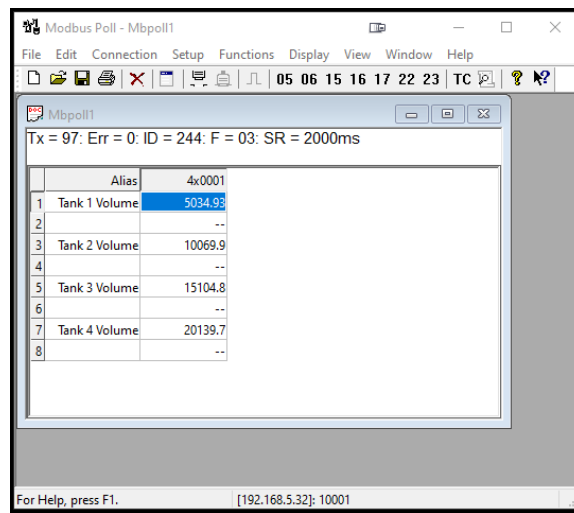
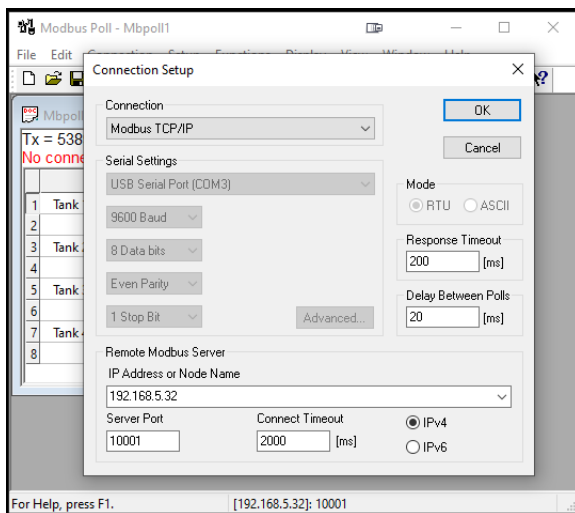

Note: You may download a trial copy of Modbus Poll from <https://www.modbustools.com/>

Custom Units

Custom units can be created either in the System menu or when a parameter is created. Follow these steps to create a custom unit:

- Go to the *System* menu – *Custom Units*
- Select *New*
- Enter a label for the unit (8 characters max)
- Select the unit type or *None*
- Select the base unit
- Enter the conversion factor

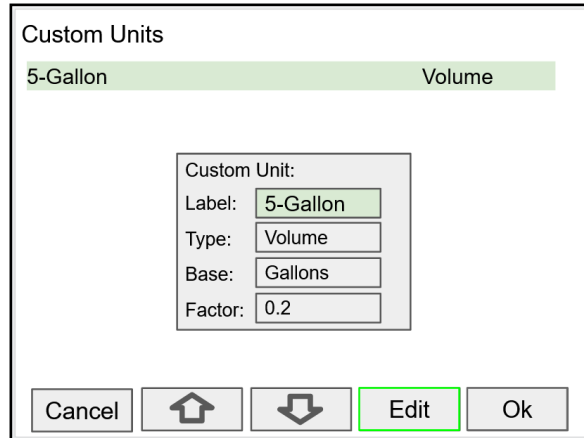

Delete Custom Units

Custom units can only be deleted if they are not been used anywhere in the system.

To delete a custom unit, simply select the unit, navigate to the Delete button, and press *Ok* to delete.

The Delete button is not available if the custom unit is being used.

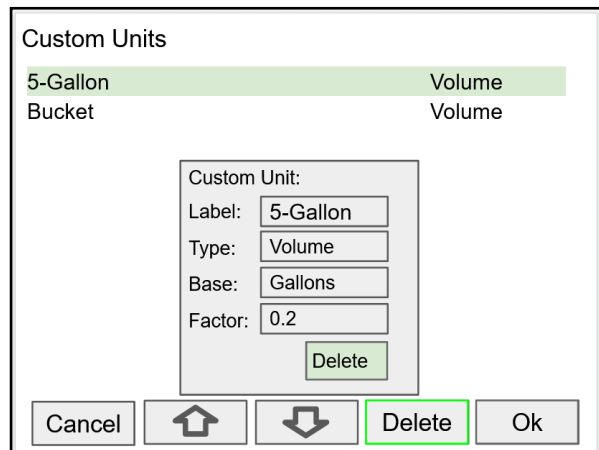

View Menu

The *View* menu is used to view individual channels, totals, timers, alarms, inputs, outputs, and screens. For example, it provides the details for the current PV, what inputs are the sources for the channel and what outputs are associated with the channel.

Accessing the individual parameters through the *View* menu also allows the simulation of the various parameters for testing purposes as well as the manual control of the relays and analog outputs.

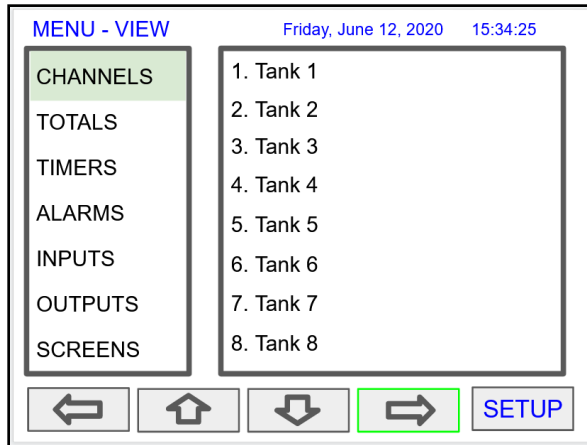

Press the **Right Arrow** key to step into viewing any channel.

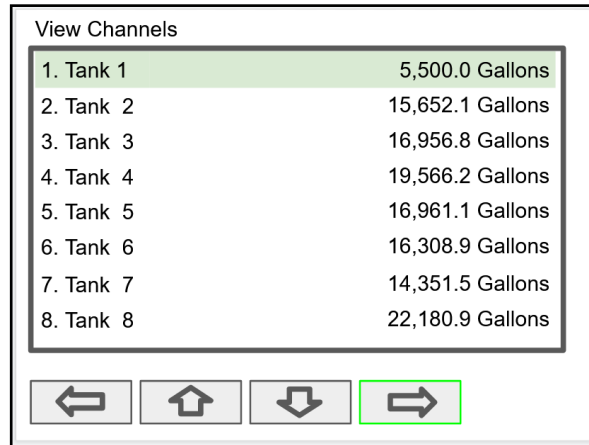

Select any channel using the **Up** or **Down Arrow** keys and Press the **Right Arrow** key again to step into viewing the channel details.

View Channel Details

Stepping into a channel allows the viewing of additional details for the inputs and outputs associated with that channel. It is also possible to simulate the selected parameter.

- Channel number and tag
- PV and units
- View the channel input source
- View alarms associated with channel
- View analog outputs assigned to channel
- Simulate the channel or analog input
- Step into any associated parameter

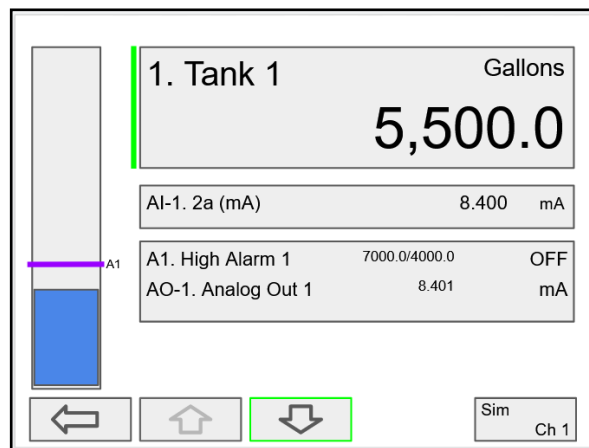

Press the **Down Arrow** key to navigate to the channel input source and then down again to view alarms and analog outputs.

View Associated Parameters

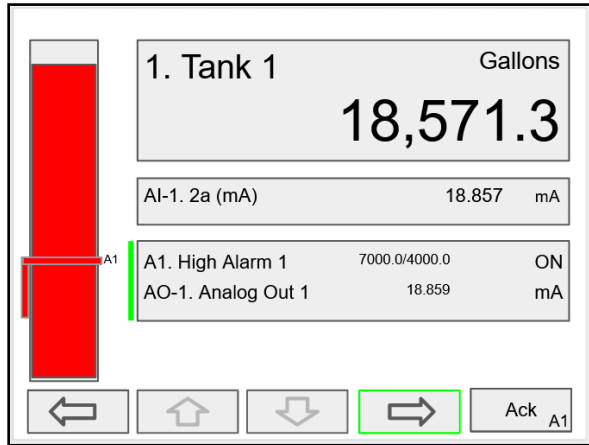

Press the **Right Arrow** key to select the alarm.

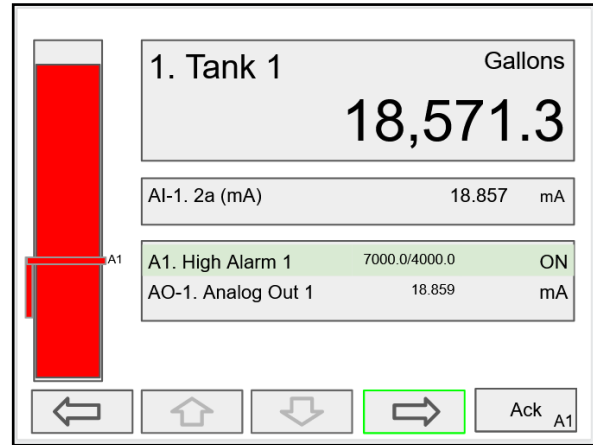

Press the **Right Arrow** key again to view alarm's details.

View Alarm Details

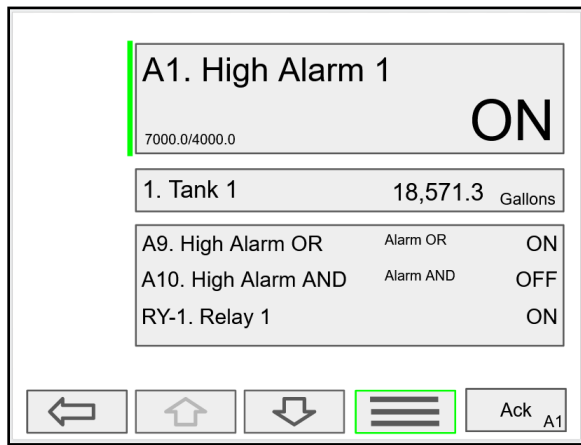

Press the **3-Bar** key to access the available options.

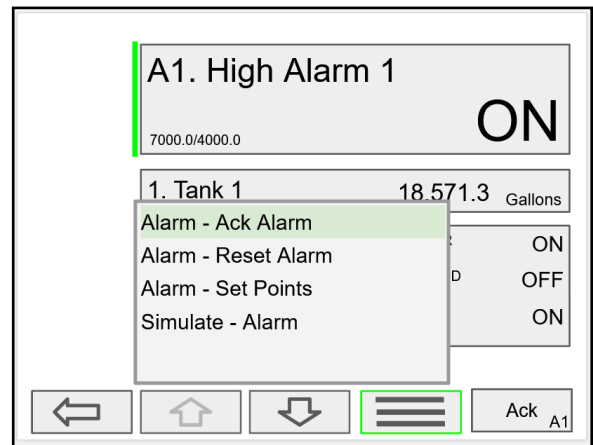

Alarm view options: acknowledge alarm, reset alarm, change set/reset points, and simulate an alarm condition.

View Totals

The *View Totals* menu displays the value of all the totals and allows resetting each total individually.

- Total number and tag
- Accumulated total and units
- Reset total key
- View source for total
- View alarms associated with total
- View analog outputs assigned to total

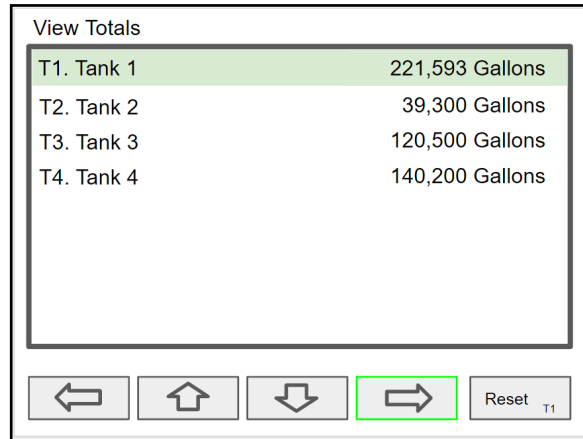

Press **Right Arrow** key to step into details of the selected total and view the source and associated outputs.

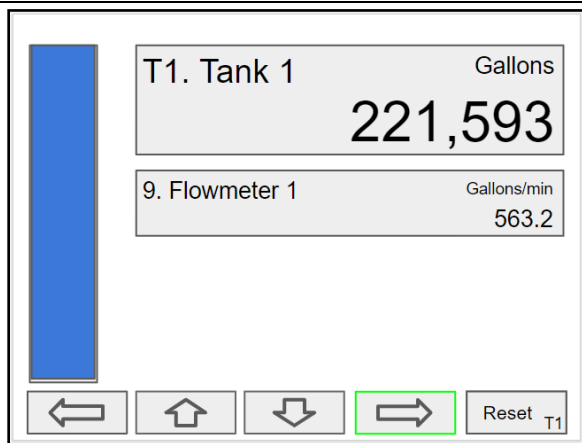

Press the **Right Arrow** key to select Total 1.

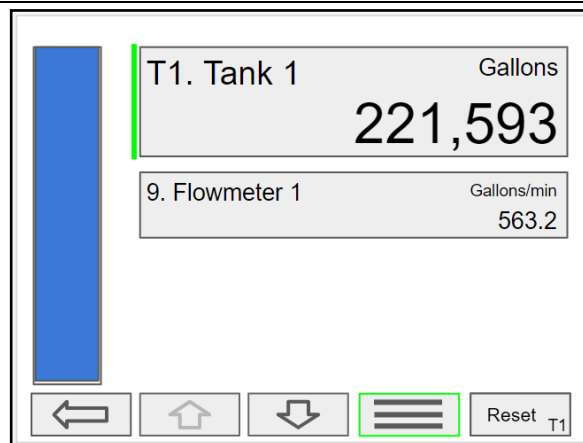

Press the **3-Bar** key to enter a new total, reset the total, or simulate a value for the total.

Totals not associated with a rate channel have additional features: Add to or remove from the total.

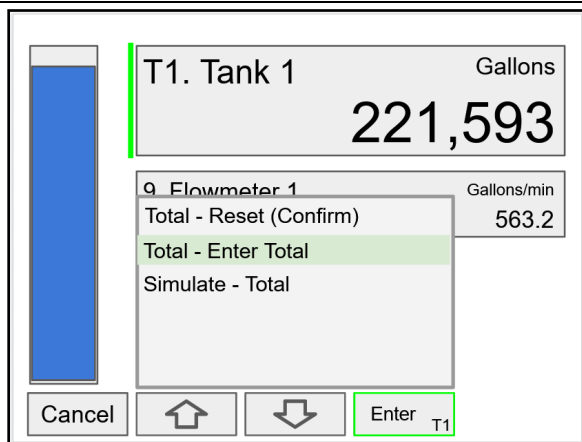

Press the **Enter** key to enter a new total.

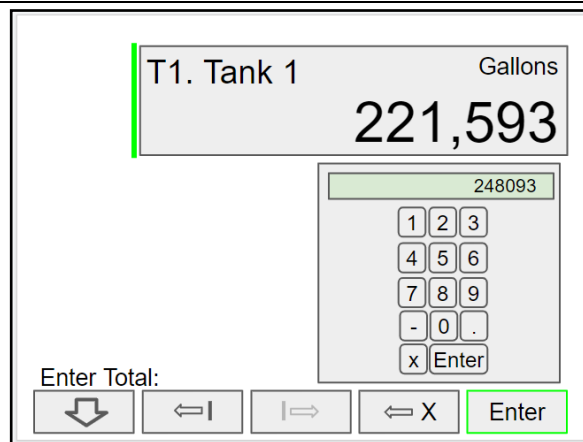

Using the numbers keypad, enter a new total and then press the **Enter** key to save.

Totals Generated by Non-Rate Inputs

For totals generated using non-rate inputs; it is possible to add or remove from the total using the **3-Bar** key on the *View Total* screen.

This type of total requires the use of an external trigger such as a digital input, function key, or a Modbus signal. For example, if the input to T1 is Ch 1, which is displaying the volume in a container, as provided by the weight being measured by a load cell with a 4-20 mA output, which is the input to channel 1.

- Total 1 = 200,500 gallons
- Channel 1 = 100.0 gallons
- Press function key *Add To (+ T1)*
- 100 gallons is added to Total 1

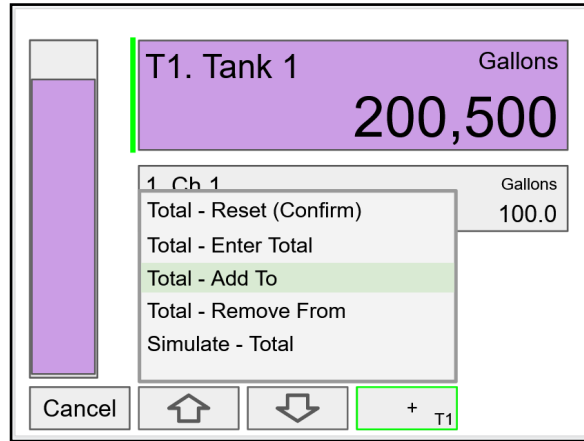

The total in Tank 1 has been incremented by 100 gallons.

The *Remove From* feature can be used to decrement the volume inside a storage tank.

Normally these operations are done automatically by using a proximity switch or a limit switch to trigger the *Add To* or *Remove From* features.

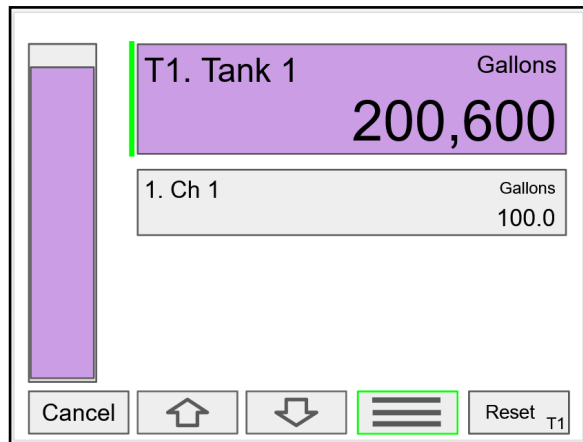

View Timers

The *View Timers* menu displays the value of the existing timers.

Press the **Right Arrow** key to step into the details of the selected timer and view the associated inputs and outputs.

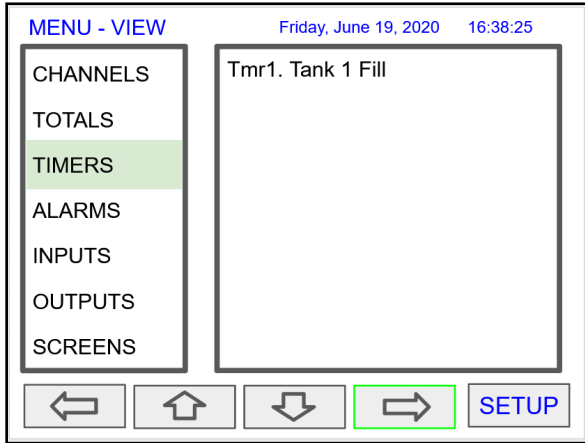

Press the **Right Arrow** key to step into viewing timer.

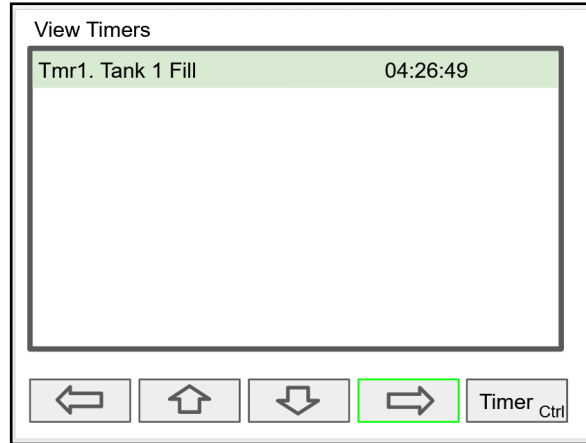

Press the **Right Arrow** key to view timer details.

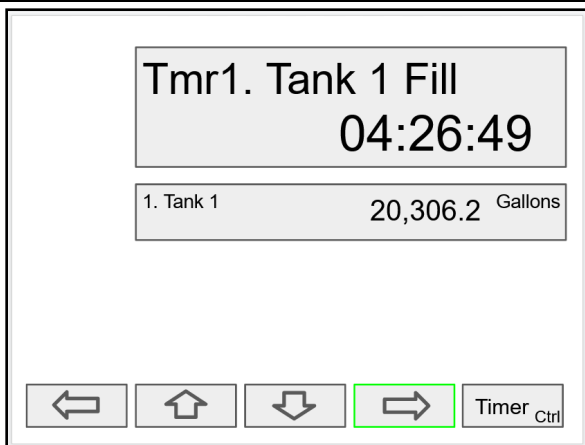

Press the **Right Arrow** key to select timer.

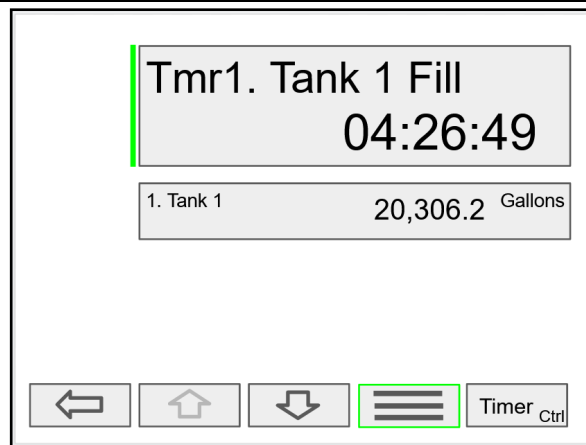

Press the **3-Bar** key to choose Timer Control, Reset, Start, Stop, or Simulate.

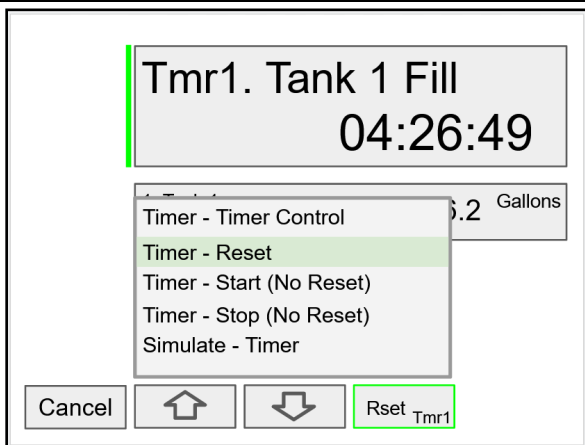

Press the **Reset** key to reset the timer, select *Timer Control* for additional functions. Use the *Simulate* function to simulate the timer rising, falling, or jump to a specific value using the keypad.



Press the **TIMER CONTROL** key (shown in the timer details screen) to access all timer control buttons.

View Alarms

The *View Alarms* menu displays the status of all the alarms and the details for each alarm.

Under the alarm details view, it is possible to reset an acknowledged alarm, change the set/reset points, or simulate an alarm condition.

- Alarm # and tag
- Set/Reset points
- Source for the alarm
- Outputs associated with the alarm
- Acknowledge the alarm
- Reset the alarm
- Simulate alarm condition

View Alarms		
A1. High Alarm 1	7000.0/4000.0	ON
A2. High Alarm 2	7000.0/4000.0	OFF
A3. High Alarm 3	7000.0/4000.0	ON
A4. High Alarm 4	7000.0/4000.0	ON
A5. High Alarm 5	7000.0/4000.0	OFF
A6. High Alarm 6	7000.0/4000.0	ON
A7. High Alarm 7	7000.0/4000.0	OFF
A8. High Alarm 8	7000.0/4000.0	ON

← ↑ ↓ → Ack A1

Press the **Right Arrow** key to view the alarm details.

A1. High Alarm 1
ON

7000.0/4000.0

1. Tank 1	7,190.6	Gallons
-----------	---------	---------

A13. High Alarm OR	Alarm OR	ON
A14. High Alarm AND	Alarm AND	OFF
RY-1. Relay 1		ON

← ↑ ↓ ≡ Ack A1

Press the **3-Bar** key to select Ack Alarm, Reset Alarm, change Set Points, or Simulate Alarm condition.

A1. High Alarm 1
ON

7000.0/4000.0

1. Tank 1	7,190.6	Gallons
-----------	---------	---------

Alarm - Ack Alarm		ON
Alarm - Reset Alarm		ON
Alarm - Set Points		OFF
Simulate - Alarm		ON

Cancel ↑ ↓ Set Pt A1

Press the **Set Point** key to change the Set Points. This re-initializes the alarm to reflect the new set point.

Simulate Alarm Condition

A1. High Alarm 1
OFF

8000.0/4000.0

1. Tank 1	7,190.6	Gallons
-----------	---------	---------

Alarm - Ack Alarm		OFF
Alarm - Reset Alarm		OFF
Alarm - Set Points		OFF
Simulate - Alarm		OFF

Cancel ↑ ↓ Sim A1

Press the **Simulate** key to simulate an alarm condition.

A1. High Alarm 1
ON

8000.0/4000.0

1. Tank 1	7,190.6	Gallons
-----------	---------	---------

A13. High Alarm OR	Alarm OR	ON
A14. High Alarm AND	Alarm AND	OFF
RY-1. Relay 1		ON

Simulate - A1. High Alarm 1

Real - + Keypad Ok

Press the **+** key to turn on the alarm; note that alarm 13 and relay 1 also turned on. Press **Ok** key to maintain simulation or press **Real** to cancel simulation.

View Inputs

The *View Inputs* menu displays the values and status of all the inputs and the details of the associated channels. Input simulation is also available in the input details.

- Input # and tag
- mA input value
- Pulse input frequency
- Digital input status
- Modbus input value
- Associated channel(s)
- Input simulation

CAUTION

Manual control and simulation states are not saved on power cycle. On power up the controller initializes to the actual process conditions.

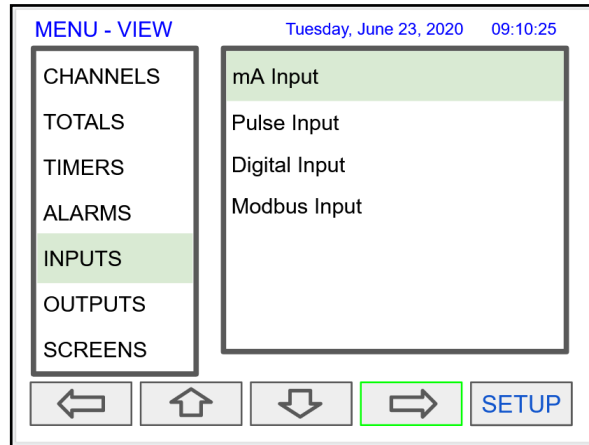

Press the **Right Arrow** key to select the mA Input.

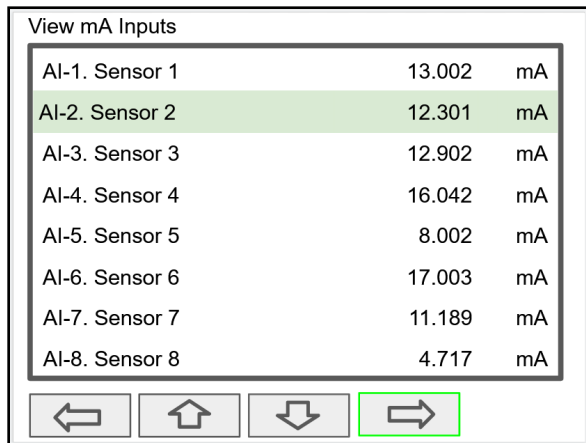

Press the **Right Arrow** key to view the mA Input details.

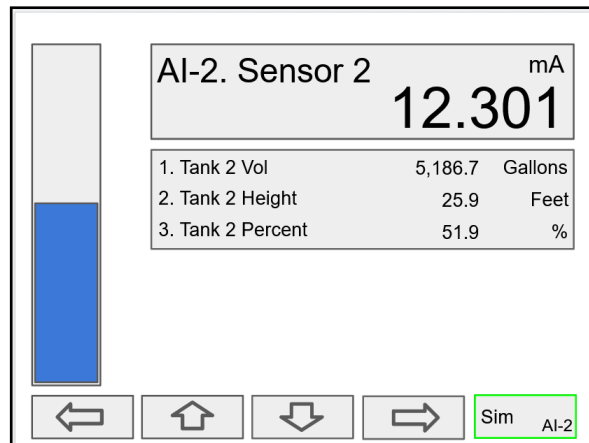

The above screen shows the Analog Input 2 details and the associated channels.

Simulate mA Input

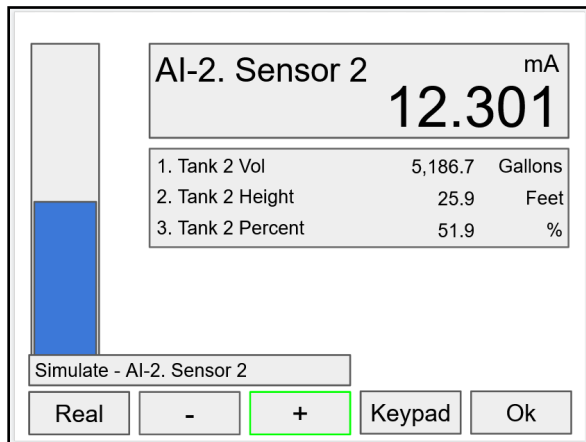

Use the **+ / -** keys to ramp up and down or use the keypad to jump to any value within the range. Press the **Ok** key to maintain the input in simulation mode.

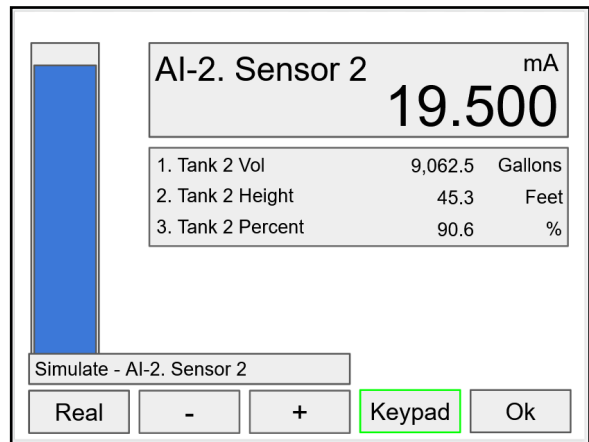

All the parameters associated with the simulated input follow the simulated value. Press the **Real** key to cancel simulation and return to the actual sensor signal.

View Outputs

The *View Outputs* menu displays the values and status of all the outputs and the details of the associated channels.

- Output # and tag
- mA output value
- Relay output status
- Digital output status
- Number of cycles & runtime
- Associated input
- Manual control of relays
- Manual control of 4-20 mA outputs

CAUTION

Manual control and simulation states are not saved on power cycle. On power up the controller initializes to the actual process conditions.

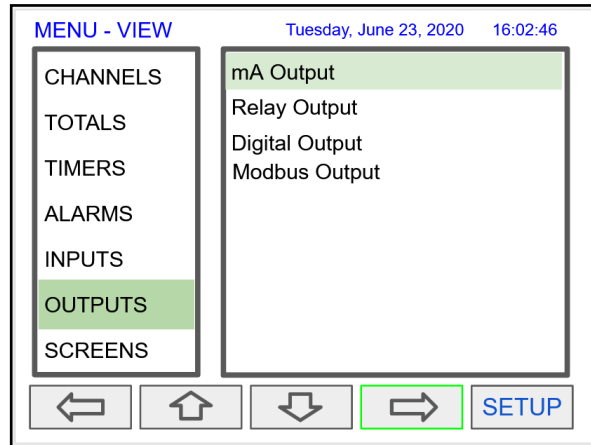

Press the **Right Arrow** key to select the mA Output.

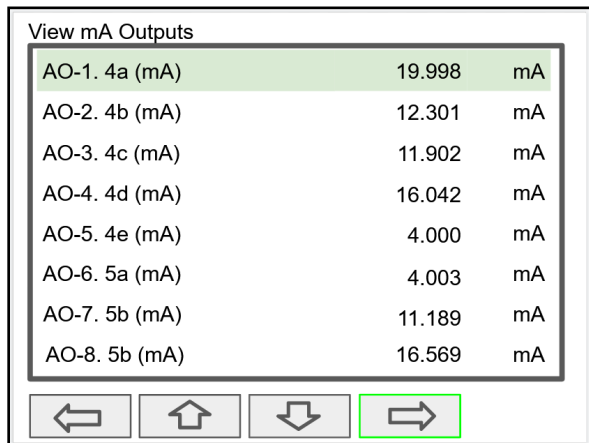

Press the **Right Arrow** key to view the mA Output details.

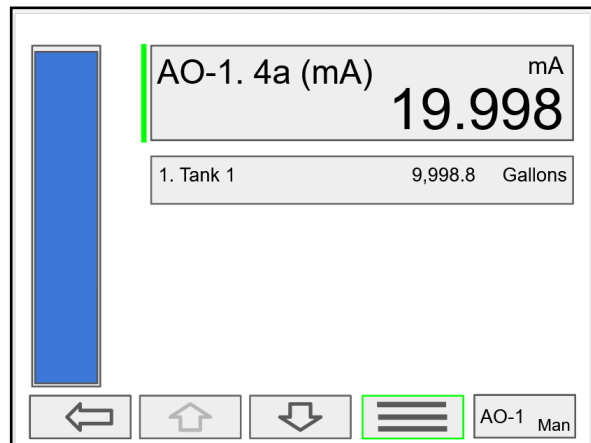

Press the **3-Bar** key to access Analog Output controls. Manual control, hold current value, return to automatic.

Manual Control of 4-20 mA Output

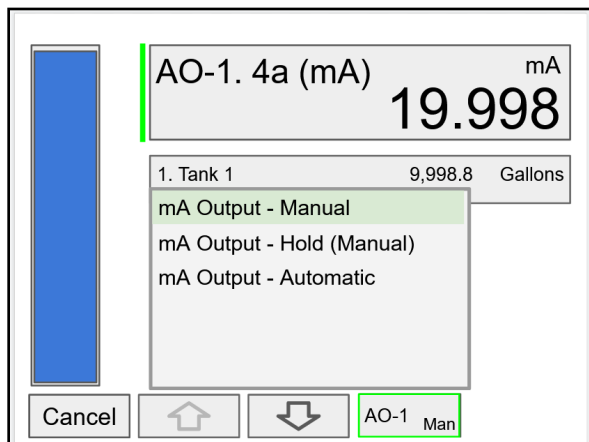

Select **Manual** to control the analog output manually; select **Automatic** to exit manual control.

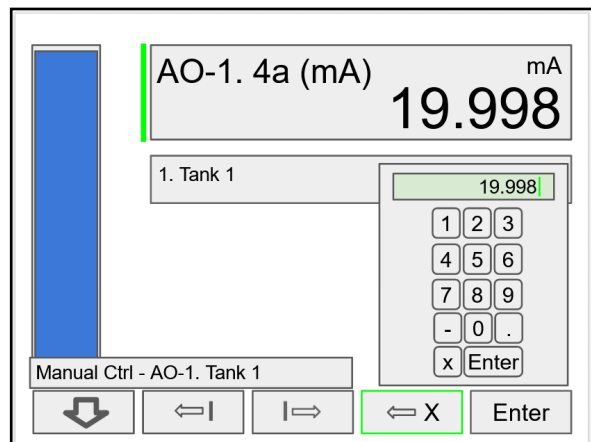

Use the keypad to enter a value for the analog output or use the + / - keys to ramp up and down in small steps.

View Relays

The *View Relays* menu allows the user to view the details for all the relays. The F4 key can be used to turn on and off the selected relay (momentarily).

Press the **Right Arrow** key to view the relay details.

- Relay # and tag
- Status
- Runtime
- Number of Cycles
- Reset relay runtime & cycles count
- Parameters associated with the relay
- Other relays used in pump alternation
- Manual control of relays

CAUTION

Manual control and simulation states are not saved on power cycle.

View Relays

RY-1. Pump # 1	ON
RY-2. Pump #2	ON
RY-3. Pump #3	OFF
RY-4. Pump #4	ON
RY-5. Pump #5	OFF
RY-6. Pump #6	OFF
RY-7. Pump #7	ON
RY-8. Pump #8	ON

Navigation: Left Arrow, Home, Down Arrow, Right Arrow (highlighted), RY-1 OFF

RY-1. Pump #1

Runtime: 36:10:58
Cycles: 300

ON

1. Tank 1	9,998.5	Gallons
-----------	---------	---------

RY-2. Pump #2 ON

Navigation: Left Arrow, Home, Down Arrow, Menu (highlighted), Rset RY-1

RY-1. Pump #1

Runtime: 36:10:58
Cycles: 300

ON

1. Tank 1	9,998.5	Gallons
-----------	---------	---------

Relay - Rset Info (Confirm)

Relay - Manual ON

Relay - Manual OFF (highlighted)

Relay - Automatic

Navigation: Cancel, Home, Down Arrow, RY-1 OFF (highlighted)

Press the **Manual OFF** to turn off relay 1; Pump #1 will go off and remain off until the relay 1 is put back in automatic mode.

An Alert! message is displayed in place of the Menu key anytime an item is in manual control or simulation mode.

View Alert Messages

WEST END STORAGE

1. Tank 1	GALLONS	13,041.3
2. Tank 2	GALLONS	15,652.1
3. Tank 3	GALLONS	16,956.8
4. Tank 4	GALLONS	19,566.2

Alert! (highlighted)

Navigation: Home, Down Arrow, Scan, Ack All

If Alerts are enabled for alarms, the **Menu** key displays a flashing Alert! message on red background.

Simulated parameters and manual control outputs, automatically generate alert messages displayed on a yellow background.

Alerts!

Alarm: A1. High Alarm 1

Simulated: AI-2. Sensor 2

Manual: RY-1. Pump #1 (highlighted)

Manual: AO-3. Tank 3

Navigation: Left Arrow, Home, Down Arrow, Right Arrow, Auto (highlighted)

The Alerts! Screen allows the user to acknowledge alarms, return outputs to automatic mode, and navigate to any of the listed items to view the details.

View Digital Outputs

The *View Digital Outputs* screen displays the status of the digital outputs and shows the association with the parameters used to drive the outputs.

DO-1. Digital Output 1	OFF
DO-2. Digital Output 2	ON
DO-3. Digital Output 3	OFF
DO-4. Digital Output 4	OFF



View Modbus Outputs

The *View Modbus Outputs* screen displays the Modbus outputs set up by the user; it shows the register number and the parameter used to generate each output.

MO-1. Sensor 1 mA	44401, 44402	10.989
MO-2. Sensor 2 mA	44403, 44404	12.005
MO-3. Sensor 3 mA	44405, 44406	15.892
MO-4. Sensor 4 mA	44407, 44408	19.589



⚠ CAUTION

Manual control and simulation states are not saved on power cycle. On power up the controller initializes to the actual process conditions.

View Screens

With the View Screens menu, the user can go to any available screen and view the details. The screens can be scanned continuously or can be stopped to stay on a selected screen at anytime.

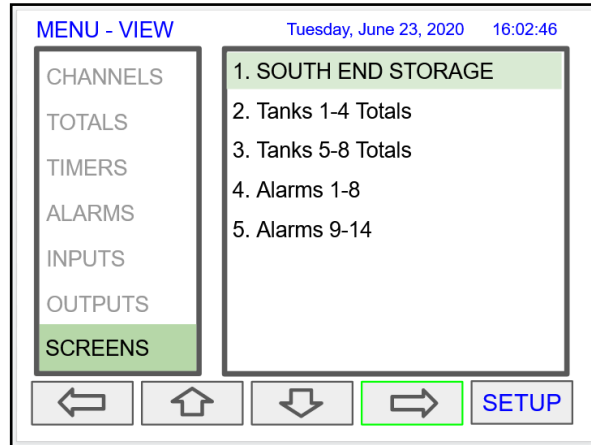

Press the **Right Arrow** key to view details of the the selected view screen.

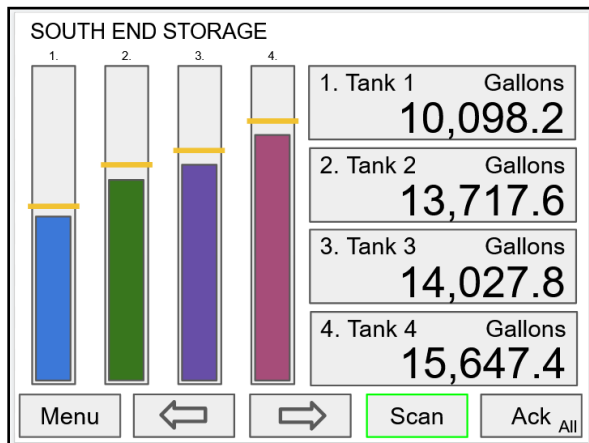

Press the **Scan** key to have all available screens continue to scan.

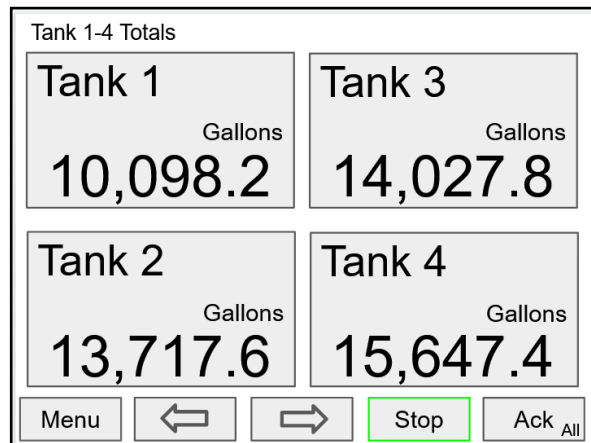

Press the **Stop** key to have all available screens stop scanning and stay on the current screen.

Operation

Viewing Screens

The controller displays various screens with bargraphs, numerical values, and relay status throughout operation, according to the user-selected setup. There are two basic modes of operation: Automatic scan or manual scan. The controller initializes in automatic scan mode. Press Stop key to stop the automatic scan and use the Left or Right Arrow keys (Previous or Next) to navigate through the various screens. Press the Scan key to resume automatic scanning.

The bargraphs are optional, they are enabled or disabled during *Screens* setup. The scaling of the bargraph is done during the setup of each channel and it can be different than the channel scaling values.

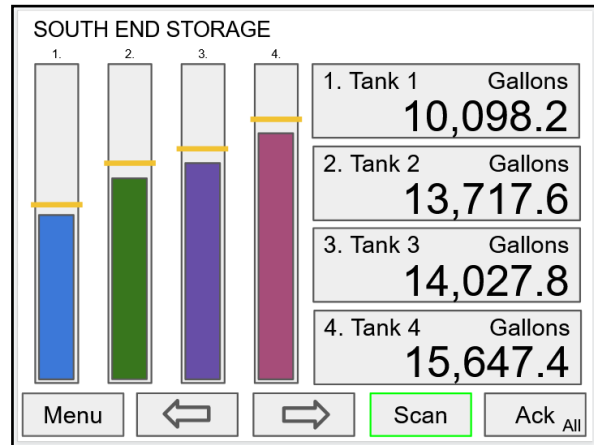

Individual Channel View

To view the details of any channel, press the Menu key and then press Right Arrow key to view the channels. Select the channel of interest. Navigate through the different items using the navigation keys. A green bar indicates the selected item, press the Right Arrow key to step into and see more details about the inputs and outputs related to the channel in view.

If applicable, alarms may be acknowledged, and totals may be reset from these screens. Simulation and manual control are also available on the *View* screens.

Low & High Alarm Indication

The alarm set points are indicated by a line at the corresponding value on the bargraph. Color selection is done in the *Setup - Alarm* menu or in the *System - Display* menu.

Active High Alarm: Indicated by horizontal and vertical lines. The bottom of the vertical line is the reset point of the high alarm. The high alarm is indicated on the left side of the bargraph.

Active Low Alarm: Indicated by horizontal and vertical lines. The top of the vertical line is the reset point of the low alarm. The low alarm is indicated on the right side of the bargraph.

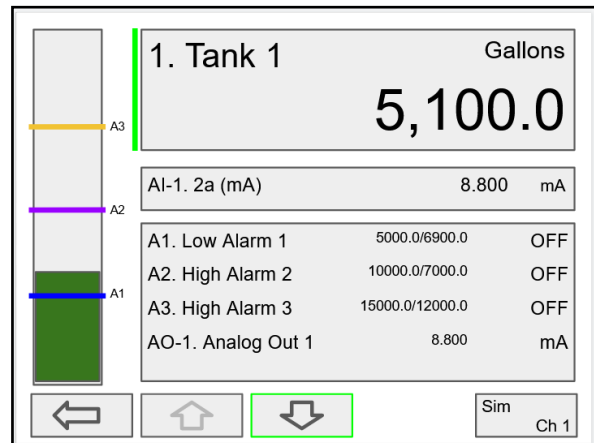

Alarm set points are indicated by horizontal lines.

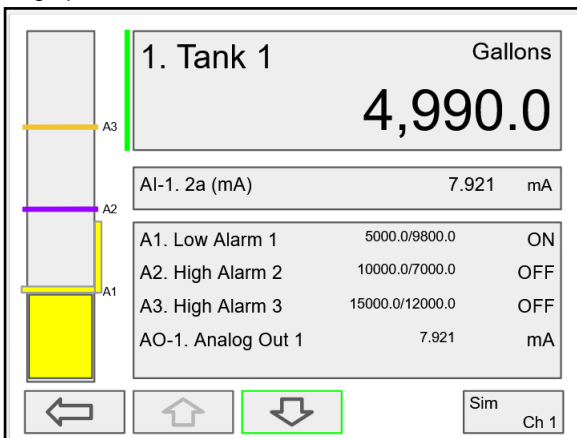

Low alarm indication

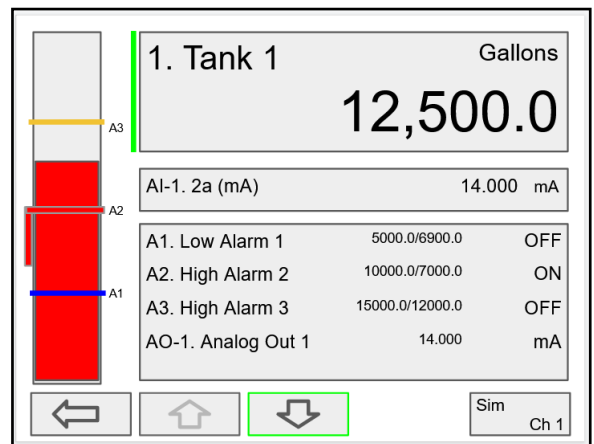

High alarm indication

Multicolor Bargraph Indication

The bargraph may be configured to show different colors depending on the value of the process variable. The following example illustrates the use of colors:

Process Variable %	Bargraph Color	Set Pt	Reset Pt
< 25	Green	N/A	N/A
> 25	Yellow	25.0	25.0
> 50	Amber	50.0	50.0
> 75	Red	75.0	75.0

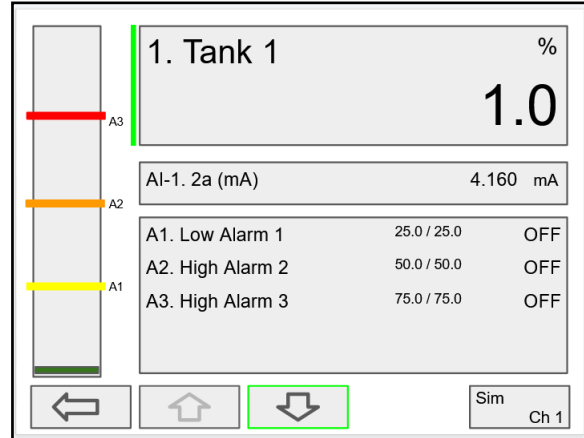

Color changes above the set point for each alarm

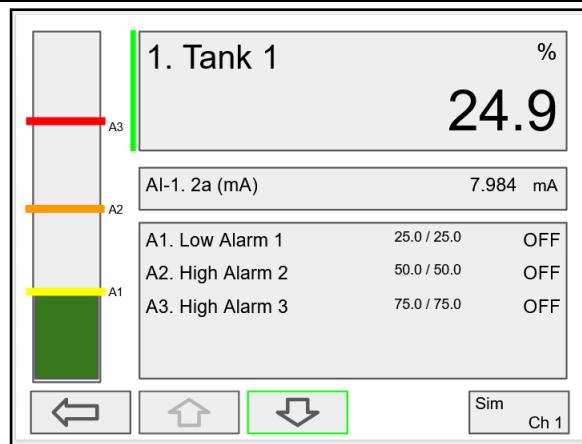

The bargraph shows green below the the first set point

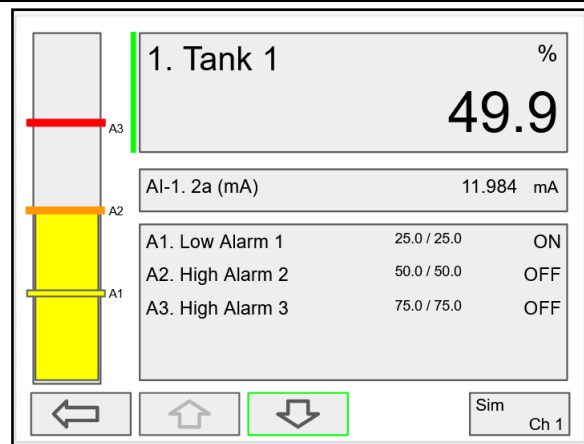

The bargraph changes to yellow above set point 1

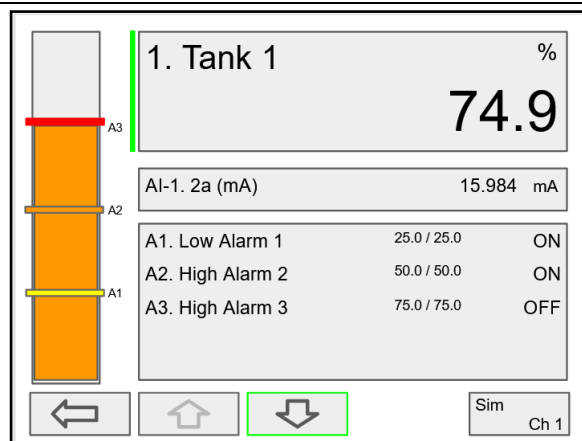

The bargraph changes to orange above set point 2

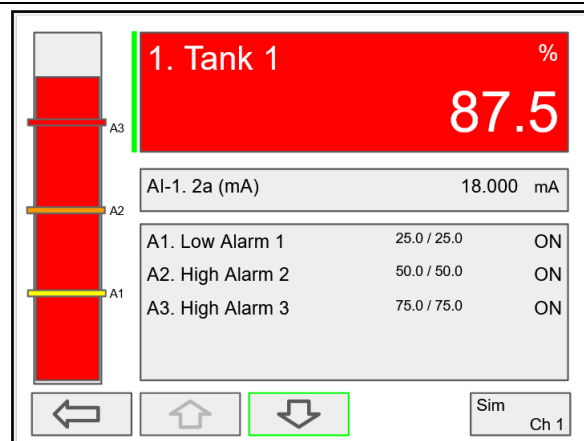

The bargraph changes to red above set point 3.

The panel for the value can also be configured to change colors at the specified levels.

Modbus® RTU Serial Communication

The controller is equipped with serial communication capability as a standard feature. Baud Rate, Parity, Slave ID (Address) and Transmit Delay are entered in the *System* menu, which appears in the main *Setup* menu. The baud rate and parity selected must match the settings for all other devices on the network. The Slave ID must be unique, so it will not interfere with other devices. The controller supports the following Modbus functions:

Command	Name	Description
01	Read Coils (0x)	Read coil value
03	Read Holding Register (4x)	Read multiple bytes from holding registers.
04	Read Input Register (3x)	Read multiple bytes from input registers.
05	Write Single Coil (Bit)	Set single coil value control
15	Write Multiple Coils (Bits)	Set multiple coil value control
06	Write Single Register	Set single value into specified holding register.
16	Write Multiple Registers	Set multiple values into specified holding registers.

The multi-channel controller can also work as a “Modbus Display/Controller” by writing the desired value to the selected Modbus input (MB-1 to MB-199). The Modbus input can be used the same way a 4-20 mA input is used; it can be brought into a channel to be displayed and generate alarms to control relays, generate 4-20 mA outputs, and Modbus outputs (MO-1 to MO-64).

Modbus Register Tables

Table 1. Default Register Numbers / Addresses

Reg. Number	Reg. Address	Description	Data Type	Function Codes	R/W
40001	0	Channel (1) Value	Float	03, 04	R
40003	2	Channel (2) Value	Float	03, 04	R
40005	4	Channel (3) Value	Float	03, 04	R
40007	6	Channel (4) Value	Float	03, 04	R
40009	8	Channel (5) Value	Float	03, 04	R
40011	10	Channel (6) Value	Float	03, 04	R
40013	12	Channel (7) Value	Float	03, 04	R
40015	14	Channel (8) Value	Float	03, 04	R
40017	16	Total (1) Value	Float	03, 04	R
40019	18	Total (2) Value	Float	03, 04	R
40021	20	Total (3) Value	Float	03, 04	R
40023	22	Total (4) Value	Float	03, 04	R
40025	24	Timer (1) Value	Float	03, 04	R
40027	26	Timer (2) Value	Float	03, 04	R
40029	28	Timer (3) Value	Float	03, 04	R
40031	30	Timer (4) Value	Float	03, 04	R
40033	32	Alarm (1) Status*	Short	03, 04	R
40034	33	Alarm (2) Status*	Short	03, 04	R
40035	34	Alarm (3) Status*	Short	03, 04	R
40036	35	Alarm (4) Status*	Short	03, 04	R
40037	36	Alarm (5) Status*	Short	03, 04	R
40038	37	Alarm (6) Status*	Short	03, 04	R
40039	38	Alarm (7) Status*	Short	03, 04	R
40040	39	Alarm (8) Status*	Short	03, 04	R

*Alarm Status: 0: Off, 1: On, 2: On & Acknowledged

The table above contains some predefined registers and data types used.

The following table contains the definitions of all accessible registers with their corresponding data type.

Table 2. Device Tag, Date & Time, Info

Reg. Number	Reg. Address	Description	Data Type	Function Codes	R/W	Comments
40041 - 40056	40-55	Device Tag	String (32 char)	03, 04	R	Null terminating string Write 00 for the last char
		RTC Date & Time				
40061	60	Year	Short	03, 04	R	20 = 2020
40062	61	Month	Short	03, 04	R	
40063	62	Day	Short	03, 04	R	
40064	63	Hour	Short	03, 04	R	
40065	64	Minute	Short	03, 04	R	
40066	65	Second	Short	03, 04	R	
40073	72	SFT No.	Short	03, 04	R	
40074	73	SFT Version	Short	03, 04	R	
40081	80	Program Id	Short	06, 16	W	Program is executed when Program Id is written. Program parameters may be written either before or with the Program Id. See <i>Table 4.</i> for details.
40082 - 40099	81 - 98	Program Parameters (x18)	Various	06, 16	W	

PV's Register Numbers & Addresses

The PV's register numbers and register addresses are calculated based on the formulas provided below. The values are available in various data types. Examples of register addresses (base 0) are provided on the right column. Register numbers refer to PLC Addresses (base 1). Function Code 03 Read Holding Registers (4x) are shown on this table and used throughout the system; other functions are also supported as indicated in the Function column.

The Modbus input registers can be configured under the *Setup – Inputs – Modbus* menu and the Modbus output registers can be mapped under the *Setup – Outputs – Modbus* menu; this allows assigning any parameter to the Modbus output registers and selecting the data type for input and output registers.

Table 3. PV's Register Numbers & Register Addresses

Reg. Number	Reg. Address	Channel (N = 1 ... 99)	Data Type	Bits	Function	R/W	Reg. Address Examples
00101 + (N - 1)	100 + (N - 1)	Channel (N) Value	Bit	1	01, 02	R	Ch1 = 100
40101 + (N - 1)	100 + (N - 1)	Channel (N) Value	Short	16	03, 04	R	Ch1 = 100
40201 + 2(N - 1)	200 + 2(N - 1)	Channel (N) Value	Long	32	03, 04	R	Ch2 = 202
40401 + 2(N - 1)	400 + 2(N - 1)	Channel (N) Value	Float	32	03, 04	R	Ch3 = 404
40601 + 4(N - 1)	600 + 4(N - 1)	Channel (N) Value	Double	64	03, 04	R	Ch4 = 612
41001 + 4(N - 1)	1000 + 4(N - 1)	Channel (N) Value	Long Long	64	03, 04	R	Ch99 = 1392
		Total (N = 1 ... 32)					
42101 + (N - 1)	2100 + (N - 1)	Total (N) Value	Short	16	03, 04	R	Total 1 = 2100
42201 + 2(N - 1)	2200 + 2(N - 1)	Total (N) Value	Long	32	03, 04	R	Total 1 = 2202
42301 + 2(N - 1)	2300 + 2(N - 1)	Total (N) Value	Float	32	03, 04	R	Total 1 = 2302
42401 + 4(N - 1)	2400 + 4(N - 1)	Total (N) Value	Double	64	03, 04	R	Total 1 = 2404
42601 + 4(N - 1)	2600 + 4(N - 1)	Total (N) Value	Long Long	64	03, 04	R	Total 32 = 2724
		Timer (N = 1 ... 32)					
43101 + (N - 1)	3100 + (N - 1)	Timer (N) Value (sec)	Short	16	03, 04	R	Timer 1 = 3100
43201 + 2(N - 1)	3200 + 2(N - 1)	Timer (N) Value (sec)	Long	32	03, 04	R	Timer 1 = 3202
43301 + 2(N - 1)	3300 + 2(N - 1)	Timer (N) Value (sec)	Float	32	03, 04	R	Timer 1 = 3302
43401 + 4(N - 1)	3400 + 4(N - 1)	Timer (N) Value (sec)	Double	64	03, 04	R	Timer 32 = 3524
		Alarm (N = 1 ... 64)		64			
43601 + (N - 1)	3600 + (N - 1)	Alarm (N) Status	Short		03, 04	R	0: Off, 1: On, 2: On & Ack
		Modbus Output (N = 1 ... 64)					
04101 + (N - 1)	4100 + (N - 1)	Modbus Output (N) Value	Bit (0 or 1)	1	01, 02	R	MO-1 = 4100
44101 + (N - 1)	4100 + (N - 1)	Modbus Output (N) Value	Short	16	03, 04	R	MO-1 = 4100
44201 + 2(N - 1)	4200 + 2(N - 1)	Modbus Output (N) Value	Long	32	03, 04	R	MO-1 = 4202
44401 + 2(N - 1)	4400 + 2(N - 1)	Modbus Output (N) Value	Float	32	03, 04	R	MO-1 = 4402
44601 + 4(N - 1)	4600 + 4(N - 1)	Modbus Output (N) Value	Double	64	03, 04	R	MO-1 = 4604
45001 + 4(N - 1)	5000 + 4(N - 1)	Modbus Output (N) Value	Long Long	64	03, 04	R	MO-64 = 5252
		Modbus Input (N = 1 ... 199)					
06101 + (N - 1)	6100 + (N - 1)	Modbus Input (N) Value	Bit (0 or 1)	1	01, 02, 05, 15	R/W	MB-1 = 6100
46101 + (N - 1)	6100 + (N - 1)	Modbus Input (N) Value	Short	16	03, 04, 06, 16	R/W	MB-1 = 6100
46301 + 2(N - 1)	6300 + 2(N - 1)	Modbus Input (N) Value	Long	32	03, 04, 16	R/W	MB-1 = 6302
46701 + 2(N - 1)	6700 + 2(N - 1)	Modbus Input (N) Value	Float	32	03, 04, 16	R/W	MB-1 = 6702
47101 + 4(N - 1)	7100 + 4(N - 1)	Modbus Input (N) Value	Double	64	03, 04, 16	R/W	MB-1 = 7104
47901 + 4(N - 1)	7900 + 4(N - 1)	Modbus Input (N) Value	Long Long	64	03, 04, 16	R/W	MB-199 = 8692

Modbus Write Protection

The Modbus write passcode protection can be enabled in the *System – Modbus* menu. This protection prevents writing to the registers, unless the unlock code 1 is sent to register 81 followed by the passcode sent to register 82. The protection is automatically restored after 30 seconds of Modbus – write inactivity. See page 53 for details.

Table 4. Program Parameters for Special Functions

Reg. Number	Reg. Address	Description	Data Type	Function	R/W	Program Code	Comments
40081	80	Program Id					Program is executed when Program Id is written.
40082 - 40099	81 - 98	Program Parameters (x8)					Program parameters may be written either before or with the Program Code.
40081	80	Unlock Modbus Passcode	Short	06, 16	W	1	Locks again after 30 seconds.
40082	81	Modbus Passcode	Short	06, 16	W		Cleared upon execution. Must be re-written with each Unlock.
40081	80	Set RTC Date & Time	Short	06, 16	W	6	
40082	81	Year	Short	06, 16	W		0..99
40083	82	Month	Short	06, 16	W		1..12
40084	83	Day	Short	06, 16	W		1..31
40085	84	Hour	Short	06, 16	W		0..23 Program Code plus parameters ending at Hour will set Minute and Second to zero.
40086	85	Minute	Short	06, 16	W		0..59 Program Code plus parameters ending at Minute will set Second to zero
40087	86	Second	Short	06, 16	W		0..59
40081	80	Channel - Get Tag	Short	06, 16	W	11	
40082	81	Channel (N)	Short	06, 16	W		
40083 - 40090	82 - 89	Tag	String (16 char)	03, 04	R		Null terminated string.
40081	80	Reset Channel	Short	06, 16	W	12	
40082	81	Channel (N)	Short	06, 16	W		Program Code with only single parameter will ignore remaining parameters.
40083	82	Thru Channel (N)	Short	06, 16	W		0 to ignore
40081	80	Set Channel	Short	06, 16	W	13	Tare, Capture, Switch
40082	81	Channel (N)	Short	06, 16	W		Program Code with only single parameter will ignore remaining parameters.
40083	82	Thru Channel (N)	Short	06, 16	W		0 to ignore
40081	80	Total - Get Tag	Short	06, 16	W	27	
40082	81	Total (N)	Short	06, 16	W		
40083 - 40090	82 - 89	Tag	String (16 char)	03, 04	R		Null terminated string.

Reg. Number	Reg. Address	Description	Data Type	Function	R/W	Program Code	Comments
40081	80	Reset Total	Short	06, 16	W	28	
40082	81	Total (N)	Short	06, 16	W		Program Code with only single parameter will ignore remaining parameters.
40083	82	Thru Total (N)	Short	06, 16	W		0 to ignore
40081	80	Timer - Get Tag	Short	06, 16	W	41	
40082	81	Timer (N)	Short	06, 16	W		
40083 - 40090	82 - 89	Tag	String (16 char)	03, 04	R		Null terminated string.
40081	80	Timer	Short	06, 16	W	42	
40082	81	Timer (N) - Reset	Short	06, 16	W		0 to not Reset Program Code with parameters will ignore remaining parameters. Program Code with single Timer (N) will Reset without Start or Stop.
40083	82	Timer (N) - Start	Short	06, 16	W		0 to not Start Program Code with two Timer (N) registers will Reset and Start; and ignore Stop.
40084	83	Timer (N) - Stop	Short	06, 16	W		0 to not Stop
40085	84	Thru Timer (N) - Reset	Short	06, 16	W		0 to ignore
40086	85	Thru Timer (N) - Start	Short	06, 16	W		0 to ignore
40087	86	Thru Timer (N) - Stop	Short	06, 16	W		0 to ignore
40081	80	Alarm - Get Tag	Short	06, 16	W	55	
40082	81	Alarm (N)	Short	06, 16	W		
40083 - 40090	82 - 89	Tag	String (16 char)	03, 04	R		Null terminated string.
40081	80	Reset Alarm	Short	06, 16	W	56	
40082	81	Alarm (N)	Short	06, 16	W		Program Code with only single parameter will ignore remaining parameters.
40083	82	Thru Alarm (N)	Short	06, 16	W		0 to ignore
40081	80	Ack Alarm	Short	06, 16	W	57	
40082	81	Alarm (N)	Short	06, 16	W		Program Code with only single parameter will ignore remaining parameters.
40083	82	Thru Alarm (N)	Short	06, 16	W		0 to ignore
40081	80	Alarm - Start	Short	06, 16	W	58	Interval alarms
40082	81	Alarm (N)	Short	06, 16	W		Program Code with only single parameter will ignore remaining parameters.
40083	82	Thru Alarm (N)	Short	06, 16	W		0 to ignore

Reg. Number	Reg. Address	Description	Data Type	Function	R/W	Program Code	Comments
40081	80	Alarm - Stop	Short	06, 16	W	59	Interval alarms
40082	81	Alarm (N)	Short	06, 16	W		Program Code with only single parameter will ignore remaining parameters.
40083	82	Thru Alarm (N)	Short	06, 16	W		0 to ignore
40081	80	Alarm - Restart	Short	06, 16	W	60	Interval alarms
40082	81	Alarm (N)	Short	06, 16	W		Program Code with only single parameter will ignore remaining parameters.
40083	82	Thru Alarm (N)	Short	06, 16	W		0 to ignore
40081	80	Horn - Silence	Short	06, 16	W	73	Horn Off until new trigger.
40081	80	Horn - Snooze	Short	06, 16	W	74	Horn Off until new trigger, or until Seconds.
40082	81	Seconds	Short	06, 16	W		
40081	80	Horn - Test	Short	06, 16	W	75	Horn Off until Seconds.
40082	81	Seconds	Short	06, 16	W		
40081	80	Relay - Get Tag	Short	06, 16	W	82	
40082	81	Relay (N)	Short	06, 16	W		
40083 - 40090	82 - 89	Tag	String (16 char)	03, 04	R		Null terminated string.
40081	80	Relay - Reset Info	Short	06, 16	W	83	
40082	81	Relay (N)	Short	06, 16	W		Program Code with only single parameter will ignore remaining parameters.
40083	82	Thru Relay (N)	Short	06, 16	W		0 to ignore
40081	80	Relay - Automatic	Short	06, 16	W	84	
40082	81	Relay (N)	Short	06, 16	W		Program Code with only single parameter will ignore remaining parameters.
40083	82	Thru Relay (N)	Short	06, 16	W		0 to ignore
40081	80	Relay - Manual ON	Short	06, 16	W	85	
40082	81	Relay (N)	Short	06, 16	W		Program Code with only single parameter will ignore remaining parameters.
40083	82	Thru Relay (N)	Short	06, 16	W		0 to ignore
40081	80	Relay - Manual OFF	Short	06, 16	W	86	
40082	81	Relay (N)	Short	06, 16	W		Program Code with only single parameter will ignore remaining parameters.
40083	82	Thru Relay (N)	Short	06, 16	W		0 to ignore

Reg. Number	Reg. Address	Description	Data Type	Function	R/W	Program Code	Comments
40081	80	Relay - Manual Hold	Short	06, 16	W	87	
40082	81	Relay (N)	Short	06, 16	W		Program Code with only single parameter will ignore remaining parameters.
40083	82	Thru Relay (N)	Short	06, 16	W		0 to ignore
40081	80	mA Out - Get Tag	Short	06, 16	W	92	
40082	81	mA Out (N)	Short	06, 16	W		
40083 - 40090	82 - 89	Tag	String (16 char)	03, 04	R		Null terminated string.
40081	80	mA Out - Automatic	Short	06, 16	W	93	
40082	81	mA Out (N)	Short	06, 16	W		Program Code with only single parameter will ignore remaining parameters.
40083	82	Thru mA Out (N)	Short	06, 16	W		0 to ignore
40081	80	mA Out - Manual	Short	06, 16	W	94	
40082	81	mA Out (N)	Short	06, 16	W		
40083 - 40084		value (N)	float	06, 16	W		
40081	80	mA Out - Manual	Short	06, 16	W	95	
40082	81	mA Out (N)	Short	06, 16	W		
40083	82	value x 100 (N)	Short	06, 16	W		For 4.00 mA, write 400. For 16.5 mA, write 1650.
40081	80	mA Out - Manual Hold	Short	06, 16	W	96	
40082	81	mA Out (N)	Short	06, 16	W		Program Code with only single parameter will ignore remaining parameters.
40083	82	Thru mA Out (N)	Short	06, 16	W		0 to ignore

Relay Control Using Modbus

To control the relays via Modbus, use the Write Single Coil command [command code 05] or Write Multiple Coils [command code 15] and send either the “ON” or “OFF” to the Modbus input associated with the target relay.

Setup Example #1

Follow this example to set up Modbus Input to control a relay and configure the system to display messages related to the status of the device being controlled, in this case a pump.

Setup – MB-1.

1. Tag: Modbus Input 1
2. Type: Bit – Logic (Reg. No. 06101 or Reg. Address 06100)
3. Units: Logic = PUMP ON / PUMP OFF
4. Break: Default = OFF

Setup – RY-1.

1. Tag: Relay 1
2. Input: MB-1. Modbus Input 1

Setup – Create Screen

1. Title: Pumps
2. MB-1. Modbus Input 1
3. RY-1. Relay 1
4. F3: Assign to Force On RY-1
5. F4: Assign to Force Off RY-1

Operation: Write “1” to Reg. 06101 to turn relay 1 On; write “0” to turn relay 1 Off.

Setup Example #2

Follow this example to control the relays directly from Modbus using special program functions. You can control one or all relays with one command.

40081	80	Relay - Automatic	Short	06, 16	W	84	
40082	81	Relay (N)	Short	06, 16	W		Program Code with only single parameter will ignore remaining parameters.
40083	82	Thru Relay (N)	Short	06, 16	W		0 to ignore
40081	80	Relay - Manual ON	Short	06, 16	W	85	
40082	81	Relay (N)	Short	06, 16	W		Program Code with only single parameter will ignore remaining parameters.
40083	82	Thru Relay (N)	Short	06, 16	W		0 to ignore
40081	80	Relay - Manual OFF	Short	06, 16	W	86	
40082	81	Relay (N)	Short	06, 16	W		Program Code with only single parameter will ignore remaining parameters.
40083	82	Thru Relay (N)	Short	06, 16	W		0 to ignore

- 1) To manually turn on relay 1 write:
 - a. Reg. 40081: 85
 - b. Reg. 40082: 1
 - c. Reg. 40083: 0 (last relay, if more than one)
- 2) To manually turn off relay 1 write:
 - a. Reg. 40081: 86
 - b. Reg. 40082: 1
 - c. Reg. 40083: 0 (last relay, if more than one)
- 3) To return relays to normal operation write commands for automatic control.
 - a. Reg. 40081: 84

Troubleshooting Tips

Symptom	Check/Action
No display or only backlight is visible, but outputs still function normally.	<ol style="list-style-type: none"> 1. Ambient temperature is below -40°C and affects LCD visibility. 2. Grounding is inadequate or not connected. Check earth ground continuity.
“BREAK” is displayed	Check the 4-20 mA input; if less than the break value (e.g. 0.01 mA), it displays BREAK. This can be changed in the Input menu.
Display response seems slower than normal	Ambient temperature is too cold: Consider installing a heater with the instrument.
Display reading is unstable, it fluctuates too much	<ol style="list-style-type: none"> 1. Check signal source stability 2. Increase filter value 3. Decrease the display refresh rate (increase time)
mA input not responding to signal changes (value frozen)	<ol style="list-style-type: none"> 1. Cycle the power or 2. Go to setup mA input and disable input channel, then enable the input channel 3. Check that back cover is fully seated, and all I/O cards are tightly fixed in place.
Display locks up or the instrument does not respond at all	Cycle the power to reboot the microprocessor.
Settings reprogrammed, but instrument behavior remains as previously programmed	Cycle the power to reboot the microprocessor.
Relay and status do not respond to signal	<ol style="list-style-type: none"> 1. Check if relays are in manual control mode. 2. Check Setup menu alarm set and reset points.
Writing to Modbus Input register failed	Check register number or register address being used <ol style="list-style-type: none"> 1. If using PLC address (Base 1) use register number (e.g. 46701) 2. If using Base 0 address, use register address (e.g. 6700)
Controller does not communicate with another device.	Check baud rates and parity settings. Make sure all serial devices have matching parameters.
Other symptoms not described above	Call Technical Support for assistance.

Model:	
Serial Number:	
System Password:	

Contact Precision Digital

Technical Support

Call: (800) 610-5239 or (508) 655-7300

Fax: (508) 655-8990

Email: support@predig.com

Sales Support

Call: (800) 343-1001 or (508) 655-7300

Fax: (508) 655-8990

Email: sales@predig.com

Place Orders

Email: orders@predig.com

For the latest version of this manual please visit

www.predig.com

PRECISION DIGITAL CORPORATION

233 South Street • Hopkinton MA 01748 USA

Tel (800) 343-1001 • Fax (508) 655-8990

www.predig.com

