

PD9000 ConsoliDator+ Multivariable Controller

Data Sheet



PD9000 Installed in
PDA2909 Enclosure



PD9000 Panel Mount
Multivariable Controller



UL & C-UL Listed for Div 2
Hazardous (nonincendive) and
Ordinary Location Installations.
Select models; see Ordering
Information for complete details.

- NEMA 4X Panel Mount Multivariable Controller
- Convenient Display, Control, & Alarm of Multiple 4-20 mA, Temperature, Pulse, & Modbus Inputs
- Numeric & Bargraph Color Display (320 x 240 pixels) 5.7" (145 mm)
- Sunlight Readable Display, White Backlight; UL/C-UL Listed Sun Hood Option Available
- Isolated 24 VDC Transmitter Supplies 200 mA / Analog Input: 1,600 mA Max
- 99 Channels, 32 Totalizers, 30 Timers, & 199 Modbus Inputs
- 64 High & Low Alarms, Combine Multiple Alarms Into Logic AND & OR Alarms
- Simulation & Manual Control Modes for Testing and Setup
- Modular Design for Inputs & Outputs Flexibility
- Up to (28) Inputs; Isolated 4-20 mA, Pulse, or Temperature (Thermocouple or RTD)
- Up to (25) 10 Amp Form C Relays (With Eight Analog or Pulse Inputs)
- Up to (25) Isolated 4-20 mA Outputs (With Eight Analog or Pulse Inputs)
- Operating Temperature Range: -25°C to 55°C (-13 to 131°F)
- Print Critical Data from ConsoliDator+ with Printer Card
- Pulse, Analog, & Modbus Input Flow Rate / Total / Grand Total Capability
- 50-Point Linearization, Square Root, and Exponent for Open Channel Flow
- Round Horizontal Tank Volume Calculation; Just Enter Diameter & Length
- Open Channel Flow Math Formulas for Weirs & Flumes
- Multi-Pump Alternation with On-Off Multi-Setpoint Control and Lead-Lag Control
- HOA Switch Functions for Controlling Pumps by Setting Relay Actions for Automatic, Manual, or On/Off Modes
- Advanced Batch Control Features with Ticket Printing Capabilities
- Programmable Displays, Function Keys & Digital Inputs (Five Standard) and Optional 15-Digital Inputs Card Available
- Math Functions: Sum, Diff, Average, Multiply, Divide, % Efficiency, & More
- Modbus Client (Master) & Snooper / Server with 99 Programmable Outputs
- Direct Modbus PV Inputs – Snooper / Server Mode
- RS-485 Serial Communication with Modbus RTU / ASCII & Ethernet TCP/IP
- USB Data Logger Feature: Up to 8 Log Files with up to 12 Parameters Each
- Input Power Options: 90-264 VAC or 24 VDC
- (20) Screens with up to Eight PVs Each
- ConsoliDator+ Configuration Software
- Type 4X, IP66 Front – Field Enclosures Available
- Auto-Tune PID Control for Multiple Control Loops with Analog, Digital, or Relay Outputs
- 3-Year Warranty



TABLE OF CONTENTS

- OVERVIEW 3
- SCREENS. 3
- APPLICATIONS 5
- PRINTER CARD OPTION. 22
- INPUTS & OUTPUTS 23
- SETTING CHANNEL PARAMETERS 24
- INDIVIDUAL CHANNEL VIEW 25
- FREE CONSOLIDATOR+
CONFIGURATION SOFTWARE 27
- MODBUS CLIENT, SNOOPER &
SPOOFER ADD-ON FEATURES. 34
- USB DATA LOGGER ADD-ON FEATURE. . 35
- BATCH CONTROLLER ADD-ON
FEATURE 39
- CONNECTIONS 40
- SPECIFICATIONS 45
- DIMENSIONS. 60
- CONSOLIDATOR+ ENCLOSURES 62
- ACCESSORIES 63
- ORDERING INFORMATION 64

OVERVIEW

The ConsoliDator+ is a multivariable controller that is both easy to use and satisfies a wide variety of process display, alarm, and control applications. It accepts 4-20 mA inputs, flow meter pulse inputs, temperature inputs, digital inputs, and Modbus inputs and displays them in both numeric and bargraph format on a large, 5.7" color display.

It can be equipped with multiple relays with user-definable actions, 4-20 mA outputs, digital outputs, Modbus RTU & ASCII, Modbus Enron, and Ethernet Modbus TCP/IP protocol communication. Additionally, the controller is equipped with up to 30 timers that can be used to control many processes or events.

New features that have been added to the ConsoliDator+ include:

- (4) Temperature Inputs Card
- (15) Digital Inputs Card
- Auto-Tune PID Control
- Digital Switches (HOA)
- Advanced Batch Control Features
- Print batch tickets, process variables, and other critical data
- Pump Alternation with On-Off Multi-Setpoint and Lead-Lag Control

The ConsoliDator+ takes full advantage of its color display by allowing the user to customize screen colors for bargraphs, alarm conditions, and input channels.

All this functionality is easily programmed using the free software or via the front panel pushbuttons. Choose the model that best suits your application, from monitoring only to fully loaded controllers with an extensive combination of inputs, outputs, and communication protocols.

The standard product offering is listed in the ordering guide and other models are available for special order. The Add-On features expand the functionality of the ConsoliDator+, see ordering information for details.

Most ConsoliDator+ models have been Certified by Underwriters Laboratory (UL & C-UL) for use in ordinary locations (electrical safety) and in Div 2 hazardous area locations (nonincendive). See Ordering Information for complete details.

SCREENS

The ConsoliDator+ can be programmed to display the data on up to 20 different screens in a variety of formats and colors, with and without bargraphs. The following screens show a typical main screen and channel details screen:

Main Screen

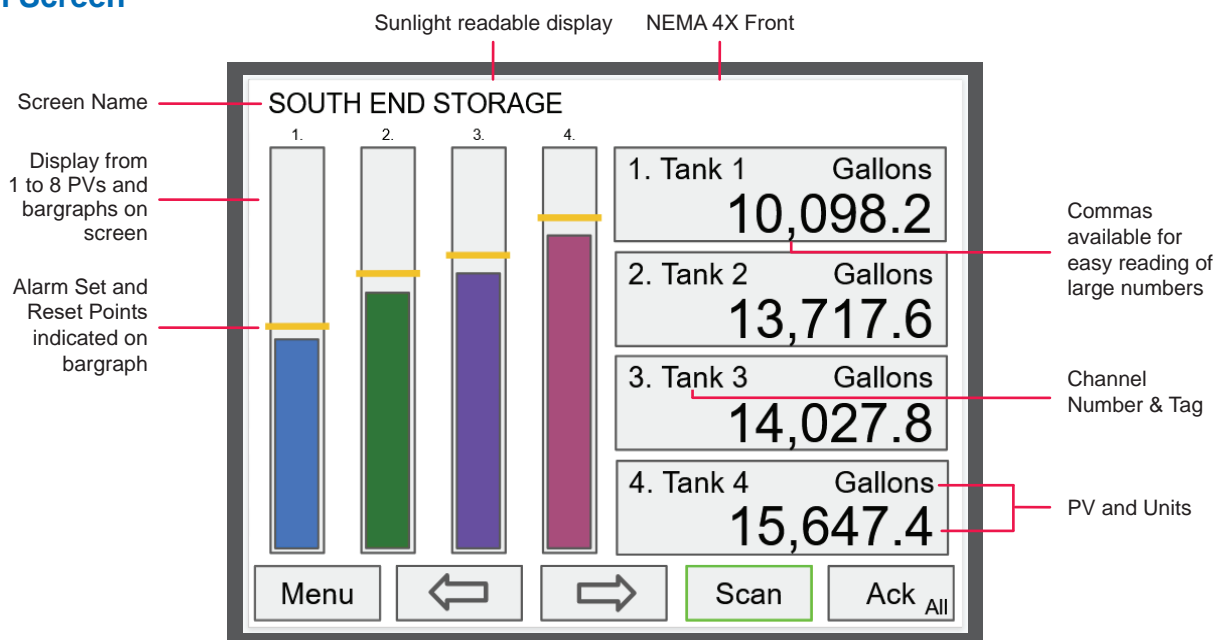

Channel Details Screen

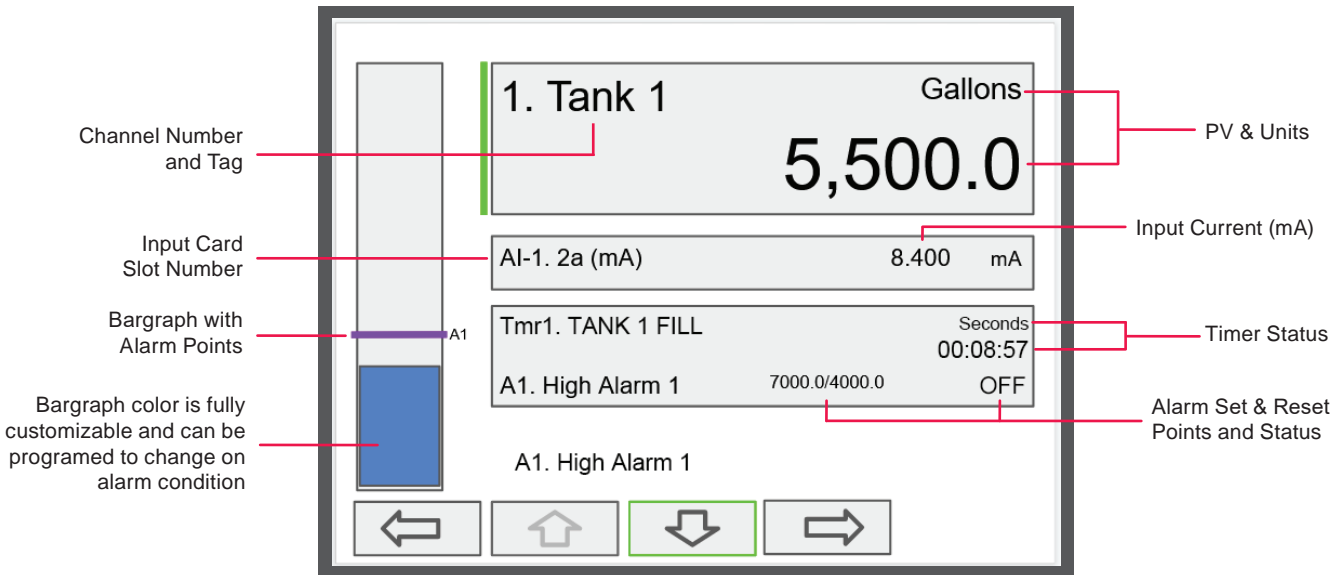

Screen with Feet & Inches Units

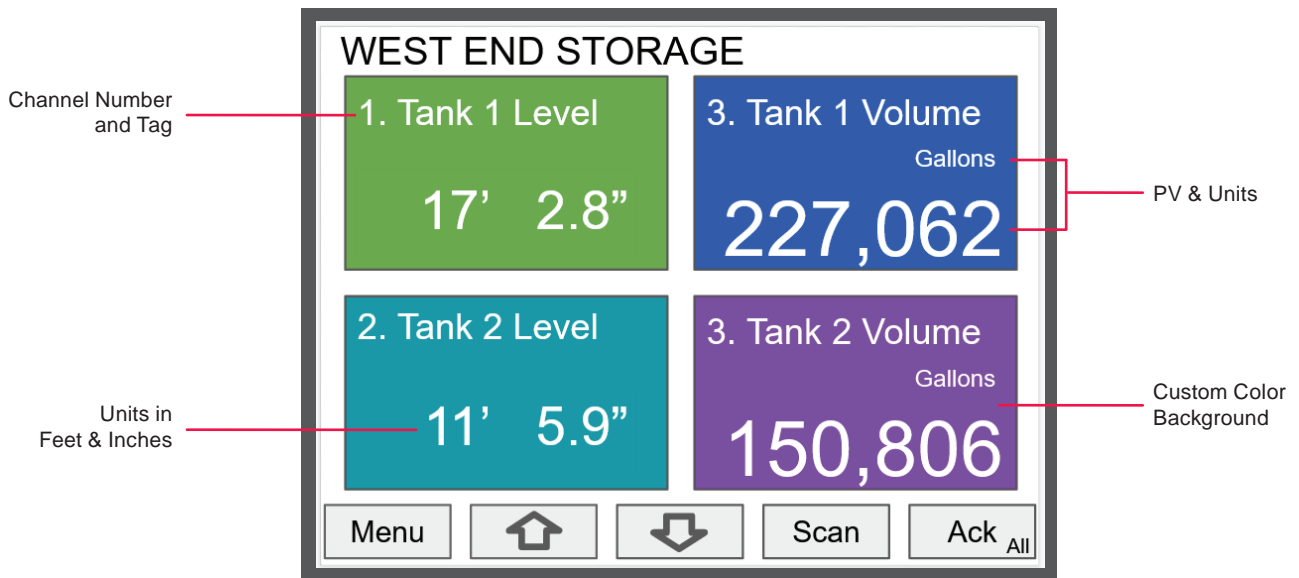

APPLICATIONS

Pump Control

Application #1: Lead-Lag Pump Controller with Alternation

One of the most common applications for the ConsoliDator+ is as a pump controller based on a 4-20 mA level sensor. This latest release makes the ConsoliDator+ an even better pump controller! The ConsoliDator+ has always had pump alternation capability but now we've made it easier to implement and added more functionality. A new On-Off Multi-Set channel allows for quickly building multiple set point operations, such as set points for controlling multiple pumps in lead-lag control. Adding pump alternation, which alternates which pump is the lead pump at each activation is more straightforward than ever. Additional control functions, such as HOA switches or overriding alarms can be easily implemented into the pump control logic.

Pump Control Details Screen

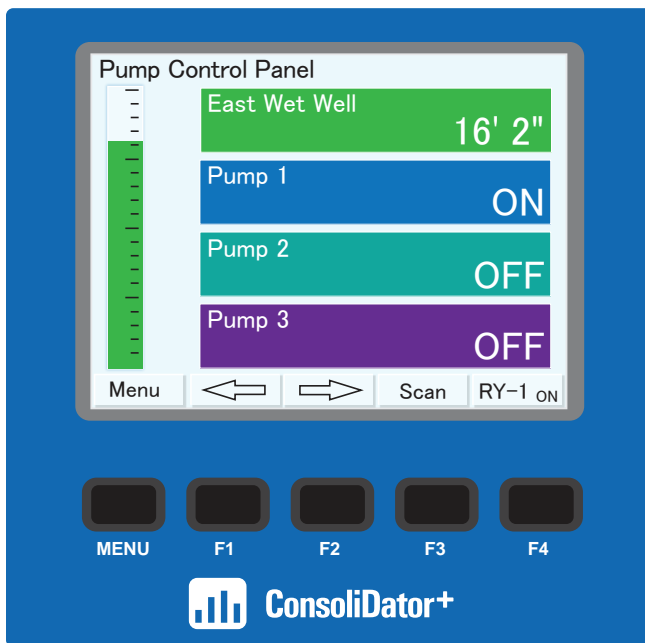

ConsoliDator+ screen showing the status of 3 pumps programmed for lead-lag with pump alternation. Pump 1 status is ON, pumps 2 and 3 statuses are OFF. This screen also displays the wet well in feet and inches. A bargraph is included on the display for a visual representation of the wet well level.

Pump Control Channel Setup

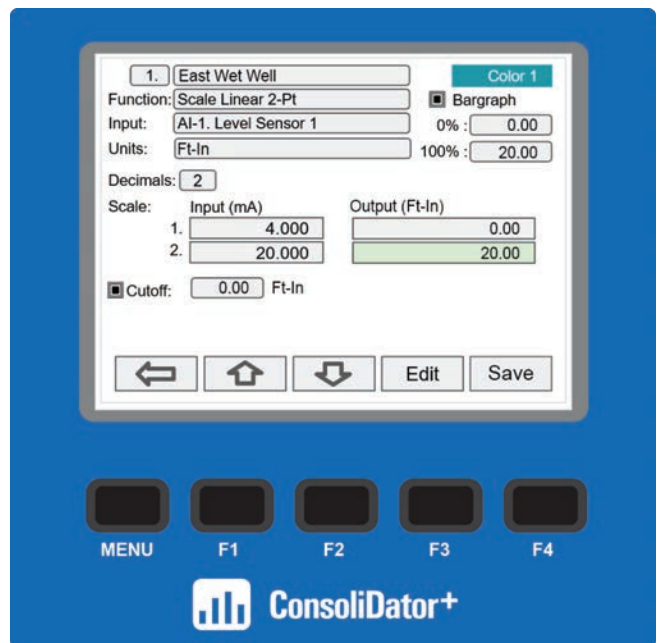

Most level control applications use level channels as the input to On-Off Control channels. The level channel is set up to read the signal from a level transmitter and display the level either in height or volume units. The continuous level monitoring allows for selecting multiple alternation points.

On-Off Multi-Set Channel Setup

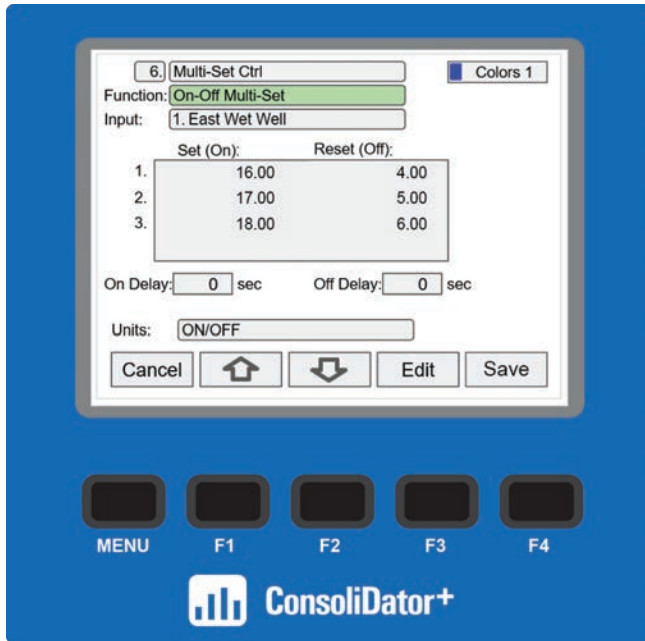

This screen shows the setup of a channel using the On-Off Multi-Set feature. Instead of using multiple channels for On-Off control, one channel can be set up with multiple different set and reset points. This allows the user to see all their set and reset points in one place and allows for tighter control of the process.

Lead-Lag Channel Setup

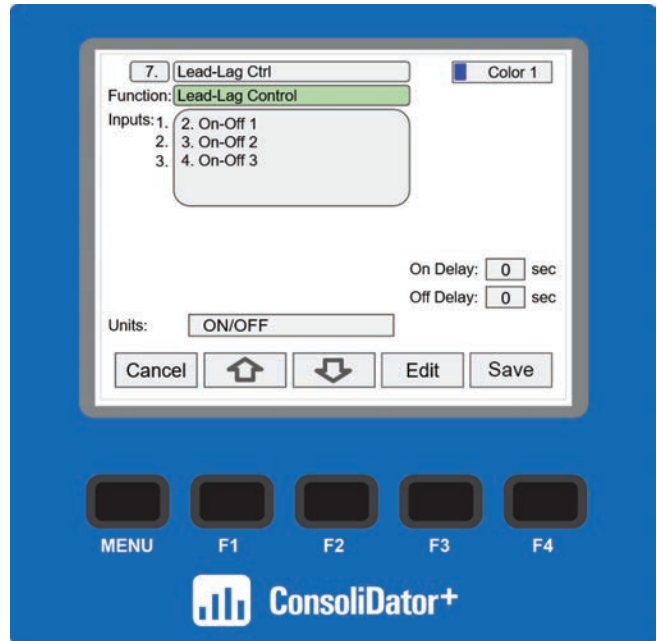

The Lead-Lag Control channel uses the On-Off channels as the input. The main pump (Lead) always turns on first, the secondary pumps (Lag) turn on only if the main pump is not able to maintain the level below the additional On/Off control points.

Monitoring Wet Well Level & Controlling Three Pumps

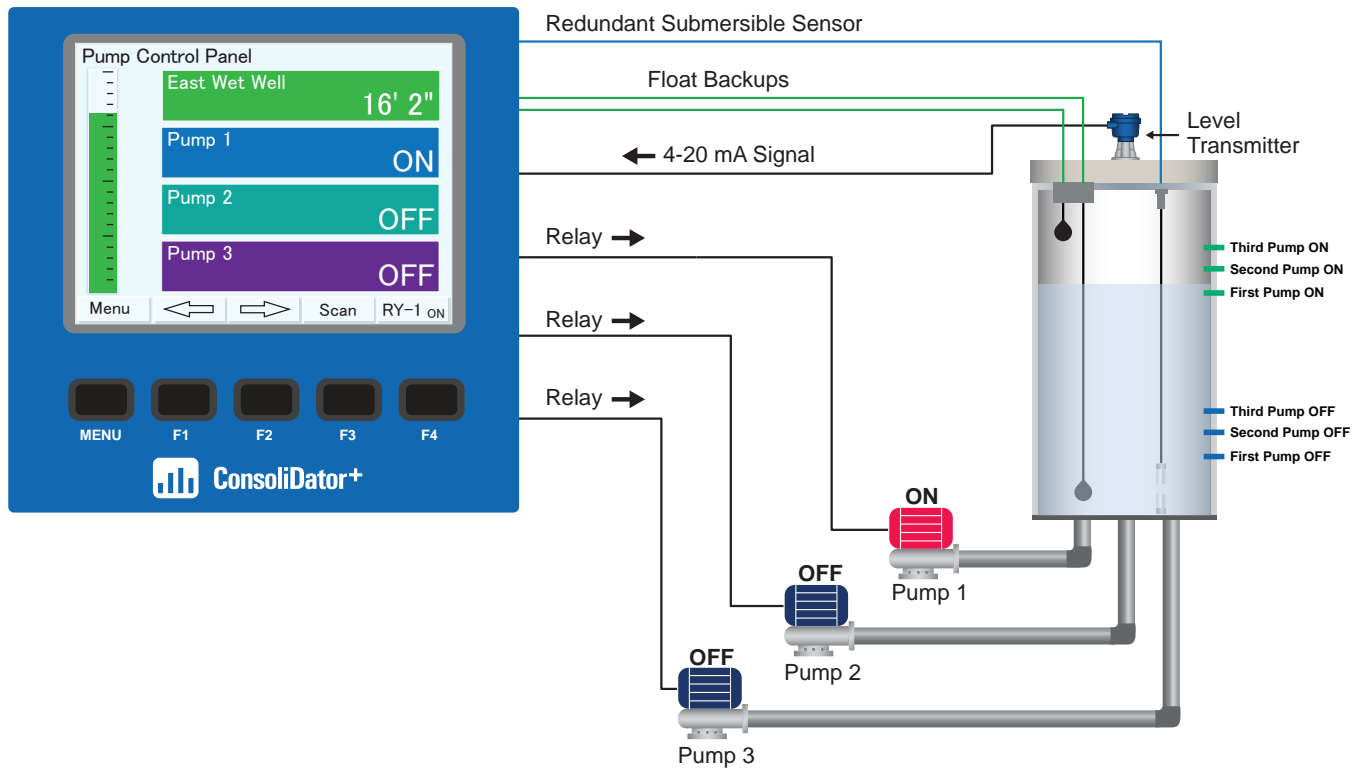

In this example, the ConsoliDator+ utilizes Lead-Lag with Pump Alternation and On-Off Multi-Set features to control the level in the wet well with three pumps via relay outputs. A level transmitter located atop the well sends a 4-20 mA signal to the ConsoliDator+, which displays pump statuses and level in feet & inches. The ConsoliDator+ will automatically switch to a redundant sensor if the primary fails. Float backup status can also be indicated on screen.

Features Used:

- Multiple On/Off set points with optional randomization.
- Remote addressable set points.
- Lead-Lag with or without alternation.
- Alternation based on time.
- Delayed and staggered pump start up after power loss.

Application #2: HOA Switch Feature for Pump Control

The ConsoliDator+ allows control of pumps using the HOA switch feature. It provides a setup for controlling a pump that fills a wet well based on its level, with options to configure well level and on/off control channels.

HOA Configuration Window

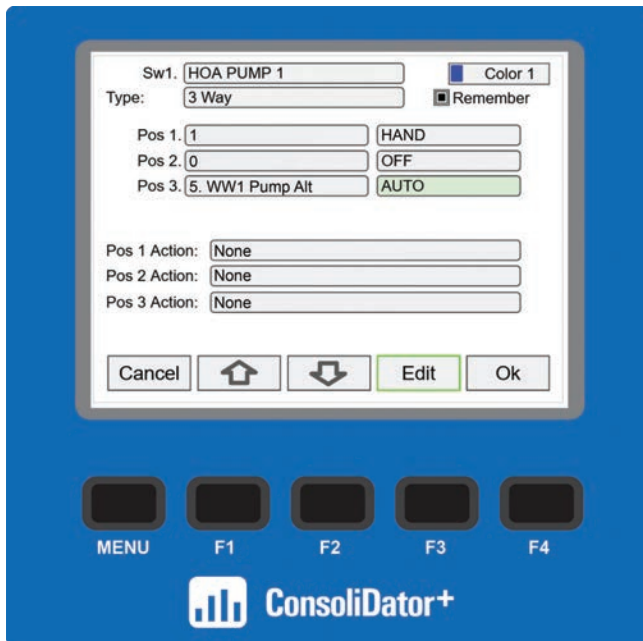

Pump Control Details Screen

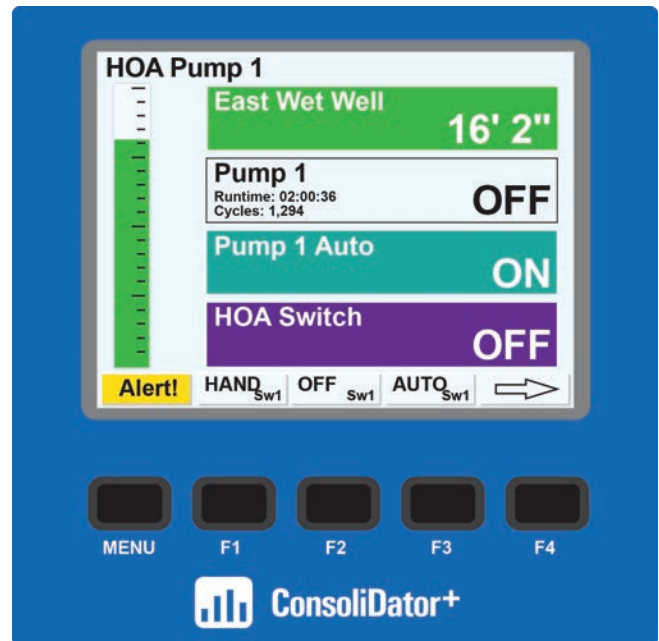

This screen shows the setup of an HOA switch to manage a wet well-filling pump based on well levels. A three way switch is configured to control each of the two pumps operating the system. To manage the pump alternation sequence, a pump alternation channel for wet well 1 was created and called "WW1 Pump Alt." The switch for pump 1 is titled HOA (HAND/OFF/AUTO) Pump 1. It will manage the first of the two alternating pumps.

The on-screen HOA switch is programmed with the following positions:

- Position 1: 1, or always on. This is labeled as "HAND" mode.
- Position 2: 0, or always off. This is labeled as "OFF" mode.
- Position 3: This position will direct the pumps to operate as called for by the pump alternation channel for wet-well 1.

The HOA switch will operate the pump based on the following positions:

- Position 1: Activated Relay 1 (HAND)
- Position 2: Deactivates Relays 1 (OFF)
- Position 3: Engages Automation Control Mode

A second switch can be configured for HOA control of pump 2.

In this example, the ConsoliDator+ is displaying critical information relevant to this wet well application and provides soft-keys for controlling the pump.

The display includes:

- Well level in Feet and Inches
- An Alert! message signaling that the pump has been manually turned off
- Indicates the HOA (Hand-Off-Auto) switch in the Off position
- Provides Pump 1 relay runtime and cycle count
- Prompts user to press the F3 key (AUTO) to switch to automatic control
- Bargraph for visual representation of the wet well level

Gas Detection

ConsoliDator+ Used for Alarming in Gas Detection

A power plant facility that uses ammonia to reduce NOx emissions replaced its old, degraded controller with the PD9000 ConsoliDator+ Multivariable Controller.

The facility receives ammonia in bulk from tanker trucks and is dispensed into a storage tank. The PD9000 controller was installed and configured to display and monitor the readings from two sensors that detect ammonia gas leaks at the fill points on top of the storage tank. Ammonia can be very toxic at high concentrations.

Given ammonia is not flammable, a water deluge system is needed to dilute the concentration of ammonia in the area. The water deluge system changes the chemical properties by bonding it with water, and therefore, keeps the ammonia gas exposure at safe levels.

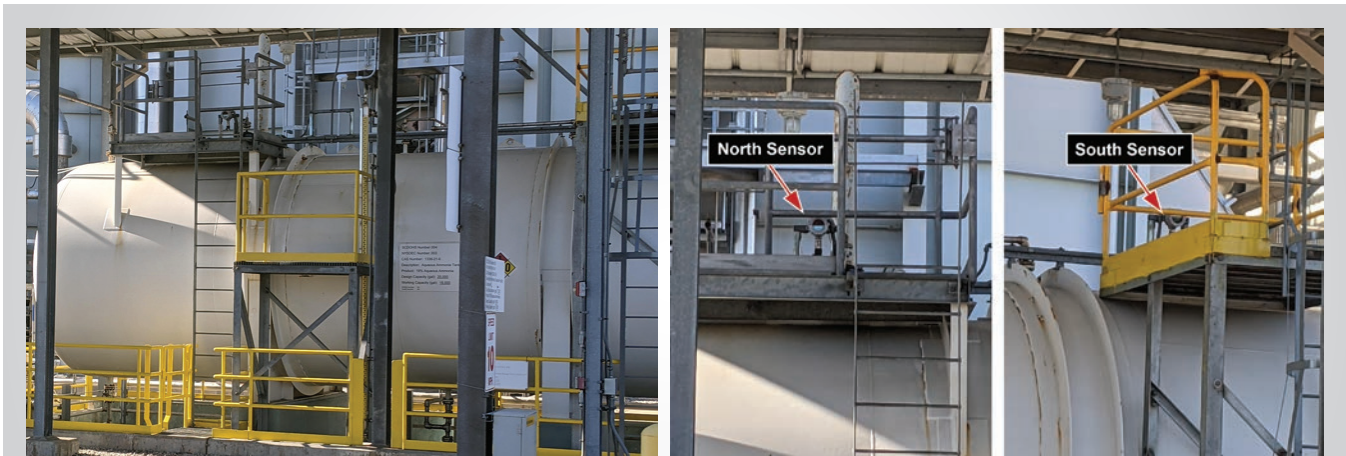

Two sensors located on top of the ammonia storage tank. One is located at the north end and the other is located at the south end of the tank as indicated on the display of the ConsoliDator+.

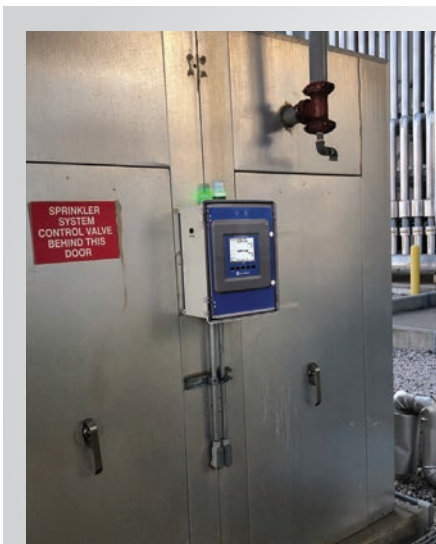

The ConsoliDator+ PD9000 was installed near the ammonia tank on the outside panel of the sprinkler system.



The ConsoliDator+ is fully protected from the elements by a PDA3939 NEMA 4X plastic enclosure that includes a clear front door for easy access.



The ConsoliDator+ replaced this old degraded controller. The small display is hardly readable and it is exposed to the outside elements.

With the use of its relay and alarm capabilities, the PD9000 was configured to activate a warning alarm at 20 ppm and a high alarm at 45 ppm which engages the deluge system.

A 3-color light/horn (PDA-LH3LC-RYG) was installed on top of the PD9000 for ample sound and visibility of the alarms. The light/horn is configured to flash the amber light at the 20 ppm to indicate a warning and flash the red light at 45 ppm to indicate a high concentration of the ammonia gas.



The [PDA-LH3LC-RYG](#) Light/Horn was installed on top of the PDA3909 enclosure which contains the PD9000. The light/horn includes 3-layers of colors; Red, Yellow, and Green.

An additional alarm was configured to flash the amber light in case a sensor break has occurred.

In addition to external alarms, the ConsoliDator+ can display visual alarms on the screen with the use of color-changing channels to help draw operators' attention to a potential hazard.

Gas detectors must be calibrated often and can give erroneous outputs during calibration that may cause false alarms to occur. To prevent this, an "Inhibit Mode" feature was configured on the PD9000 in which the operator presses a button on the ConsoliDator+ to force off and disable any active alarms that could potentially turn on the sprinkler system when it's not actually needed.

The operator can then press the button after the calibration is finished to return the ConsoliDator+ to "Run Mode". Or, if the operator forgets to manually put the controller back into "Run Mode", the ConsoliDator+ will automatically switch back without operator input thanks to the timer functions on the ConsoliDator+.

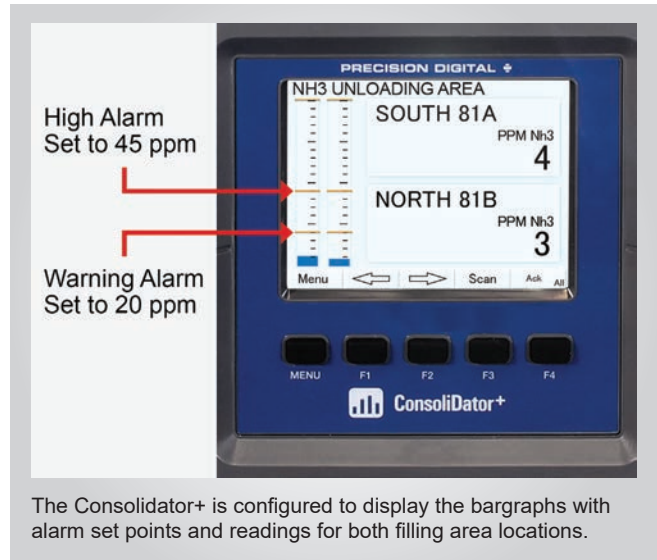

The ConsoliDator+ is configured to display the bargraphs with alarm set points and readings for both filling area locations.

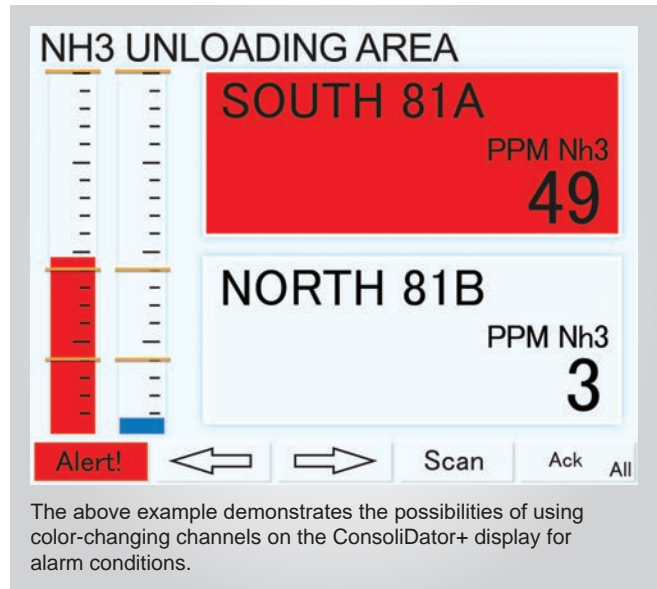

The above example demonstrates the possibilities of using color-changing channels on the ConsoliDator+ display for alarm conditions.

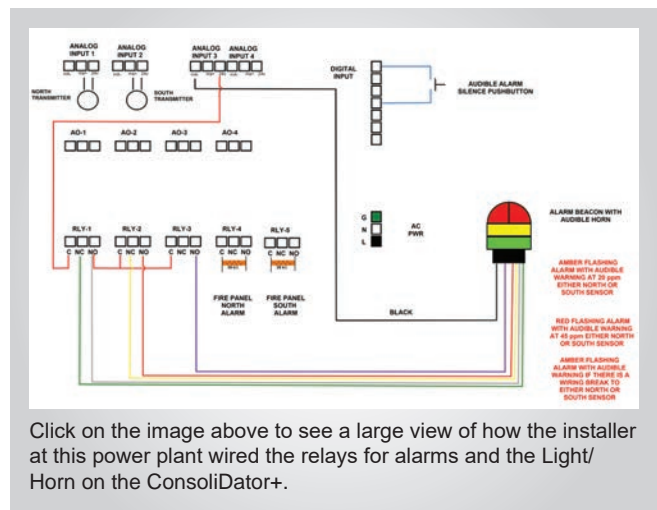

Click on the image above to see a large view of how the installer at this power plant wired the relays for alarms and the Light/Horn on the ConsoliDator+.

Batch Control

Batch Control with Ticket Printing

The new batch control features enable single-stage or two-stage batch processing, with options for manual or automatic operation. Users can configure up to 16 batches, running them simultaneously or sequentially. During the batch process, various actions can be selected to control lights and horns, providing operators with crucial process information. In addition, a custom ticket can be printed at the end of the batch.

The ConsoliDator+'s 5.7" color display provides a multi-screen graphical interface to display critical information about your batch control application as well as other peripheral information that might be useful to see. For instance, the ConsoliDator+ can display batch control information such as batch preset value, batch preclose value, running batch, flow rate, batch count, and batch grand total. In addition, The ConsoliDator+ can display other data such as pressure, level, temperature, pH, etc. from various 4-20 mA transmitters. A custom ticket can also be printed to act as a receipt for the batch using the available [PD920-DP](#) Desktop Ticket Printer. Custom ticket printing is easy to set up with the free ConsoliDator+ programming software.

Detailed Batch Control Screen

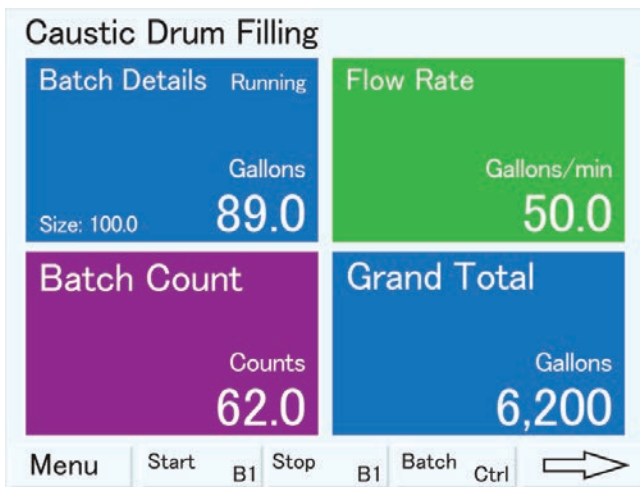

ConsoliDator+ batch screen showing the batch size, volume in gallons, flow rate, batch count, and batch grand total.

Ticket Printing Capability

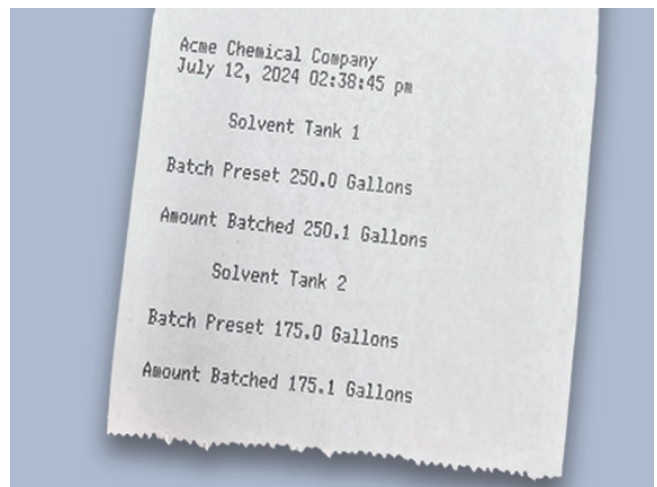

Information about the batch can be printed using the available PD920-DP desktop ticket printer and is easy to set up using the free ConsoliDator+ programming software.

Batch Control Application Examples

Example #1: Simultaneous Batch Control of Two Ingredients and Ticket Printing

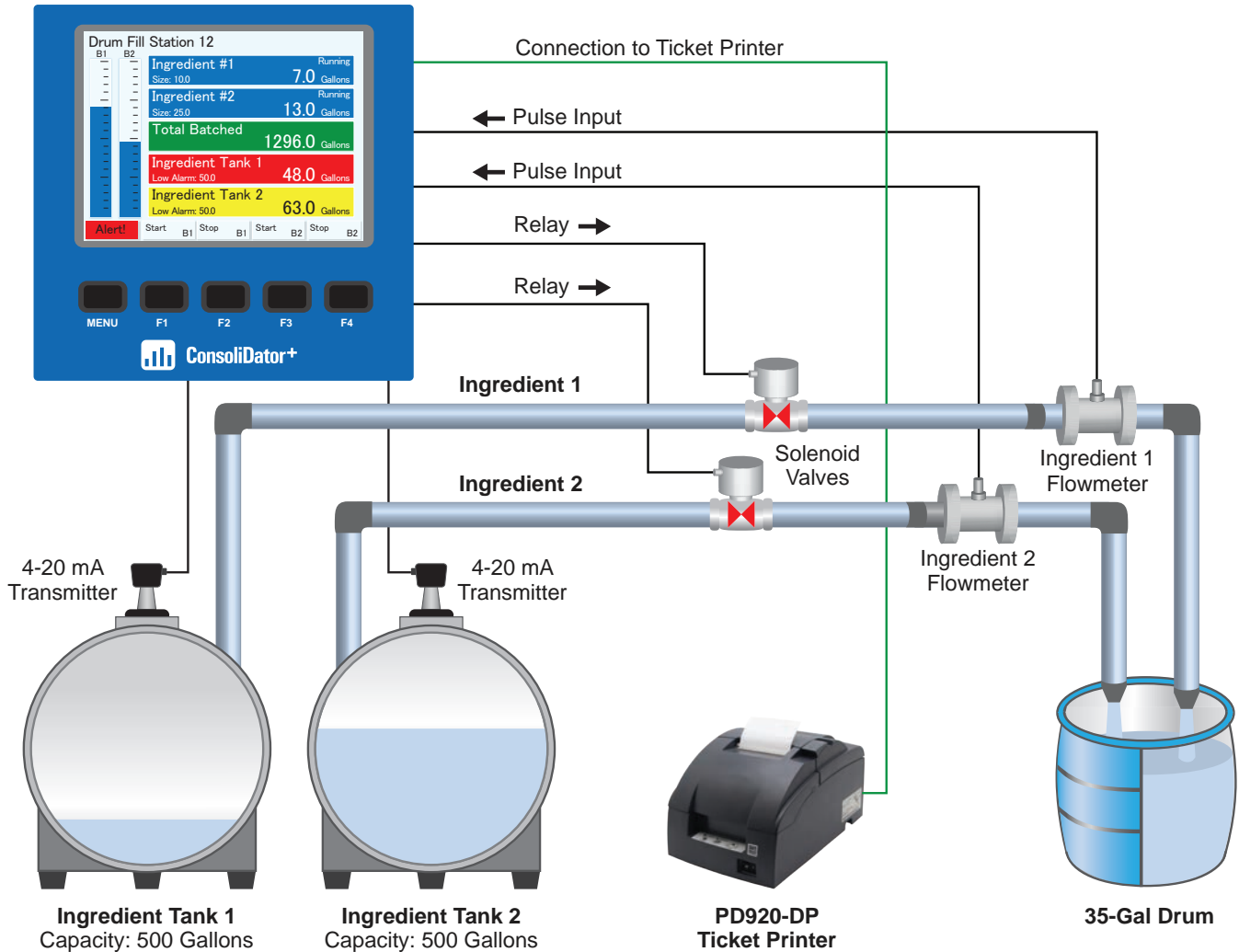

In this example, the ConsoliDator+ is performing two single-stage batches by reading the pulse inputs from the flowmeters and closing the solenoid valves when the batches are complete. The ConsoliDator+ is also displaying the level in the two source tanks from 4-20 mA level transmitters and indicating a low alarm situation for Tank 1. A ticket printer is connected to the ConsoliDator+ for printing critical information about the batch process. The batches can be started and stopped with the soft keys on the ConsoliDator+. The bargraphs provide a handy visual of how far along the batch is. Additional screens are available for displaying individual batches or other details.

Example #2: Dual Stage Batch Control with Preclose & Preset

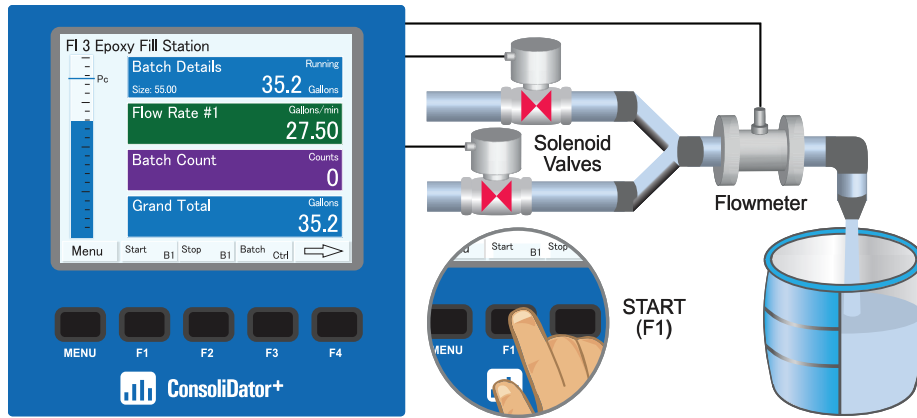

In this example, the ConsoliDator+ controls a full-flow valve and restricted-flow valve to provide more accurate batching of 55-gallon drums. A preset of 55.00 and preclose of 5.00 are set in the ConsoliDator+. The batch operation starts when the F1 (Start) button on the ConsoliDator+ is pressed. The full-flow valve closes at 50.00 when the preclose of 5.00 is reached. The restricted-flow valve remains open until the preset of 55.00 is reached, at which point the batch is completed. The bargraph provides a handy visual of how far along the batch is.

Example #3: Multiple (Different Size) Batches Run Simultaneously Displayed on Multiple Screens

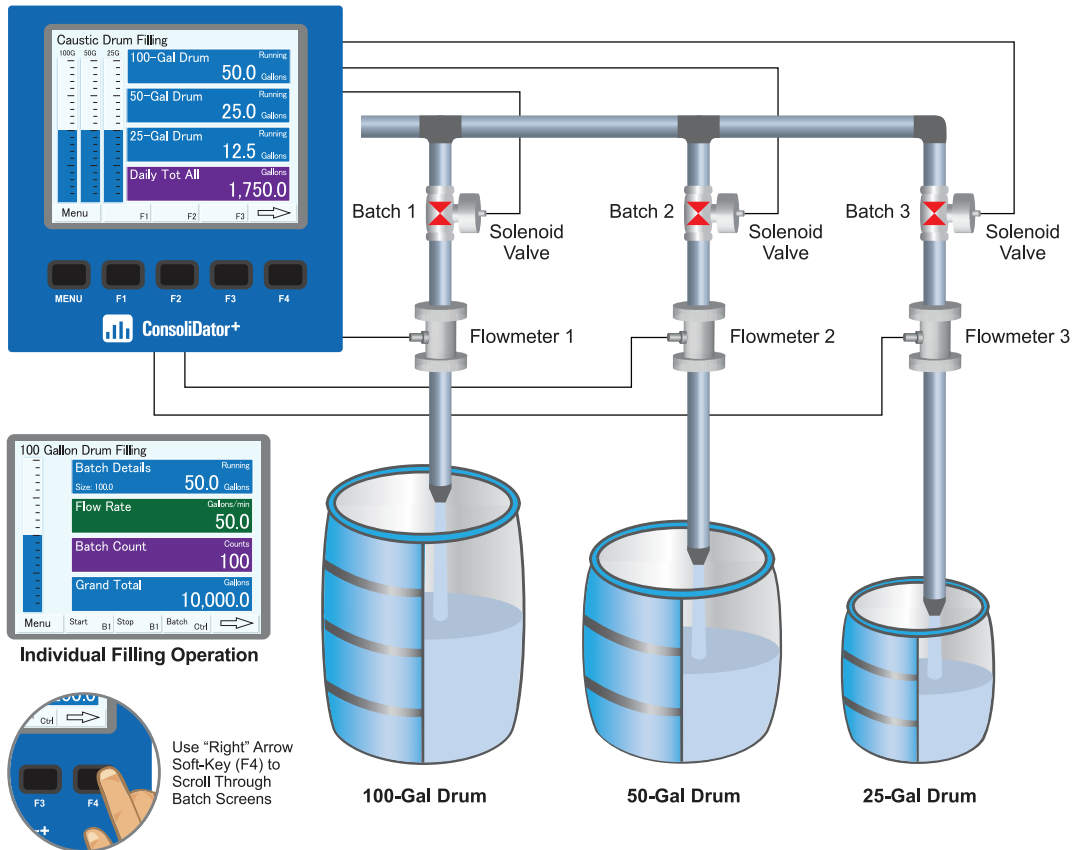

In this example, The ConsoliDator+ controls the simultaneous filling of multiple drums of different sizes using individual controls for each drum. The ConsoliDator+ can display information on multiple screens to help the operator follow along with the progress of the operation. The upper graphic depicts a screen of the overall drum filling operation, and the lower graphic depicts a screen of an individual drum filling operation. The operator scrolls through these screens with the F4 (right arrow) button.

Example #4: Multiple Batches Run in Sequence

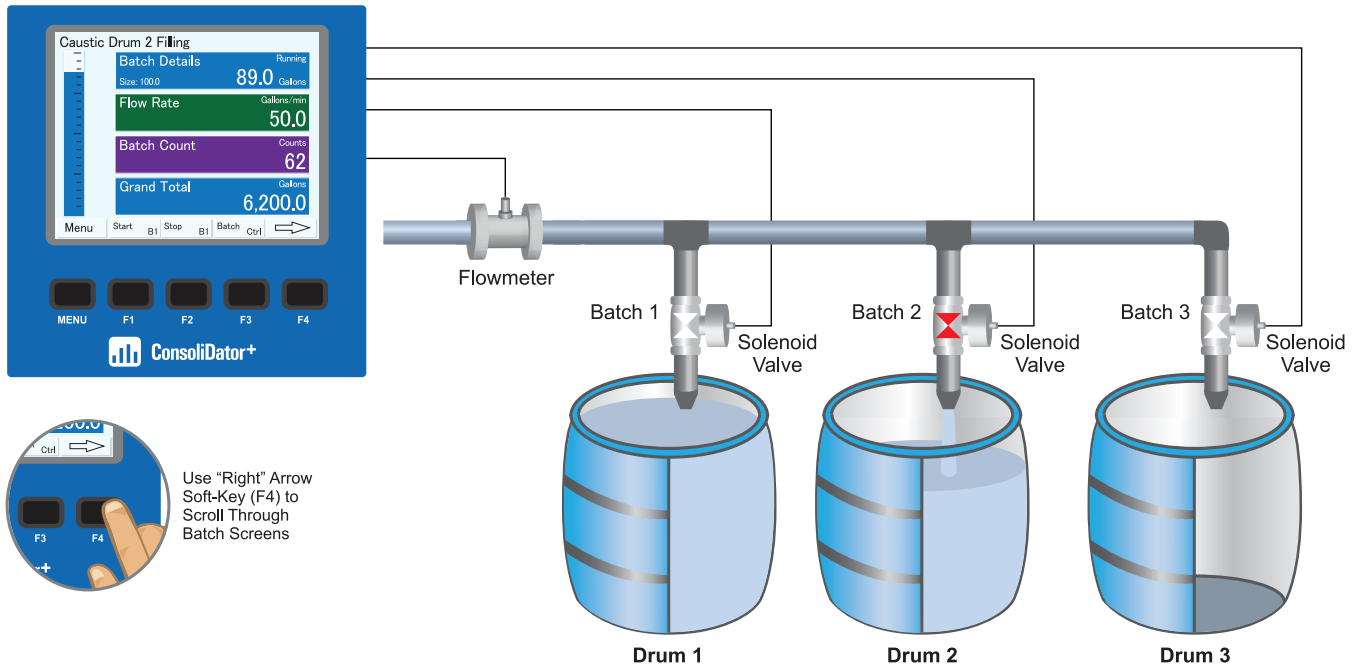

In this example, The ConsoliDator+ controls the filling of multiple drums sequentially using individual controls for each drum. The ConsoliDator+ is currently displaying the screen for the Caustic Drum 2 Filling operation. The operator can see the details for the other two filling operations and a view of the overall operation by pressing the F4 (right arrow) key.

Manual Batch Control

The manual batch control feature is used for batch processes that the operator wants to start manually. It can also be used when the batch size needs to be manually adjusted for each batch. The batch can be controlled by the button on the controller or a digital input.

Step 1: System Setup

Both valves are closed with an empty barrel in place. The batch screen is set up to display the batched total, rate, batch count, and grand total of completed batches.

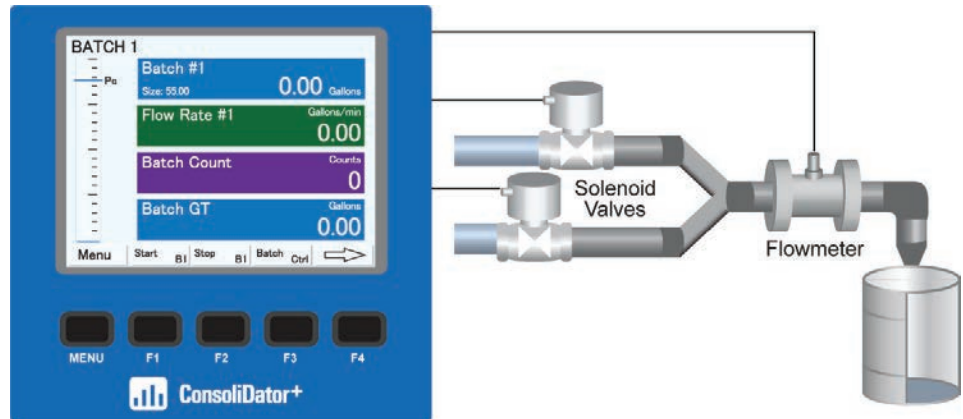

Step 2: Batch Start

The START button or (F1) is pressed. Both valves open. The barrel begins to fill.

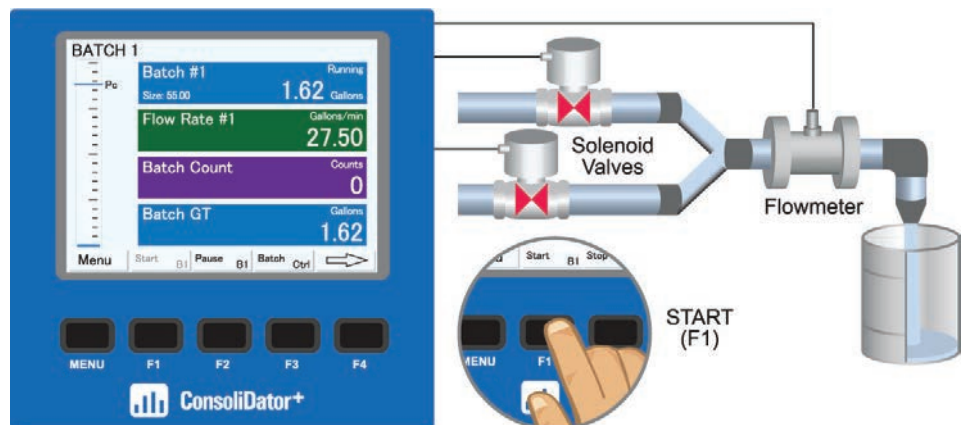

Step 3: Preclose Valve

When the batch total reaches a value of 50.00 (Preset [55.00] – Pre-close [5.00]) the full-flow valve closes. The fill rate of the barrel slows as a result.

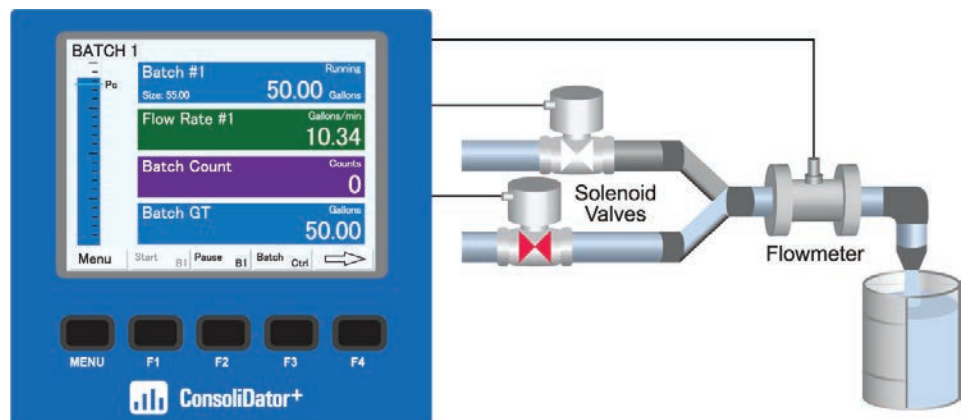

Step 4: Completed Batch

When the batch is complete, the restricted-flow valve closes.

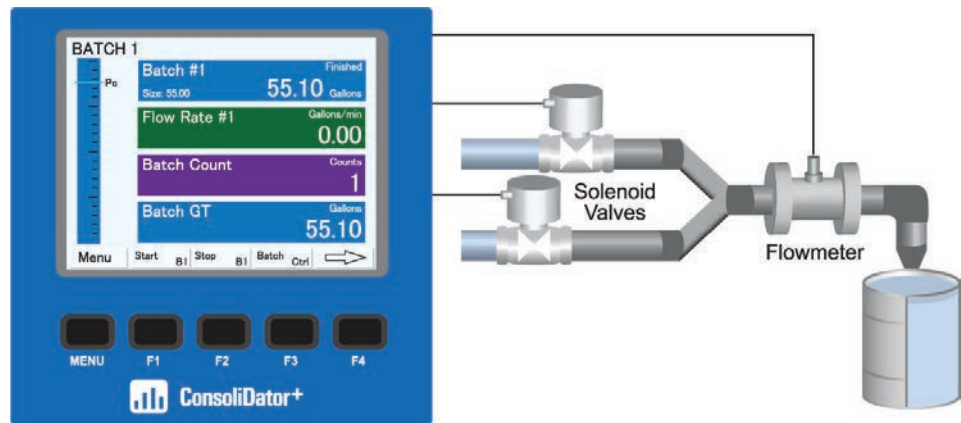

Step 5: Overrun Correction

If an overrun occurs, the controller automatically makes the adjustment to compensate for the overrun. The next batch will only start after the START button or (F1) is pressed.

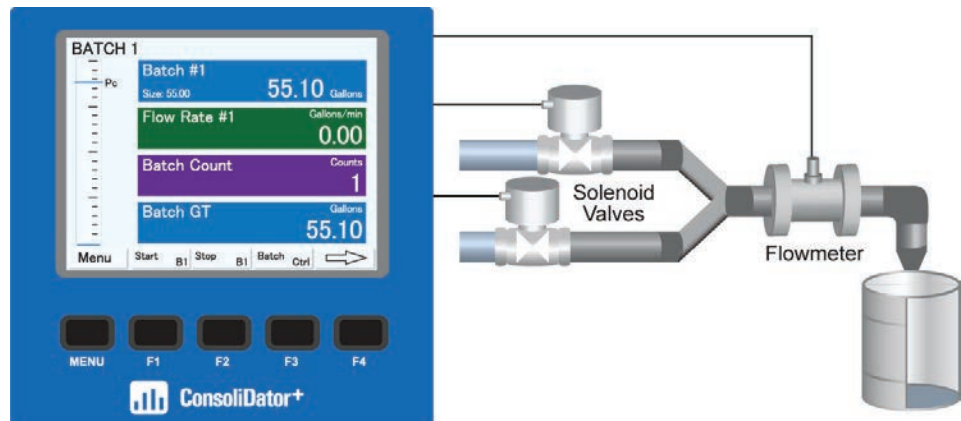

Step 6: Manual Start of Next Batch

A new, empty barrel is put in place and the START button or (F1) is pushed to manually start the next batch.

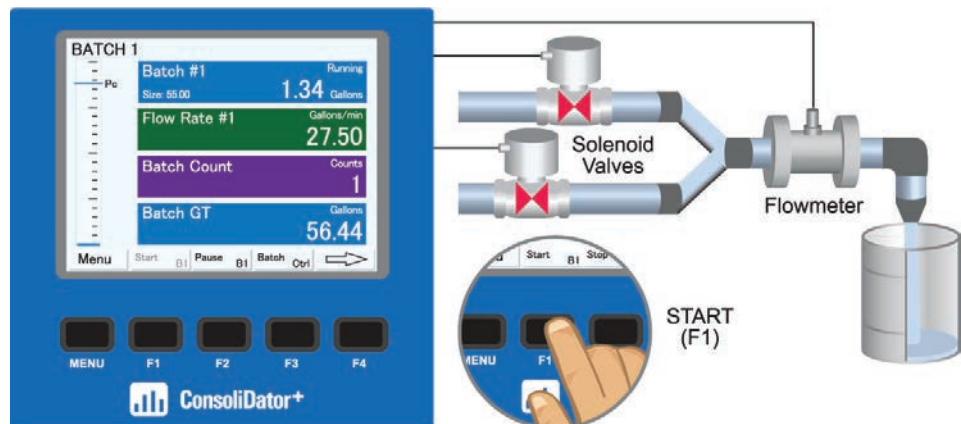

Step 7: Change Batch Size

While the process is stopped, a new preset fill amount may be selected with the Batch key (F3) for a different size barrel.



Step 8: Pause/Stop

At any time, press the Pause/ Stop button or key (F2) once to pause the process, or twice to stop and cancel the batch, which stops the process.

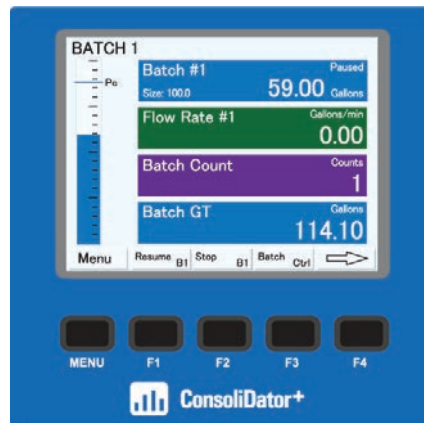

Step 9: Resume Batch

If the batch has been paused, then press the Resume button or (F1) to resume the batch process.

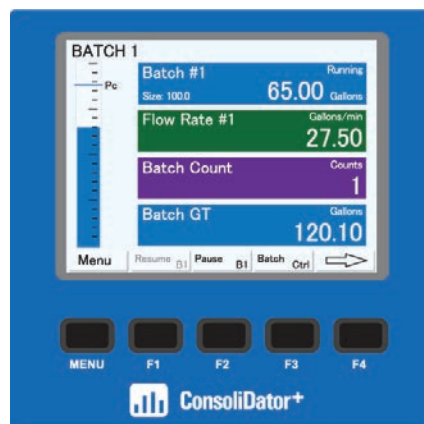

Automatic Batch Control

The automatic batch control feature is used for batches that start automatically once the previous batch is completed. There is no opportunity for the operator to change the batch size between batches. The batch can be controlled by the button on the controller or a digital input.

Step 1: System Setup

Both valves are closed with an empty barrel in place. The batch screen is set up to display the batched total, rate, batch count, and grand total of completed batches.

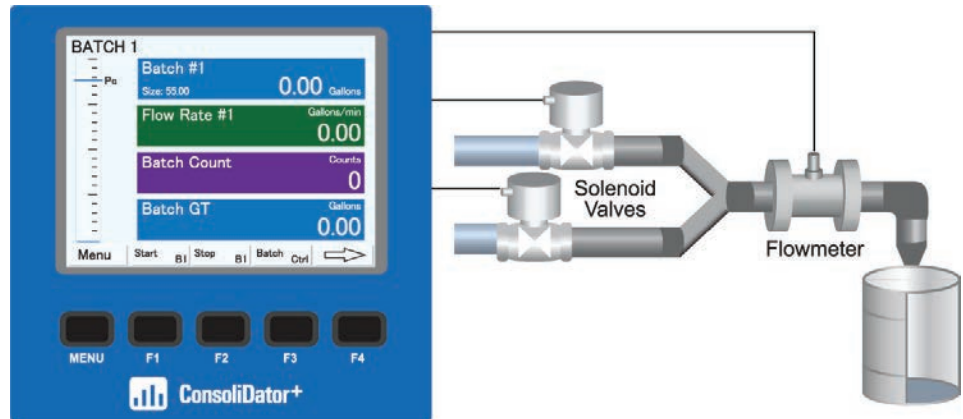

Step 2: Batch Start

The START button or (F1) is pressed. Both valves open. The barrel begins to fill.

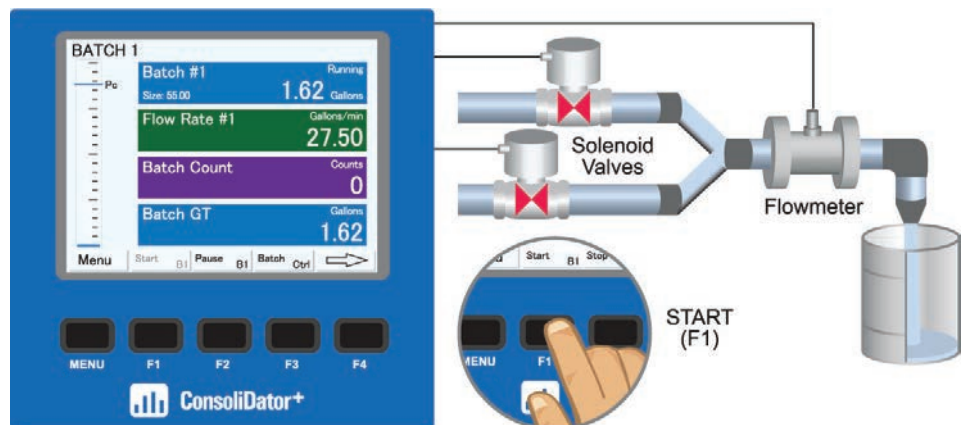

Step 3: Preclose Valve

When the batch total reaches a value of 50.00 (Preset [55.00] – Pre-close [5.00]) the full-flow valve closes. The fill rate of the tank slows as a result.

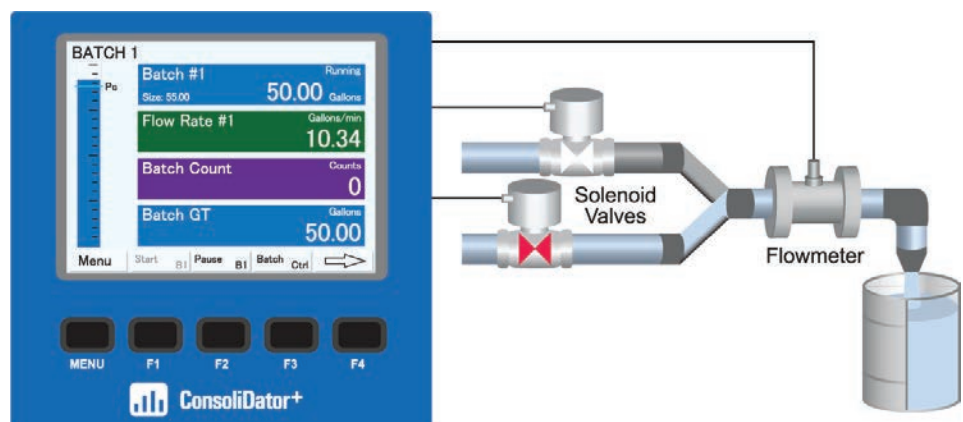

Step 4: Completed Batch

When the batch is complete, the restricted-flow valve closes. If overrun occurs, then the preset must be adjusted to compensate for the overrun.

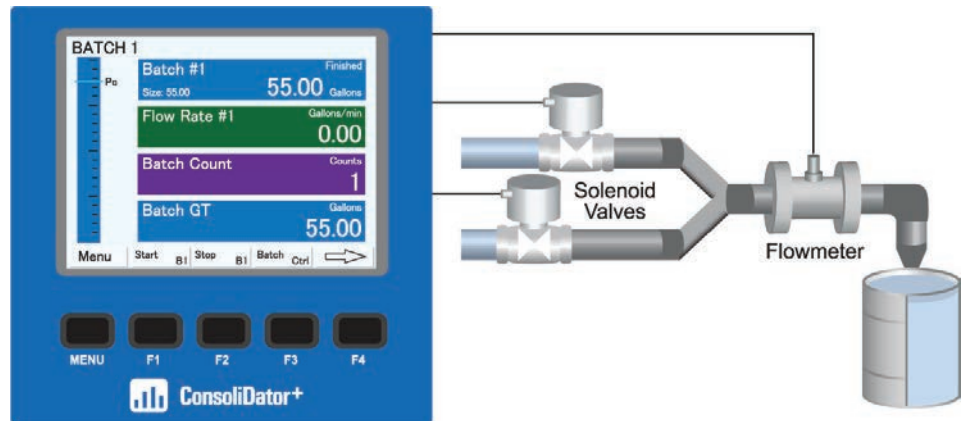

Step 5: Start Delay

After the batch is completed, the operator removes the full barrel and places an empty barrel; the new batch starts automatically after 60 sec-onds (Time Delay).

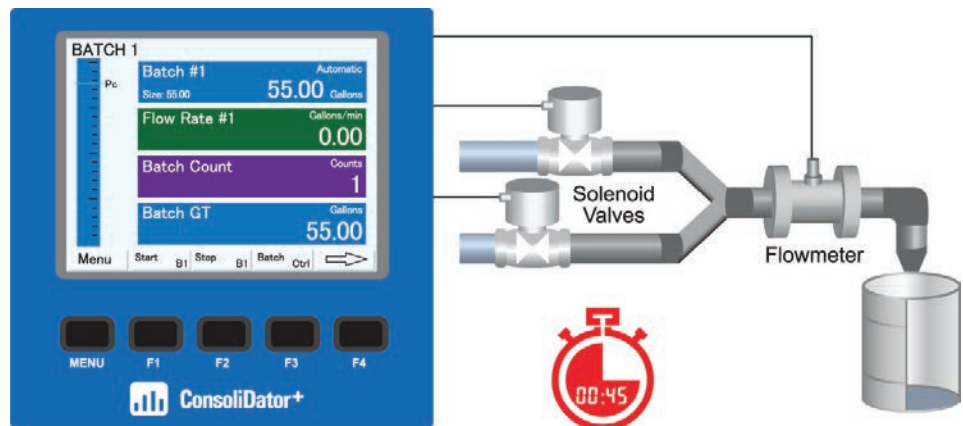

Step 6: Automatic Start of Next Batch

The new batch begins automatically after 60 seconds, both relays activate and both valves open.

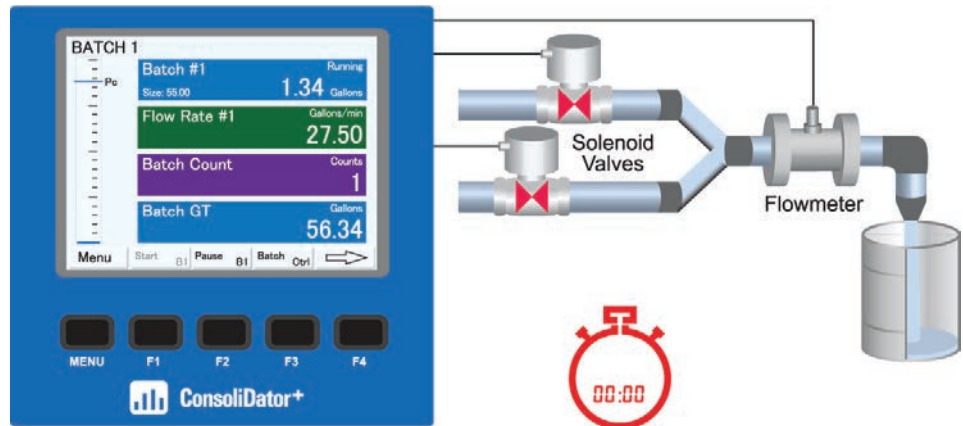

Step 7: Pause

At any time, press the STOP button or Stop key (F2) once to pause the process.

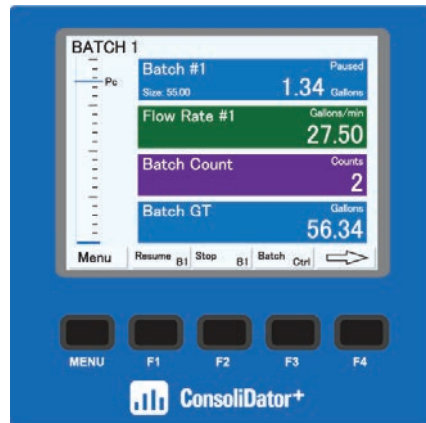

Step 8: Resume Batch

If the batch has been paused, then press START button or (F1) to resume the batch process.

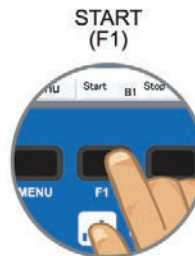

Step 9: Stop Process

At the end of the shift, press STOP button or Stop key (F2) twice to stop the batch process.

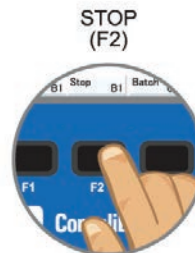

Chemical Bulk Storage

Monitoring Level in Three Chemical Tanks

This wastewater treatment plant has installed a ConsoliDator+ PD9000 multivariable controller to monitor chemical level in gallons in three distinct tanks. The PD9000 simultaneously displays data for two Hypochlorite tanks and one Hydroxide tank, with a bargraph showing the levels of each tank. A light and horn system is integrated for high alarm notifications, while a silence button on the controller can mute the alarm. Additionally, a test button is available to check the functionality of the alarm circuitry.



Two Hypochlorite tanks and one Hydroxide tank located inside the building



ConsoliDator+ installed in enclosure and mounted on wall outside the building



Enclosure opened showing wiring to ConsoliDator+

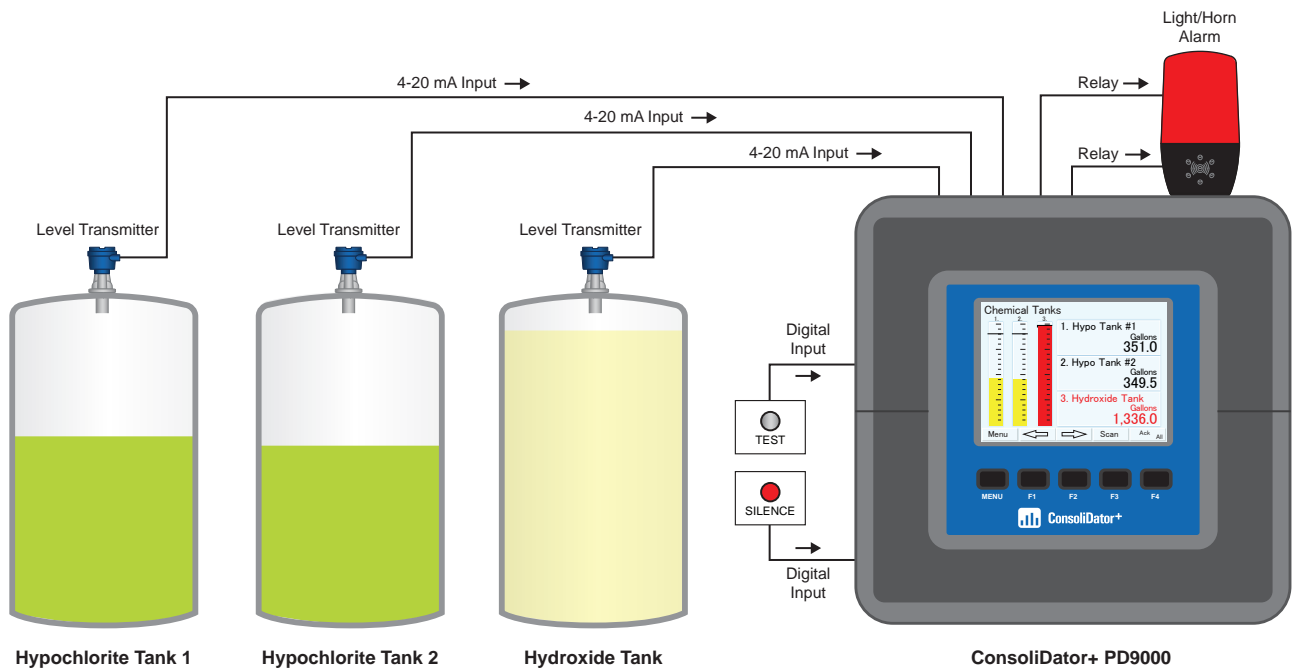

In this example, the ConsoliDator+ receives 4-20 mA signals from level transmitters mounted on top of each chemical tank, which are used to display the tank levels in gallons on the PD9000 controller. Two relays within the PD9000 are set up to activate a light and horn in case of a high alarm condition. A silence button is connected to one of the PD9000's digital inputs to mute the alarm, while a test button is connected to another digital input to verify the alarm circuitry's functionality. The levels for all three tanks are displayed in gallons on the PD9000 screen. Additionally, three bargraphs are displayed to give a visual representation of the level in each tank.

PRINTER CARD OPTION

The ConsoliDator+ can be equipped with the [PDA9000-CP](#) printer card, which installs into any available slot. With a printer card installed, the number of additional I/O cards that can be added is reduced to six. Precision Digital offers the [PD920-DP](#) desktop printer and the [PDA920-DP-WMK](#) wall mounting kit. The printer connects directly to the PD9000 using the included DB9M cable and is easily configured with the ConsoliDator+'s free programming software.



PD920-DP Ticket Printer

PD9000 ConsoliDator+

Ticket Printing Features:

- Custom ticket printing for batch process information & other uses
- Automatic and manual printing
- Free ConsoliDator+ software allows for easy setup of batch controller and ticket printer
- Select batch information for printing with up to 24 text entries
- Select action for when to print ticket
- Wall mounting kit available

Printer & Accessories

Printer & Wall Mounting Kit



Printer and Wall Mounting Kit Sold Separately

Model	Description
PD920-DP	Desktop Impact Printer, Plug-in Power Supply, and 10 ft DB9F to DB25M Null Modem Cable
PDA920-DP-WMK	Desktop Printer Wall Mount Kit

PDA9000-CP Printer Card

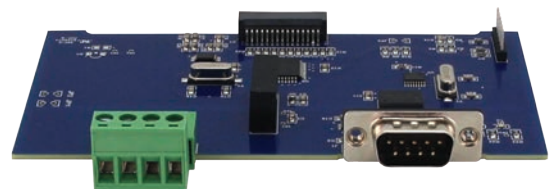

Printer Card Connections

The printer card output uses an RS-232 serial connection.

Cable Connection: DB9M - 10 ft DB9F to DB25M Null Modem Cable (Included with printer card)

Screw Terminal Connection: 5.0mm pitch (Rx, Tx, /CTS, GND)

Model	Description
PDA9000-CP	ConsoliDator+ Printer Card

Notes:

1. Use only 1 of the above connection options.
2. ConsoliDator+ models equipped with a printer card are not UL Listed.
3. Printer card occupies one I/O slot.

INPUTS & OUTPUTS

The back panel is labeled with the I/O boards that were installed at the factory. The removable connectors are labeled with the connection signal for each terminal. The following diagram shows what the back of the model PD9000-6N-4PI-4AI-4TI-5AO-5RY-15DI-E-P looks like.

This model is powered from 90-264 VAC, it accepts (4) pulse and (8) analog inputs and has (10) 4-20 mA outputs and (10) relays. (5) digital inputs, (4) digital outputs, RS-485 serial capability and USB connections are standard on all ConsoliDator+ models. Ethernet is an option.

If all Input/Output slots are used exclusively for one function, the ConsoliDator+ can accept up to (28) isolated 4-20 mA inputs, (28) pulse inputs, (25) isolated 4-20 mA outputs, or (25) relays.

If used as a Modbus Client, Snooper, or Server only: It can have (35) 4-20 mA outputs, 30 relays, or (20) 4-20 mA outputs and (15) relays.

Units are powered from AC or DC according to the power option ordered (AC: -6 or DC: -7).

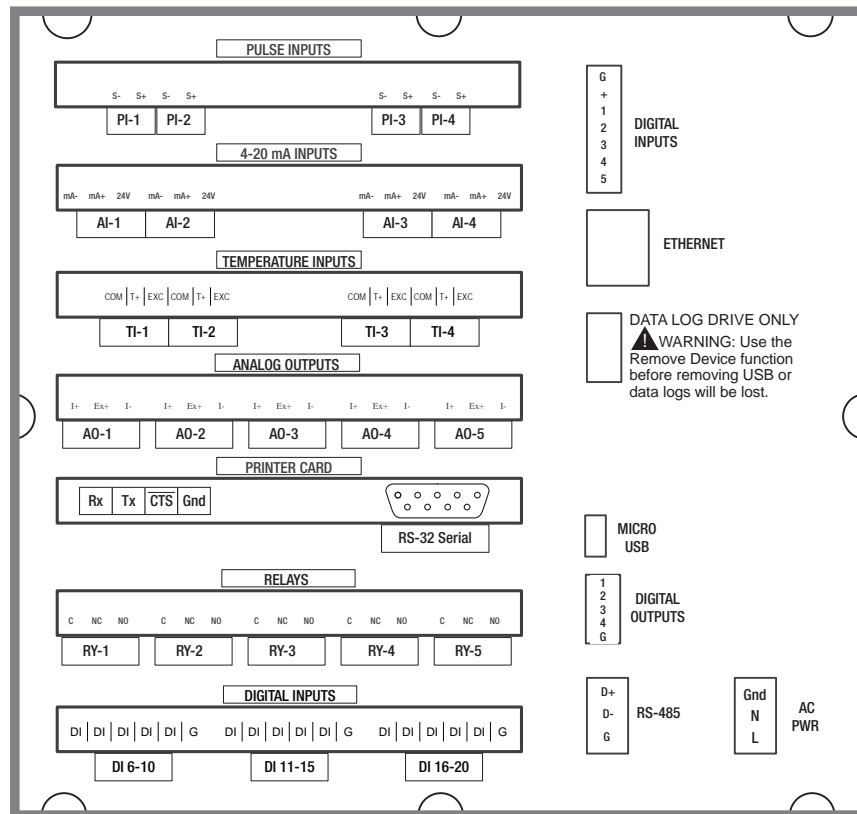

Connection Terminals for a PD9000-6N-4PI-4AI-4TI-5AO-5RY-15DI-E-P

Notes:

1. Each 4-20 mA input has its own isolated 24 VDC power supply to power the transmitter.
2. Each 4-20 mA output has its own isolated 24 VDC power supply to power the output loop.
3. Each relay is Form C and rated at 10 A.
4. Input / output connections are made to removable screw connectors.
5. Every ConsoliDator+ has five digital inputs standard (additional digital inputs can be obtained by using the 15-Digital Inputs card).
6. Temperature Inputs Card has (4) thermocouple/RTD inputs.
7. Every ConsoliDator+ has four digital outputs.
8. Every ConsoliDator+ has RS-485 with Modbus.
9. Powered from AC or DC, depending on the ordered power option.
10. The Data Log Drive is used for the *Data Logger Add-On feature*.
11. Ethernet with Modbus TCP is an option.
12. Micro USB is used for programming the ConsoliDator+ with Free Software.

SETTING CHANNEL PARAMETERS

What makes the ConsoliDator+ easy to program is its intuitive setup screens. As shown in the first image below, the setup screen allows you to see all the relevant information you need when creating or editing a channel - all on one screen! When creating a new channel, the channel number is auto-generated for you. All you have to do is populate the appropriate fields such as the channel tag name, function, input, and units. Scaling the inputs and outputs, selecting number of decimals, and turning the bargraph on/off and inputting its values are also programmed from this screen. Multiple colors can also be selected for the text, background and bargraphs to customize the look of the display screens. During programming, the soft keys will change based on the screen in place. For instance, pressing the edit key will bring up the letters/numbers keypad and appropriate navigation keys will appear (Shown in the bottom image). See the [PD9000 manual](#) for details on setup and programming.

Auto-Generated Channel #: User-editable to re-order channels

Channel Tag: User editable

Color Pattern Select: Select color for text, background, and bargraph

Function: Applied to input source

Input: Source for channel

Units: Engineering / time or none

Decimals: Number of decimals for PV

Scale: Enter input and output values

Cutoff: PV goes to zero below the cutoff value

Display Bargraph: Display on screen

Bargraph Scale: Set the 0 and 100% values

Soft Keys: Change based on the screen in place

Numbers Keypad Button: pressing this will bring up the numbers keypad

Text / Numbers Input Field

Letter and Numbers Keypad: Used to input text and numbers in text fields

Text Field Editing Buttons

Soft Keys: Change based on the screen in place

The top screenshot shows a channel configuration screen for 'Flow #30'. It includes fields for Channel # (13), Channel Tag (Flow #30), Function (Scale Linear 2-Pt), Input (AI-1. 2a (mA)), Units (Gallons/min), Decimals (0), and a Scale table with input/output values (4.000, 20.000, 0, 30000). It also has a Cutoff field (0 Gallons), a Bargraph checkbox, and a Color Pattern Select (Colors 1). The bottom screenshot shows a similar screen for 'Rate #1' with a Source field (2b (mA)), Units (GAL/r), Decimals (2), and a keypad overlay for text entry.

INDIVIDUAL CHANNEL VIEW

To view the details of any channel, press Menu and then press View – Channel. Select the channel of interest. Navigate through the different items using the navigation keys. A green bar indicates the selected item, press the R-key to step into and see more details about the inputs and outputs related to the channel in view.

In the following examples, the screens show all the parameters associated with Channel 1 including analog input, slot number and its current value, setpoints and status of alarms, and analog output and its mA value. The bargraphs in each of these screens examples represent the current value in gallon units.

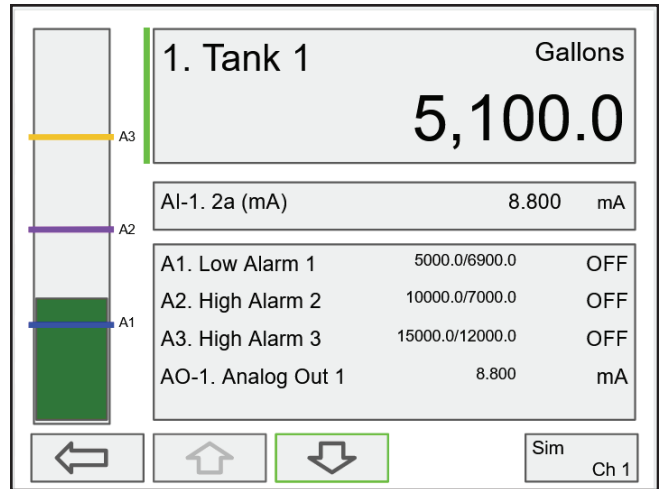

Alarm set points are indicated by horizontal lines.

Low & High Alarm Indication

If applicable, alarms may be acknowledged, and totals may be reset from the channel view screens. The alarm set points are indicated by a line at the corresponding value on the bargraph. Color selection for alarm conditions can be done in the Setup – Alarm menu or in the System – Display menu.

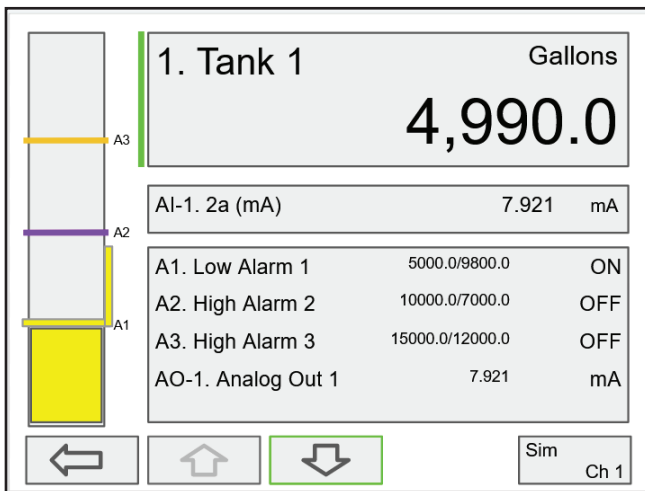

Active Low Alarm: Indicated by horizontal and vertical lines. The top of the vertical line is the reset point of the low alarm. The low alarm is indicated on the right side of the bargraph.

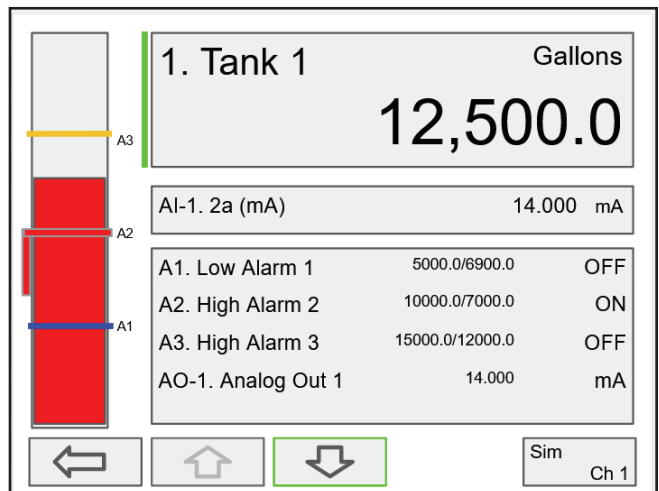

Active High Alarm: Indicated by horizontal and vertical lines. The bottom of the vertical line is the reset point of the high alarm. The high alarm is indicated on the left side of the bargraph.

HOA Screen View

The image on the right shows the screen displaying Tank level in gallons, Alert! message indicating the pump has been turned off manually, HOA switch is the Off position, Pump 1 relay shows the runtime and number of cycles.

The HOA switch can be switched to automatic control by pressing the F3 key (AUTO).

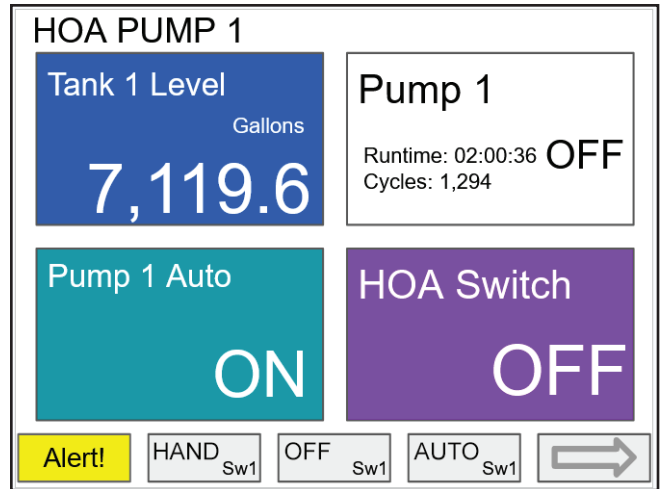

Block Diagram for HOA Switch

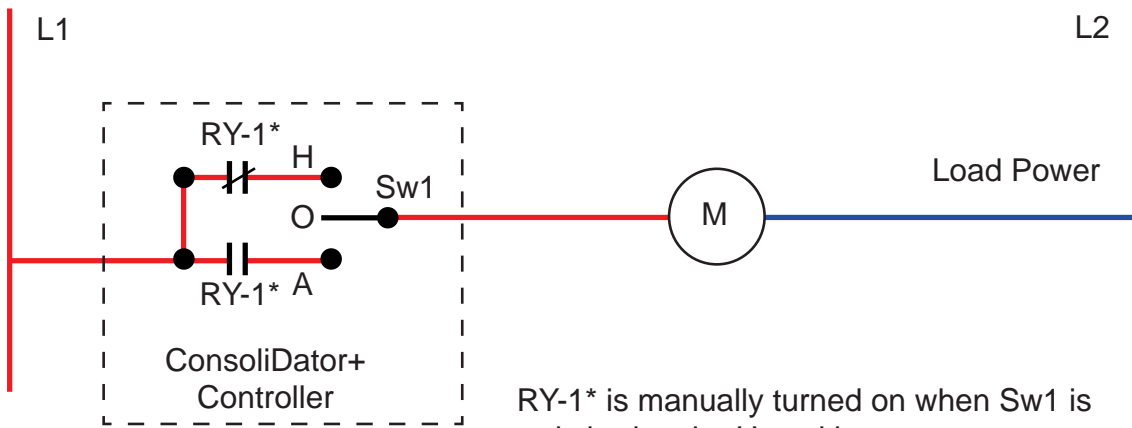

RY-1* is manually turned on when Sw1 is switched to the H position.

FREE CONSOLIDATOR+ CONFIGURATION SOFTWARE



The simplest and fastest way to program the ConsoliDator+ multivariable controller is by using the FREE ConsoliDator+ configuration software. This intuitive software allows most users to set up their controller without needing to consult the manual.

After programming your controller to your specifications, follow the manual's wiring instructions to connect it for your application and proceed with installation. If adjustments are needed post-installation, you can easily modify the programming using the front panel soft keys and the guidance provided in the manual.

See the PD9000 ConsoliDator+ manual for software installation instructions.

Channel Settings

- Enter Display Tag Name for Channel
- Select a Function
- Select Input
- Select Units
- Select Decimal Position
- Select Color Scheme for Text, Background, and Bargraph
- Check Box to Display Bargraph
- Enter Scaling for Bargraph

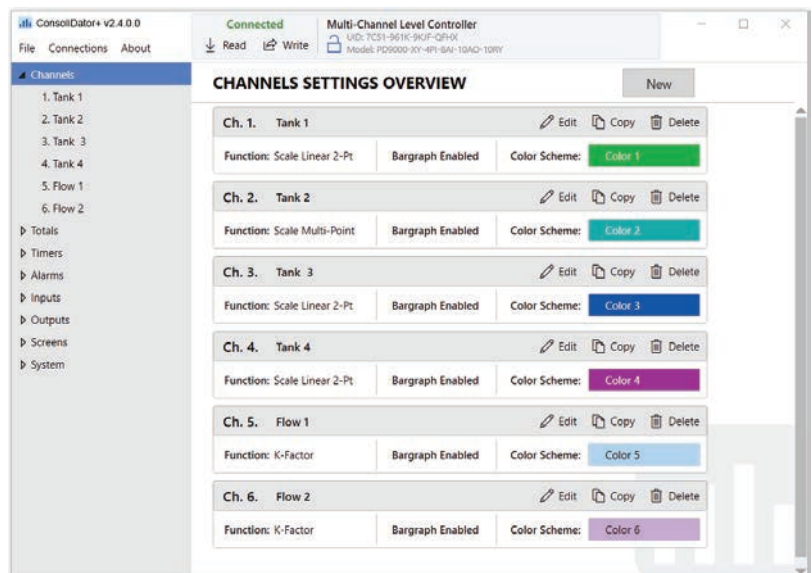

Totals Settings

- Enter Display Tag Name for Total
- Select Input
- Enter Units
- Enter K-Factor Value
- Set Decimal Point
- Check Box for Countdown, Allow Negative, Preset Value and Enter Value, Roll-Over and Enter Value, and Non-Resettable
- Select a Color Scheme for Text, Background, and Bargraph
- Check Box to Display Bargraph
- Enter Scaling for Bargraph

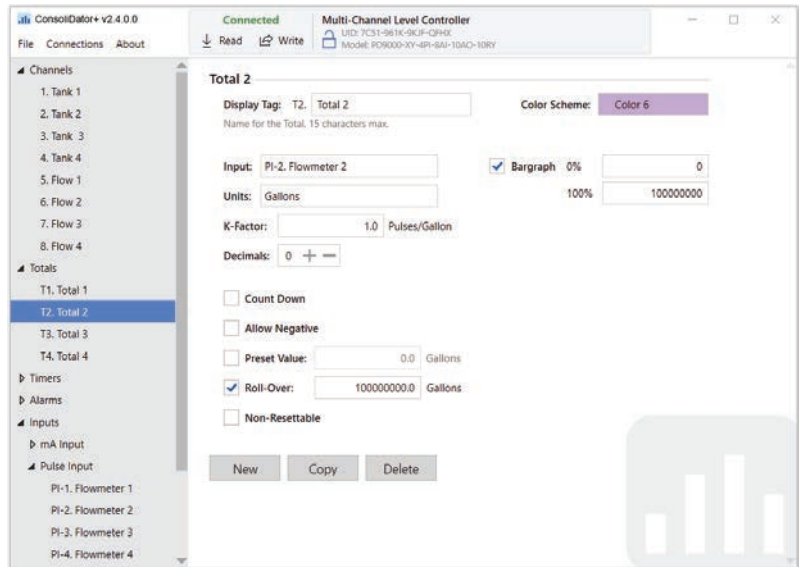

Timers Settings

- Enter Display Tag Name for Timer
- Select Input
- Select Power Up Option
- Select Error Option
- Select Reset Option and Enter Value
- Select Start Option and Enter Value
- Select Stop Option and Enter Value
- Set Decimal Point
- Select Color Scheme for Text, Background, and Bargraph
- Check Box to Display Bargraph
- Set Scaling for Bargraph

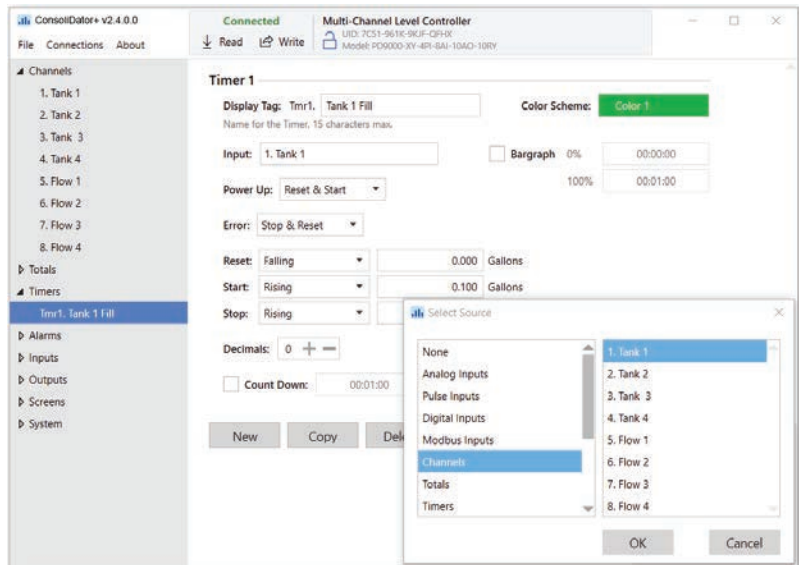

Alarm Settings

- Enter Display Tag Name for Alarm
- Select Alarm Type
- Select Input
- Enter Set and Reset Points
- Select Color Scheme for Text, Background, and Bargraph
- Check Box to turn On/Off Sound Horn, Alert!, Automatic, or Ack Anytime
- Select Break: Alarm Off, Alarm On, Stay As Is
- Enter Value for On Delay and Off Delay
- Enter Name for Alarm Color Profile
- Check Box for Alarm to Flash

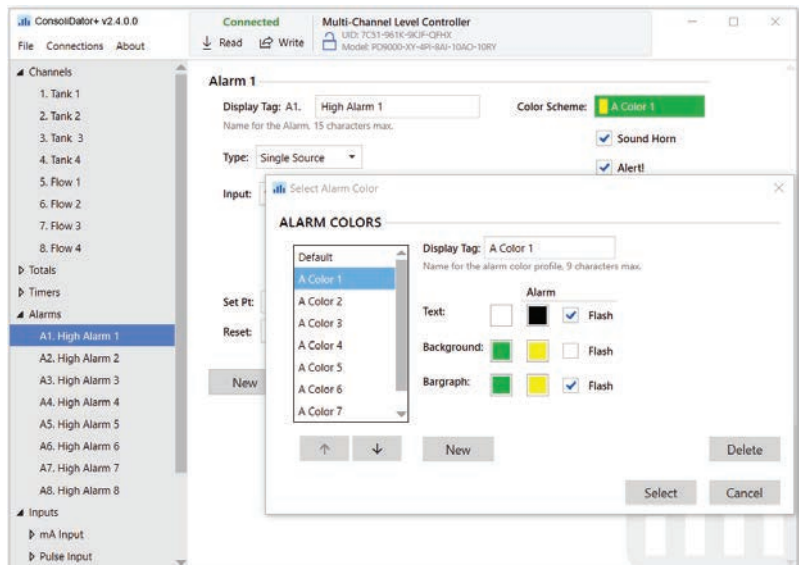

Inputs Settings

- Enter Display Tag Name for Input Channel
- Select Filter Time
- Enter Bypass Value
- Check Box for Glitch Filter
- Check Box for Break Below and Set mA Value
- Check Box to Disable Input Channel

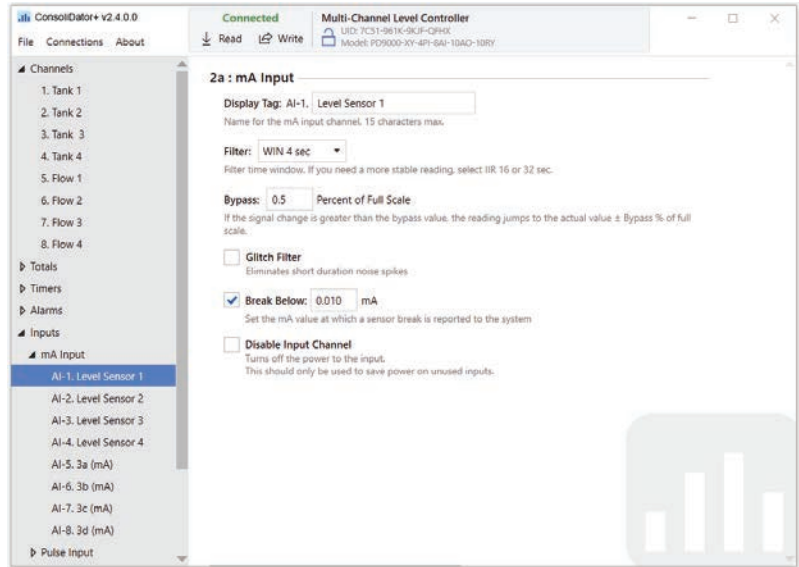

Outputs Settings

- Enter Display Tag Name for Output Channel
- Select Input Source
- Check Box for Fail-Safe

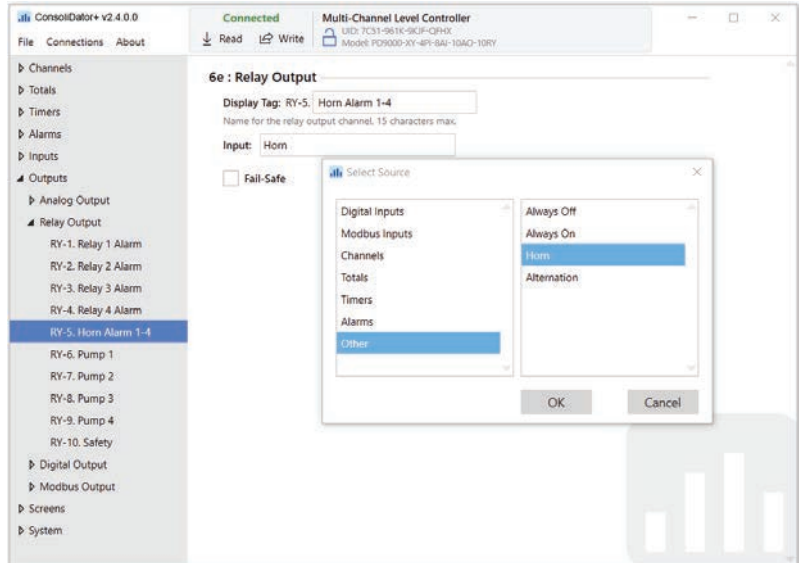

Screens Settings

- Enter Title Name for Screen
- Check Box to Show Title
- Check Box to Show Channel Number
- Check Box to Display Bargraph and/or Bargraph Only
- Check Box to Auto Scan
- Check Box for Dwell Time and Enter Dwell Time

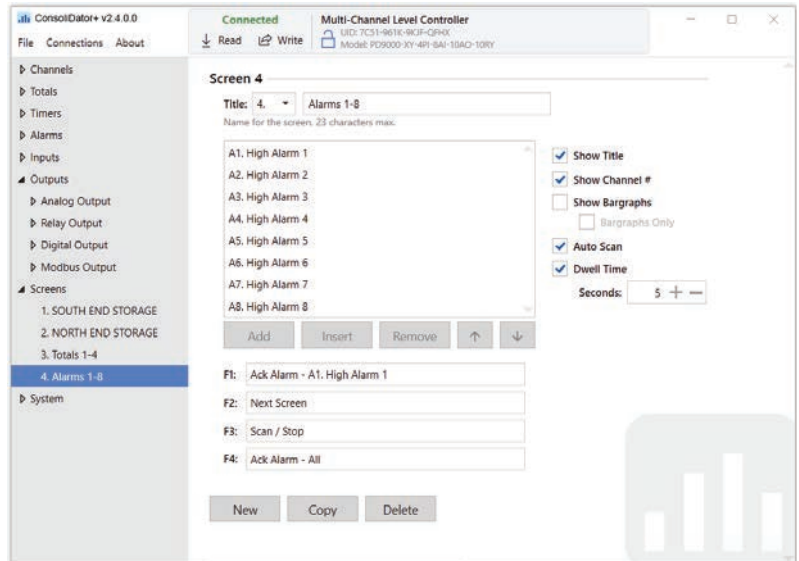

System Display Settings

- Set Backlight Brightness
- Enter Display Refresh Rate
- Check Box to Show Commas
- Select Color Scheme for Text, Background, and Bargraph
- Check Box to Show Alarm Condition Using Alarm Color Settings

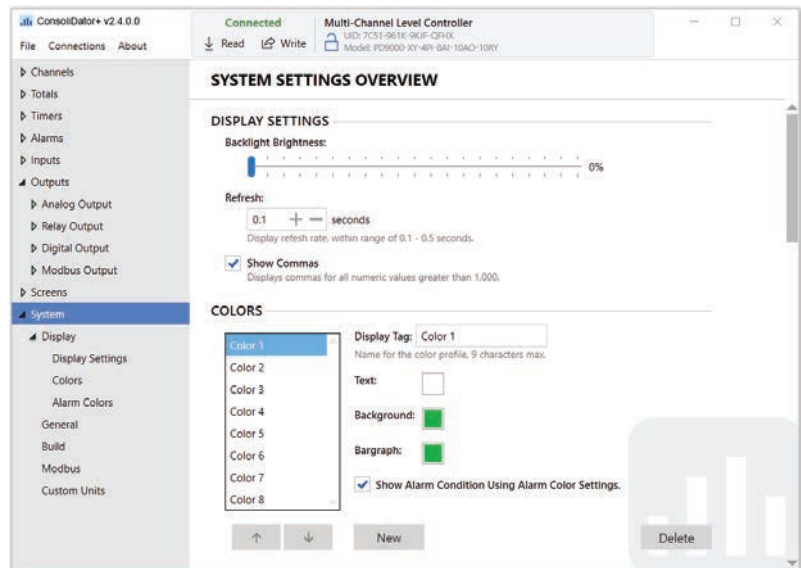

General / Date & Time Settings

- Enter Device Tag Name
- Check Box for Enable Buzzer and Select Buzzer Sound
- Set Date and Time or Check Box to Use System Date and Time
- Click on the Gray Buttons to Load Defaults, Set Password, or Clear Password

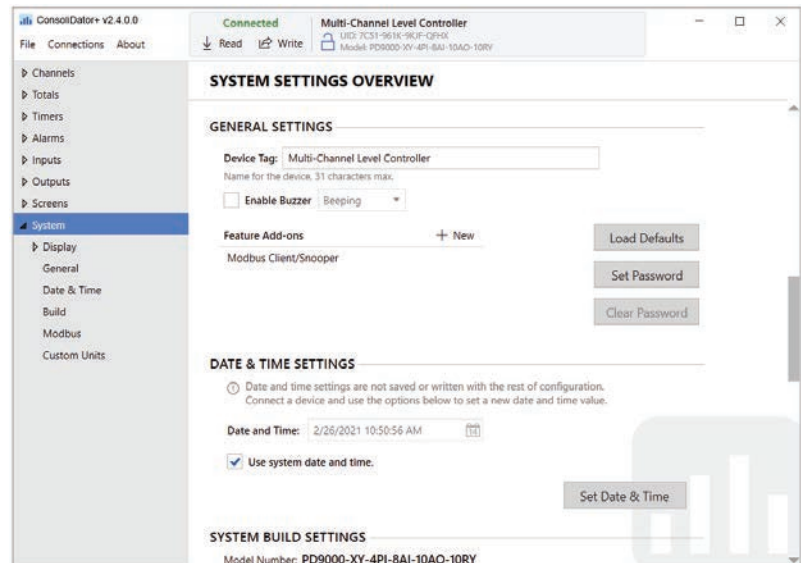

System Build Settings

- Shows Model Number of the Connected Controller
- Shows Slot Numbers and Input/Output Cards Installed on the Connected Controller

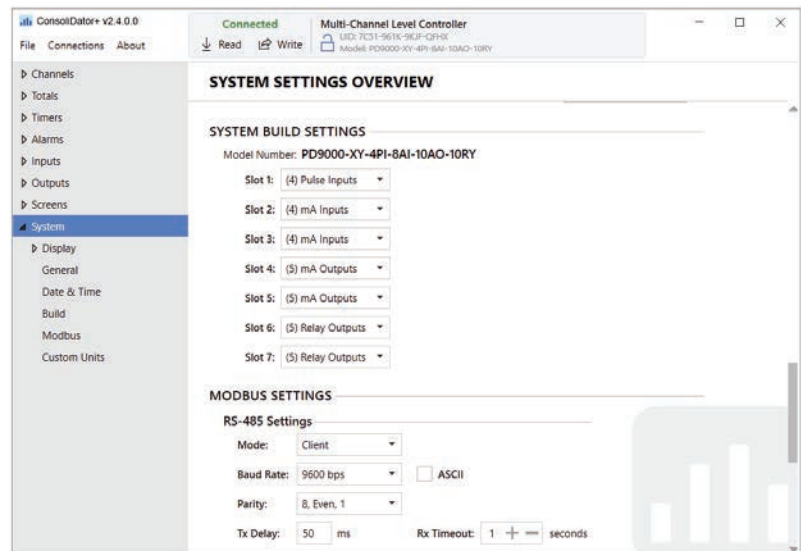

Modbus Settings

- Select Modbus Mode
- Select Baud Rate
- Select Parity
- Enter a Value in ms for Tx Delay
- Click on the Plus or Minus Symbol to Increase or Decrease Seconds for Rx Timeout
- Check the Box for Passcode and Enter a Number to Protect the Server Settings

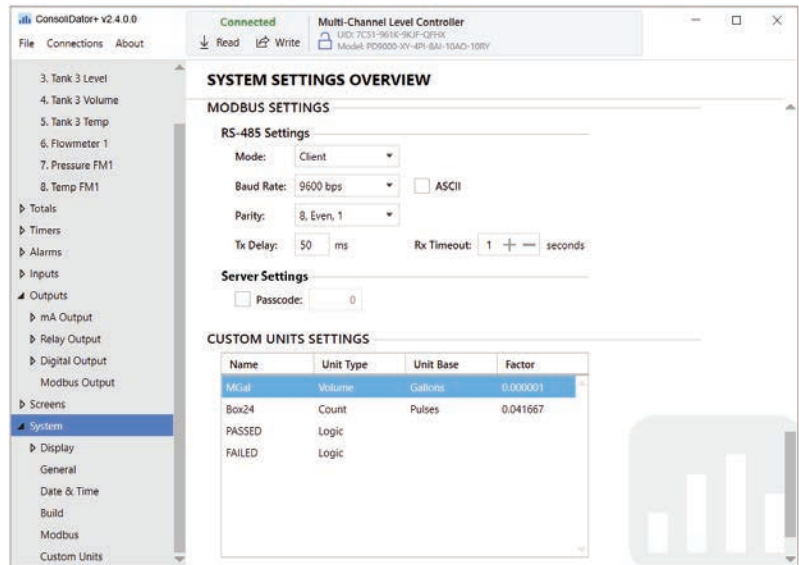

Custom Units Settings

- View or Add Custom Units
- Enter a Label for Unit
- Select a Unit Type
- Select Unit Base
- Enter a Value for Factor

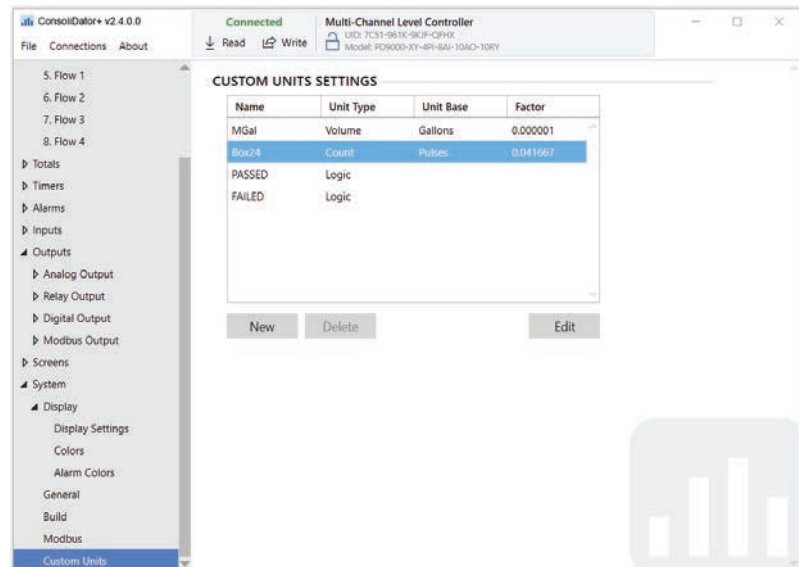

PID Control Settings

- 4-20 mA Output for SCR Control
- Pulse Width Modulation (PWM) for SSR Control
- Heating & Cooling
- Switch Function to Quickly Change Target Set Point
- Switch Function for Easy Auto/Manual Mode Switching with Softkeys
- Enter New Set Points Easily On-Screen with Set Point Softkey
- Initiate Auto-Tune with Auto-Tune Softkey

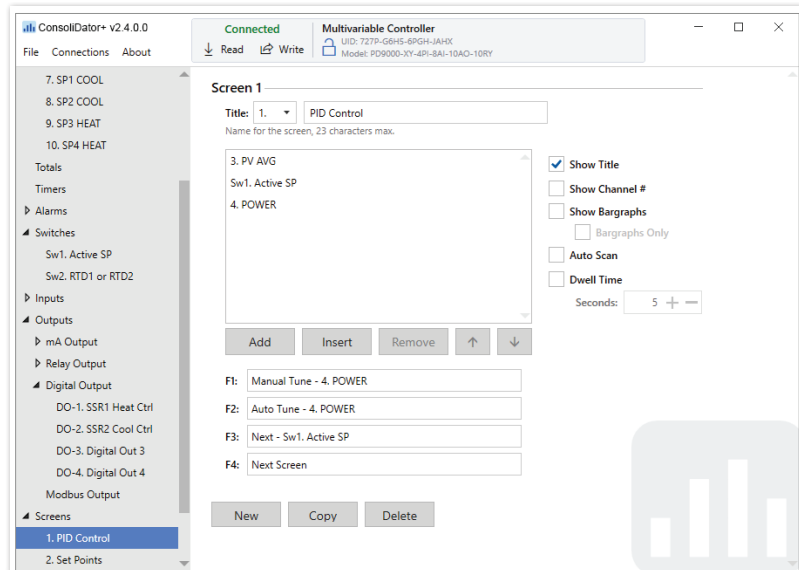

Digital Switch Settings

- Program for Hand-Off-Auto control or PID Output Auto-Manual Switching
- Two, Three, and Four Way Switching
- Each Position Can Reference Any Channel, Input, Output, Total, Etc.
- Unique Name for Each Digital Switch and Switching Position
- Programmable Actions to Execute a Pushbutton Function in Addition to Changing Switch Position

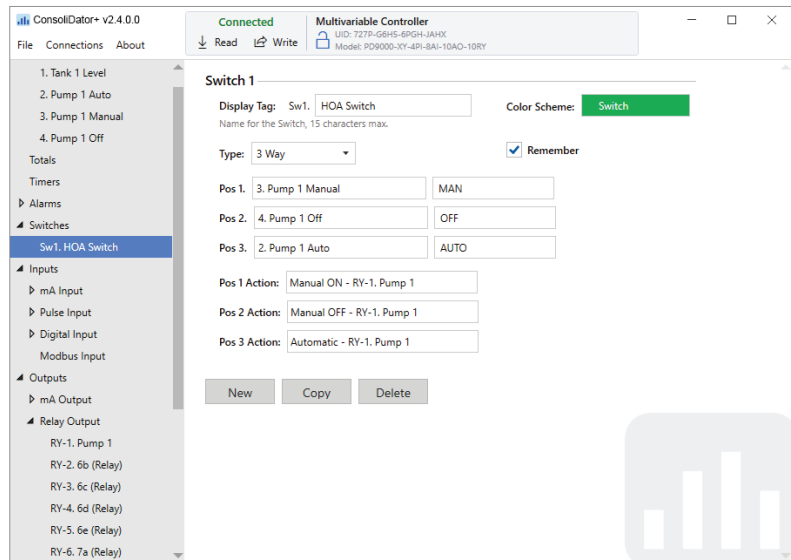

Set Relays to Outputs for Control by Switches

- Select Switch as the Input for the Output
- Switch Positions Determine Output Operation
- Each Position Can Reference Any Channel

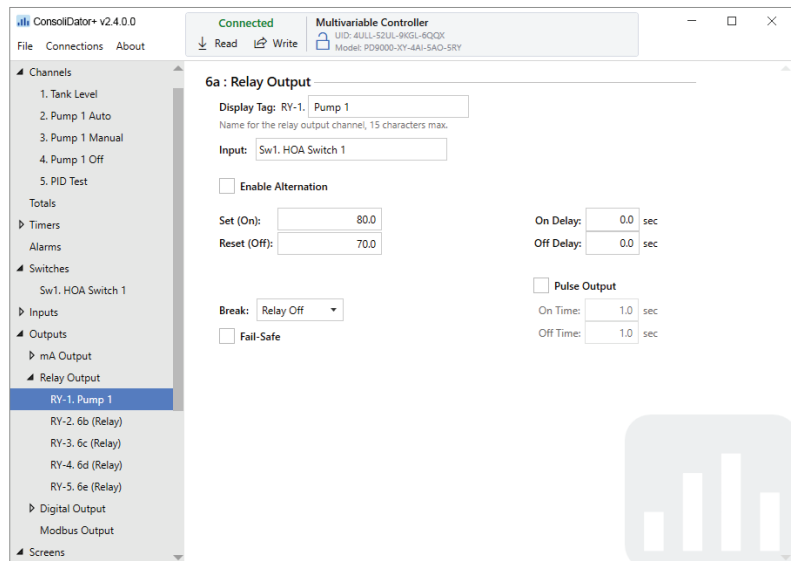

Setup Screens to Operate Digital Switches

- Uses On-Screen Softkeys, No Panel Switches Required
- Set a Specific Softkey to Select Any Single Position on the Digital Switch
- Set a Softkey to Cycle Next or Previous Position
- Display Switch Status on the Screen

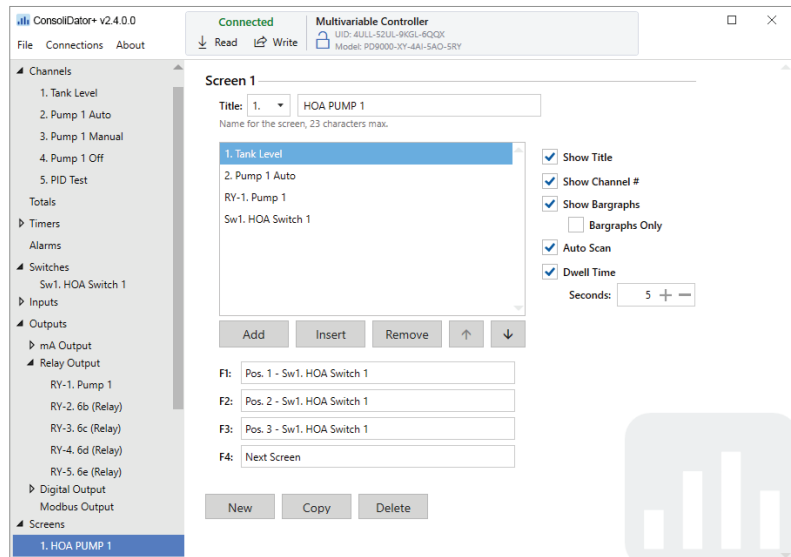

Ticket Printing Setup

- Up to 24 Text Entries can be Configured
- Establish Tab Settings for Printing Various Items on the Same Line
- Select an Appropriate Action After Ticket is Printed or Select No-Action
- Automatically Print Ticket When Batch is Completed
- Manually Print a Ticket At Any Time
- Set Up a Function Key to Print Tickets

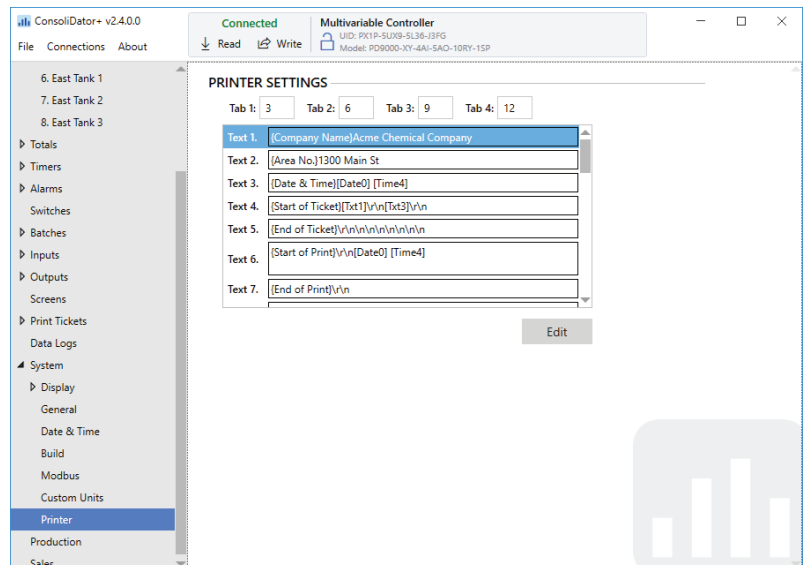
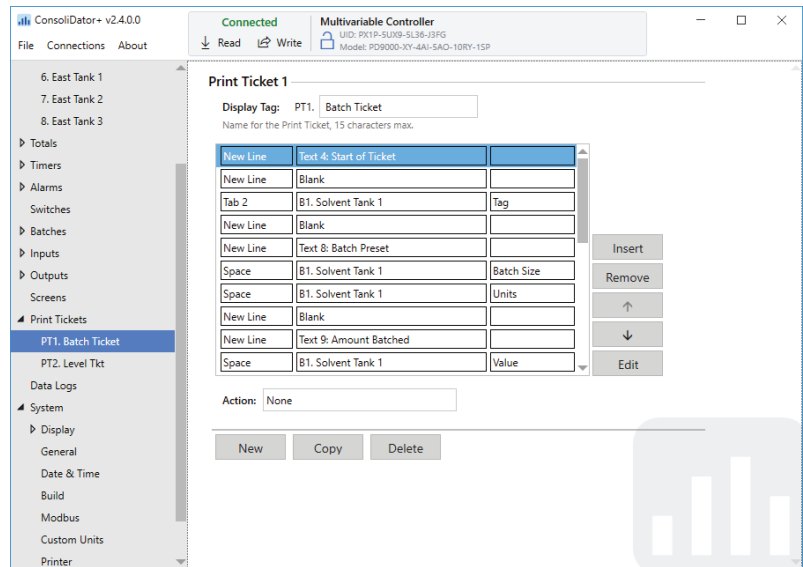

MODBUS CLIENT, SNOOPER & SPOOFER ADD-ON FEATURES

The [PDK9000-M1](#) Modbus Client, Snooper & Spoofer *Add-On Feature*, when ordered with the ConsoliDator+, will be activated at the factory. This Add-On feature can also be ordered for existing ConsoliDator+ units with firmware version 2.1 or greater at any time. The user will receive a key that can be entered into the ConsoliDator+ to unlock the Add-On feature. See the [PD9000 instruction manual](#) on how to enable the *Add-On Features*.

The ConsoliDator+ Multivariable Controller supports Modbus RTU, Modbus ASCII, Enron Modbus, and Ethernet Modbus TCP/IP. The Server mode is a standard ConsoliDator+ feature; it responds to requests and accepts writes from a Modbus client.

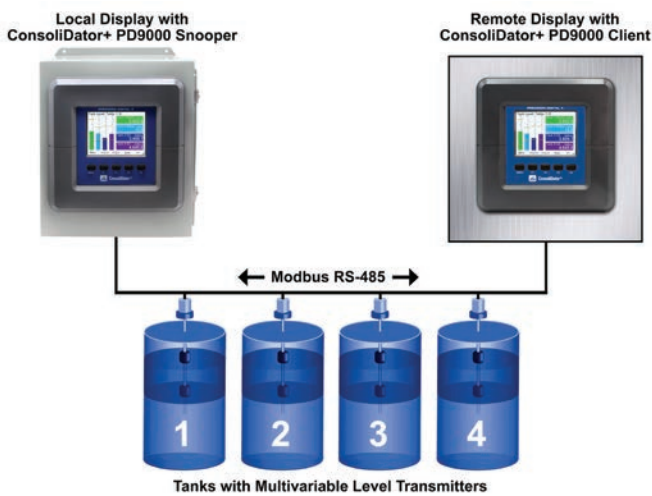

Client Mode

The Client mode can request process variables from server devices; the input variables can be scaled, combined with other variables using math functions, and they can be written to other server devices using the Modbus output functions. The controller can request up to 199 Modbus values, as inputs from other Modbus devices. The inputs can be used as the source for channels, math functions, alarms, relay control, etc.

MB-1.	MB Input 1	Client
Server ID:	247	Address: 0
Function Code:	03	<input type="checkbox"/> Enron
Type:	Float 32	Reg. No. 40001, 40002
Byte Order:	ABCD	
Units:	Gallons/min	Decimals: 2
Break:	Default	Default: 0.00 Gallons/min
<input checked="" type="checkbox"/> Poll Time:	5.0 seconds	<input checked="" type="checkbox"/> Timeout: 00:00:10
Input Action:	Add To T1. Total 1	
Cancel	Home	Save

Snooper Mode

The Snooper mode can listen and read the process variables being transmitted on the RS-485 bus without causing any disruptions to the network. The controller can read up to 199 Modbus values, as inputs from other Modbus devices being polled by a Modbus Client. The inputs can be used as the source for channels, math functions, alarms, relay control, etc.

MB-3.	MB Input 3	Snooper
Server ID:	1	Address: 0
Function Code:	03/06	<input type="checkbox"/> Enron
Type:	Float 32	Reg. No. 40001, 40002
Byte Order:	ABCD	
Units:	Gallons/min	Decimals: 2
Break:	Default	Default: 0.00 Gallons/min
<input checked="" type="checkbox"/> Timeout:	00:00:15	
Input Action:	None	
Cancel	Home	Save

Spoof Mode

The Spoofer mode is designed to replace existing Modbus Servers without requiring changes to the Client configuration. Each process value can be assigned a specific Device ID and Register Number to mimic the original server configuration.

MO-1.	MB Output 1	Spoof
Input:	Total 1	
Server ID:	9	Address: 0
Function Code:	03	<input checked="" type="checkbox"/> Enron
Type:	Float 64	
Byte Order:	ABCD	
Units:	Gallons	Decimals: 1
Output Action:	Reset Total - Total 1	
Cancel	Home	Save

See the PD9000 ConsoliDator+ manual for details on the Modbus Add-On features.

USB DATA LOGGER ADD-ON FEATURE

The [PDK9000-D1 Data Logger Add-On Feature](#), when ordered with the ConsoliDator+, will be activated at the factory. This Add-On feature can also be ordered for existing ConsoliDator+ units with firmware version 2.2 or greater at any time. The user will receive a key that can be entered into the ConsoliDator+ to unlock the Add-On feature. See the PD9000 instruction manual on how to enable the *Add-On Features*.

The PDK9000-D1 Data Logger Add-On Feature for the PD9000 ConsoliDator+ allows you to log data to an external USB flash drive and create logs that contain the same type of process data or a mix of just about anything you might want to log. Each log can contain up to 12 process variables, inputs, outputs, timers, alarm status, relay status or a combination of parameters such as mA inputs, digital inputs, Modbus inputs, channels, totals, timers, and more. The data logger can be controlled in many ways; the start/stop, enable switch, log trigger, or log interval. See the PD9000 instruction manual for more details.

Setup Data Logs

The *Setup Data Logs* menu is used to configure settings that are used for logging data to an external USB flash drive. Any data parameter can be logged; up to 8 data logs can be created. Each data log can contain from 1 to 12 parameters.

Setup New Data Log

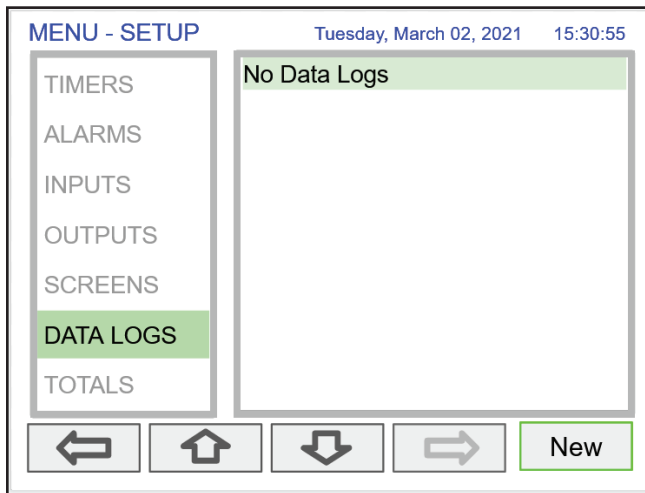

The setup of the data logs is easy, intuitive, and flexible. You can create logs that contain the same type of process data or you can have a mixed of just about anything you might want to log.

- Navigate to the *Data Logs* menu
- Press the *New* key (F4) to create a new log
- An untitled log is created

See the PD9000 ConsoliDator+ manual for details on the Modbus Add-On features.

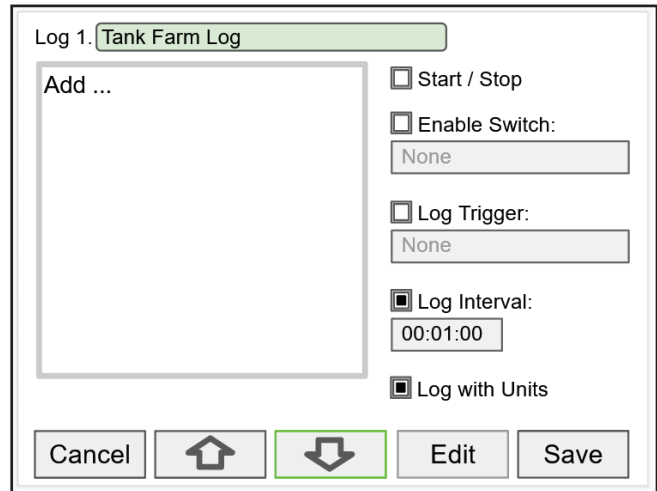

Log #:	Enter log file name
Add:	Add items to be logged
Start / Stop:	Control the log start & stop
Enable Switch:	Select an additional log control
Log Trigger:	Trigger log on a specific event
Log Interval:	Log at the specified interval
Log with Units:	Each log entry will have the corresponding engineering units

CAUTION

- Do not change the units for totals, while the data logger is running; the accumulated total will not be converted to the new units and the reflected value will not be accurate.

Add Items to Be Logged

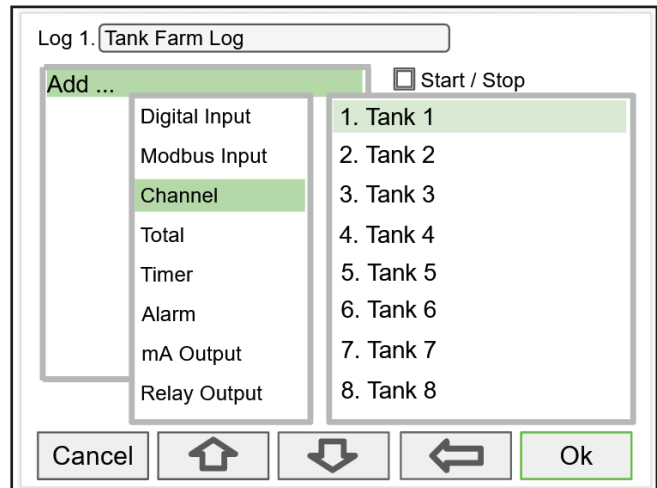

Each log can contain up to 12 process variables, inputs, outputs, timers, alarm status, relay status, or a combination of any of the following parameters:

- | | | |
|-------------------|---------------|---------------------|
| 1. mA Inputs | 5. Totals | 9. Relay Outputs |
| 2. Digital Inputs | 6. Timers | 10. Digital Outputs |
| 3. Modbus Inputs | 7. Alarms | 11. Modbus Outputs |
| 4. Channels | 8. mA Outputs | |

Setup Log Start / Stop

The log *Start / Stop* is used to give the system or the operator control to start and stop the log process. The *Start / Stop* function is available in the View Log menu via the function keys. The *Start / Stop* function can be activated with:

- Screen F1-F4 function keys
- Digital inputs
- Modbus inputs
- Modbus outputs
- Channel Control: Schedule, Sampler

Setup Log Enable Switch

The log *Enable Switch* can be any item with a binary value (on / off, 0 / 1, true / false). Log entries will be made only if the *Enable Switch* is in the on position. The *Enable Switch* input can be:

- Digital input
- Modbus input
- Channel
- Alarm
- Relay Output

Setup Log Trigger

The *Log Trigger* can be any event from the list below. Log entries will be made every time the input is activated. The *Log Trigger* input can be:

- Digital input
- Modbus input
- Channel
- Alarm
- Relay Output

The Modbus outputs can be used to trigger log entries.

Setup Log Interval & Log Units

The *Log Interval* can be from 1 sec to 99:59:59 hh:mm:ss. Log entries will be made at the selected interval. In this example the log must be started, and the digital input 1 must be on to log the tanks volume every minute. To log continuously without the need to start or enable the log, deselect the *Start / Stop* and the *Enable Switch* settings. If engineering units are not needed, deselect the *Log with Units* setting.

CAUTION

- If *Start / Stop* is enabled, the log will stop on a power cycle. Make sure to monitor if the power is turned off and re-start the log when the power is turned on.

Setup USB Drive

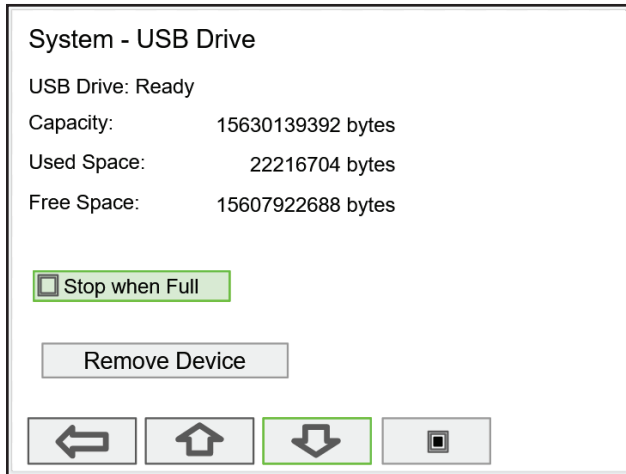

The *System – USB Drive* provides status information about the connected flash drive.

- USB Drive Status
- Capacity
- Used Space
- Free Space

Stop when Full: This should be selected, if the oldest logged data is more important than logging new data.

If *Stop when Full* is not selected, the oldest block of data will be deleted to make room for new data.

IMPORTANT

- The USB Drive menu is available only through the front panel.

Safely Remove Flash Drive

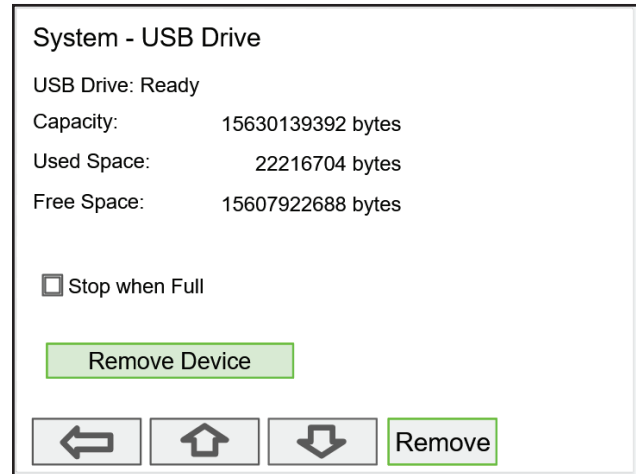

To safely remove the flash drive:

Go to the *System – USB Drive* screen, navigate to the *Remove Device* button using the down arrow key, then press the Remove key.

This procedure allows the USB drive to finish writing any log data in progress and prevent the lost or corruption of data.

View Data Logs

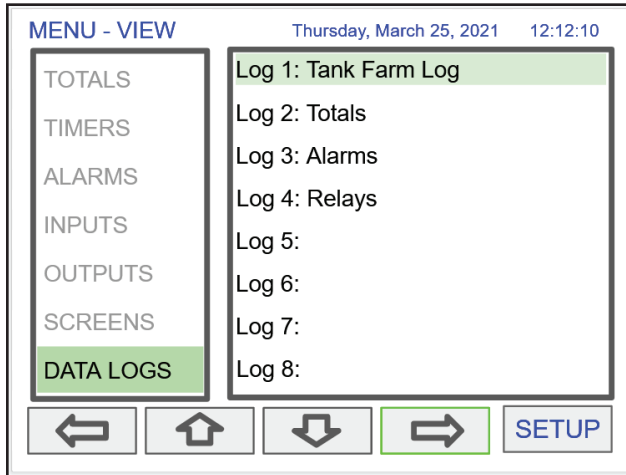

In the *View Data Logs* menu you can see a list of the active data logs. Press the right arrow key to go to the log list and to see details of any of the logs.

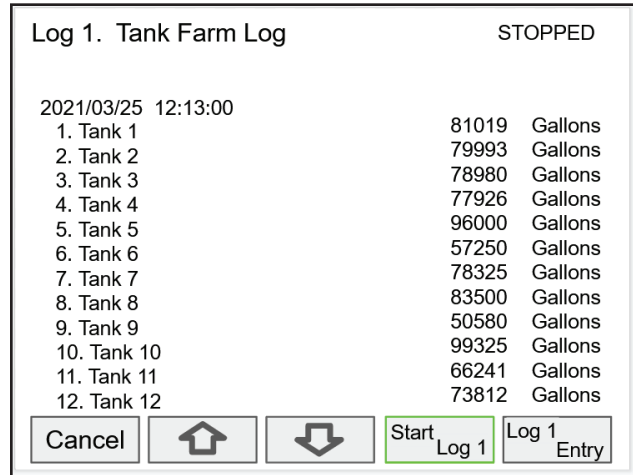

Press the *Stop Log* key to stop logging the selected log.

The *Start / Stop* function can be enabled or disabled during the log setup. This function is independent for each log.

After the log is started, the system will capture the first log according to the log setup selected.

The *Log Entry* key allows the user to capture a snapshot of the process any time.

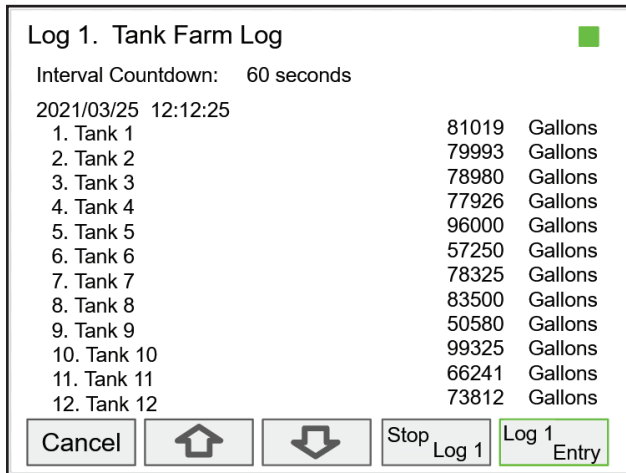

This screen shows a snapshot of the log in progress. If the log is not running, the screen will only show the log # and name. Press *Start Log* followed by *Log Entry* to capture the first log.

IMPORTANT

- There is no provision for viewing previous log records on the screen. The flash drive must be removed and connected to a computer to download the saved logs.

BATCH CONTROLLER ADD-ON FEATURE

The [PDK9000-B1](#) Batch Controller *Add-On Feature*, when ordered with the ConsoliDator+, will be activated at the factory. This Add-On feature can also be ordered for existing ConsoliDator+ units with firmware version 2.4 or greater at any time. The user will receive a key that can be entered into the ConsoliDator+ to unlock the Add-On feature. See the PD9000 instruction manual on how to enable the *Add-On Features*.

The PDK9000-B1 Batch Controller Add-On Feature for the PD9000 ConsoliDator+ enables single-stage or two-stage batch processing, with options for manual or automatic operation. Users can configure up to 16 batches, running them simultaneously or sequentially. During the batch process, various actions can be selected to control lights and horns, providing operators with crucial process information. In addition, a custom ticket can be printed at the end of the batch.

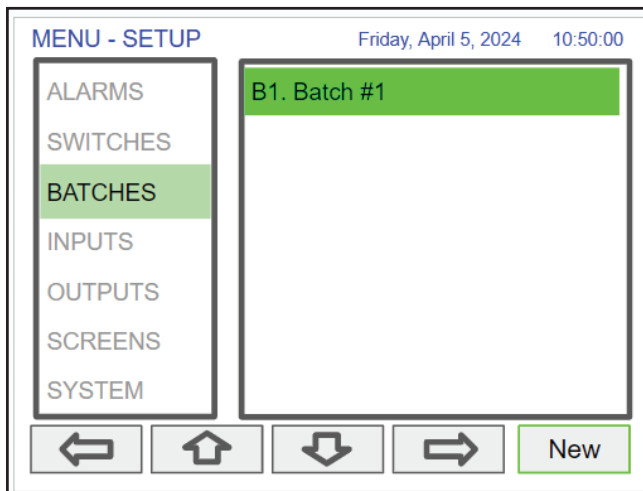
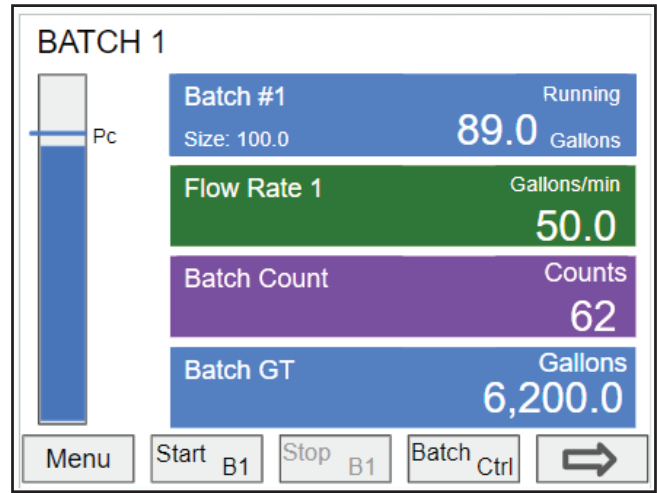

The *Setup Batches* screen is used to configure the batch controller, assigning a user-defined tag, preset and pre-close values.

Batch Controller Features and Functions

- Enter a custom tag
- Select color for text, background, and bargraph
- Select Batch Input
- Enter Preset value
- Select Pre-close, if required
- Select Automatic if required, and enter the time for the Start Delay of the next batch
- Select Auto Correct to make corrections for the next batch
- Select Count Down if required
- Select Actions to be performed during batch operation:
 - Pre-Start Action
 - Start Action
 - Pre-Close Action
 - Finish Action

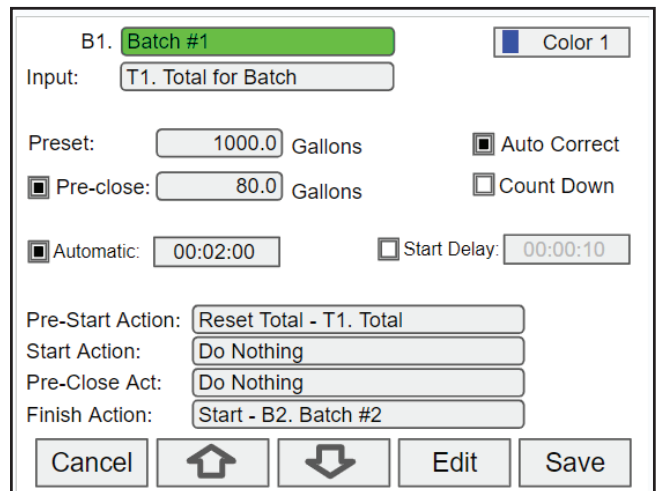

The input for the batch is typically a total. Other process variables, such as channels setup for level, may be selected.

- **Preset:** Target batch size.
- **Auto Correct (default):** If the batch is not equal to the preset, the next batch automatically corrects the difference. It is important to maintain a stable flow rate at the end of the batch for the auto correct to work properly. Depending on the flow rate speed, the first batch might be slightly higher than the preset value.
- **Manual Correction:** Uncheck Auto Correction to require manual batch size corrections. To manually correct a batch, change the preset to adjust for the difference.
- **Pre-close:** Number of volume units prior to reaching the preset value.
- **Count Down:** The batch starts at the preset value and counts down to zero.
- **Automatic:** The next batch begins automatically after the programmed amount of time has elapsed.
- **Finish Action:** Another batch can be started when batch #1 is completed.

CONNECTIONS

CAUTION

- Use copper wire with 60°C or 60/75°C insulation for all line voltage connections. Observe all safety regulations. Electrical wiring should be performed in accordance with all applicable national, state, and local codes to prevent damage to the controller and ensure personnel safety.

Power connections are made to a three-terminal connector for AC (-6) models and to a two-terminal connector for DC (-7) models.

90-264 VAC Power

- Use three-terminal power connector as shown in Figure 1.
- Unit is protected internally with 1.25 A auto-resettable fuse. 2 A max, slow blow, 250 V min UL Recognized external fuse recommended.

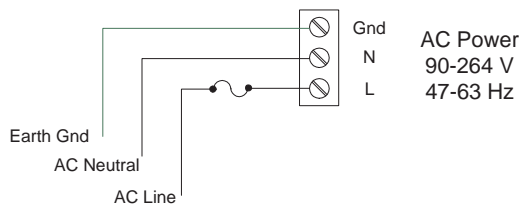

Figure 1. AC Power Connections

24 VDC Power ± 10%

- Use two-terminal power connector as shown in Figure 2.
- Unit is protected internally with 3.7 A auto-resettable fuse. 4 A max, slow blow, 50 V min UL Recognized external fuse recommended.

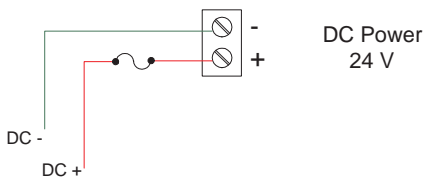

Figure 2. DC Power Connections

Isolated Input Signal Connections

Isolated input signal connections are made to removable screw terminal connectors, which are labeled individually on the back panel of the controller. The back panel shows the type of input card installed in each slot (The top slot is #1 and the bottom is #7). Individual inputs are referenced as PI-1 to PI-4 for pulse inputs and AI-1 to AI-4, AI-5 to AI-8, etc for analog inputs.

4-20 mA Analog Input Connections

Analog 4-20 Input connections are made to screw terminal connectors (two inputs per connector). The following figures show examples for typical applications. Each of the 4-20 mA inputs may be connected in any of the modes shown below.

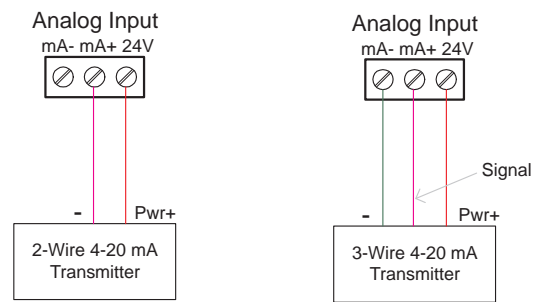

Figure 3. Transmitters Powered by ConsoliDator+'s Isolated 24 VDC Power Supply

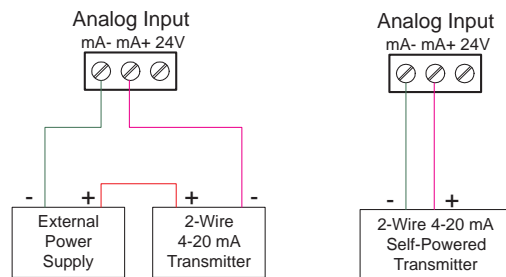

Figure 4. Transmitter Powered by External Supply or Self-Powered

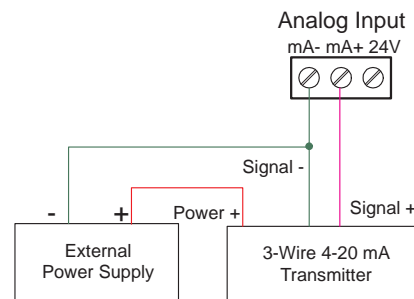

Figure 5. Three-Wire Transmitters Powered Externally

Temperature Input Connections

Temperature Input connections are made to screw terminal connectors (two inputs per connector).

The following figures show examples for thermocouple and RTD connections.

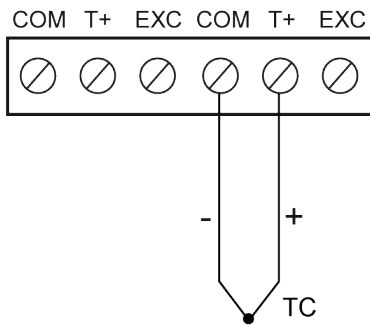

Figure 6. Thermocouple Input Connections

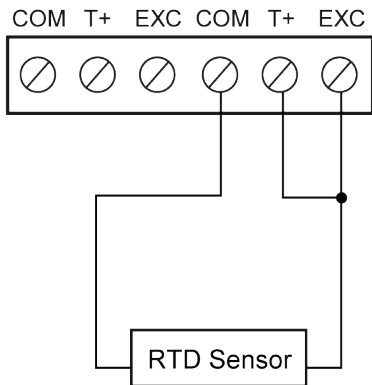

Figure 7. Two-Wire RTD Input Connections

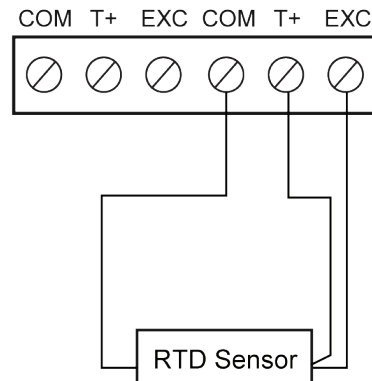

Figure 8. Three-Wire RTD Input Connections

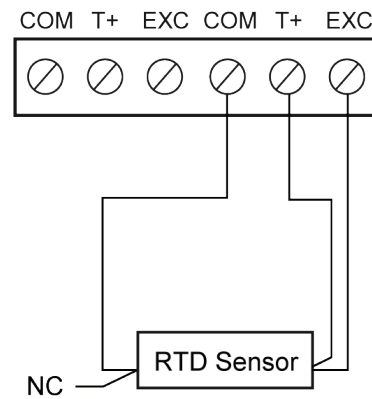

Figure 9. Four-Wire RTD Input Connections

Flow Meter Pulse Input Connections

Flow Meter Pulse Inputs are wired to four-terminal connectors (two inputs per connector). A square waveform is used in the illustration, but the input is capable of reading many other types of signals within the voltage and frequency ranges specified.

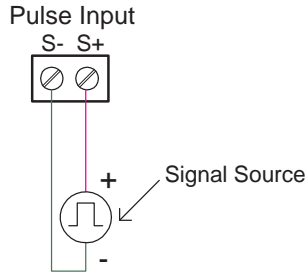

Figure 10. Flow Meter Pulse Input Connections

Digital Input Connections

Five digital inputs are available as a standard feature on the PD9000 and up to seven 15-input digital input cards may be ordered for additional inputs. The five standard digital inputs are wired between terminals 1-5 of the digital input connector and the G terminal of the 2-position connector above the digital inputs. Normally open switch contacts may be used as shown in Figure 7. The diagram also shows a Digital Input using an NPN open collector transistor output from a live signal. Logic LO or switch closure appearing across the terminals is interpreted as ON. When using an open collector transistor, a logic HI at the base (marked "B" in Figure 7) will be interpreted as ON. The 2-position connector has a +5 V terminal that may be used to provide excitation to some sensors requiring more than the pull-up provided on each digital input terminal.

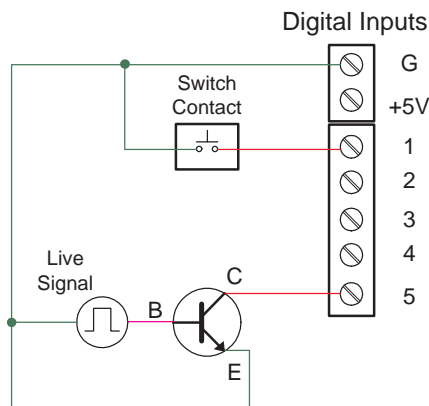

Figure 11. Digital Input from Switch Closure and Live Signal

Analog Output Connections

The following figures show examples for isolated 4-20 mA transmitter output connections. Terminal connectors are labeled individually. The analog outputs are isolated from each other and from the inputs. They are powered internally to provide an active 4-20 mA output loop. The outputs may be powered externally by connecting the positive voltage to the Ex+ terminal.

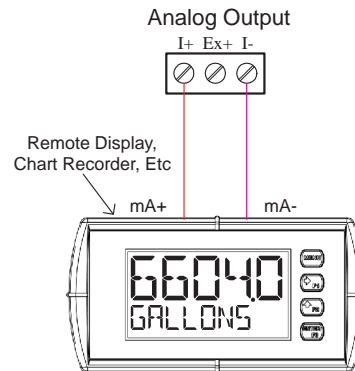

Figure 12. Active 4-20 mA Output Powered by ConsoliDator+

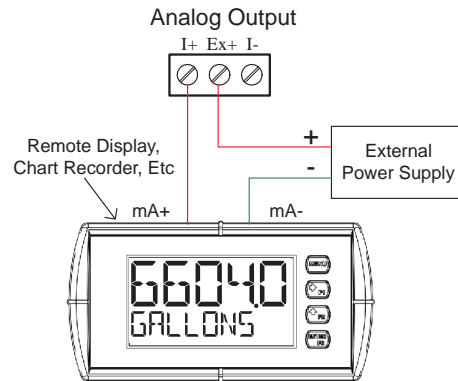

Figure 13. Passive 4-20 mA Output Powered by External Supply

Note: Analog inputs and outputs are isolated from each other.

Digital Output Connections

The digital outputs may be used to drive digital inputs, alarm annunciators, or other devices such as solid state relays that can be driven with low voltage signals.

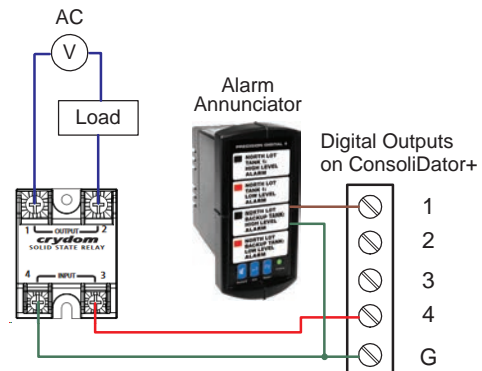

Figure 14. Digital Outputs Driving 5V Solid State Relay and Alarm Annunciator

Connections to Power Gas Detector

Some sensors requiring more than 200 mA of excitation current can be powered by the ConsoliDator+ by connecting two or more power supplies in parallel as shown in the following diagrams.

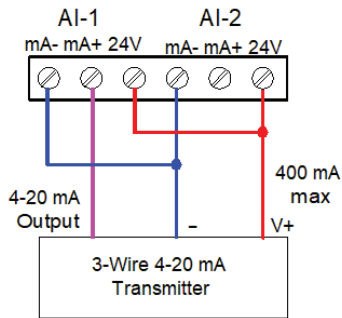

Figure 15. Two Supplies in Parallel Powering 3-Wire Transmitter

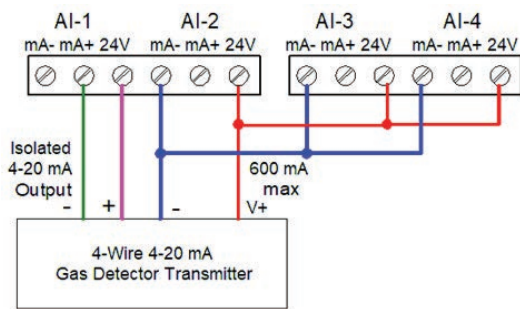

Figure 16. Powering 4-Wire Gas Detector & Isolated 4-20 mA Output

Relay Connections

Relay connections are made to three-terminal connectors labeled individually. There are five relays per card.

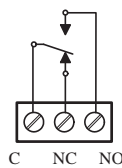

Figure 17. Relay Connections

Switching Inductive Loads

The ConsoliDator+ has internal circuitry to protect the relays from inductive loads, however, the use of suppressors (snubbers) is strongly recommended when switching inductive loads to prevent disrupting the microprocessor's operation. The suppressors also prolong the life of the relay contacts. Suppression can be obtained with resistor-capacitor (RC) networks assembled by the user or purchased as complete assemblies. Refer to the following circuits for RC network assembly and installation.

Note: Because of the built-in RC network, there is the potential for leakage current when driving low power devices such as LEDs or piezoelectric alarms. It is recommended to use external relays to drive the low power devices or request a modification to the relay card from the factory.

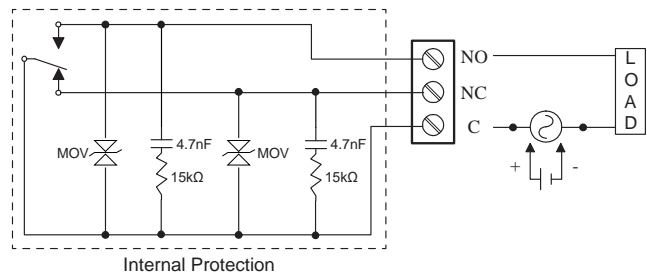

Figure 18. AC and DC Internal Inductive Load Protection

For additional external protection choose R and C as follows:

- R: 0.5 to 1 Ω for each volt across the contacts
- C: 0.5 to 1 μF for each amp through closed contacts

Notes:

1. Use capacitors rated for 250 VAC.
2. RC networks may affect load release time of solenoid loads. Check to confirm proper operation.
3. Install the RC network at the instrument's relay screw terminals. An RC network may also be installed across the load. Experiment for best results.

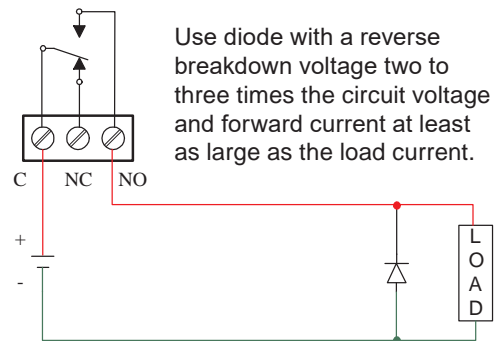

Figure 19. Low Voltage DC Loads Protection

RC Networks Available from Precision Digital

RC networks are available from Precision Digital and should be applied to each relay contact switching an inductive load. Part number: PDX6901.

Serial Communication Connections

The RS-485 port for serial communication (using Modbus protocol) has three terminals labeled D+, D-, and G. It is strongly recommended to use three-wire shielded cable and to always connect the ground terminal to the other equipment's ground to avoid differential voltage between the systems. Distances up to 4000 feet can be reached with RS-485. Up to 32 Modbus devices may be connected to a single RS-485 bus.

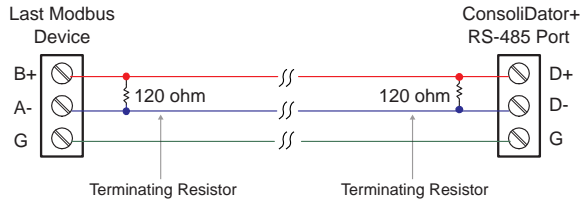

Figure 20. Serial Connections

Ethernet Option

The Ethernet port is available on the RJ45 connector. This allows the ConsoliDator+ to connect to a local area network. The Ethernet port option is configured using the System menu. See the [PD9000 ConsoliDator+ manual](#) for ethernet port setup details.

External Keypad Connections

Normally open pushbuttons may be wired to the digital inputs connector for use when the front panel of the controller is not accessible. The external keys may be assigned to replicate the Menu and F1-F4 function keys.

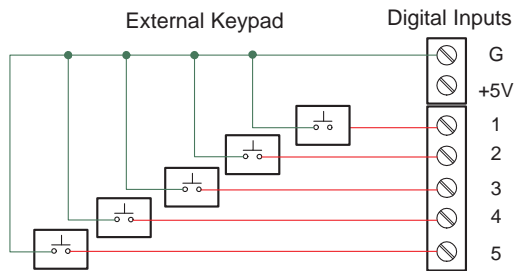

Figure 21. External Keypad Connections

PDA9000-CP Printer Card Connection

The ConsoliDator+ can be equipped with the PDA9000-CP printer card, which installs into any available slot. With a printer card installed, the number of additional I/O cards that can be added is reduced to six. The printer easily connects to the PD9000 with the included DB9M cable.

Note: ConsoliDator+ models equipped with a printer card are not UL Listed, and the printer card occupies one I/O slot.

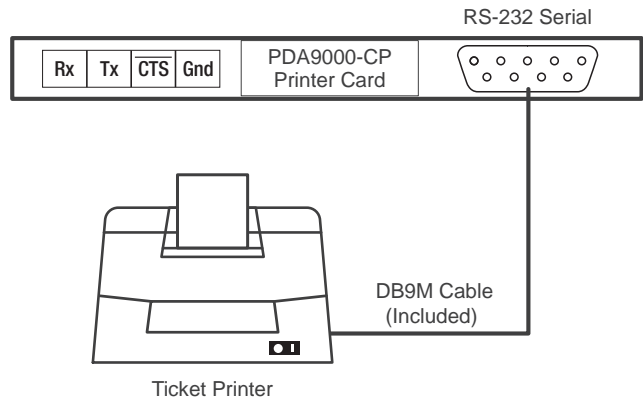

Figure 22. Printer Connections

SPECIFICATIONS

Except where noted all specifications apply to operation at +25°C.

General

Display	Color; QVGA (320 x 240 pixels), 5.7" (145 mm) diagonally, white backlight Bargraph: Twenty divisions Numerical: Up to 15 digits (±999,999,999,999,999) Feet & Inches Format: 99,999' 11.9"	External Horn (Sold Separately)	Assign any relay to the Horn function to activate an external horn when alarm condition is detected.
Screen Bargraph	Enable/disable: Channels, totals, timers Bargraph scale: 0 – 100%, independent of channel scale. Twenty divisions: 5% each. Screen: Select to show bargraph or not.	Live Channel Calibration	Live calibration of channels is independent of the input calibration used for scaling.
Color Selection	65 colors selection Customize bargraph, panel background, and text for normal and alarm conditions.	Input & Output Cards	Max Number of I/O Cards: 7 Analog Inputs: 4/card Pulse Inputs: 4/card Temperature Inputs: 4/card ⁽¹⁾ Digital Inputs: 15/card ⁽¹⁾ Analog Outputs: 5/card Relays: 5/card ⁽³⁾ Printer: 1/card ^{(1) (2)} 1. Models equipped with these cards are not UL Listed. 2. Printer card occupies one I/O slot. 3. Max number of relay cards is 6.
Decimal Point	0 to 15 decimal places, user selectable	Number of Screens	Up to 20 screens with 1 to 8 PVs or items per screen Enable or disable screen title, channel #, and bargraph Automatic or manual scanning Scan time: 1 to >1000 sec, independent for each screen F1-F4 keys are assigned per screen
Engineering Units	User selectable units or custom units Time, Distance, Volume, Pressure, Weight, Temperature, Current, Voltage, Percent, Amps, Volts, Counts, Logic, and Custom, Any unit/unit of time or other units. See page 49 for list of engineering units.	Function Keys	User programmable (See defaults below) F1 = Previous ← F2 = Next → F3 = Scan/Stop F4 = Ack
Feet & Inches Units	Data entry format: Decimal (e.g. 50.58 feet) Display format: 50' 6.96"	Number of Channels	Up to 99 channels Input Source: 4-20 mA, Pulse, Digital, Modbus, another Channel, Total, Timer, Alarm, Date & Time, mA Output, Relay Output, Digital Output, or Modbus Output
Units Conversion	Units' conversion is supported for channels, totals, timers, and any function using those parameters. Channel scaling must be in the intended base units (e.g. Gallons/min)	Channel Functions	There is an extensive number of functions that can be applied to the inputs, see <i>Channel & Math Functions</i> in the instruction manual.
Boot-Up Time	Less than 10 seconds All inputs and outputs	Number of PID Control Channels	Up to (8) PID control loops can be set up with (8) analog inputs and (8) analog outputs. Note: (2) analog input cards and (2) analog output cards are used. The (3) remaining slots can be used for relays.
Display Update Rate	User selectable: 0.1 to 0.5 sec (10 updates/sec to 2 updates/sec)	Programmable Switches	Up to (32) programmable digital switches can be used to route any input, output, or process variable.
Programming Method	Front panel buttons, external buttons, or ConsoliDator+ Software		
Number of Alarms	Up to 64 high or low, Logic AND & OR Automatic (non-latching) or latching On & Off time delays Can be assigned to one or more relays. Note: Alarms are independent from relays.		
Alarm Types	Single Source: One input Multi-Source: Two or more inputs Interval: Enter time interval and On Time Day & Time: Select day of the week & time Alarm OR: Any active input alarm triggers the OR alarm Alarm AND: All alarms must be active to trigger the AND alarm		
Alarm Ack & Reset	Automatic only (Non-latching) Automatic and manual Manual only (Latching) Manual with Ack only after alarm is cleared (Latching with Clear)		
Alarm Indication	1. Bargraph, panel, and text can be set up to change color on alarm 2. Enable internal buzzer 3. Assign external relay to drive a horn		
Internal Buzzer	60 dBA @ 24 inches (61 cm) Enable/disable in System – General menu Associated with alarm Horn setting		

Password	Programmable password restricts modification of programmed settings. View and Setup menus are password protected, function keys and digital inputs are not protected.
Simulation Mode	Inputs, channels, totals, timers, and alarms can be simulated from the View menu or from a function key. Simulation mode is not saved on power down. Alert! message is provided for simulated items.
Manual Control	Analog outputs and relays can be controlled manually from the View menu or from a function key. Manual control mode is not saved on power down. Alert! message is provided for outputs in manual control. Note: <i>If it is necessary to turn relays off and maintain the condition through power cycle, configure the relays to Always Off.</i>
Non-Volatile Memory	Settings stored for a minimum of 10 years
AC Powered Models (-6)	Three-terminal connector (L, N, GND) 90-264 VAC, 47 to 63 Hz, 60 W max
DC Powered Models (-7)	Two-terminal connector (G, 24V) 24 VDC \pm 10%, 60 W max Means of Protection: Class 2 (Reinforced) Overvoltage Category: Class II
Fuse	Units are protected internally with auto-resettable fuse AC: 1.25 A max DC: 3.7 A max
External Fuse	Recommended external fuse slow-blow 120 VAC: 2.0 A 240 VAC: 1.0 A 24 VDC: 4 A
Isolation & Grounding	1500 V Analog inputs/outputs-to-power line 500 V Analog input-to-input, input-to-output, analog output-to-output All analog inputs and analog outputs are isolated from each other.
Environmental	Operating temperature range: -25 to 55°C (-13 to 131°F)* Storage temperature range: -40 to 60°C (-40 to 140°F) Relative humidity: 0 to 90% non-condensing
Front Sealing	Type 4X, IP66
Pollution Degree	2
Maximum Altitude	2000 m (6,562 feet)
Internal Fan	Automatic temperature-controlled fan turns on if the inside temperature reaches 50°C and increases the speed as the temperature rises to 60°C.
Internal Heater	Automatic temperature-controlled heater located behind the LCD turns on at 0°C, delivering the minimum power. If the temperature drops below -10°C, the heater delivers its maximum power.

Connections	Removable screw terminal blocks Inputs/Outputs: 12 to 24 AWG wire Digital I/O: 16 to 30 AWG RS-485: 12 to 24 AWG wire RJ45 Ethernet connection USB ports: Micro-USB used for programming; cable included. Data Log Drive: Type A, used with Data Logger Add-On feature.
Tightening Torque	Screw terminal connectors: Analog I/O & Relays: 0.5 Nm (4.5 lb-in) Digital I/O terminals: 0.23 Nm (2 lb-in)
Enclosure	Enclosure Body: Thermoplastic Polyester Color: Gray Display Window: Clear Polycarbonate, GE LEXAN HP12W Front Panel Keys: Silicone rubber
Mounting	Panel-mounting frame and twelve screws (provided) Cutout: 10.0" x 10.0" \pm 0.05" (254 mm x 254 mm \pm 1.3 mm) (H x W) Panel thickness: 0.07" – 0.35" (1.8 mm – 8.9 mm) Clearance behind panel: 6" (152 mm)
Overall Dimensions	10.85" x 10.85" x 4.87" (276 mm x 276 mm x 124 mm) (H x W x D)
Weight	Ex: PD9000-XY-4PI-8AI-10AO-10RY 7.4 lb (3.4 kg) approx.
Field Enclosure	This device is an open-type controller and is required to be installed in a suitable enclosure that can only be accessed with the use of a tool or key. Panel mounting fasteners shall be tightened to a torque value of 0.8 Nm (7 lb-in).
Warranty	3 years parts and labor. See Warranty Information and Terms & Conditions on www.predig.com for complete details.

Totalizer

Number of Totalizers	Up to 32 totalizers 15 digits with comma separator
Totalizer Inputs	Calculates total based on selected rate channel, pulse input, digital input, or triggered event for non-rate channels. Total is stored in non-volatile memory if power is lost.
Maximum Total	18 digits 999,999,999,999,999,999
Rate Channel Input	4-20 mA input, Pulse input, Modbus input
Rate & Total Decimal Point	Independent and user selectable from 0 to 15 places
Totalizer Reset	Via front panel keys or digital inputs
Non-Resetable Total	Total can be set up to be non-resetable to prevent unintentional reset. This can be changed in the Setup Totals menu.
Total Units Conversion	Input: Rate channel Total units can be different than rate units. Use the custom units to convert to any unit (e.g. Gallons to Billion gallons BGAL: Factor = 0.000000001)
Pulse Input K-Factor	K-Factor = pulses/units of measure Calculates total directly from pulse input, Modbus input, channel, total, or Modbus output. Create rate channel by entering K-Factor, units and time base in sec, min, hr, or day. Decimals: 0 to 15
Count Down	Total can set up to count down from a predetermined value entered by the user.
Preset Value	Enter the preset value to count up or down. Reset total sets total to the preset value; to reset to zero uncheck the Preset box.
Roll-Over	Enter the value for total to roll-over to 0 Example: Roll-Over = 1,000,000 Total goes to 0 after 1 million
Negative Total	Allow total value to count below 0 for bi directional flow based on rate channel
Total Bargraph	Bargraph can be scaled to represent the expected maximum total
Function Keys	Screen Setup: Assign F1-F4 to Reset Total, Enter Total, Add To, or Remove From Total
Previous Total	This is the total prior to the last reset. Multiple previous totals can be set up by selecting a previous total as the input to a new total. The date & time is captured with the previous total.
Daily Total	This is the total for the day, starting at midnight. Daily total can be the input for previous totals to keep a record of a few days. The date is captured with the previous total.
Grand Total	Uses another total as the input and it is setup as non-resetable
Non-Rate Total	This total takes the input from a non-rate channel, a trigger causes the total to increment, or decrement based on the settings selected (e.g. Input from weight scale added when digital input is triggered).

Batch Controller

Availability	Order Add-On Feature model PDK9000-B1 at any time. (Cons+ firmware version 2.4 and greater) See manual for how to enable Add-On features.
Methods	Automatic or Manual, count up or count down
Auto Correct	Select auto correct to automatically correct minor deviations of the delivered batch from the preset value. Test batches must be run until the correct batch is obtained.
Manual Batch Start	Assign a function key to start the batch
Manual Batch Pause/Stop	Assign a function key to pause or stop the batch. A paused batch can be resumed or stopped.
Batch Start Delay	The start delay applies to manual or automatic batch modes.
Automatic Batching	The batch can be run automatically, where the batches run continuously without operator input, after started.
Automatic Batch Restart Delay	The batch will automatically restart after completion of the last batch and the automatic delay. This time is in addition to the start delay, if selected.
Batching Relay Operation	Single or dual-relay batching with optional preclose for dual-stage operation.
Batch Preset	Assign a function key to change the preset quickly without navigating the menu.
Batch Preclose	For two-stage batch application, a preclose value can be set to close the main flow line before the preset is reached.
Pre-Start Action	Select what happens before the batch starts running (e.g. Turn on a horn/light to alert the operator).
Start Action	Select action when batch starts.
Pre-Close Action	Select action when pre-close is reached.
Finish Action	Select action when the batch is completed.
Batch View Screen	The batch view screen provides information about the batch setup (inputs & outputs) and the batch control functions (e.g. Start/Stop, Print, Partial, Force On).
Batch Control	The control functions can be accessed from the View menu or a function key.
Partial Batch	A partial batch can be entered to test the system before running a full batch.
Force On/Off	Batch relay(s) can be forced on or off from the View menu or a function key.
Real Time Clock	
Date Format	Month, day, year (e.g. July 16, 2024)
Time Format	24 hour; 00: Midnight hh:mm:ss
Battery	3V, P/N: CR2032 included Battery replacement only with a Panasonic CR2032 Lithium Metal 3V coin cell battery.
Display Date & Time	Displayed on the top line of Setup and View menus, including day of the week.
Screens	Date & Time can be added to any screen.
Channels	Date & Time can be the input to a channel. Display Format: yyyy/mm/dd hh:mm:ss

Channel & Math Functions

Scale Functions	K-Factor	Converts number of pulses to volume or other units
	Scale Factor	Apply multiplier to a channel
	Scale Linear 2-Pt	Scale a channel
	Scale Multi-Point*	Multi-point scaling of a channel
	Scale Square Root	Apply square root to a channel – Differential Pressure from two channels
	Scale Exponent	Apply exponent for weirs and flumes open channel flow calculation
	Round Horizontal Tank	Calculate volume in round horizontal tank with flat ends
	Units Conversion	Convert base units to custom units
	Percent (Bargraph)	% bargraph of any: 4-20 mA input, channel, total, timer, or mA output
	Text (Percent)	Text displayed based on the % input value
Math Functions	Constant	Assign fixed value
	Summation	Add two or more channels
	Difference	Subtract any two channels
	Abs Difference	Difference always positive
	Absolute Value	Convert channel value to positive
	Average	Find the average of channels
	Weighted Average	Assign % weight to two or more channels
	Multiply	Multiply two channels
	Divide	Divide two channels
	Exponent	Set the base and the exponent; both can be constants or variables
	Logarithm	Set the base and the value; both can be constants or variables
	Polynomial	Calculate single variable 5th degree polynomial
	Modulo	Set constants or variables for A mod B
Trigonometry	Sine, cosine, tangent, arc sine, arc cosine, arc tangent. Select the input and angle	
% Efficiency	Calculate input to output efficiency $((A-B)/A)*100\%$	

Open Channel Flow Functions	Parshall Flumes	$Q = K H^n$ Enter constant, head variable, exponent, and units
	V-Notch Weirs	$Q = K H^{2.5}$ Enter constant, head variable, and units
	Cipolletti Weirs	$Q = K L H^{1.5}$ Enter constant, crest length, head variable, and units
	Rectangular Weirs w/o Contractions	$Q = K L H^{1.5}$ Enter constant, crest length, head variable, and units
	Rectangular Weirs with Contractions	$Q = K (L-0.2H) H^{1.5}$ Enter constant, crest length, head variable, and units
Note: Enter K value for $Q = \text{cuFt}/\text{sec}$; select any flow rate units to be displayed or used as input to a totalizer.		

IMPORTANT

*Scale Multi-Point: There is no minimum input span requirement; it is up to the user to make sure the input values are correct.

Additional Functions	Compare
Greatest	Greatest value in a group of channels
Least	Smallest value in a group of channels
Middle of 3	Outputs the middle value of three inputs
Less Than	Calculate True/False if A is less than B
Measure	
Tare	Calculate net value when Tare function is applied via function key
Maximum	Maximum value reached by the process
Minimum	Minimum value reached by the process
Duration	Keep track of time a condition has been present (e.g. high alarm active)
Rate of Change	Calculates how fast a process is changing /sec, /min, /hr, /day
Filter	
Window Average	Enter time to calculate the average
IIR (First Order)	Infinite Impulse Response (slow)
Cutoff	PV = 0 below cutoff Flip Side: 0 above (-)
Limits	Sets PV upper & lower limits.
Round	Round (to nearest) Floor (always down) Ceiling (always up) Less (toward zero) More (away from zero)
Hysteresis	Resists a directional change using a time delay, filters change in the trending direction
Delay	Enter the number of seconds to delay the output
Pulse Filter	Use to filter discrete inputs, set minimum and maximum on/off time in seconds

Additional Functions	Control
Sampler	Trigger relay sample and select sampling time (e.g. Turn relay on for 30 sec every time total increases by 1,000 Gallons)
On-Off Control	Set on & off control based on PV
On-Off Control with Random Varying On/Off Points	Select Randomizer, enter on/off points +/- random variation
On/Off Multi-Set	Calculate On/Off for multiple positions based on a single input and multiple set-points.
Lead Lag Control	Calculate On/Off for multiple positions based on multiple logic inputs. Inputs are True if not zero, otherwise false.
Pump Alternation	Calculate On/Off for multiple positions based on multiple logic inputs. Inputs are True if not zero, otherwise false.
Logic OR, AND, NOT	Calculate logic combinations of multiple inputs. Inputs are True if not zero, otherwise false.
Select A or B	Switch between 2 inputs
Select 1,2,3...	Select 1 from 3 or more inputs, it works as a selector switch
Schedule	Daily or weekly event The available actions depend on the configuration of inputs and outputs.
Capture	Set a trigger event to capture a value in real time
PID Control	Set up channel for PID control
PWM Control	Set up channel for pulse width modulation control to be used with PID control loop
Switch Position	Set up channel to read the digital switch position (0, 1, 2, 3)
Relays	
Cycle Count	Number of relay cycles since reset
Runtime	Relay runtime (ON) hh:mm:ss
Modbus	
Time Since Read	Time since a Modbus client device read a register
Time Since Write	Time since a Modbus client wrote to a register

Additional Functions	Bitwise
Bitwise Constant	Configure numeric constant in Hexadecimal format.
Bitwise Hex	Convert input to Hexadecimal format.
Bit Test	Calculate True/False if a specific bit of the input is set to 1.
Bitwise OR, AND, NOT	Calculate bitwise logical combinations of multiple inputs. Resulting output is a 32-bit Hexadecimal format.
Bitwise RSH, LSH	Convert input to Hexadecimal format, then perform bit shift operation.
Bitwise Map	Convert input to Hexadecimal format, then perform a bit rearrangement based on bit to bit mapping.
Bitwise Count	Convert input to Hexadecimal format, then count the number of bits that are set to 1.
Bitwise First, Last	Convert input to Hexadecimal format. The result is with only the First (Last) bit set, clearing all other bits to zero. Optionally, the result is the position of the First (Last) bit set.

List of Engineering Units

Time	seconds, minutes, hours, days & /sec, /min, /hr, /day
Distance (Height)	cm, m, Inch, Feet, Ft-In, Yard, km, miles, custom
Volume	Gallons, GAL, L, IGAL, M3, BBL, BUSH, cuYD, cuFt, culn, LiBBL, BBBL, HECtL, quarts, pints, fl oz, mL, DT, M/T, MGAL, custom
Pressure	psi, Pa, bar, hPa, kPa, MPa, GPa, inH2O, cmH2O, inHg, mmHg, atm, kg/cm2, kg/m2, mbar, Mbar, Torr, mTorr, custom
Weight	grams, Oz, Lb, lb, g, kg, ounces, tons, tonnes, custom
Temperature	C, F, K, Ra
Percent	%, PCT, Percent, custom
Amps	mA, Amps, custom
Volts	V, mV, Volts, custom
Counts	Pulses, Cycles, Counts, custom
Logic	ON, OFF, OPEN, CLOSED, YES, NO, START, RUNNING, STOP, STOPPED, PUMP ON, PUMP OFF, OK, OKAY, ERROR, WARNING, custom
Custom	Enter unit's name, type, base unit, and factor.

Pump Controller

Control Modes	Channels > Control 1. On-Off control 2. Multi-Setpoint control 3. Alternation control 4. Lead-Lag control
Inputs	1. On-Off control channels 2. Digital inputs 3. Modbus inputs
Relays	Any relay can be set up for pump control. It is critical to select the corresponding position for the relay to operate correctly.
Number of Alternation Pumps	Limited only by the number of available relays
On & Off Delays	Delays can be added either in the control channels or the individual relays. The delays help to prevent turning on/off multiple pumps at the same time.
Pump Controller Panel	Use channels to monitor the state of the relays and use the screens to create a pump controller annunciator panel.

Refer to *Pump Controller Setup* in the PD9000 manual for setup of the pump controller functions.

4-20 mA Analog Inputs

Number of Inputs	(4) Analog inputs/card (28) Analog inputs max, no other I/O
Typical Input	4-20 mA
Input Range	0-24 mA
Accuracy	±0.03% of full scale ±1 count
4-20 mA Display Value	Up to six recommended ±999,999 More digits can be used, but the stability will be affected. Increase the filter value and lower the display update rate or use rounding to get a more stable reading.
Number of PID Control Loops	(8) PID control loops can be set up with (8) analog outputs connected to SCRs. Note: (4) digital outputs can be used to control SSR (Solid State Relays). Mechanical relays can be used for slow-process PID control. Contact Tech Support if more than (8) PID loops are needed.
Transmitter Power Supply	Isolated 24 VDC @ 200 mA/input Max current: 1,600 mA (All inputs) (8) Analog Input @ 200 mA max (28) Analog Input @ 20 mA max Available on AC or DC powered units
Temperature Drift	Better than 20 ppm/°C from -40 to 60°C ambient
Filter	Window average: None, 0.5, 1, 2, 4, 8 sec IIR (Infinite Impulse Response): 16, 32 sec Glitch Filter: Discards a single sample caused by high frequency noise
Filter Bypass	0 to 100 % of full scale Filter is ignored, if the signal change is greater than bypass value
Channel Input Scale Function	Scale Linear 2-Point, Scale Multi-Point (2 to 50 points)* Scale Square Root Scale Exponent (Open Channel Flow) Scale Factor Round Horizontal Tank (Volume) Units Conversion (mA Input Reading) Percent Bargraph Text (Percent)
Channel Input Live Calibration	Each channel can be calibrated using live calibration signal from a sensor or a calibrator.
Input Protection	Each 4-20 mA input is protected by an auto-resettable fuse, 30 VDC max. The fuse resets automatically after the fault condition is removed.
Input Impedance	125 Ω typical, including auto-resettable fuse
Hart Transparency	The controller does not interfere with existing HART communications; it displays the 4-20 mA primary variable, and it allows the HART communications to pass through without interruption. The controller is not affected if a HART communicator is connected to the loop. The controller does not display secondary HART variables.
Isolation	1500 V: Input-to-power line 500 V: Input-to-input, input-to-output All analog inputs and analog outputs are isolated from each other.
Normal Mode Rejection	100 dB at 50/60 Hz
Common Mode Rejection	90 dB at 50/60 Hz

Pulse Inputs

Number of Inputs	(4) Pulse inputs/card (28) Pulse inputs max, no other I/O
Input Type	Active Square Wave, NPN, PNP, Reed Switch, Coil (Magnetic Pickup) Normal threshold: 1.2 V (0.8 to 3.0 V) High threshold: 2.5 V (2.0 V to 6.0 V) Coil threshold: 20 mV (Low) or 100 mV (High)
Signal Level	Active Square Wave: 0 to 30 V max Typical: 0 to 5 V Coil: 20 mVp-p to 30 Vp-p (Magnetic Pickup)
Input Impedance	Active, NPN, Reed: 10 kΩ pull-up to 5 V PNP: 10 kΩ pull-down to (S-) Coil: >2 kΩ (20 mV sensitivity), >10 kΩ (100 mV sensitivity)
Isolation	Pulse inputs are not isolated, (S-) terminal is connected to system GND
Input Protection	±36 V, non-isolated
Frequency Response & Signal Level	Active Square Wave 5 V: 0 to 100 kHz Coil (Magnetic Pickup): 0 to 50 kHz Frequency – Signal level (Coil: 20 mV) 20 mVp-p – 100 Hz 100 mVp-p – 10 kHz Frequency – Signal level (Coil: 100 mV) 100 mVp-p – 90 Hz 500 mVp-p – 5 kHz 20 Vp-p – 50 kHz
Minimum Frequency	250 μHz with High Gate = 4,000 sec
Low Gate	1 to 99 sec
High Gate	2 to 4,000 sec (Must be higher than low gate)
Low Speed	100 Hz maximum Used for contact debouncing
Pulse Counter	8,388,607 maximum, used for troubleshooting purposes only
Accuracy	±1 count for K-Factor > 1 or 30 ppm
K-Factor	Programmable pulses/unit of measure with up to 14 decimal resolution
Scale Pulse Input	Scale Linear 2-Point Scale Multi-Point Scaling*: 2 to 50 points Scale Factor Units Conversion
Live Calibration	Pulse input channel can be calibrated using live calibration signal from a sensor.

IMPORTANT

*Scale Multi-Point: There is no minimum input span requirement; it is up to the user to make sure the input values are correct.

Modbus Inputs - Server

Availability	Standard feature
Number of Inputs	199 Modbus RTU or ASCII
Scale Modbus Input	Modbus input can be used as the input for creating channels and totals, the same way the 4-20 mA inputs are used.
Data Type	Bit-Logic Signed/Unsigned: 16 (Short), 32 (Long), 64 (Long-Long) Float 32, Float 64 (Double)
Decimal Point	User selectable
Comm Break & Timeout	Specify what value to hold when a communication break occurs and how long to wait for new data before reporting a break condition.
Input Action	Specify what should happen when new data is written to the input register (e.g. Add to Total 1, Log Entry – All Logs).

Digital Inputs

Digital Inputs	5 Inputs, non-isolated, 30 VDC max Standard feature on all ConsoliDator+ models 15-Digital Inputs Card (Optional) Low: 0 to 1.2 V High: 2.8 to 30.0 V Internal pull-up: 5 kΩ to 5 V Max pulse frequency: 1 kHz @ 5 Vp-p +5 V terminal: Internal pull-up 100 Ω Note: Pulse inputs can be used as digital inputs
Digital Input Types	Normally open switch: External excitation not required (Current: 1 mA) Open collector: 4.1 V open circuit voltage Logic level: 0 to 30 V
Assignment & Operation	Active Low or Active High Functions: Remote front panel button, total functions, timer control, alarm functions, screen navigation, horn functions, reset relay information. Digital inputs can be used as input source for channels, totals, and alarms.
Input Protection	±36 V, non-isolated

Temperature Inputs

Inputs	Thermocouple: J, K, T, E, R, S, B, N, C RTD: 100 Ω platinum (0.00385 & 0.00392 coefficients), 10 Ω copper, 120 Ω nickel, 1000 Ω platinum (0.00385 & 0.00392 coefficients)
Cold Junction Reference	Automatic, fixed, no user calibration needed
Temperature Drift	±2°C maximum from 0 to 55°C ambient temperature ±4°C maximum from -25 to 0°C ambient temperature
Input Impedance	Greater than 100 kΩ
Sensor Break Detection	Open TC or RTD sensor indicated by display break, relays can be programmed to go "On", "Off", or to "Ignore" (Note: Ignore is detected as an upscale condition). Analog output goes to the programmed sensor break value.

Accuracy & Ranges

Type	Range (°F)	Accuracy	Range (°C)	Accuracy
J	-200 to 2000	±1.8°F	-129 to 1093	±1°C
K	-200 to 2400	±1.8°F	-129 to 1316	±1°C
T	-200 to 752	±1.8°F	-129 to 400	±1°C
E	-200 to 1800	±1.8°F	-129 to 982	±1°C
R	-50 to 3000	±3.6°F	-46 to 1649	±2°C
S	-50 to 3000	±3.6°F	-46 to 1649	±2°C
B	752 to 3300	±3.6°F	400 to 1816	±2°C
N	-100 to 2300	±3.6°F	-73 to 1260	±2°C
C	32 to 4100	±3.6°F	0 to 2260	±2°C
10Ω	-328 to 500	±0.2°F	-200 to 260	±0.1°C
100Ω	-328 to 1562	±0.7°F	-200 to 850	±0.4°C
120Ω	-110 to 500	±0.2°F	-79 to 260	±0.1°C
1000Ω	-328 to 900	±0.7°F	-200 to 482	±0.4°C

Digital Outputs

Digital Outputs	4 Outputs Standard feature on all ConsoliDator+ models Low: 0 V (no load), 1.5 V max @ 10 mA sink (External pull-up) High: 5.0 V (no load), 3.5 V @ 10 mA load Maximum current: 30 mA Output impedance: 100 Ω Output protection: 150 mA auto resettable fuse Max frequency: 5 Hz
Digital Output Assignment	Digital outputs require logic units as the input. Input sources: Digital input, Modbus input, channel, alarm, horn, always on, or always off
Output Protection	±36 V, non-isolated

Relays

Number of Relays	(5) Relays/card (30) Relays max with (4) analog or (4) pulse inputs, no other I/O
Rating	SPDT (Form C) Resistive load: Rated 10A @ 120/240 VAC or 8A @ 30 VDC Inductive load: NO contacts: 5A, 1/3 HP, 120 VAC; 30,000 cycles NC contacts: 1/8 HP, 120 VAC; 50,000 cycles Minimum load: 100 mA @ 5 VDC
Maximum Current per Relay & Number of Relays	11 relays or more: 5A @ 120/240 VAC or 30 VDC. Limited due to heat dissipation inside the enclosure.
Isolation	1500 VAC, 50/60 Hz for 1 min between coil and contacts
Deadband	0-100% of full scale, user selectable
Electrical Noise Suppression	TVS diodes & snubbers on all contacts. Recommended additional external snubber: 0.01 µF/470 Ω, 250 VAC (Order: PDX6901)
Assignment & Operation	Any relay can be assigned to any alarm, channel, total, timer, digital input, Modbus input, pump control, batch control, horn, always on, or always off. Multiple relays can be assigned to the same alarm or channel. All relays are programmed independently. High & Low Alarm: Defined by set and reset points in the Alarm menu High or Low Alarm: Assign relay to any alarm or channel for on/off relay control Note: Automatic reset only for channel Multi-Source High or Low Alarm: Assign relay to multi-source alarm to indicate common high or low condition. Pulse Action: Set any relay for pulsing on/off timed relay control. Programmable pulse width (on/off time) and on/off delay. Sampling: Relay must be assigned to channel setup for Sampler function with user-defined total increment and sampling time. Pump Alternation: Any relay can set up to alternate with any relay in the group. Multiple alternation groups can set up.
Acknowledge	Front panel Ack key or digital input acknowledges individual or all alarms; relays associated with acknowledged alarm are turned off.
Alarm Relay	Assign any relay to be driven by any alarm; acknowledging the alarm turns off the relay (non-fail-safe mode).
Time Delay	Programmable on/off delays, 0.0 to 999.9 sec Independent for each relay.
Auto Initialization	When power is applied to the controller, relays will reflect the state of the input to the controller.
Fail-Safe Operation	The relay coil is energized when the process variable is within safe limits and the relay coil is de-energized when the alarm condition exists.

4-20 mA Transmitter Outputs

Number of Analog Outputs	(5) Analog outputs/card (35) Analog outputs max with no other I/O cards (Seven I/O slots)
Output Range	4.00 to 20.00 mA, nominal
Calibration	Factory calibrated for 4-20 mA
Scaling Range	Any process range Reverse scaling allowed
Assignment & Operation	Assign to any analog or pulse input, digital input, Modbus input, channel, total, timer, alarm, or fixed value (none). Note: Multiple 4-20 mA outputs can be assigned to the same input.
Accuracy	±0.03% F.S. ±0.005 mA
Temperature Drift	20 ppm/°C from -40 to 60°C ambient. (Output & Input drifts are separate)
Output Loop Power	Powered by controller: 24 VDC @ 24 mA max or powered externally by 12 to 32 VDC
Output Loop Resistance	Powered by controller: 10 to 600 Ω External 12 VDC: 10 to 200 Ω External 24 VDC: 10 to 600 Ω External 32 VDC: 10 to 1000 Ω
Isolation	1500 V: Output-to-power line 500 V: Output-to-output, output-to-input All analog inputs and analog outputs are isolated from each other.

Timers

Number of Timers	Up to 30
Time Format	hh:mm:ss with 0 decimals selected Seconds with 1 or more decimals
Automatic Actions	Power Up: Timer action on power up Error: Action when an error is detected Reset: Event causes the timer to reset Start: Event triggers the timer to start Stop: Event causes the timer to stop
Start / Stop Reset	The function keys and digital inputs can be used to start, stop, and reset the timers, regardless of the automatic actions selected.
Assignment & Operation	Timers can be triggered, stop, and reset, by rising or falling signals from 4 20 mA input, pulse, digital, Modbus input, channel, total, other timers, alarm, mA output, relay, or Modbus output.
Count Down Timer	Select count down and enter starting time
Timer Alarm	Timer can be used to trigger alarms
Bargraph	Select bargraph during setup and scale the bargraph for 0 – 100% target time
Timer Control	Access timer control via the <i>View Timer</i> menu or assign a function key to timer control in the <i>Screens</i> menu
Timer & Relay	Timer can be assigned to drive relays based on selected set and reset points.

Modbus Outputs - Server

Availability	Standard feature
Data Type	Bit-Logic Signed/Unsigned: 16 (Short), 32 (Long), 64 (Long-Long) Float 32, Float 64 (Double)
Register Numbers	The register numbers are automatically generated based on the Modbus output number and the output's data type. Bit – Logic: 04101 – 04199 Signed/Unsigned 16: 44101 – 44199 Signed/Unsigned 32: 44201 – 44398 Signed/Unsigned 64: 45001 – 45396 Float 32: 44401 - 44598 Float 64: 44601 - 44996
Engineering Units	Select the engineering units for the process variable assigned to the output
Decimal Point	User selectable. For short and long integers this is a multiplier applied to the input value, but it is not displayed on the server's screen. The Modbus client uses this setting to read the correct value from the server. Example: Ch 1 value = 4,379.26 MB Output Data Type: Signed 32 Decimals = 0 → Output = 4,379 Decimals = 3 → Output = 4,379,260
Output Action	Specify what should happen when the output register is read by the client (e.g. Start timer 1, Log Entry – All Logs).

Printer Card

Part Number	PDA9000-CP
Cable Connection	DB9M - 10 ft DB9F to DB25M Null Modem Cable (Included with printer card)
Screw Terminal Connection	5.0 mm pitch (Rx, Tx, /CTS, GND) Note: Use only one of the connection methods.
Test Printing	Prints system information, including details on installed I/O cards and firmware versions.
Data Printing	Includes batch ticket printing, event logs (such as alarms and time), and other critical data.
Text Formatting	Allows up to 24 text entries with four tab settings for aligning different items on the same line.
Printer Functions	Allows for printing of a custom ticket using data pulled from various sources (such as channels, inputs, outputs, etc). Tickets can be printed manually using function keys or digital inputs, as well as automatically via programmed trigger events.

Notes:

1. Printer card output uses an RS-232 serial connection.
2. ConsoliDator+ models equipped with a printer card are not UL Listed.
3. Printer card occupies one I/O slot.

Modbus Serial Communications

Compatibility	RS-485 (EIA-485)
Protocols	Modbus RTU or Modbus ASCII Modbus Enron is supported by the Client and the Spoofer modes.
Device Address	1 to 247 (Server)
Transmit Delay	0 to 999 ms
Receive Timeout	1 to 9 seconds
Baud Rate	1,200 to 115,200 bps
Data	8 bit (1 start bit, 1 stop bit)
Parity	Even, Odd, None with 1 stop bit, or None with 2 stop bits
Modbus Inputs	199 for all mode
Modbus Outputs	99 for all modes. The outputs can be grouped together to be sent as blocks of registers. These Modbus outputs are in addition to the outputs listed in the Modbus Register Tables, see PD9000 instruction manual.
Communication Break	Reports a break condition after the response timeout has elapsed. The break condition can be: Zero, a default value, or the text Break. The Client goes into break condition after the server device fails to respond and the timeout has elapsed. The Snooper and Server modes go into break condition after no new data is received within the response timeout window. Alarms can be programmed to go on, off, or stay as is when a break condition is detected. The analog outputs can set up to generate a fixed mA current when a break condition is detected.

Modbus Client, Snooper & Spoofer

Add-On Feature PDK9000-M1	The Modbus Client, Snooper & Spoofer Add-On Feature is an option in the ConsoliDator+. It can be purchased at the time the order is placed or it can be purchased and enabled at any time. (Cons+ firmware version 2.1 or greater) See manual for how to enable Add-On features.
Modes	Client: Requests data from servers and writes data to servers. Snooper: Listens to the RS-485 network communications and reads the selected registers. Spoofer: A channel is configured to pretend being a device that has been removed from the network. The device ID and register number is used.

Client & Snooper Settings

Availability	Order Add-On Feature model PDK9000-M1 at any time. (Cons+ firmware version 2.1 or greater) See manual for how to enable Add-On features.
Number of Output PVs	99 process variables can be written by the Client mode to Modbus servers. Modbus server inputs and outputs are available over the Ethernet port, in Client mode also.
Server ID	Enter the server ID or address containing the process variables to be read or written by the Client or read by the Snooper.
Function Code	Select which Modbus function code to use for reading the server device or for writing to a server by the ConsoliDator+ Client.
Register Address	0-65,533 (Base 0) Reg. No. 30001-39999, 40001-49999 Reg. No. 300001-365534 or 400001-465534 Specifies which register(s) to read from the server device.
Data Type	Select the data format used by the server device. Bit – Logic (Coil) Signed/Unsigned: 16 (Short, 2 byte) 32 (Long, 4 byte) 64 (Long Long, 8 byte) Float 32 (4 byte), Float 64 (Double, 8 byte)
Byte Order	ABCD, CDAB, BADC, or DCBA (big-endian, swapped, or little-endian)
Client Poll Time	1.0 to 999.9 sec. Time between read commands.
Server Response Timeout	99:59:59 hrs.: Time allowed for the server to respond before the Modbus client generates a communication break condition. The timeout should be greater than the poll time. Server/Snooper mode: Time the Modbus input will wait for new data before going into a break condition. If the timeout is disabled, the last value will remain until a new value is received.

Spoofers Settings

Availability	Order Add-On Feature model PDK9000-M1 at any time. (Cons+ firmware version 2.1 or greater) See manual for how to enable Add-On features.
Number of Output PVs	99 process variables can be replaced by the ConsoliDator+ Spoofer feature.
Number of Input PVs	199 process variables can be written by a client to the Spoofer inputs replacing other Modbus servers.
Server ID	Enter the server ID or address being replaced by the ConsoliDator+ Spoofer.
Function Code	Select the Modbus function code used by the server device.
Register Address	Enter the address 0-65,533 (Base 0) for the process variable of the replaced server.
Data Type	Select the data format used by the server.
Byte Order	Select the byte order ABCD, CDAB, BADC, or DCBA (big-endian, swapped, or little-endian)
Engineering Units	Select the engineering units for the process variable.
Decimals	Enter the number of decimals required.
Output Action	Select an action to be performed by the controller, when the Spoofer output is read by a Modbus client or leave as None.

Data Logger – USB Drive

USB Data Logger Add-On Feature PDK9000-D1	The Data Logger Add-On Feature is an option in the ConsoliDator+. It can be purchased at the time the order is placed or it can be purchased and enabled at any time. (Cons+ firmware version 2.2 or greater) See manual for how to enable Add-On features.
Storage Device	External USB flash drive Format: FAT32 (32 GB maximum) Recommended drive: SanDisk 32GB maximum.
Number of Data Logs	8, maximum
Number of Variables / Log	12, maximum
Number of Log Variables	96 variables, maximum (8 logs x 12 variables / log)
Number of Log Records	The number of records depends on the flash drive size. Examples for 32 GB: 1) 4 logs with 8 variables each 1 min rate: ~160,000,000 records Log time: 60 years 2) 8 logs with 12 variables each 1 min rate: ~70,000,000 records Log time: 16 years
Log File Type	csv (comma separated value)
Maximum Log File Size	100 MB A new file is automatically created when the log file exceeds 100 MB.
Stop when Full	This should be selected if the oldest logged data is more important than logging new data. If <i>Stop when Full</i> is not selected, the oldest block of data will be deleted to make room for new data.
Remove Device	Use the <i>Remove Device</i> button, in the <i>System – USB Drive</i> , to safely remove the USB drive and prevent data corruption.
Alert! Message	An Alert! message is displayed in place of the Menu key if the USB drive is removed.
Start / Stop	Selecting this feature enables the <i>Start / Stop</i> function key in the <i>View – Data Logs</i> menu. The <i>Start / Stop</i> function can be activated using the digital inputs, F1-F4 function keys in the <i>Setup – Screens</i> menu, Channel control schedule, Modbus inputs, and Modbus outputs.
Log Enable Switch	The <i>Enable Switch</i> setting can be used to control the log process using digital inputs, Modbus inputs, Channel control, alarms, or relay outputs. Logs are recorded only if the <i>Enable Switch</i> input is in the active (on) condition.
Log Trigger	The <i>Log Trigger</i> setting is used to log data on a specific event; a log can be triggered using digital inputs, Modbus inputs, Channel control, alarms, relays.
Manual Log	The user can record a log entry at any time by using the F4 key in the <i>View – Logs</i> menu or by assigning a function key in the <i>Setup – Screens</i> menu.
Log Interval	00:00:01 to 23:59:59 hrs:min:sec

How to Enable Add-On Features

To enable the Data Logger features, see *Add-On Features* in the PD9000 instruction manual.

⚠ IMPORTANT

- The USB Data Logger functions are available only if the Add-On feature has been enabled in the System – General Settings, see *Add-On Features* in the PD9000 instruction manual.

Sample Data Log File

Device Tag: Multivariable Controller					
Log Name: Tank Farm Log					
Date	Time	T1. Tank 1 T1. Units	T2. Tank 2 T2. Units	T3. Tank 3 T3. Units	T4. Tank 4 T4. Units
4/8/2021	7:41:07	109690 Gallons	99690 Gallons	89690 Gallons	79690 Gallons
4/8/2021	7:41:10	109691 Gallons	99691 Gallons	89691 Gallons	79691 Gallons
4/8/2021	7:41:11	109692 Gallons	99692 Gallons	89692 Gallons	79692 Gallons
4/8/2021	7:41:12	109693 Gallons	99693 Gallons	89693 Gallons	79693 Gallons
4/8/2021	7:41:13	109694 Gallons	99694 Gallons	89694 Gallons	79694 Gallons
4/8/2021	7:41:14	109695 Gallons	99695 Gallons	89695 Gallons	79695 Gallons
4/8/2021	7:41:15	109696 Gallons	99696 Gallons	89696 Gallons	79696 Gallons
4/8/2021	7:41:16	109697 Gallons	99697 Gallons	89697 Gallons	79697 Gallons
4/8/2021	7:41:17	109698 Gallons	99698 Gallons	89698 Gallons	79698 Gallons
4/8/2021	7:41:18	109699 Gallons	99699 Gallons	89699 Gallons	79699 Gallons
4/8/2021	7:41:19	109700 Gallons	99700 Gallons	89700 Gallons	79700 Gallons
4/8/2021	7:41:20	109701 Gallons	99701 Gallons	89701 Gallons	79701 Gallons
4/8/2021	7:41:21	109702 Gallons	99702 Gallons	89702 Gallons	79702 Gallons
4/8/2021	7:41:22	109703 Gallons	99703 Gallons	89703 Gallons	79703 Gallons
4/8/2021	7:41:23	109704 Gallons	99704 Gallons	89704 Gallons	79704 Gallons
4/8/2021	7:41:24	109705 Gallons	99705 Gallons	89705 Gallons	79705 Gallons
4/8/2021	7:41:25	109706 Gallons	99706 Gallons	89706 Gallons	79706 Gallons
4/8/2021	7:41:26	109707 Gallons	99707 Gallons	89707 Gallons	79707 Gallons
4/8/2021	7:41:27	109708 Gallons	99708 Gallons	89708 Gallons	79708 Gallons
4/8/2021	7:41:28	109709 Gallons	99709 Gallons	89709 Gallons	79709 Gallons
4/8/2021	7:41:29	109710 Gallons	99710 Gallons	89710 Gallons	79710 Gallons
4/8/2021	7:41:30	109711 Gallons	99711 Gallons	89711 Gallons	79711 Gallons
4/8/2021	7:41:31	109712 Gallons	99712 Gallons	89712 Gallons	79712 Gallons
4/8/2021	7:41:32	109713 Gallons	99713 Gallons	89713 Gallons	79713 Gallons
4/8/2021	7:41:33	109714 Gallons	99714 Gallons	89714 Gallons	79714 Gallons

Ethernet Communications

Device	Lantronix Xport-05
Protocol	Modbus TCP/IP (Default) Modbus UDP/IP Modbus RTU Over TCP/IP Modbus RTU Over UDP/IP
Port Settings (Do Not Change)	Protocol: RS-232 Baud Rate: 9600 Data Bits: 8 Flow Control: None Parity: None, Stop Bits: 1
Network Stack	IPv4
Ethernet Mac/Phy	10/100 Mbps
Additional Specifications	Refer to the Lantronix webpage at https://www.lantronix.com/products/xport .
Ethernet Port Configuration	Use the <i>System</i> menu for basic Ethernet configuration or download the Lantronix Device Installer software to fully configure the Ethernet at port https://www.lantronix.com/products/xport . See <i>Ethernet Port Setup</i> in the instruction manual.

ConsoliDator+ Software

System Requirements Windows® 7, 10

Compatibility The software and firmware versions must be matched.

⚠ CAUTION

- Do not write configuration files created using older versions of the firmware and software to controllers with Add-On features enabled (Ver. 2.1 & up). This can create undesirable results, especially with the function keys F1-F4.

Connection Standard USB A to Micro-USB type B (cable included).

Configuration Configure inputs and outputs, channels, totals, timers, alarms, etc.
Configure bargraph and panel colors for normal operation, and colors for alarm indication. Save controller settings file on PC for programming other controllers or to restore settings.

Note: The ConsoliDator+ software version must be used with the corresponding firmware version (e.g. Software v2.2 & Firmware v2.2)

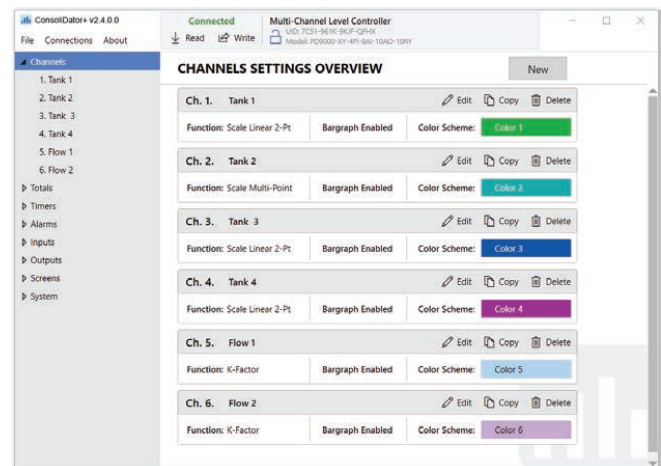

Compliance Information

Hazardous Area Location*

UL & C-UL Listed	For Hazardous Location Installations (US and Canada) Class I Division 2 Groups A, B, C, and D Class II Division 2 Groups F and G Class III Temperature Code: T4A
UL File Number	E516990
Front Panel	UL Type 4X, NEMA 4X, IP66; Panel gasket provided
Low Voltage Directive	CSA-C22.2 No. 61010-1 and CSA-C22.2 No. 61010-2-201 UL 61010-1 and UL 61010-2-201 Safety Requirements for Electrical Equipment for Measurement, Control, and Laboratory Use

WARNINGS

- Explosion Hazard - Batteries must only be changed in an area known to be non-hazardous.
- Explosion Hazard - Do NOT Connect or Disconnect Equipment unless power has been switched off or the area is known to be non-hazardous.

*Hazardous Area Location approvals apply to all PD9000 (H) models. See ordering information.

Note: Models with -TI (Temperature Inputs Card), -DI (Digital Inputs Card), and -P (Printer Card) installed are not UL & C-UL Listed.

Ordinary Location*

UL & C-UL Listed	USA and Canada UL 508 Industrial Control Equipment
UL File Number	E160849
Front Panel	UL Type 4X, NEMA 4X, IP66; Panel gasket provided
Low Voltage Directive	CSA-C22.2 No. 61010-1 and CSA-C22.2 No. 61010-2-201 UL 61010-1 and UL 61010-2-201 Safety Requirements for Electrical Equipment for Measurement, Control, and Laboratory Use

*Ordinary Location approvals apply to all PD9000 (G) models. See ordering information.

Note: Models with -TI (Temperature Inputs Card), -DI (Digital Inputs Card), and -P (Printer Card) installed are not UL & C-UL Listed.

No More Sun Glare On Your Panel Meter Display!

NEW PDA9000SH Sun Hood

The PDA9000SH Stainless Steel Sun Hood improves the readability of the PD9000 ConsoliDator+ Multivariable Controller when it is mounted in direct sunlight by shading the instrument from the sun.

The Sun Hood is made from 18 gauge 316 stainless steel and mounts between the PD9000 controller and the enclosure cover/door.

In addition, the attached gasket is installed between the Sun Hood and the enclosure cover/door to provide a UL Type / NEMA 4X seal. The whole assembly is held in place by the 12 mounting screws provided with the ConsoliDator+ Controller.

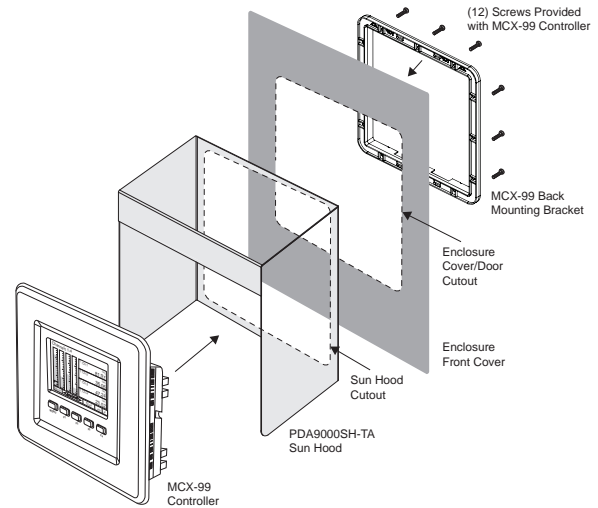

Enclosure and PD9000 Controller Sold Separately.



- Provides Shade for PD9000 ConsoliDator+ Multivariable Controller
- Made from 18 Gauge 316 Stainless Steel
- Easy Mounting Requires no Drilled Holes Enclosure Cover/Door
- Includes Gasket to Maintain UL Type / NEMA 4X Seal
- UL & C-UL Listed

SPECIFICATIONS

Model	PDA9000SH
Material	18 gauge 316 stainless steel
Overall Dimensions	11.04" x 11.08" x 6.15" (280 mm x 281 mm x 155 mm) (H x W x D)
Weight	3.4 lb (1.5 kg)
Gasket Material	Silicone Foam
UL Requirements	For use on a flat surface of a UL Type 4X Enclosure. The 4X sun hood must remain in place in order to maintain the 4X Rating. Installed to 7 lb-in (0.8 Nm).
UL File Number	E548309

CONSOLIDATOR+ ENCLOSURE ASSEMBLY SERVICES



UL
LISTED
Enclosed Industrial
Control Panel

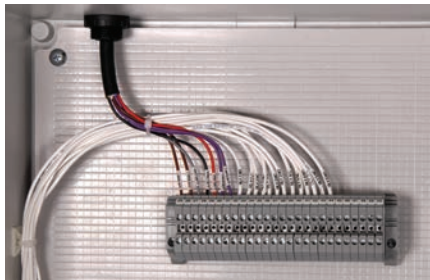

DIN Rail Terminal Strip

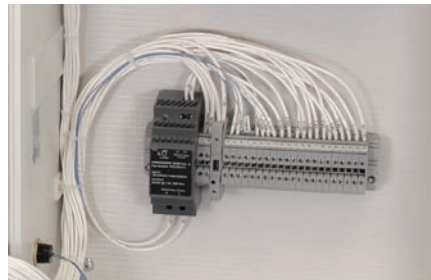

Power Supply & DIN Rail Terminal Strip



Wiring Table Attached Inside

Overview

Precision Digital offers comprehensive enclosure wiring and assembly services for its PD9000 ConsoliDator+ to provide customers with a fully assembled and wired enclosure that is ready to connect to field devices. All enclosure assemblies are certified as UL/C-UL Enclosed Industrial Control Panels.

In addition to installing and wiring the PD9000, other components such as light and horn towers, buttons, power supplies and other devices a customer may want can be installed and wired.

All field wiring is made to DIN rail terminal strips at the base of the enclosure.

Enclosure Assembly Services are available only on the following enclosures: PDA1939, PDA2919, PDA2929, and PDA3939.

Key Features

- Complete Assembly Services with Instruments, Enclosure, Accessories, and Other Components
- Fully Assembled and Wired, Ready for Use
- Includes Backplane and Din Rail Terminal Strips for Connections
- Meticulously Labeled and Professionally Managed Wiring
- Ready for Straightforward On-Site Installation
- Certified as UL/C-UL Enclosed Industrial Control Panels*

*Panels installed with temperature input cards, digital input cards, or printer card are not UL/C-UL panel rated.

 See the PD9000-ENC Data Sheet for More Information and Ordering Details

DIMENSIONS

Overall Dimensions

Units: Inches (mm)

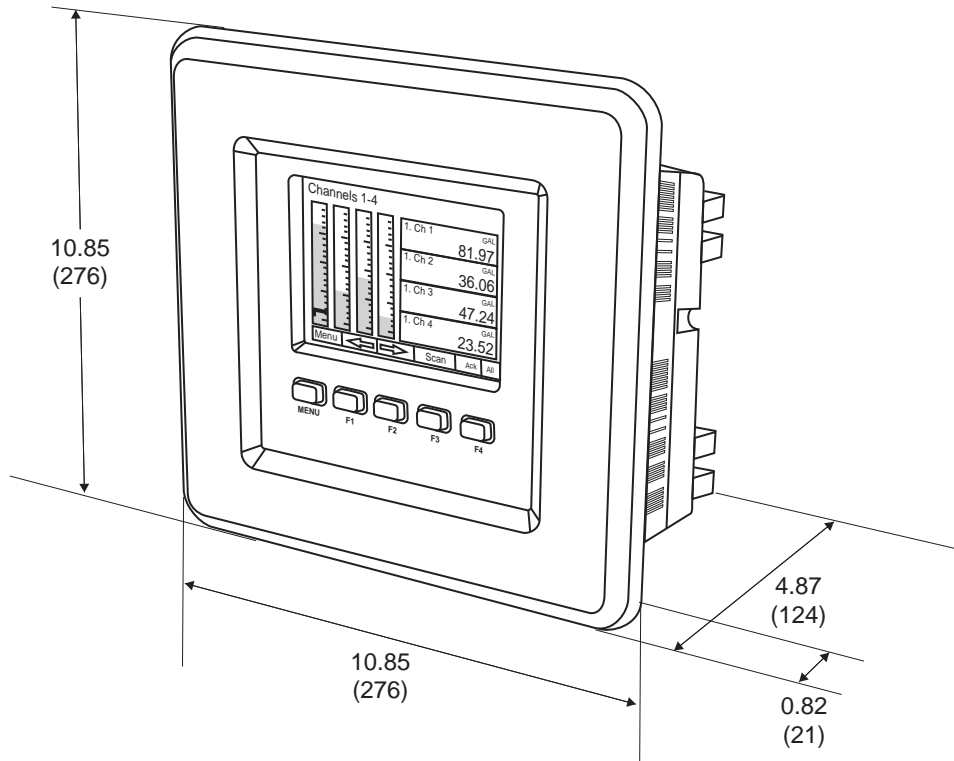

Panel Mount Controller



Download free 3-D CAD files of these instruments to simplify your drawings!

predig.com/documentation-cad

Panel Mounting

- Prepare panel cutout per the dimensions provided
- Locate the panel mounting bracket and screws
- Inspect the controller to assure the gasket is securely in place
- Insert controller in the panel cutout, the latches on the top and bottom should hold it in place
- Insert the panel mounting bracket from the back of the panel, observe the orientation of the piece marked TOP
- Install the 12 screws provided to a torque value of 0.8 Nm (7 lb-in)

Units: Inches (mm)

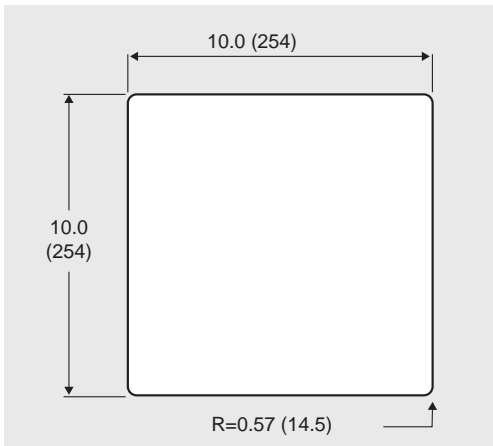

Panel Cutout Dimensions

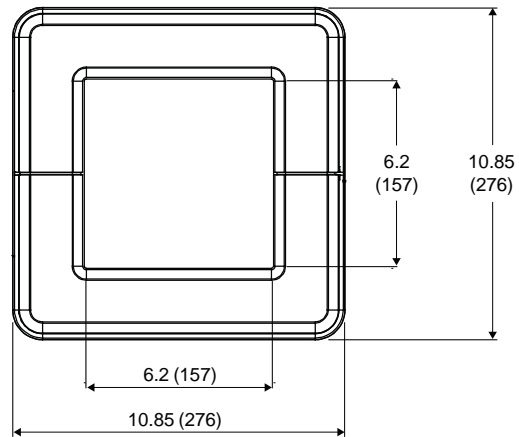

Front Panel Dimensions

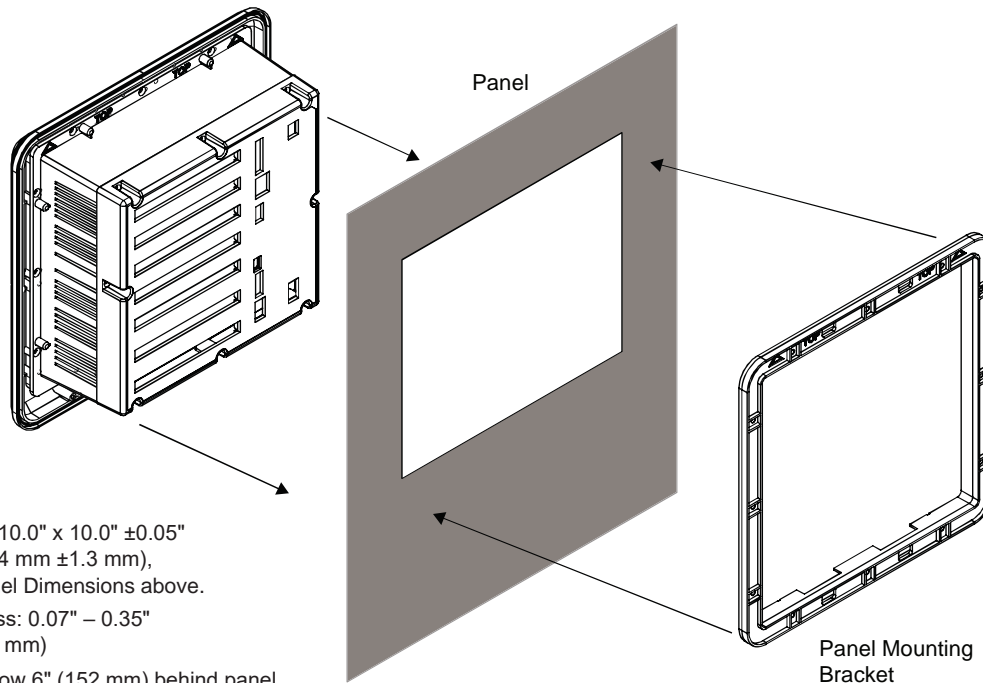

Notes:

1. Panel cutout: 10.0" x 10.0" ± 0.05 " (254 mm x 254 mm ± 1.3 mm), see Front Panel Dimensions above.
2. Panel thickness: 0.07" – 0.35" (1.8 mm – 8.9 mm)
3. Clearance: Allow 6" (152 mm) behind panel

Panel Mount Installation

CONSOLIDATOR+ ENCLOSURES

The PD9000-ENC enclosures provide a convenient way to mount the PD9000 ConsoliDator+ to walls and other vertical structures. The enclosures are available in painted steel and plastic and come pre-cut with one cutout to mount the PD9000. The enclosures are available in various sizes, with the larger enclosures capable of housing other pieces of equipment, such as the PDA1024-01 power supply.

Note: The enclosure and ConsoliDator+ are ordered and packaged separately.

Features

- House One ConsoliDator+ PD9000
- Cutout for One ConsoliDator+ Provided
- ConsoliDator+ Mounts in Cover
- ConsoliDator+ Mounts Inside PDA3939 Clear Cover
- Sub-Panels Available
- PDA6909 Pipe Mounting Kit Available
- Light / Horn & Button Available
- UL Listed Plastic Enclosures
- UL Listed, CSA Certified Steel Enclosures

UL Type 4X / NEMA 4X Plastic Enclosures



PDA1909⁽¹⁾
 Dimensions: 11.8" x 11.8" x 5.9"
 (300 mm x 300 mm x 150 mm)
 (W x H x D)



PDA1939
 Dimensions: 13.8" x 17.7" x 7.9"
 (350 mm x 450 mm x 200 mm)
 (W x H x D)



PDA3939
 Dimensions: 13.8" x 17.7" x 7.9"
 (350 mm x 450 mm x 200 mm)
 (W x H x D)

UL Type 4 / NEMA 4 Steel Enclosures



PDA2909⁽¹⁾
 Dimensions: 12.0" x 12.0" x 6.0"
 (305 mm x 305 mm x 152 mm)
 (W x H x D)



PDA2919
 Dimensions: 12.0" x 14.0" x 8.0"
 (305 mm x 356 mm x 203 mm)
 (W x H x D)



PDA2929
 Dimensions: 14.0" x 16.0" x 10.0"
 (355 mm x 406 mm x 254 mm)
 (W x H x D)

Note:

1. Due to the limited amount of internal space available for these enclosures they are recommended for PD9000s with only a minimal amount of option cards installed.

Download the PD9000-ENC datasheet for more information.



Download free 3-D CAD files of these enclosures to simplify your drawings!

predig.com/documentation-cad

ACCESSORIES

PDA9000SH Sun Hood



PD9000, Enclosure, and Sun Hood All Sold Separately. Assembly required.



PDA9000SH Installed on PD9000 and Mounted in PDA1939 NEMA 4X Plastic Enclosure

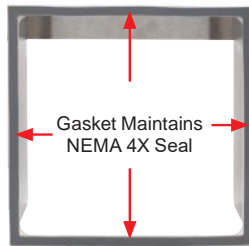

Back View

- Provides Shade for PD9000 ConsoliDator+ Multivariable Controller
- Made from 18 Gauge 316 Stainless Steel
- Easy Mounting Requires no Drilled Holes in the Enclosure Cover/Door
- Includes Gasket to Maintain UL Type / NEMA 4X Seal
- UL and C-UL Listed

The PDA9000SH Stainless Steel Sun Hood improves the readability of the PD9000 ConsoliDator+ Multivariable Controller when it is mounted in direct sunlight by shading the instrument from the sun.

The Sun Hood is made from 18 gauge 316 stainless steel and mounts between the PD9000 controller and the enclosure cover/door.

In addition, the attached gasket is installed between the Sun Hood and the enclosure cover/door to provide a NEMA 4X seal. The whole assembly is held in place by the 12 mounting screws provided with the ConsoliDator+ Controller. See page 58 for Specifications and UL Requirements.

Note: The PDA3939 ConsoliDator+ Enclosure is not compatible with the PDA9000SH

MOD-LH Light/Horn



PD9000, Enclosure, and Light/Horn All Sold Separately. Assembly required.

PD9000 Installed in PDA2919 NEMA 4 Steel Enclosure with MOD-LHRB1 Red Light / Horn and Button

Precision Digital offers the MOD-LH, which includes pre-drilled holes on a ConsoliDator+ enclosure for easy installation of the PDA-LH and PDA-BUTTON accessories.

The Light/Horn is available in three configurations and is designed for mounting in any PD9000-ENC enclosure:

1. **Factory-Ordered Light/Horn:** Available in red, green, yellow, blue, or white.
2. **User-Configurable Light/Horn:** Allows the user to select the light color (red, green, yellow, blue, or white) by connecting the appropriate wire.
3. **3-Layered Light/Horn:** Features independent red, yellow, and green layers that can be activated separately.

The Light/Horn can be wired to flash (not available on PDA-LH5C) or remain steady on, with the horn producing an 85 dB sound. Both the light and horn can be controlled independently via separate relays on the ConsoliDator+, offering various operational modes. For example, the horn can be silenced using the soft keys on the ConsoliDator+ while the light can be reset automatically when the alarm clears.

When ordering the MOD-LH, the enclosure will come with pre-drilled holes for the Light/Horn and Button, and the user will handle the mounting and wiring. The ConsoliDator+ and enclosure are sold separately.

The PDA-LH Light/Horn and PDA-BUTTON can also be purchased separately, with the user responsible for drilling holes, mounting, and wiring as needed.

ORDERING INFORMATION

Required Optional. If none ordered, leave the field blank. Example model entered in gray numbers and letters.

PD9000- **6** **G** - **4** **AI** - **4** **PI** - **5** **AO** - **10** **RY** - **E** - **P**

Enter Number of Analog Inputs

# Inputs	# Cards ²
4	1
8	2
12	3
16	4
20	5
24	6
28	7

Input Type
AI Analog Inputs

Enter Number of Digital Inputs³

# Inputs	# Cards ²
15	1
30	2
45	3
60	4
75	5
90	6
105	7

Input Type
DI Digital Inputs

Enter Number of Pulse Inputs

# Inputs	# Cards ²
4	1
8	2
12	3
16	4
20	5
24	6
28	7

Input Type
PI Pulse Inputs

Enter Number of Temperature Inputs

# Inputs	# Cards ²
4	1
8	2
12	3
16	4
20	5
24	6
28	7

Input Type
TI Temperature Inputs

Enter Number of Analog Outputs

# Outputs	# Cards ²
5	1
10	2
15	3
20	4
25	5
30	6
35	7

Output Type
AO Analog Outputs

Enter Number of Relays

# Relays	# Cards ²
5	1
10	2
15	3
20	4
25	5
30	6

Relays
RY Relays

Ethernet
E Ethernet

Printer Device
P Printer Card²

Approvals

G	General Purpose: Electrical Safety Certification UL & C-UL (E160849)
H	Hazardous Area Certification Nonincendive Division 2 UL & C-UL (E516990)
N	No Approvals ¹

Example Model Numbers:

PD9000-6G-4AI-4PI-5AO-10RY-E
90-264 VAC, UL Listed for Ordinary Location.
Includes: 4 Analog Inputs, 4 Pulse Inputs, 5 Analog Outputs, 10 Relays, and Ethernet

PD9000-7H-4AI-4PI-5AO-10RY-E
90-264 VAC, UL & C-UL for Hazardous Areas.
Includes: 4 Analog Inputs, 4 Pulse Inputs, 5 Analog Outputs, 10 Relays, and Ethernet

PD9000-6N-4AI-15DI-4TI-5AO-5RY-P
90-264 VAC, No Approvals.
Includes: 4 Analog Inputs, 15 Digital Inputs, 4 Temperature Inputs, 5 Analog Outputs, 5 Relays, and Printer Card

Power Options

6	90-264 VAC
7	24 VDC

(1) "N" No Approvals is a requirement when the ConsoliDator+ includes any temperature input cards, digital input cards, or the printer card. All other builds without these options must be either G or H models.

(2) The ConsoliDator+ may have up to 7 I/O cards. Up to 6 relays cards, or any other 7-card combination. The printer card occupies one I/O slot.

(3) 5 digital inputs are standard on all models. Additional digital inputs available using I/O cards.

Go To www.predig.com/PD9000ModelGen To Create Your ConsoliDator+ Model Number

Add-On Features	
Model	Description
PDK9000-M1	Add-On Feature: ConsoliDator+ Modbus Client/Snooper/Spoofers (Ver. 2.1 & Up)
PDK9000-D1	Add-On Feature: ConsoliDator+ USB Data Logger (Ver. 2.2 & Up)
PDK9000-B1	Add-On Feature: ConsoliDator+ Batch Control (Ver. 2.4 & Up)

Note: Add-On features that are ordered with the ConsoliDator+ will be activated at the factory. Add-On features can be ordered for existing ConsoliDator+ provided the firmware version meets or exceeds those listed above. The user will receive a key they can enter into the ConsoliDator+ to unlock the Add-On feature. See the [PD9000 Manual](#) for instructions on how to enable Add-On features.

⚠ CAUTION

- Do not write configuration files created with older versions of the firmware and software to controllers with Add On features enabled (Ver. 2.1 & up). This can create undesirable results, especially with the function keys F1-F4 and the digital inputs.

⚠ IMPORTANT

- The Auto-Tune PID Control and the Digital Switch functions are standard on versions 2.3 & up.

Input / Output Cards	
Model	Description
PDA9000-C4AI	(4) Isolated 4-20 mA Inputs Card for ConsoliDator+
PDA9000-C4PI	(4) Pulse Inputs Card for ConsoliDator+
PDA9000-C4TI	(4) Temperature Inputs Card for ConsoliDator+*
PDA9000-C15DI	(15) Digital Inputs Card for ConsoliDator+*
PDA9000-C5AO	(5) Isolated 4-20 mA Outputs Card for ConsoliDator+
PDA9000-C5RY	(5) Relays Card for ConsoliDator+
PDA9000-CP	ConsoliDator+ Printer Card*

*ConsoliDator+ models with temperature, digital input, or printer cards are not UL Listed. The printer card occupies one I/O slot.

Setup & Calibration Services	
Part Number	Description
PDN-CALCON+12	ConsoliDator+ Calibration and Certificate for up to 12 inputs and outputs
PDN-CALCON+24	ConsoliDator+ Calibration and Certificate for up to 24 inputs and outputs
PDN-CALCON+36	ConsoliDator+ Calibration and Certificate for up to 36 inputs and outputs
PDN-CALCON+12-DATA	ConsoliDator+ Calibration and Certificate with data for up to 12 inputs and outputs
PDN-CALCON+24-DATA	ConsoliDator+ Calibration and Certificate with data for up to 24 inputs and outputs
PDN-CALCON+36-DATA	ConsoliDator+ Calibration and Certificate with data for up to 36 inputs and outputs
PDN-CSETCON+	Custom Setup for ConsoliDator+
PDN-CSETCON+HOUR	Additional Hour Setup for ConsoliDator+

Enclosures		
Model	Description	Dimensions
PDA1909	NEMA 4X Plastic Enclosure for One ConsoliDator+ ⁽¹⁾	11.8" x 11.8" x 5.9" (300 mm x 300 mm x 150 mm) (W x H x D)
PDA1939	NEMA 4X Plastic Enclosure for One ConsoliDator+	13.8" x 17.7" x 7.9" (350 mm x 450 mm x 200 mm) (W x H x D)
PDA2909	NEMA 4 Steel Enclosure for One ConsoliDator+ ⁽¹⁾	12.0" x 12.0" x 6.0" (305 mm x 305 mm x 152 mm) (W x H x D)
PDA2919	NEMA 4 Steel Enclosure for One ConsoliDator+	12.0" x 14.0" x 8.0" (305 mm x 356 mm x 203 mm) (W x H x D)
PDA2929	NEMA 4 Steel Enclosure for One ConsoliDator+	14.0" x 16.0" x 10.0" (355 mm x 406 mm x 254 mm) (W x H x D)
PDA3939	NEMA 4X Plastic Enclosure with Clear Cover for One ConsoliDator+	13.8" x 17.7" x 7.9" (350 mm x 450 mm x 200 mm) (W x H x D)

1. Due to the limited amount of internal space available for these enclosures they are recommended for PD9000s with only a minimal amount of option cards installed.

Accessories



PDA-BUTTON Momentary Pushbutton	
Model	Description
PDA-BUTTON1B	NEMA 4X Black Button
PDA-BUTTON1G	NEMA 4X Green Button
PDA-BUTTON1R	NEMA 4X Red Button

Light / Horn Accessories	
Model	Description
MOD-LHRB1	Red Light / Horn and Button with Holes Drilled in Enclosure ⁽¹⁾
MOD-LHGB1	Green Light / Horn and Button with Holes Drilled in Enclosure ⁽¹⁾
MOD-LHYB1	Yellow Light / Horn and Button with Holes Drilled in Enclosure ⁽¹⁾
MOD-LHBB1	Blue Light / Horn and Button with Holes Drilled in Enclosure ⁽¹⁾
MOD-LHWB1	White Light / Horn and Button with Holes Drilled in Enclosure ⁽¹⁾
MOD-LH5CB1	Light / Horn with User Choice of Red, Green, Yellow, Blue or White Light, Button, and Holes Drilled in Enclosure ⁽¹⁾
MOD-LH3LCB1-RYG	Light / Horn with Red, Yellow, Green Light Layers, Button, and Holes Drilled in Enclosure ⁽¹⁾
PDA-LHR	Red Light / Horn
PDA-LHG	Green Light / Horn
PDA-LHY	Yellow Light / Horn
PDA-LHB	Blue Light / Horn
PDA-LHW	White Light / Horn
PDA-LH5C	Light / Horn with User Choice of Red, Green, Yellow, Blue or White Light
PDA-LH3LC-RYG	Light / Horn with Red, Yellow, Green Light Layers



PDA9000SH Stainless Steel Sun Hood	
Model	Description
PDA9000SH	ConsoliDator+ Stainless Steel Sun Hood

UL Requirements: For use on a flat surface of a UL Type 4X Enclosure. The 4X sun hood must remain in place in order to maintain the 4X Rating. Installed to 7 lb-in (0.8 Nm).



PDA2360 Control Stations	
Model	Description
PDA2360-E	Emergency Stop Button
PDA2361-A	1 Black Ack Button
PDA2361-Q	1 Black Silence Button

Note:

1. This MOD supplies the Light / Horn and Button. The enclosure comes pre-drilled with holes for Light / Horn and Button and the user performs the installation and wiring. ConsoliDator+ and enclosure are sold separately. The Light / Horn hole is located on the top left corner of the enclosure and the Button is located on the bottom left side of the enclosure.



PD9501 Multi-Function Calibrator	
Model	Description
PD9501	Multi-Function Calibrator



Signal Splitter & Conditioner Accessories	
Model	Description
PD659-1MA-1MA	Signal Isolator with One 4-20 mA Input and One 4-20 mA Output
PD659-1MA-2MA	Signal Splitter with One 4-20 mA Input and Two 4-20 mA Outputs
PD659-1V-1MA	Signal Conditioner with One 0-10 VDC Input and One 4-20 mA Output
PD659-1MA-1V	Signal Conditioner with One 4-20 mA Input and One 0-10 VDC Output



PDA1024-01 Power Supply	
Model	Description
PDA1024-01	24 VDC Power Supply for DIN Rail



Split Core AC Current Transducer	
Model	Description
PDA6420	Split Core AC Current Transducer. Input: 30/60/120 AAC; Output 4-20 mA

ConsoliDator+ Enclosure Assembly Services



 Enclosed Industrial Control Panel

- Complete Assembly Services with Instruments, Enclosure, Accessories, and Other Components
- Fully Assembled and Wired, Ready for Use
- Includes Backplane and Din Rail Terminal Strips for Connections
- Meticulously Labeled and Professionally Managed Wiring
- Ready for Straightforward On-Site Installation
- Certified as UL/C-UL Enclosed Industrial Control Panels*

*Panels installed with temperature input cards, digital input cards, or printer card are not UL/C-UL panel rated.

Enclosure Assembly Services are available only on the following enclosures: PDA1939, PDA2919, PDA2929, and PDA3939.

For details and ordering information download the PD9000-ENC Data Sheet



Panel Mount Buzzer and Light	
Model	Description
PDA1000	Panel Mount Buzzer and Light



Snubber 0.01µF/470Ω Flexible Leads	
Model	Description
PDX6901	Snubber 0.01µF/470Ω Flexible Leads



Low-Cost Signal Generator	
Model	Description
PD9502	4-20 mA or 0-10 VDC, Low-Cost Signal Generator



Ticket Printer & Accessories	
Model	Description
PD920-DP	Desktop Impact Printer, Plug-in Power Supply, and 10 ft DB9F to DB25M Null Modem Cable
PDA920-DP-WMK	Desktop Printer Wall Mount Kit
PDA9000-CP	ConsoliDator+ Printer Card*

*ConsoliDator+ models equipped with a printer card are not UL Listed, and the printer card occupies one I/O slot.

Your Local Distributor is:

Disclaimer

The information contained in this document is subject to change without notice. Precision Digital Corporation makes no representations or warranties with respect to the contents hereof, and specifically disclaims any implied warranties of merchantability or fitness for a particular purpose.

©2025 Precision Digital Corporation. All rights reserved.

WARNING

Cancer and Reproductive Harm - www.P65Warnings.ca.gov

LDS9000_J 07/25