

# PD6908 Ex-Proof & I.S. Loop-Powered Process Meter

## Instruction Manual



**ProtEX+**

SP Ex IECEx CE

**CAP TOUCH™**

**MeterView XL**

USB Install

- Fully-Approved Explosion-Proof & Intrinsically Safe Loop-Powered Process Meters
- 4-20 mA Input Displayed with  $\pm 0.02\%$  of Full-Scale Accuracy
- 1.5 Volt Drop (4.7 Volt Drop with Backlight)
- 0.7" (17.0 mm) 5 Alphanumeric Characters Top Display
- 0.4" (10.2 mm) 8 Alphanumeric Characters Bottom Display
- 20-Segment Bargraph Standard
- Display Mountable at 0°, 90°, 180°, & 270°
- CapTouch Through-Glass Button Programming with Normal and Delayed Modes
- Loop-Powered Backlight with Red Backlight for Alarm Conditions
- (2) Open Collector Outputs Standard; Assignable to Pulse, Alarm, Timer, or Stopwatch
- (2) Optional Loop-Powered Solid-State Relays; Assignable to Alarm, Control, Timer, or Stopwatch
- Stopwatch & Timer Functions to Drive Relays & Open Collectors
- Optional Isolated 4-20 mA Analog Output
- Relay Pump Alternation Based on Level and Runtime
- Display Relay Runtime & Cycle Count via Relay Info Menu
- Round Horizontal Tank Function; Just Enter Diameter & Length
- 32-Point Linearization, Square Root Extraction and Programmable Exponent Function
- Free PC-Based MeterView XL USB Programming Software
- HART® Protocol Transparent
- Enable and Disable Backlight from Menu
- Operating Temperature Range: -40 to 75°C (-40 to 167°F)
- Installation Temperature Range: -55 to 75°C (-67 to 167°F)
- Conformal Coated PCBs for Dust & Humidity Protection
- Password Protection
- CSA Certified for Explosion-Proof / Dust-Ignition Proof / Flame-Proof
- ATEX and IECEx Certified as Intrinsically Safe
- Flange for Wall or Pipe Mounting; Loop for Stainless Steel Tag; Holes for Tamper-Proof Seal
- Explosion-Proof, IP68, NEMA 4X Die-Cast Aluminum & Stainless Steel Enclosures
- 3-Year Warranty

## PRECISION DIGITAL CORPORATION

233 South Street • Hopkinton MA 01748 USA  
Tel (800) 343-1001 • Fax (508) 655-8990

[www.predig.com](http://www.predig.com)

**PRECISION  
DIGITAL**

# The Complete PD6900 Series

## VantageView+

### Plastic Enclosures - General Purpose



**PD6907-GP-PL**  
Feet & Inches Meter



**PD6908-GP-PL**  
Process Meter



**PD6928-GP-PL**  
Flow Rate/Totalizer



### Aluminum Enclosures - Explosion-Proof & I.S.



**PD6907-HA-AL**  
Feet & Inches Meter



**PD6908-HA-AL**  
Process Meter



**PD6928-HA-AL**  
Flow Rate/Totalizer

### Stainless Steel Enclosures - Explosion-Proof & I.S.



**PD6907-HA-SS**  
Feet & Inches Meter



**PD6908-HA-SS**  
Process Meter



**PD6928-HA-SS**  
Flow Rate/Totalizer

# Table of Contents

- Introduction** .....6
- Key Features** .....7
- Ordering Information** .....11
  - Accessories** .....11
- Specifications**.....13
  - Display** .....13
  - General** .....13
  - Enclosure** .....14
  - Input**.....14
  - Common Open Collector & Relay Specifications**.....15
  - Open Collector Outputs** .....15
  - Solid-State Relays** .....15
  - 4-20 mA Transmitter Output**.....15
  - On-Board Digital Input** .....15
  - MeterView XL Software**.....16
- Compliance Information**.....17
  - Hazardous Area Approvals**.....17
  - Electromagnetic Compatibility**.....17
- EU Declaration of Conformity**.....18
- Safety Information** .....18
- Installation**.....18
  - Unpacking** .....18
- Mounting**.....19
  - Dimensions** .....19
  - Cover Jam Screw**.....19
- Connections** .....20
  - Display & Options Modules** .....20
  - Connectors Labeling**.....21
- Wiring Diagrams** .....23
  - Intrinsically Safe Wiring**.....23
    - I/O Parameter Table.....23
  - Explosion-Proof Wiring**.....23
    - Current Loop (4-20 mA) Connections .....23
    - Digital Input Connections .....24
    - 4-20 mA Output Connections .....24
    - Solid-State Relay Connections.....24
    - Open Collector Output Connections.....24
- Setup and Programming** .....25
  - Overview**.....25
  - CapTouch Buttons** .....25
    - CapTouch Buttons Delay .....25
    - Disabling the CapTouch Buttons.....25
    - CapTouch Button Tips & Troubleshooting .....25
  - MeterView XL Programming Software**.....26
  - CapTouch Buttons and Status Indicators**.....27
  - Display Functions & Messages**.....28
  - Main Menu** .....32
    - Setting Numeric Values.....33
  - Scaling the 4-20 mA Input (INPUT)** .....34
    - Available Unit Classes and Units .....35
    - Setting Custom Units (CUSTOM).....36
  - Setting the Display Features (DISPLAY)** .....36
    - Changing the Engineering Units (UNITS) .....36
    - Changing the Decimal Point (DECP) .....36
    - Enabling or Disabling Commas on the Bottom Display (COMMA) .....37
    - Display Capabilities Optimization (TOP and BOTTOM) .....37
    - Configuring the Display (TOP and BOTTOM).....38
    - Programming the Bargraph (BARGRAPH).....39

**Programming the Outputs (OUTPUT) .....39**  
     Open Collector Outputs (OPEN COLLECTR) .....40  
     Solid-State Relay Outputs (RELAY) .....45  
     Isolated 4-20 mA Output (4-20 mA) .....51  
     Output Manual Control (CONTROL) .....51  
**Advanced Features Menu (ADVANCE).....52**  
     Advanced Process Variable Setup (ADV PV SETUP) .....53  
     Low-Flow Cutoff (CUTOFF).....60  
     Noise Filter (FILTER) .....60  
     Enabling Password Protection (PASSWORD) .....60  
     Programmable Function Keys User Menu (USER) .....61  
     Tare (TARE).....62  
     Changing System Settings (SYSTEM) .....63  
**Meter Operation .....65**  
     **CapTouch Buttons Operation .....65**  
         CapTouch Buttons .....65  
         CapTouch Button Tips & Troubleshooting .....65  
     **Function Keys Operation.....66**  
     **Digital Input Operation.....66**  
     **Maximum/Minimum Readings .....66**  
     **Runtime & Cycle Count (INFO).....66**  
     **Changing Engineering Units .....66**  
**Troubleshooting.....67**  
     Reset Meter to Factory Defaults.....67  
     Determining Software Version .....67  
         Factory Default Settings .....68  
     **Troubleshooting Tips.....69**

## Table of Figures

Figure 1. Enclosure Dimensions – Front View ..... 19  
 Figure 2. Enclosure Dimensions – Side View ..... 19  
 Figure 3. Enclosure Dimensions – Top View ..... 19  
 Figure 4. Connector Labeling for PD6908-HA-##-LNN ..... 21  
 Figure 5. Connector Labeling for PD6908-HA-##-L2N ..... 21  
 Figure 6. Connector Labeling for PD6908-HA-##-L3N ..... 22  
 Figure 7. Connector Labeling for PD6908-HA-##-L5N ..... 22  
 Figure 8. 4-20 mA Input Connection without Backlight ..... 23  
 Figure 9. 4-20 mA Input Connection with Backlight ..... 23  
 Figure 10. Digital Input Connections ..... 24  
 Figure 11. 4-20 mA Output Connections ..... 24  
 Figure 12. Solid-State Relay Connections ..... 24  
 Figure 13. Open Collector Output Connections ..... 24



Watch the Loop-Powered Meters Video



Click or Scan

**Disclaimer**

The information contained in this document is subject to change without notice. Precision Digital Corporation makes no representations or warranties with respect to the contents hereof; and specifically disclaims any implied warranties of merchantability or fitness for a particular purpose.

**CAUTION**

- Read complete instructions prior to installation and operation of the meter.

**WARNINGS**

- This product is not recommended for life support applications or applications where malfunctioning could result in personal injury or property loss. Anyone using this product for such applications does so at his/her own risk. Precision Digital Corporation shall not be held liable for damages resulting from such improper use.
- Failure to follow installation guidelines could result in death or serious injury. Make sure only qualified personnel perform the installation.
- For Explosion-Proof / Dust-Ignition Proof / Flame-Proof applications, never remove the meter cover in explosive environments when the circuit is live.
- Cover must be fully engaged to meet for Explosion-Proof / Dust-Ignition Proof / Flame-Proof requirements.

**WARNING**

Cancer and Reproductive Harm - [www.P65Warnings.ca.gov](http://www.P65Warnings.ca.gov)

**Limited Warranty**

Precision Digital Corporation warrants this product against defects in material or workmanship for the specified period under "Specifications" from the date of shipment from the factory. Precision Digital's liability under this limited warranty shall not exceed the purchase value, repair, or replacement of the defective unit. See Warranty Information and Terms & Conditions on [www.prediq.com](http://www.prediq.com) for complete details.

**Registered Trademarks**

All trademarks mentioned in this document are the property of their respective owners.

© 2022 Precision Digital Corporation.  
All rights reserved.

## Introduction

The PD6908 ProtEX+ loop-powered explosion-proof & intrinsically safe meters can be installed virtually anywhere to provide convenient and informative display of any 4-20 mA signal. They can operate down to -40°C and be installed in areas that get as cold as -55°C, however the display will cease functioning. One of the most convenient features of these instruments is their dual-line display which is typically used to display the process variable on the 5-character alphanumeric top display and the units of measure or a tag on the 8-character alphanumeric bottom display. Another common setup is to display the input in one scale on the top display (such as feet) and in another scale on the bottom display (such as gallons). The top display uses 12-segment, and the bottom display uses 14-segment alphanumeric characters for clear indication of tags, units, or alarm messages.

Further enhancing the display on these instruments is a 20-segment bargraph.

These loop-powered meters can be installed virtually anywhere because they get their power from the 4-20 mA loop and therefore require no separate power source. And they only drop 1.5 V (4.7 V with backlight), so they add very little burden to the loop. Additional features that allow these instruments to be installed virtually anywhere include a NEMA 4X, IP68 explosion-proof enclosure, an operating temperature range of -40 to 167°F (-40 to 75°C), conformally coated PCBs, and a backlit LCD that can be read in bright sunlight or dimly lit areas.

The ProtEX+ Series is CSA Certified as Explosion-Proof / Dust-Ignition Proof / Flame-Proof and ATEX and IECEx Certified as Intrinsically Safe. The enclosure itself is ATEX, IECEx, CSA, and UL approved.

Free, PC-based, MeterView XL software that connects to the meter via a micro USB cable is available for programming and setup of the meters. For more details, see the [MeterView XL manual](#). Four CapTouch through-glass buttons are available to operate the instrument without removing the cover.

All models come equipped with two open collector outputs and a digital input. There are also models available with two solid-state relays and isolated 4-20 mA analog output options. The open collector outputs are useful for alarm indication. The digital input can be used to acknowledge the relays, to start/stop a timer/stopwatch, and more. The relays can be programmed for alarm indication, on/off control, or pump alternation.

## Key Features

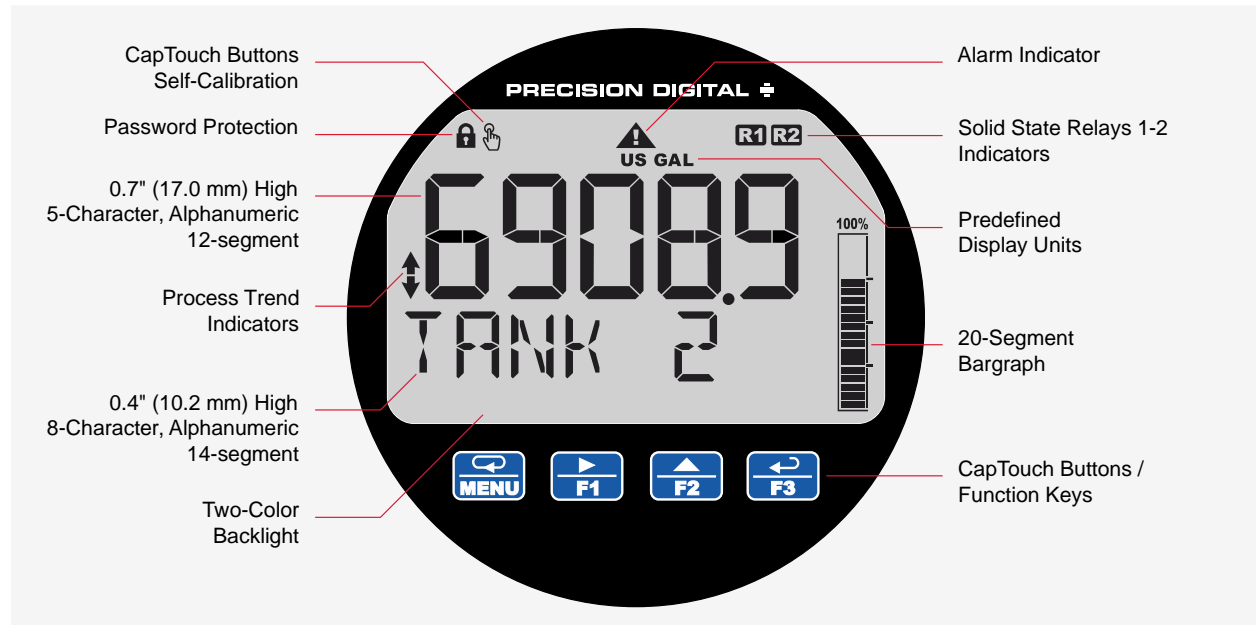

### 2X More Informative Display

The PD6908 display offers a 50% larger display area and is twice more informative than previous generations of loop-powered explosion-proof meters. Featuring an alphanumeric dual-line display and a 20-segment bargraph, reading and understanding process values is easy and intuitive. The addition of status indicators provides a quick glance at alarm conditions, relays, process trends, and more. Predefined display units give users even more display flexibility. Plus, the high contrast backlit LCD display is readable from far away and under various lighting conditions.

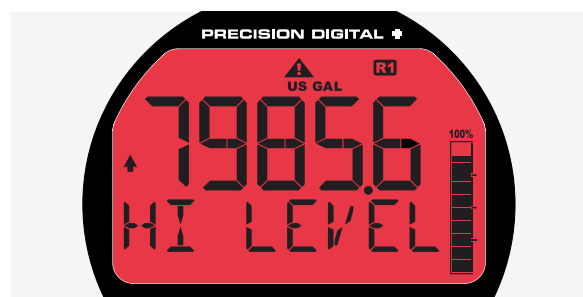

### Backlight Turns Red on Alarm

When an alarm occurs, the display can be programmed to turn red, flash, and display an alarm indicator . In addition, a unique custom alarm message for each of the two relays and two open collectors can be displayed on the bottom display. These features can be activated even if no relay or open collector is connected.

### CapTouch Through-Glass Buttons

The PD6908 is equipped with four capacitive sensors that operate as through-glass buttons so that it can be operated without removing the cover (and exposing the electronics) in a hazardous area. CapTouch buttons are designed to work under any lighting condition and to protect against false triggering. They can be disabled for security via a switch on the display module.



CapTouch buttons have two modes of operation: Normal and Delayed. Delayed mode prevents accidental trigger of the buttons. In the Delayed mode, the buttons enter into a low sensitivity state (sleep) and they ignore quick button presses after 20 seconds of inactivity. To wake up the buttons, press and hold any button for more than 2 seconds, the buttons respond normally.



### Wide Viewing Angle

The window and display module have been optimized to provide a wide viewing angle of approximately ±40°; nearly twice that of the competition. Plus, the display module can be rotated in 90° increments providing added mounting flexibility.

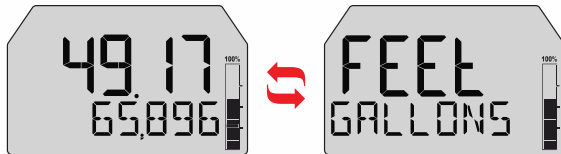

### Dual-Scale Feature

Users can use the dual-scale feature to display the input in two different scales. For instance, the example above shows an application where the display shows the input in feet and gallons while the display toggles between process values and units.

### Predefined and Custom Units

The meter has six available preprogrammed unit classes: volume, height, temperature, pressure, weight, and rate. When the desired unit class or unit of measure within a class is not available, a custom unit may be programmed.

### 14-Segment Characters

Notice how much better letters like “T”, “N” and “K” appear as 14-segment characters on the bottom display vs. 7-segment characters found on other meters.





### Password Protection

A password can be set up for programming security to prevent unauthorized changes to the programmed parameter settings.

### Enable / Disable Backlight

The backlight may be enabled or disabled using the System - Backlight menu. The backlight is enabled by default, but the input must be wired appropriately for the backlight to function. See *Enabling or Disabling the Backlight (BACKLITE)* on page 64 for details.

### Multiple Outputs

- Two open collector outputs (standard)
- Two solid-state relays   (optional)
- One 4-20 mA output (optional)

The open collector outputs and relays generally operate in the same manner, with the major exception being the open collectors are not available for pump alternation and the relays are not available with pulse features. The open collectors and relays can be controlled either automatically or manually.

The isolated analog output signal can be configured to represent the process variable (PV1, PV2, or retransmit). It can also be reverse scaled such that the meter’s high calibration value outputs 4 mA and the meter’s low calibration outputs 20 mA.



### Free MeterView XL Programming Software

The fastest and easiest way to program the meter is using the free MeterView XL programming software. This software greatly simplifies the programming process and allows the user to save configuration files for later use.

The meter connects to the PC via a provided micro-USB cable and is powered by the USB connection, so no additional power is needed during programming.



### Easy Wiring & Service

The PD6908 has been designed for easy wiring and servicing. All connections are made to removable screw terminal blocks. There are no exposed printed circuit boards.



### Modern and Practical Enclosure

The PD6908 NEMA 4X, IP68 enclosure provides serious protection from the elements, high impact, corrosion, and electrical interference. Plus, the extensive worldwide agency approvals allow it to be installed virtually anywhere.



#### Aluminum or Stainless Steel Enclosure

The enclosure is available in copper-free (0.3%), die-cast aluminum and type 316 stainless steel.



#### Built-In Flange for Pipe Mounting

The built-in mounting flange allows easy mounting to walls or pipes.



A slot on the back makes it easy to center the unit on a pipe. There are two 3/4" NPT threaded conduit holes for wiring.



#### Grounding Screw

A grounding screw is provided on the top of the enclosure.



#### SS Tag Attaching Loop

The enclosure is also equipped with a loop at the top to easily attach a PDA-SSTAG stainless steel tag.



#### Tamper-Proof Capability

The instrument can be made tamper-proof by inserting a wire through the built-in loop on the base of the enclosure and a hole in the lid of the enclosure and securing this wire with a lead seal.

### Pump Alternation

The PD6908 can be used as a pump controller to alternate two pumps and indicate high and low alarm conditions. The pumps can be programmed to alternate on level and runtime and the display can be programmed to turn red and flash a message on alarm conditions. The meter can display the pump runtimes and the number of times they have cycled.

See the *Pump Control with Alternation & Alarm Example* on page 49 for full details.

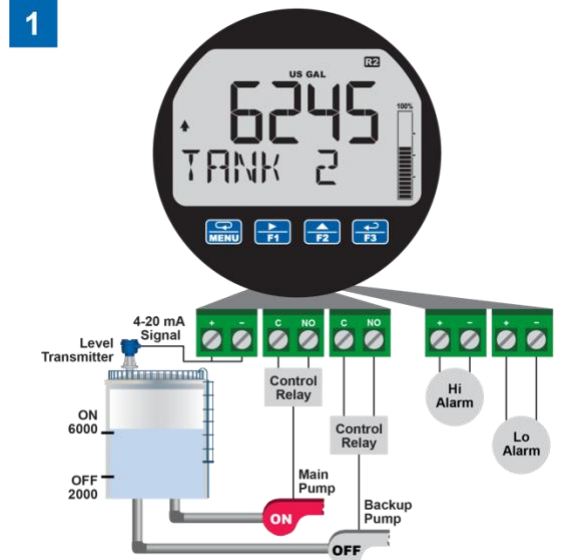

Relay #2 turns the main pump on at 6000 gallons and turns it off at 1000 gallons. **R2** lights up to show relay 2 is energized. The **▲** indicates level is rising.

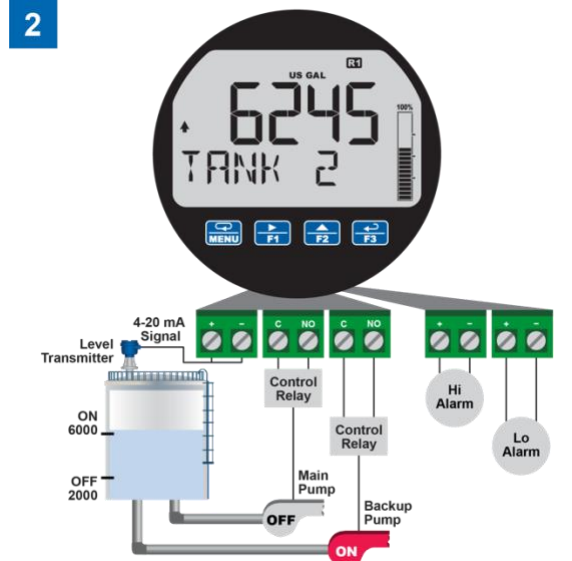

With the Pump Alternation feature activated, the next time the level reaches 6000 gallons, relay #1 transfers and starts the backup pump. **R1** lights up to show relay 1 is on.

### Input Signal Conditioning

To satisfy applications that require scaling in ways other than the usual 2-point linear method, the PD6908 can also be scaled for square root (DP flow), programmable exponent (open channel flow) or round horizontal tank volume calculation.

#### Round Horizontal Tank Linearization

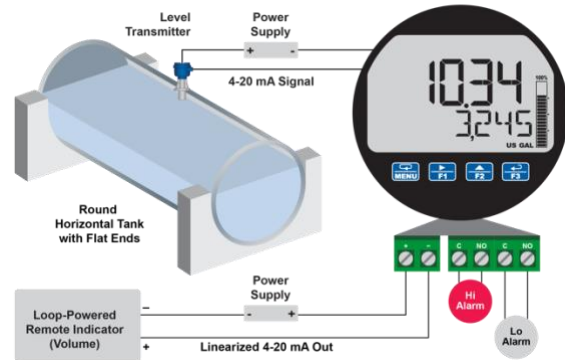

This function automatically calculates the volume in a round horizontal tank with flat ends and allows that reading to be displayed on the bottom display. This results in a meter that displays the height of the tank on the top display and volume on the lower display. The user only needs to enter the diameter and length of the tank and the meter takes care of the rest.

#### Square Root Linearization

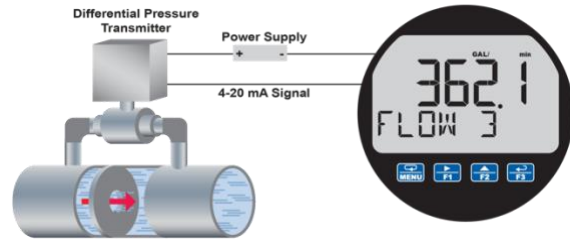

The square root function can be used to linearize the signal from a differential pressure transmitter and display flow rate in engineering units.

#### Programmable Exponent Linearization

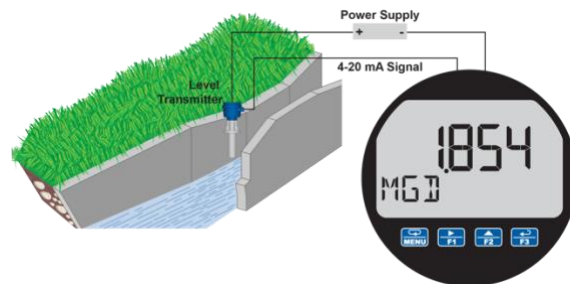

The programmable exponent can be used to linearize the signal from level transmitters in open-channel flow applications using weirs and flumes.

## Ordering Information

### Hazardous Area Instruments

ProtEX+ PD6908 • Decimal Models – Aluminum Enclosure	
Model	Description
PD6908-HA-AL-LNN	Loop-Powered Explosion-Proof & Intrinsically Safe Process Meter, No Options
PD6908-HA-AL-L2N	Loop-Powered Explosion-Proof & Intrinsically Safe Process Meter, Two Solid-State Relays
PD6908-HA-AL-L3N	Loop-Powered Explosion-Proof & Intrinsically Safe Process Meter, 4-20 mA Analog Output
PD6908-HA-AL-L5N	Loop-Powered Explosion-Proof & Intrinsically Safe Process Meter, Two Solid-State Relays & 4-20 mA Analog Output

ProtEX+ PD6908 • Decimal Models – Stainless Steel Enclosure	
Model	Description
PD6908-HA-SS-LNN	Loop-Powered Explosion-Proof & Intrinsically Safe Process Meter, No Options
PD6908-HA-SS-L2N	Loop-Powered Explosion-Proof & Intrinsically Safe Process Meter, Two Solid-State Relays
PD6908-HA-SS-L3N	Loop-Powered Explosion-Proof & Intrinsically Safe Process Meter, 4-20 mA Analog Output
PD6908-HA-SS-L5N	Loop-Powered Explosion-Proof & Intrinsically Safe Process Meter, Two Solid-State Relays & 4-20 mA Analog Output

#### Notes:

- All models come with bargraph, two open collector outputs, and one digital input standard.
- The meter comes standard with two 3/4" NPT conduit holes. To order models with M20 conduit holes instead, add -21 at the end of the part number (e.g. PD6908-HA-AL-LNN-21)

## Accessories

Model	Description
<a href="#">PD659</a>	Signal Isolators, Splitters, and Conditioners
<a href="#">PD9501</a>	Multi-Function Calibrator
<a href="#">PD9502</a>	Low-Cost Signal Generator
<a href="#">PDA1002</a>	6" DIN Rail Mounting Kit
<a href="#">PDA1024-01</a>	24 VDC Transmitter Power Supply for DIN Rail
<a href="#">PDA6846</a>	Steel 2" U-Bolt Kit. All Material: Zinc Plated Steel; (1) U-Bolt for 2" Pipe with (2) Washers, (2) Lock Washers, and (2) Nuts
<a href="#">PDA6846-SS</a>	Stainless Steel 2" U-Bolt Kit. All Material: Stainless Steel; (1) U-Bolt for 2" Pipe with (2) Washers, (2) Lock Washers, and (2) Nuts
<a href="#">PDAPLUG75</a>	3/4" NPT 316 Stainless Steel Conduit Plug with Approvals
<a href="#">PDARED-M75-F50</a>	M-3/4" NPT to F-1/2" NPT Reducer with Approvals
<a href="#">PDARED-M75-FM20</a>	M-3/4" NPT to F-M20 Reducer with Approvals
<a href="#">PDA-SSTAG</a>	Custom Stainless Steel Tag (see website for convenient ordering form)

#### WARNING

- Accessories do not carry hazardous area approvals unless otherwise specified and are thus not suitable for location in hazardous areas. The use of additional protective devices may allow them to be installed in a safe area and connected to a device in a hazardous area. User should consult a professional engineer to determine suitability of these products for their specific application.

**PDA1024-01 24 VDC Power Supply**



The PDA1024-01 is a DIN rail mounted 1.5 A, 24 VDC power supply that can be used to power the 4-20 mA transmitter.

**PDA6846 2" U-Bolt Kits**



The PDA6846 U-Bolt Kits provide a convenient way to mount the meter to 1.5" or 2" pipes. They are available in steel and stainless steel.

**PDA-SSTAG Stainless Steel Tag**



The PDA-SSTAG is a laser etched stainless steel tag that can be customized with three lines of text. Each tag comes with a stainless steel wire and lead seal for easy mounting wherever you need.

**PD9501 Multi-Function Calibrator**



This [PD9501](#) Multi-Function Calibrator has a variety of signal measurement and output functions, including voltage, current, thermocouple, and RTD.

**PD9502 Low-Cost Signal Generator**



The [PD9502](#) is a low-cost, compact, simple to use 4-20 mA or 0-10 VDC signal generator. It can easily be set for 0-20 mA, 4-20 mA, 0-10 V or 2-10 V ranges. Signal adjustment is made with a one-turn knob. A wall plug is provided with the instrument. Optional USB power bank is available.

## Specifications

Except where noted all specifications apply to operation at +25°C.

### Display

<b>Display</b>	Dual-line LCD with backlight. Both lines: alphanumeric Top: 0.7" (17.8 mm) 5 digits, 12-segment Bottom: 0.4" (10.2 mm) 8 characters, 14-segment Display may be programmed to turn red and flash a user-defined message on alarm condition.
<b>On-Screen Indicators</b>	See <i>CapTouch Buttons and Status Indicators</i> on page 27 for details.
<b>Top Display</b>	5 digits (-9999 to 99999) or 5 characters
<b>Bottom Display</b>	8 digits (-9,999,999 to 99,999,999; separated by commas) or 8 characters (all capital & most lower-case letters)
<b>Backlight</b>	Powered by 4-20 mA loop Intensity varies with signal level
<b>Bargraph</b>	20 segments
<b>Decimal Point</b>	Up to four decimal places on top display and up to seven decimal places on bottom display
<b>Commas</b>	Commas to indicate 1000s (e.g. 88,987,628) on the bottom display only
<b>Dual-Scale Feature</b>	The input can be displayed in different scales on the top and bottom displays. For instance, the top display could display the input in height units and the bottom display could show that same input in volume units.
<b>Alarm Indication</b>	Programmable: loop-powered red backlight, flashing display, alarm symbol ▲, bargraph segment flashes on alarm.
<b>Custom Alarm Messages</b>	Programmable for each relay/open collector: 8 characters maximum; displayed every 10 sec for 1 sec on bottom display. May be turned off.
<b>Display Update Rate</b>	Ambient > -10°C: 1 Update/Second Ambient = -20°C: 1 Update/2 Seconds From -20°C to -40°C the update rate slows down 1 second for every -2°C (e.g. at -24°C, 1 update/4 seconds).
<b>Overrange</b>	Top: 99999; Bottom: 99,999,999 (flashing)
<b>Underrange</b>	Top: -9999; Bottom: -9,999,999 (flashing)

## General

<b>Programming Method</b>	Four CapTouch through-glass buttons when cover is installed. The CapTouch buttons can be used with the cover removed. Free PC-based USB MeterView XL programming software.
<b>Environmental</b>	Operating temperature range: -40 to 75°C (-40 to 167°F) Storage temperature range: -55 to 85°C (-67 to 185°F) Installation temperature range: -55 to 75°C (-67 to 167°F) (The display ceases to function, however inputs and outputs continue to operate) Relative humidity: 0 to 90% non-condensing Printed circuit boards are conformally coated
<b>Noise Filter</b>	Averages the input signal over a period of time between 1 and 16 seconds to dampen the effects of a noisy signal that causes a jumpy display.
<b>Filter Bypass</b>	0.0 to 99.9% of full scale. Input signal changes that are greater than the bypass value are displayed immediately.
<b>Recalibration</b>	Recalibration is recommended at least every 12 months.
<b>Max / Min Display</b>	Max / min readings reached by the process are stored until reset by the user or until power to the meter is turned off.
<b>Tare</b>	Tare function zeros out the meter to remove the weight of a container. Tare function can be assigned to a function key or the digital input.
<b>Password</b>	Programmable password restricts modification of programmed settings.
<b>Non-Volatile Memory</b>	All programmed settings are stored in non-volatile memory for a minimum of ten years if power is lost.
<b>Normal Mode Rejection</b>	64 dB at 50/60 Hz
<b>Connections</b>	Removable screw terminal blocks Display terminals: accept 16 to 30 AWG wire Relay terminals: accept 12 to 26 AWG wire 4-20 mA output: accept 16 to 30 AWG wire
<b>Tightening Torque</b>	Display terminals: 2.5 lb-in (0.28 Nm) Relay terminals: 4.5 lb-in (0.5 Nm) 4-20 mA output terminals: 2.5 lb-in (0.28 Nm)
<b>Overall Dimensions</b>	5.25" x 5.65" x 4.80" (133 x 144 x 122 mm) (W x H x D)
<b>Weight</b>	Aluminum: 5.1 lbs (2.3 kg) Stainless Steel: 9.4 lbs (4.3 kg)
<b>Warranty</b>	3 years parts and labor. See Warranty Information and Terms & Conditions on <a href="http://www.prediq.com">www.prediq.com</a> for complete details.

## Enclosure

<b>Material</b>	AL Models: ASTM A413 LM6 die-cast aluminum, copper-free, enamel coated. -SS Models: ASTM A743 CF8M investment-cast 316 stainless steel
<b>Gasket</b>	Fluoroelastomer
<b>Rating</b>	NEMA 4X, IP68 Explosion-proof
<b>Color</b>	-AL: Blue; -SS: Silver
<b>Window</b>	Borosilicate glass
<b>Conduits</b>	Two ¾" NPT threaded conduit openings. M20 conduits are available. See <i>Ordering Information</i> on page 11 for details.
<b>Flange</b>	Built-in flange for wall and pipe mounting.
<b>Tamper-Proof Seal</b>	Enclosure lid may be secured with tamper-proof seal.
<b>ATEX &amp; IECEx (Enclosure only)</b>	Flameproof protection Ⓢ II 2GD Ex db IIC Gb Ex tb IIIC Db IP66/IP68 Tamb: -55°C to +85°C Certificate No.: Sira 19ATEX1252U Certificate No.: IECEx SIR 19.0075U
<b>CSA (Enclosure only)</b>	Class I, Division 1, Groups A, B, C, D Class II, Division 1, Group E, F, G; Class III Ex db IIC Gb Ex tb IIIC Db Class I, Zone 1, AEx db IIC Gb; Zone 21, AEx tb IIIC Db IP66/IP68/TYP E 4X Tamb: -55°C to +85°C Certificate No.: 80011200
<b>UL (Enclosure only)</b>	Class I, Division 1, Groups A, B, C and D Class II, Division 1, Groups E, F and G Class III; Class I, Zone 1, AEx db IIC Gb Zone 21, AEx tb IIIC Ex db IIC Gb Ex tb IIIC Db IP66/IP68/TYP E 4X Tamb: -55°C to +85°C Certificate Number: E518920

## Input

<b>Input</b>	4-20 mA
<b>Accuracy</b>	±0.02% of span ±1 count, Square root and programmable exponent: 10-100% FS
<b>Voltage Drop</b>	Without backlight: 1.5 V maximum, With backlight: 4.7 V maximum
<b>Equivalent Resistance</b>	Without backlight: 75 Ω @ 20 mA With backlight: 235 Ω @ 20 mA
<b>Input Overload</b>	Over current protection to 1 A maximum, Over voltage protection to 30 VDC max (Between mA+ and mA- / BL-)
<b>Temperature Drift</b>	25 PPM/°C from -40 to 75°C ambient
<b>Function</b>	PV1: Linear (2-32 points), square root, or programmable exponent PV2: Linear (2-32 points) or round horizontal tank
<b>Low-Flow Cutoff</b>	0.1 to 999,999 or disable. Point below at which the display always shows zero.
<b>HART Transparency</b>	The meter does not interfere with existing HART communications; it displays the 4-20 mA primary variable and it allows the HART communications to pass through without interruption. The meter is not affected if a HART communicator is connected to the loop. The meter does not display secondary HART variables.

## Common Open Collector & Relay Specifications

<b>Number</b>	Two open collectors & two relays
<b>High or Low Alarm</b>	User programmable for high or low alarm
<b>Alarm Deadband</b>	0-100% FS, user programmable
<b>Output Assignment</b>	Alarm, Timer, Stopwatch, or Disable
<b>Alarm Output Source</b>	Assign to PV (PV1, PV2) or Digital Input
<b>On &amp; Off Time Delay</b>	0 to 9,999 seconds
<b>Fail-Safe Operation</b>	Independent for each open collector and relay. Fail-safe on, the output is on under normal conditions. Fail-safe off, the output is on under alarm conditions.
<b>Alarm Operation</b>	Automatic, automatic with manual override, latching (manual reset anytime), latching with reset after cleared (manual reset only after alarm has cleared)
<b>Alarm Indication</b>	Programmable: loop-powered red backlight, flashing display, alarm symbol ▲, bargraph segment flashes on alarm.
<b>Custom Alarm Messages</b>	Programmable for each relay/open collector: 8 characters maximum; displayed every 10 sec for 1 sec on bottom display. May be turned off.
<b>Alarm Acknowledge</b>	CapTouch ACK button or external digital input resets output and screen indication.
<b>Auto Initialization</b>	When power is applied to the meter, open collectors and relays will reflect the state of the input to the meter.
<b>Timer Output</b>	One-shot or Continuous Off Time Delay: 1 sec to 99:59:59 (hrs:min:sec) On Time: 1 sec to 99:59:59 (hrs:min:sec)
<b>Stopwatch</b>	Output turns on when started and off when stopped.

## Open Collector Outputs

<b>Rating</b>	Isolated open collector, sinking NPN 5-30 VDC @ 150 mA maximum
<b>Output Assignment</b>	Pulse, Alarm, Timer, Stopwatch, or Disable
<b>Pulse Output Source</b>	PV (PV1, PV2) or Test Frequency
<b>Pulse Output Factor</b>	0.000001 to 999,999.9
<b>Pulse Width</b>	0.5 ms @ 1 kHz; 500 ms @ 1 Hz; 50% duty cycle
<b>Pulse Output Frequency</b>	1,000 Hz maximum
<b>Quadrature</b>	Available for Output 2
<b>Pulse Output</b>	(90° behind Output 1) 500 Hz max
<b>Alarm Output Source</b>	Assign to PV (PV1, PV2) or Digital Input

## Solid-State Relays

<b>Rating</b>	250 VAC/VDC @ 0.5 A resistive 38 VA; 250 VAC; 0.3 A pilot duty (inductive) 13 VA; 250 VDC; 0.3 A pilot duty (inductive)
<b>Noise Suppression</b>	Metal oxide varistors across outputs
<b>Relay Assignment</b>	Pump Alternation, Alarm, Timer, Stopwatch on/off, or Disable
<b>Alarm Output Source</b>	Assign to PV (PV1, PV2) or Digital Input
<b>Pump Alternation</b>	Relays may be programmed to alternate with each pump cycle with an elapsed time override where the pumps will alternate regardless of level. Pump alternation time can be programmed for 0 to 999:59 (hrs:min)
<b>Relay (Pump) Runtime</b>	Meter will keep track of how long each relay (pump) has operated and display this information.
<b>Relay (Pump) Cycles</b>	Meter will keep track of how many times the relays (pumps) have cycled and display this information.

## 4-20 mA Transmitter Output

<b>Accuracy</b>	±0.05% FS ±0.001mA
<b>Output Source</b>	PV1, PV2, re-transmit; reverse scaling allowed
<b>Scaling Range</b>	1.00 to 23.0 mA
<b>Disable</b>	High impedance state, less than 1 mA
<b>Calibration</b>	Factory calibrated 4.00 to 20.00 mA
<b>Underrange</b>	1.0 mA, 3.5 mA, or 3.8 mA (If input < 3.5 mA); or disable underrange; user selectable
<b>Overrange</b>	20.5 mA, 20.8 mA, or 23.0 mA (If input > 20.5 mA); or disable overrange; user selectable
<b>Isolation</b>	500 V input-to-output
<b>Temperature Drift</b>	0.5 µA/°C max from -40 to 75°C ambient
<b>External Loop Power Supply</b>	7.0 VDC to 30.0 VDC maximum
<b>Output Loop Resistance</b>	10-750 Ω @ 24 VDC; 10-1100 Ω @ 30 VDC

## On-Board Digital Input

<b>Function</b>	Remote acknowledge/reset relays, reset max/min values, etc. See User section of <i>Display Functions &amp; Messages</i> on page 28 for a complete list of capabilities.
<b>Contacts</b>	2.1 VDC on contact. Connect normally open contacts across DI+ and DI-
<b>Logic Levels</b>	Logic High: 2.4 to 30 VDC (max) Logic Low: 0 to 0.9 VDC

## MeterView XL Software

<b>Availability</b>	Free download from <a href="http://www.predig.com">www.predig.com</a>
<b>System Requirements</b>	Microsoft® Windows® 7 & 10
<b>Communications</b>	USB 2.0 (Standard USB A to Micro USB B) Cable provided
<b>Configuration</b>	Configure all parameters on the meter. Configure meters one at a time.
<b>Configuration Files</b>	Generate with or without meter connected; Save to file for later use.
<b>USB Power Connection</b>	Meter is powered by USB connection during programming, if 4-20 mA loop is not connected.

**⚠ WARNING**

- The meter should only be connected to a computer while it is located in a safe area.



To download the latest MeterView XL programming software and manual, visit [predig.com/meterviewxl](http://predig.com/meterviewxl).



## Compliance Information

### Hazardous Area Approvals

<b>CSA</b>	Explosion-proof for use in: Class I, Division 1, Groups B, C and D Dust-ignition proof for use in: Class II/III, Division 1, Groups E, F and G; T6 Flame-proof for use in: Zone 1, Ex d IIC T6 Ta = -55 to 75°C. Enclosure: Type 4X & IP66/IP68. Certificate number: 2325749
<b>ATEX</b> 	II 1 G D Ex ia IIC T4 Ga Ex ia IIC T200°C Da Ta = -40 to 75°C Enclosure: Type 4X & IP66/IP68 Install per Control Drawing DW2636 (contained within <a href="#">LIM6908-2</a> ) Certificate number: CML 18ATEX2089X
<b>IECEX</b>	II 1 G D Ex ia IIC T4 Ga Ex ia IIC T200°C Da Ta = -40 to 75°C Enclosure: Type 4X & IP66/IP68 Install per Control Drawing DW2636 (contained within <a href="#">LIM6908-2</a> ) Certificate number: IECEX CML 18.0050X

### ATEX/IECEX Special Conditions for Safe Use

The following conditions relate to safe installation and/or use of the equipment.

- The equipment loop/power port shall be connected to an intrinsically safe barrier with  $U_o \geq 5.8V$
- The 4-20 mA input port shall be connected to an intrinsically safe barrier with  $U_o \geq 5.1V$
- The PD6928-HA-AL enclosure is manufactured from aluminum. In rare cases, ignition sources due to impact and friction sparks could occur. This shall be considered during installation, particularly if the equipment is installed in a Zone 0 location.
- All cable entries into the equipment shall be via cable glands or conduit which provide a minimum degree of protection of IP54.
- The equipment may not have 500V isolation between the circuit and earth. This shall be taken into account when installing the equipment.

### Year of Construction

This information is contained within the serial number with the first four digits representing the year and month in the YYMM format.

### For European Community:

The PD69XX Series must be installed in accordance with the ATEX directive 2014/34/EU, the product certificates CML 18ATEX2089X, IECEX CML 18.0050X and the product manual.

### Electromagnetic Compatibility

<b>EMC Emissions</b>	<ul style="list-style-type: none"> <li>• CFR 47 FCC Part 15 Subpart B Class A emissions requirements (USA)</li> <li>• ICES-003 Information Technology emissions requirements (Canada)</li> <li>• AS/NZS CISPR 11 Group 1 Class A ISM emissions requirements (Australia/New Zealand)</li> <li>• EN 55011 Group 1 Class A ISM emissions requirements (EU)</li> <li>• EN 61000-6-4 Emissions requirements for Heavy Industrial Environments - Generic</li> </ul>
<b>EMC Emissions and Immunity</b>	EN 61326-1 EMC requirements for Electrical equipment for measurement, control, and laboratory use – industrial use

## EU Declaration of Conformity

For shipments to the EU and UK, a Declaration of Conformity was printed and included with the product. For reference, a Declaration of Conformity is also available on our website [www.prediq.com/docs](http://www.prediq.com/docs).

## Safety Information

### CAUTION

- Read complete instructions prior to installation and operation of the meter.

### WARNINGS

- Hazardous voltages exist within enclosure. Installation and service should be performed only by trained service personnel.
- Service requiring replacement of internal components must be performed at the factory.
- Control room equipment must not use or generate more than 250 VRMS or VDC.
- Hazardous location installation instructions for associated apparatus (barrier) must be followed when installing this equipment.
- For safe installation of an ATEX approved transmitter in series with PD6908 loop-powered process meters, the hazardous location installation instructions for the transmitter, PD6908 loop-powered process meter, and associated apparatus (barrier) must be compatible.
- PD6908 loop-powered process meters do not add capacitance or inductance to the loop under normal or fault conditions.
- Substitution of components may impair hazardous location safety.
- Equipment contains non-metallic materials and therefore special care and consideration should be made to the performance of these materials with respect to chemicals which may be present in a hazardous environment.

## Installation

To access the connectors, remove the enclosure cover and unclip the display module by pulling it from the enclosure. The display module may be disconnected from the options module to facilitate wiring to the options module.

Refer to Control Drawing DW2636 (contained within [LIM6908-2](#)) for details related to intrinsically safe field wiring.

### WARNING

Explosion-Proof / Dust-Ignition Proof / Flame-Proof

- Disconnect from supply before opening enclosure. Keep cover tight while circuits are live. Conduit seals must be installed within 18" (450mm) of the enclosure.

## Unpacking

Remove the meter from box. Inspect the packaging and contents for damage. Report damages, if any, to the carrier.

If any part is missing or the meter malfunctions, please contact your supplier or the factory for assistance.

## Mounting

The PD6908 has a slotted mounting flange that may be used for pipe mounting or wall mounting. Alternatively, the unit may be supported by the conduit using the conduit holes provided. Refer to *Figure 1* and *Figure 2*.

- ⚠ WARNING**
- Do not attempt to loosen or remove flange bolts while the meter is in service.

## Dimensions

All units: inches [mm]

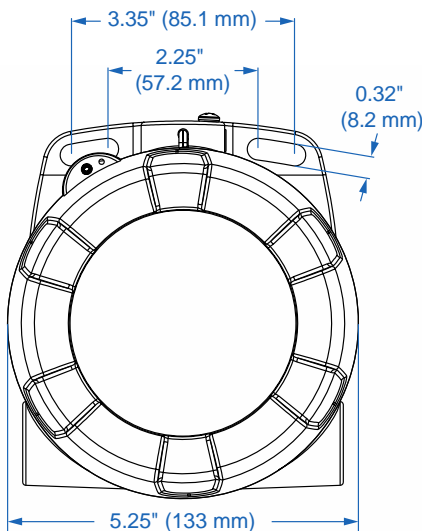

Figure 1. Enclosure Dimensions – Front View

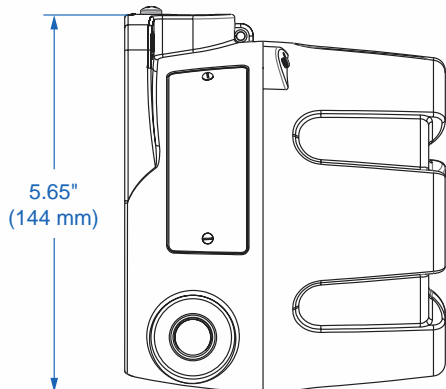

Figure 2. Enclosure Dimensions – Side View

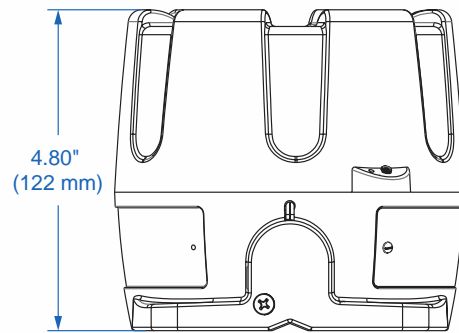

Figure 3. Enclosure Dimensions – Top View



## Cover Jam Screw

The cover jam screw should be properly installed once the meter has been wired and tested in a safe environment. The cover jam screw is intended to prevent the removal of the meter cover in a flame-proof environment without the use of tools. Using a M2 hex wrench, turn the screw clockwise until the screw contacts the enclosure's base. Turn the screw an additional 1/4 to 1/2 turn to secure the cover.



- ⚠ CAUTION**
- Excess torque may damage the threads, screw head, and/or wrench.

## Connections

To access the connectors, remove the enclosure cover and unclip the display module by pulling it from the enclosure. Signal, backlight, open collector, and digital input connections are made to removable connectors on the display module. Relays and 4-20 mA output connections (if installed) are made to removable connectors on the options module mounted in the base of the enclosure. The display module may be disconnected from the options module to facilitate wiring to the options module. Grounding connections are made to the two ground screws provided on the base of the enclosure, one internal and one external.

### **⚠ WARNINGS**

- Observe all safety regulations. Electrical wiring should be performed in accordance with all agency requirements and applicable national, state, and local codes to prevent damage to the meter and ensure personnel safety.
- Static electricity can damage sensitive components.
- Observe safe handling precautions for static-sensitive components.
- Use proper grounding procedures/codes.
- If the meter is installed in a high voltage environment and a fault or installation error occurs, high voltage may be present on any lead or terminal.

## Display & Options Modules

The display module snaps into built-in rails on the enclosure ensuring a secure and perfect fit every time. No tools are needed to install or remove it. The options module is screwed into the base of the enclosure. Both modules completely encase the printed circuit boards.



Options Board (Left) and Display Module (Right)



Options Board Connected to Display Module



Options Board Mounted on the Bottom of Enclosure



Display Module Mounted on Built-In Rails

## Connectors Labeling

The following graphics show the locations of the connectors for each available configuration.

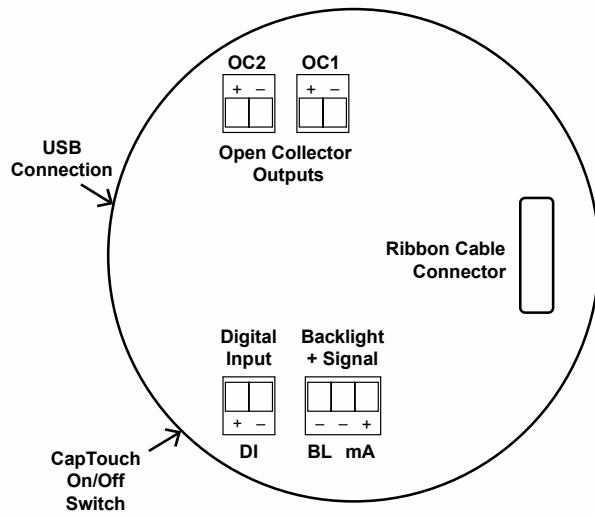

Figure 4. Connector Labeling for PD6908-HA-##-LNN

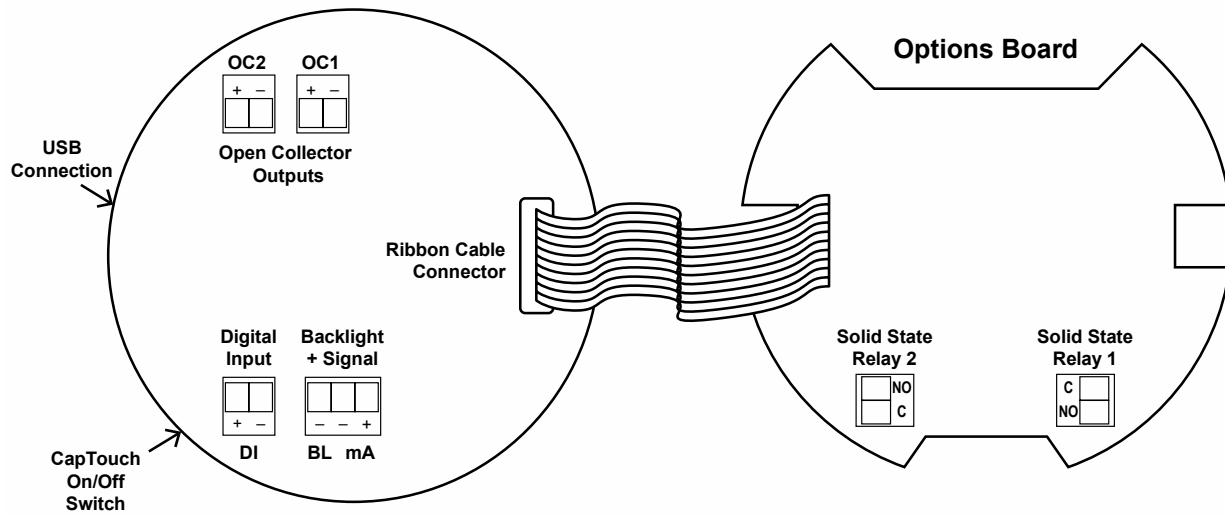

Figure 5. Connector Labeling for PD6908-HA-##-L2N

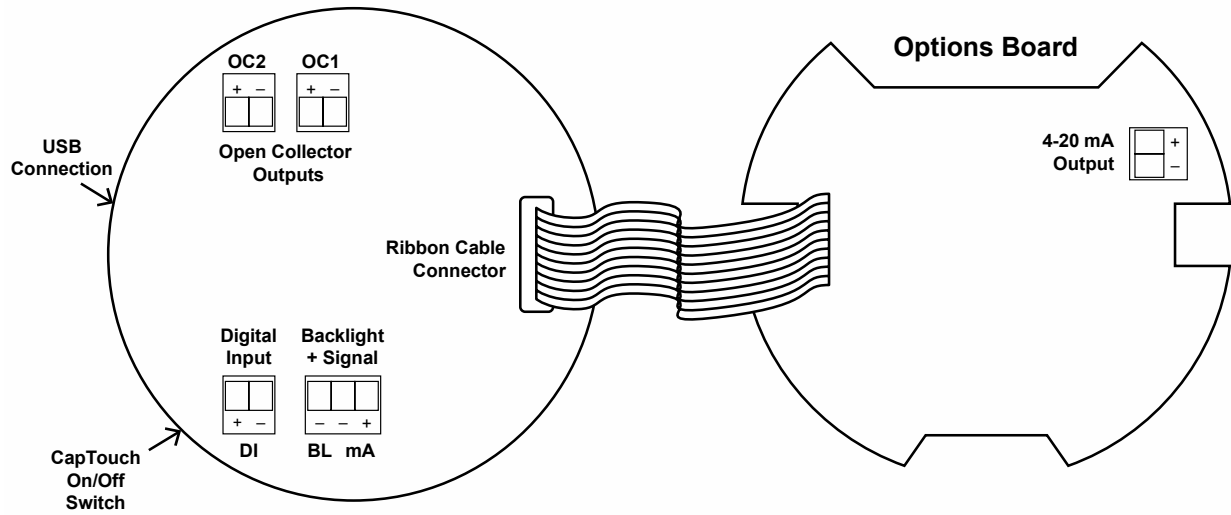

Figure 6. Connector Labeling for PD6908-HA-##-L3N

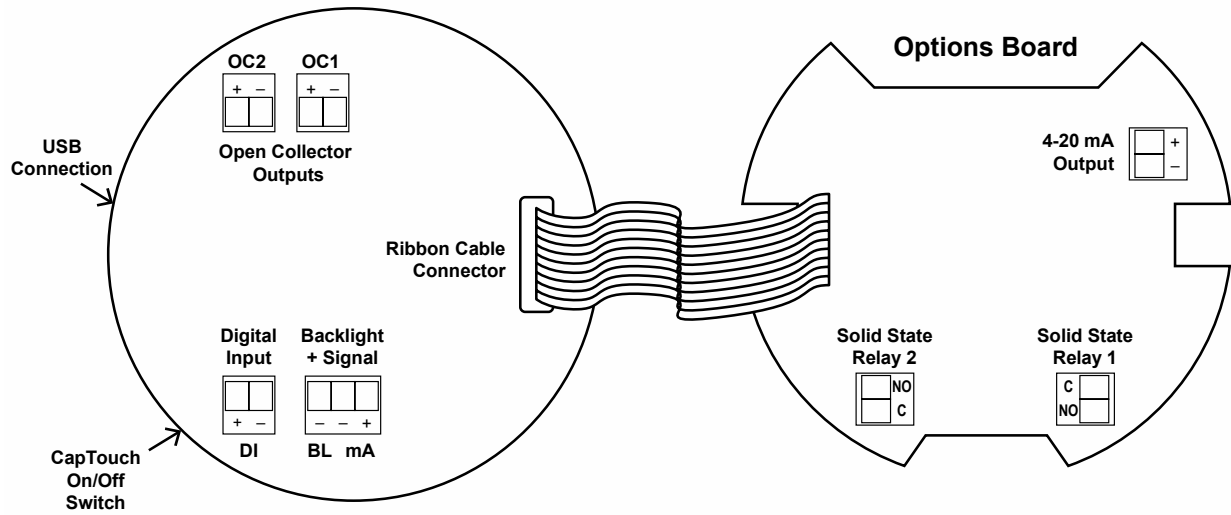

Figure 7. Connector Labeling for PD6908-HA-##-L5N

# Wiring Diagrams

## Intrinsically Safe Wiring

**⚠ WARNING**

- PD6908 installation must be performed in accordance with control drawings included in the [LIM6908-2](#), in order to meet agency approval ratings.
- For ATEX certification, barrier and transmitter must be ATEX Certified with Entity Parameters and must be connected per manufacturer's instructions.
- Service requiring replacement of internal components must be performed at the factory.
- Entire meter assembly (electronic assembly) may be replaced in the field with a unit supplied from the factory labeled "Field Modification".

### I/O Parameter Table

4-20 mA Loop Input			Switch Port		
U <sub>i</sub>	=	30 V	U <sub>i</sub>	=	30 V
l <sub>i</sub>	=	175 mA	l <sub>i</sub>	=	175 mA
P <sub>i</sub>	=	1 W	P <sub>i</sub>	=	1 W
C <sub>i</sub>	=	0	C <sub>i</sub>	=	0
L <sub>I</sub>	=	0	L <sub>I</sub>	=	0
Open Collector Outputs			Backlight Terminal		
U <sub>i</sub>	=	30 V	U <sub>i</sub>	=	30 V
l <sub>i</sub>	=	175 mA	l <sub>i</sub>	=	175 mA
P <sub>i</sub>	=	1 W	P <sub>i</sub>	=	1 W
C <sub>i</sub>	=	0	C <sub>i</sub>	=	0
L <sub>I</sub>	=	0	L <sub>I</sub>	=	0
Power Supply Input			mA Output		
U <sub>i</sub>	=	30 V	U <sub>i</sub>	=	30 V
l <sub>i</sub>	=	175 mA	l <sub>i</sub>	=	175 mA
P <sub>i</sub>	=	1 W	P <sub>i</sub>	=	1 W
C <sub>i</sub>	=	0	C <sub>i</sub>	=	0
L <sub>I</sub>	=	0	L <sub>I</sub>	=	0
Relay Outputs					
U <sub>i</sub>	=	30 V			
l <sub>i</sub>	=	1000 mA			
P <sub>i</sub>	=	1 W			
C <sub>i</sub>	=	0.013 uF			
L <sub>I</sub>	=	0			
U <sub>o</sub>	=	11.55 V			
l <sub>o</sub>	=	1 mA			
P <sub>o</sub>	=	0.012 W			

## Explosion-Proof Wiring

### Current Loop (4-20 mA) Connections

Signal connections are made to a three-terminal connector. See *Connectors Labeling* on page 21. The following figures show a 4-20 mA current loop connected to the meter. *Figure 8* shows the connection without the backlight and *Figure 9* shows the connection with the backlight (the backlight can be disabled/enabled in the SYSTEM menu, if connected). The meter and the backlight are powered by the 4-20 mA current loop.

There are no switches or jumpers to set up for the input. Setup and programming are performed through the CapTouch buttons or PC-based software.

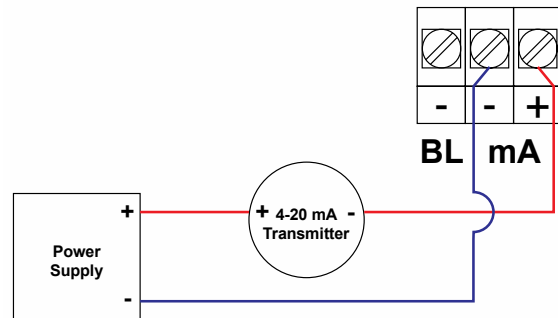

Figure 8. 4-20 mA Input Connection without Backlight

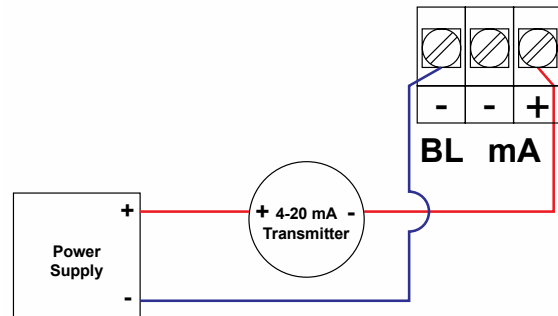

Figure 9. 4-20 mA Input Connection with Backlight

The current input is protected against current overload up to 1 amp. The display may or may not show a fault condition depending on the nature of the overload.

### Digital Input Connections

A digital input is standard on the meter. This digital input is connected with a normally open contact across DI+ and DI-, or with an active low signal applied to DI+ and DI-.

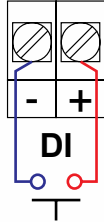

Figure 10. Digital Input Connections

### 4-20 mA Output Connections

Connections for the 4-20 mA transmitter output are made to the connector terminals labeled 4-20 mA Output on Figure 6, on page 22. The 4-20 mA output must be powered from an external power supply.

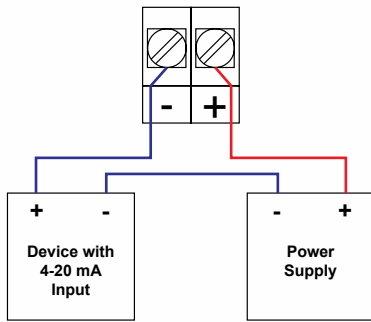

Figure 11. 4-20 mA Output Connections

### Open Collector Output Connections

Open collector output 1 and 2 connections are made to terminals labeled OC1 and OC2 on Figure 4, page 21. Connect the alarm or pulse input device as shown below.

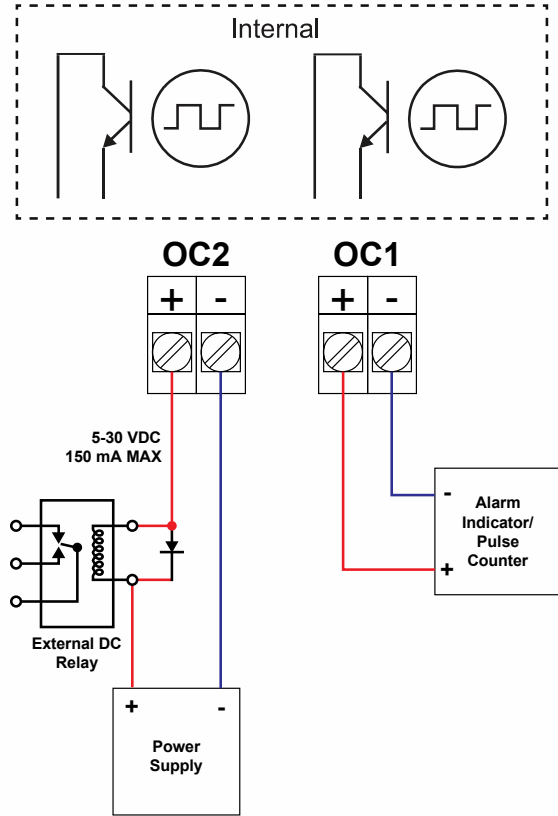

Figure 13. Open Collector Output Connections

### Solid-State Relay Connections

Relay connections are made to two-terminal connectors, as shown on Figure 5, page 21. Each relay's C terminal is common only to the normally open (NO) contact of the corresponding relay.

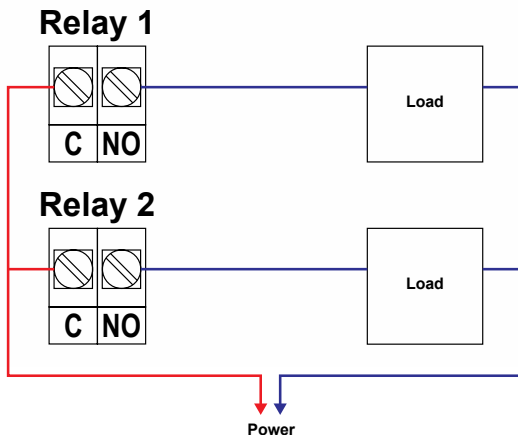

Figure 12. Solid-State Relay Connections



## Setup and Programming

The meter is factory calibrated prior to shipment to display 0.00 to 100.00, which corresponds to the 4-20 mA input. The calibration equipment is traceable to NIST standards.

### Overview

There are no jumpers to set; setup and programming is done through the CapTouch buttons or the free MeterView XL PC-based software.

The meter may be powered via the micro-USB connection located on the display module for the purpose of programming only. The backlight will not work while the meter is powered via the USB connection.

### CapTouch Buttons

The PD6908 is equipped with four capacitive sensors that operate as through-glass buttons so that it can be programmed and operated without removing the cover (and exposing the electronics) in a hazardous area.



These buttons can be disabled for security by selecting the Lock setting on the switch located on the side of the display module, close to the Menu button.

To actuate a button, press one finger to the glass directly over the marked button area. When the cover is removed, the CapTouch buttons can be used after the meter completes a self-calibrating routine (hand symbol flashes). The sensors are disabled when more than one button is pressed, and they will automatically re-enable after a few seconds (hand symbol off).

### CapTouch Buttons Delay

The CapTouch have two modes of operation: *Normal* and *Delayed*. Use the Delayed mode to prevent accidental trigger of the buttons. In the Delayed mode, the buttons enter into a low sensitivity state (sleep) and they ignore quick button presses after 20 seconds of inactivity. To wake up the buttons, press and hold any button for more than 2 seconds, the buttons respond normally.

### Disabling the CapTouch Buttons

The CapTouch buttons can be disabled by moving the slide switch, located on the display module to the Lock position; see the image below.



### CapTouch Button Tips & Troubleshooting

The CapTouch buttons are designed to work under any lighting condition and to protect against false triggering. If the CapTouch buttons are not needed during operation, they can be disabled (slide switch to Lock).

- To remove cover with power applied (safe area only), or to clean the window, place your hand over the buttons; this will temporarily disable the CapTouch buttons to prevent inadvertent use.
- Keep the glass window clean.
- Tighten the cover securely.
- Use a password to prevent tampering.

#### **▲ IMPORTANT**

- CapTouch buttons will not work if two or more buttons are detected as being pressed simultaneously. Be careful to avoid triggering multiple buttons or reaching across one button location to press another.

## MeterView XL Programming Software



The fastest and easiest way to program the meter is using the free MeterView XL programming software. This software greatly simplifies the programming process and allows the user to save configuration files for later use.

The meter connects to the PC via a provided micro-USB cable and is powered by the USB connection, so no additional power is needed during programming.

To download the latest MeterView XL programming software and manual, visit [predig.com/meterviewxl](http://predig.com/meterviewxl).

### ⚠ WARNING

- The meter should only be connected to a computer while it is located in a safe area.

### ⚠ CAUTION

- Care should be exercised to avoid ground loops when connecting the USB to an active loop (e.g. power supply, transmitter, loop-powered meter, etc.). It is recommended to connect the (mA+) terminal of the meter to the (-) terminal of a two-wire transmitter and the (mA-) to the (+) of the next device in the loop or to the (-) terminal of the power supply.



## CapTouch Buttons and Status Indicators



### Buttons

Button	Description
	Menu
	Right Arrow/F1
	Up Arrow/F2
	Enter/F3

1. Press the **Menu** button to enter or exit the Programming Mode at any time.
2. Press or hold the **Right-Arrow** button to scroll forward through the menus, select digits during numeric programming, select characters during text programming, or decrement the value of a digit or character selected with the **Up-Arrow** button.
3. Press and hold the **Right-Arrow** button to zero or clear digits/characters while in data-entry mode.
4. Press or hold the **Up-Arrow** button to scroll backwards through the menus or to increment the value of a digit or character.
5. Press the **Enter** button to access a menu or to accept a setting or programmed digit/character value.

### Indicators

Indicator	State	Description
	Steady	Process trend arrows
	Flashing	Alarm Indicator
	Steady	Password protected
	Steady	Solid-state relay 1
	Steady	Solid-state relay 2
	Flashing	CapTouch buttons self-calibrating (wait)
	Steady	PV Bargraph
	Flashing	Alarm condition: Bargraph segment flashes on alarm

### Units

Display	Units
Top	rev, lb, ton, ft <sup>3</sup> , bbl, m <sup>3</sup> , kg, US GAL, IGAL, GAL, GAL/hr, GAL/sec, GAL/min, GAL/day, ° (degree), % (percent)
Bottom	lb, m <sup>3</sup> , ton, bbl, ft <sup>3</sup> kg, US GAL, IGAL, GAL

### CAUTION

- Avoid touching more than one button at a time, otherwise the buttons become unresponsive and enter into a self-calibrating routine. This is indicated by the flashing hand symbol

## Display Functions & Messages

The meter displays various functions and messages during setup, programming, and operation. The following table shows the main menu functions and messages in the order they appear in the menu.

Display Functions & Messages	
Parameter	Action/Setting Description
INPUT (PV 1 and PV 2)	Program the meter 4-20 mA input (two menus, PV 1 and PV 2, are available if in dual-scale mode; see PV 2 under advanced features menu)
SCALE PV (1 or 2)	Scale the selected PV
UNITS	Select the display units
VOLUME	Volume unit class
GAL	Gallons
L	Liters
IGAL	Imperial Gallons
M3	Cubic Meters
BBL	Barrels
BUSH	Bushels
cuYD	Cubic Yards
cuFE	Cubic Feet
cuIn	Cubic Inches
L.BBL	Liquid barrels
BBBL	Beer barrels
HECLL	Hectoliter
AF	Acre-Foot
CUSTOM	Custom Unit
HEIGHT	Height unit class
INCH	Inches
FEET	Feet
YARD	Yards
CM	Centimeters
M	Meters
CUSTOM	Custom unit
TEMP	Temperature unit class
°F	Degrees Fahrenheit
°C	Degrees Celsius
K	Kelvin
°RA	Degrees Rankine
PRESSURE	Pressure unit class
PSI	Pounds per square inch
InHG	Inches of mercury
InH2O	Inches of water
mmHG	Millimeters of mercury
KG/CM2	Kilograms per square centimeter
KG/M2	Kilograms per square meter
mBAR	Millibar
BAR	Bar

## Display Functions & Messages

Parameter	Action/Setting Description
PA	Pascal
hPA	Hectopascal
kPA	Kilopascal
MPA	Megapascal
CUSTOM	Custom unit
WEIGHT	Weight unit class
g	Grams
kg	Kilograms
t	Tonnes (metric)
oz	Ounces
lb	Pounds
ton	Tons
CUSTOM	Custom unit
RATE	Rate unit class
/SECOND	Units per second
/MINUTE	Units per minute
/HOUR	Units per hour
/DAY	Units per day
GAL/(T)	Gallons per time unit (T)
L/(T)	Liters per time unit (T)
IGAL/(T)	Imperial gallons per time unit (T)
M3/(T)	Cubic meters per time unit (T)
BBL/(T)	Barrels per time unit (T)
BUSH/(T)	Bushels per time unit (T)
cuYD/(T)	Cubic Yards per time unit (T)
cuFE/(T)	Cubic Feet per time unit (T)
cuIn/(T)	Cubic Inches per time unit (T)
L.BBL/(T)	Liquid barrels per time unit (T)
BBBL/(T)	Beer barrels per time unit (T)
HECLL/(T)	Hectoliter per time unit (T)
AF/(T)	Acre-Foot per time unit (T)
CUSTOM/	Custom unit per time unit (T)
CUSTOM	Custom unit class
CUNIT	Custom unit
INPUT 1	Program input 1 value
INP 1	Enter the input 1 value
DISP 1	Program display 1 value
DSP 1	Enter the display 1 value
INPUT 2	Program input 2 value (up to 32 points)
INP 2	Enter the input 2 value
DISP 2	Program display 2 value (up to 32 points)
DSP 2	Enter the display 2 value
SAVE ?	Press Enter to save programmed units, input, and display values. Press Menu to cancel.

Display Functions & Messages	
Parameter	Action/Setting Description
OUTPUT	<b>Press Enter to save programmed units, input, and display values. Press Menu to cancel.</b>
OPEN COLLECTR	Program the meter's open collector outputs
OUTPUT 1	Open collector 1 setup
OUTPUT2	Open collector 2 setup
DISABLE	Disable the open collector
PULSE	Program the open collector for pulse output
ALARM	Program the open collector for alarm output
TIMER	Program the open collector as a timer
STOPWATCH	Program the open collector to turn on while the stopwatch is running
RELAY	Program the meter's relay outputs
OUTPUT 1	Relay 1 setup
OUTPUT2	Relay 2 setup
DISABLE	Disable the relay
ALARM	Program relay for alarm functionality
PUMPCTRL	Program relay for pump control application
TIMER	Program relay as a timer
STOPWATCH	Program relay to turn on while the stopwatch is running
RELAY INFO	View relay runtime and cycle count
4-20 MA	Program the meter's 4-20 mA output
PV	Program a range to transmit based on the display value
RETRANS	Retransmit the mA input signal
DISABLE	Disable the 4-20 mA output
CONTROL	Program manual or automatic operation for the outputs
OC 1	Open collector 1
OC2	Open collector 2
RELAY 1	Relay 1
RELAY2	Relay 2
4-20 mA	4-20 mA output
AUTO	Set selected output to automatic operation
MANUAL	Manually control selected output operation
ADVANCE	Program the meter's advanced features
PV SETUP (PV 1 & PV 2)	Advanced input programming (two menus, PV 1 and PV 2, are available if in dual-scale mode; see PV 2 under advanced features menu)

Display Functions & Messages	
Parameter	Action/Setting Description
SOURCE	Select PV 2 source (dual-scale only; see PV 2 under advanced features menu)
4-20 mA	Source PV 2 from the mA input
PV 1	Source PV 2 from PV 1
FUNCTN	Select linear, square root, or programmable exponent function
LINEAR	Set meter for linear function and select number of linearization points
SQROOT	Set meter for square root extraction
EXPONENT	Set meter for programmable exponent and enter exponent value
RH TANK	Round horizontal tank (dual-scale only; see PV 2 under advanced features menu)
SCALECAL	Scale or calibrate the mA input
SCALE PV	Scale the input
CAL PV	Calibrate the input
CUTOFF	Set low-flow cutoff
DISABLE	Disable low-flow cutoff
ENABLE	Enable low-flow cutoff
FILTER	Set noise filter value
10 SEC	1 second
20 SEC	2 seconds
40 SEC	4 seconds
80 SEC	8 seconds
160 SEC	16 seconds
OFF	Turn filter off
BYPASS	Set filter bypass (0.0 to 99.9% FS)
PASSWORD	Set a password for the meter
PASS MAIN	Program the main meter password
USER	Assign function keys / digital input
F 1	Assign F1 function key
F 2	Assign F2 function key
F 3	Assign F3 function key
DI	Assign digital input
DISP FN	Set the function key or digital input to display a value
DISPLAY	Cycle max, min, and PV(s)
DISP PV	Display the PV
PCT PV	Display the PV's percentage of max (20 mA)
UNITS	Display the PV's units
TAG	Display the PV's tag
DISP MIN	Display the PV's minimum value
DISP MAX	Display the PV's maximum value
MIN MAX	Display the PV's minimum and maximum value

Display Functions & Messages	
Parameter	Action/Setting Description
mA IN	Display the current mA input value
mAOUT	Display the current mA output value
MENU FN	Set the function key or digital input to access a menu
RLY INFO	Go to relay information menu (INFO)
MANCTRL	Go to output control menu (CONTROL)
TIMR DC 1	Open collector 1 timer
TIMR DC 2	Open collector 2 timer
TIMER R 1	Relay 1 timer
TIMER R 2	Relay 2 timer
TIMERFN	Set the function key or digital input to start or stop a timer
STARTALL	Start all timers
STOPALL	Stop all timers
SSTPALL	Start or stop all timers
DC 1	Start/stop open collector 1 timer
DC 2	Start/stop open collector 2 timer
RLY 1	Start/stop relay 1 timer
RLY 2	Start/stop relay 2 timer
START	Start the selected timer output
STOP	Stop the selected timer output
STR--STP	Start or stop the selected timer output
ALARMFN	Set the function key or digital input to acknowledge an alarm or access set points
ACK	Acknowledge all active alarms
SETPOINT	Access all output set points
SETPDC 1	Access open collector 1 set point
SETPDC 2	Access open collector 2 set point
SETPTR 1	Access relay 1 set point
SETPTR 2	Access relay 2 set point
SWATCHFN	Set the function key or digital input to activate stopwatch
START	Start the stopwatch
STOP	Pause/Stop the stopwatch
STR--STP	Start or stop the stopwatch
TAREFN	Set the function key or digital input to tare the display
TARE	Tare the display value
RST TARE	Reset the display value
HOLD FN	Set the function key or digital input to hold an output
HOLDOUT	Hold all outputs
HL UNHL	Hold or un-hold all outputs
DC 1+2	Hold/un-hold open collector outputs

Display Functions & Messages	
Parameter	Action/Setting Description
RLY 1+2	Hold/un-hold relay outputs
mAOUT	Hold/un-hold 4-20 mA output
HOLD	Hold selected output
HL UNHL	Hold or un-hold selected output
DISABLE	Disable function key or digital input
RST FN	Set the function key or digital input to reset a value
RESET	Reset min, max, or max/min PV
R MINMAX	Reset max and min PV value
HINT	Display hint text on key press and execute action on next key press
OFF	Turn the hint function off
ON	Turn the hint function on
SYSTEM	Program system settings
ADJCAL	Calibrate the analog output
DEFAULT	Reset meter to factory defaults
PV 2	Enable the meter to scale a second PV based on the same 4-20 mA input
DISABLE	Disable dual-scale feature (default)
ENABLE	Enable dual-scale feature
BACKLITE	Enable/disable display backlight
ENABLE	Enable the backlight (default)
DISABLE	Disable the backlight
CAPTUCH	Select CapTouch buttons mode
NORMAL	CapTouch normal (default)
DELAYED	CapTouch delayed
INFO	View meter software version and model; change the identifier tag
SFT	The software ID number
VER	The software version
MODEL	The meter model number
IDTAG	The meter identifier tag Press <i>Enter</i> to edit tag
ICAL	Internal calibration used for scaling
DISPLAY	Program the meter's display
UNITS	Change the display units within the selected unit class
DECP	Change the decimal point location
COMMA	Enable or disable the use of a comma on the bottom display
ENABLE	Enable comma (default)
DISABLE	Disable comma
BARGRAPH	Turn off or change the bargraph
PV ( 1 or 2)	Set the bargraph to display the percentage of a user-selected range
PV PCT ( 1 or 2)	Set the bargraph to display the PV percentage of full scale
OFF	Turn off the bargraph

<b>Display Functions &amp; Messages</b>	
<b>Parameter</b>	<b>Action/Setting Description</b>
TOP	Select what to display on the top display
PV ( 1 or 2 )	Display the process variable
PV+UNIT ( 1 or 2 )	Display the process variable and units alternating
PV+TAG ( 1 or 2 )	Display the process variable and tag alternating
TAG+UNIT	Display tag and units alternating
PV+U+TAG ( 1 or 2 )	Display the process variable, unit, and tag alternating
PV 1+PV 2	Display both process variables (dual-scale only; see PV 2 under advanced features menu)
TAG	Display the tag
STOPWATCH	Display the stopwatch
TIMER OC 1	Display open collector 1 timer
TIMER OC 2	Display open collector 2 timer
TIMER R 1	Display relay 1 timer
TIMER R 2	Display relay 2 timer
MIN	Display minimum value
MAX	Display maximum value
MIN MAX	Display alternating min and max
OFF	Turn top display off
UNITS	Display the units
BOTTOM	Select what to display on the bottom display
UNITS	Display the units
PV ( 1 or 2 )	Display the process variable
PV+UNIT ( 1 or 2 )	Display the process variable and unit alternating
PV+TAG ( 1 or 2 )	Display the process variable and tag alternating
TAG+UNIT	Display the tag and unit alternating
PV+U+TAG ( 1 or 2 )	Display the process variable, unit, and tag alternating
PV 1+PV 2	Display both process variables (dual-scale only; see PV 2 under advanced features menu)
TAG	Display the tag
STOPWATCH	Display the stopwatch
TIMER OC 1	Display open collector 1 timer
TIMER OC 2	Display open collector 2 timer
TIMER R 1	Display relay 1 timer
TIMER R 2	Display relay 2 timer
OFF	Turn bottom display off
PV PCT ( 1 or 2 )	Display the process variable percentage of full scale
mA IN	Display the current mA input value
mA OUT	Display the current mA output value

## Main Menu

The main menu consists of all the meter's programmable functions: *Input*, *Output*, *Advanced*, and *Display*.

- Press **Menu** button to enter *Programming Mode* then press the **Right-Arrow** button to move forward through the menu and the **Up-Arrow** button to move back.
- Press **Menu** at any time to go back one level or press & hold to exit and return to *Run Mode*. Changes made to settings prior to pressing **Enter** are not saved.
- Changes to the settings are saved to memory only after pressing **Enter/F3** to confirm the setting or pressing **Enter/F3** at the **SAVE?** screen when available.

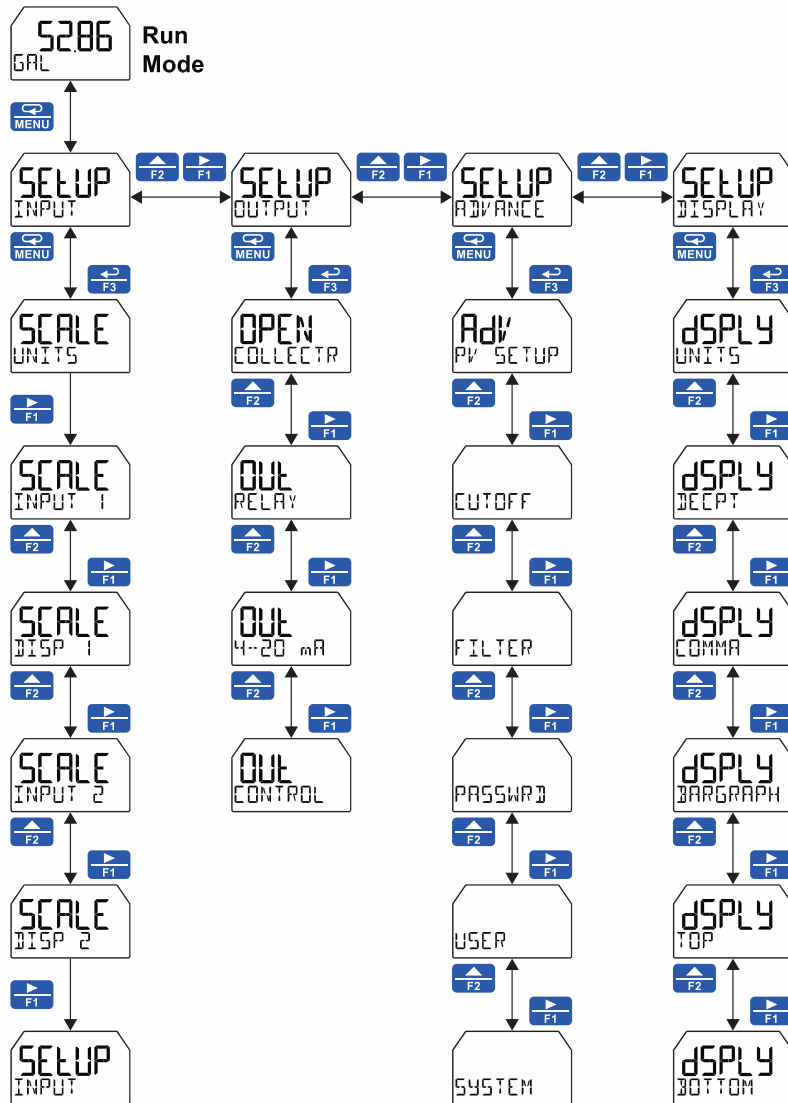

**Note:** The navigation returns to the top



## Setting Numeric Values

The numeric values are set using the **Right** and **Up-Arrow** buttons.

1. Press **Right-Arrow** to select next digit and **Up-Arrow** to increment digit value. The selected digit will flash.
2. Press and hold **Up-Arrow** to auto-increment the display value. If you have made a mistake or would like to enter a new value, select the left-most digit, and press and hold the **Right-Arrow** button until all digits reset to zero.
3. Press the **Enter** button at any time to accept a setting or **Menu** button to exit without saving changes.

**Note:** the underscore in the graphic below is provided to show which digit would be flashing.

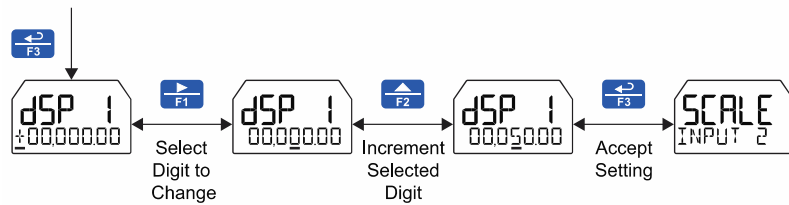

**Note:** Selected digit flashes. Flashing digit demonstrated using underscore.  
Example: 0005000

## Scaling the 4-20 mA Input (INPUT)

It is **very important** to read the following information before proceeding to program the meter:

- The meter is factory calibrated prior to shipment to display 0.00 to 100.00 gal, which corresponds to the 4-20 mA input. The calibration equipment is traceable to NIST standards.
- A calibrated signal source is not needed to scale the meter.

Enter the *Input* menu to scale the meter to display the 4-20 mA input. The input can accept any signal from 4 to 20 mA.

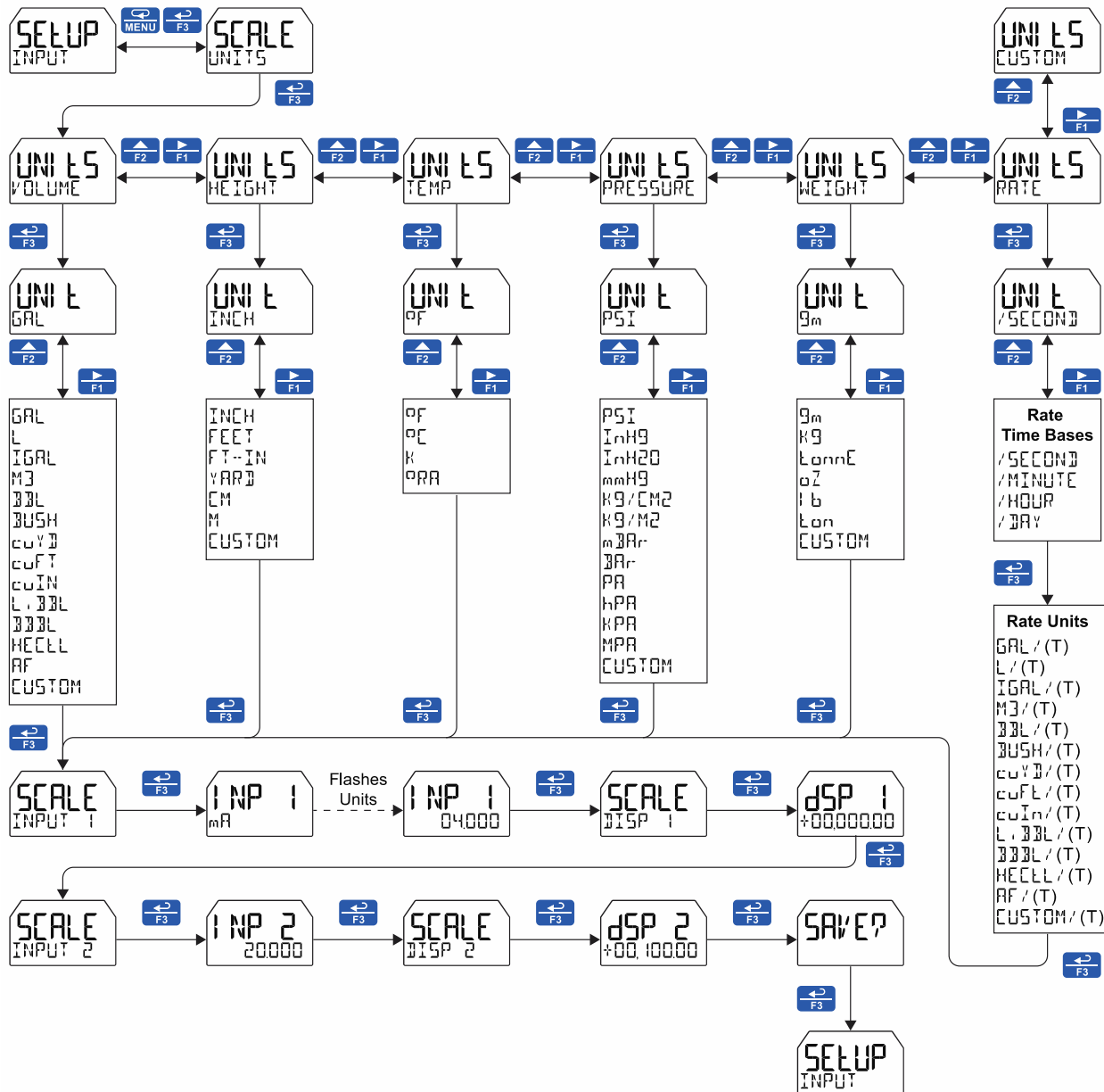

**IMPORTANT**

- **Reverse Scaling**  
The meter can be scaled so that 4 mA represents the high end of the process value range being measured by the transmitter and 20 mA represents the low end of the process value range.

### Available Unit Classes and Units

The meter has six available preprogrammed unit classes: *volume*, *height*, *temperature*, *pressure*, *weight*, and *rate*. Each unit class has the following available units to choose from:

Volume Units (VOLUME)	
GAL	Gallons
L	Liters
IGAL	Imperial Gallons
M3	Cubic Meters
BDL	Barrels
BUSH	Bushels
cuyd	Cubic Yards
cuft	Cubic Feet
cuin	Cubic Inches
L.BDL	Liquid barrels
BBL	Beer barrels
HECLL	Hectoliter
AF	Acre-Foot
CUSTOM	Custom Unit

Height Units (HEIGHT)	
INCH	Inches
FEET	Feet
FT-IN	Feet & Inches
YARD	Yards
CM	Centimeters
M	Meters
CUSTOM	Custom unit

Temperature Units (TEMP)	
°F	Degrees Fahrenheit
°C	Degrees Celsius
K	Kelvin
°RA	Degrees Rankine

Pressure Units (PRESSURE)	
PSI	Pounds per square inch
InHG	Inches of mercury
InH2O	Inches of water
mmHG	Millimeters of mercury
KG/CM2	Kilograms per square centimeter
KG/M2	Kilograms per square meter
mBAR	Millibar
BAR	Bar
PA	Pascal
HPA	Hectopascal
KPA	Kilopascal
MPA	Megapascal
CUSTOM	Custom unit

Weight Units (WEIGHT)	
Gm	Grams
KG	Kilograms
TONNE	Tonnes (metric)
oz	Ounces
lb	Pounds
TON	Tons
CUSTOM	Custom unit

Rate Time Bases (TIME)	
/SECOND	Units per second
/MINUTE	Units per minute
/HOUR	Units per hour
/DAY	Units per day

Rate Units (RATE)	
GAL / (T)	Gallons per time unit (T)
L / (T)	Liters per time unit (T)
IGAL / (T)	Imperial gallons per time unit (T)
M3 / (T)	Cubic meters per time unit (T)
BDL / (T)	Barrels per time unit (T)
BUSH / (T)	Bushels per time unit (T)
cuyd / (T)	Cubic Yards per time unit (T)
cuft / (T)	Cubic Feet per time unit (T)
cuin / (T)	Cubic Inches per time unit (T)
L.BDL / (T)	Liquid barrels per time unit (T)
BBL / (T)	Beer barrels per time unit (T)
HECLL / (T)	Hectoliter per time unit (T)
AF / (T)	Acre-Foot per time unit (T)
CUSTOM /	Custom unit per time unit (T)

### Setting Custom Units (CUSTOM)

When the desired unit class or unit of measure within a class is not available, a custom unit may be programmed. Select the CUSTOM menu (or CUSTOM unit within a unit class) to enter a custom unit name.

Text values are set using the **Right** and **Up-Arrow** buttons. Press **Right-Arrow** to select next character and **Up-Arrow** to increment character value. The selected character will flash. Press and hold the **Up** or **Right-Arrow** buttons to auto-increment or decrement the character. Press **Enter** to accept the character.

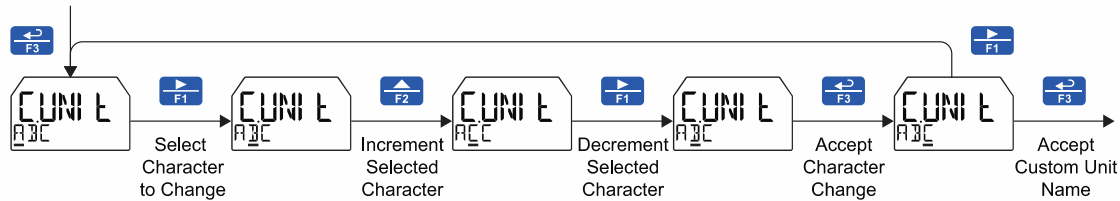

**Notes:**

- Press and hold the **Right-Arrow** while no character is being edited to erase all characters to the right of the flashing character
- Press and hold **Up** or **Right-Arrow** to auto-increment or decrement a selected character.
- All text values, including tags and alarm messages, are set in a similar fashion.

### Setting the Display Features (DISPLAY)

The meter's display functions may be programmed using the *Display* menu. This menu consists of the following submenus: *Units*, *Decimal Point*, *Comma*, *Bargraph*, *Top*, and *Bottom*.

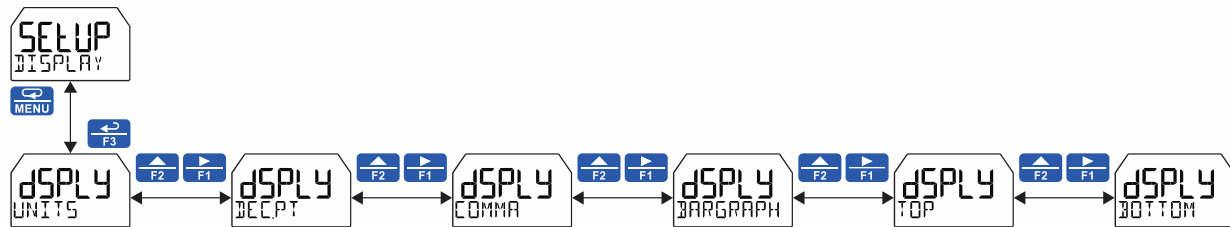

### Changing the Engineering Units (UNITS)

It is possible to change the engineering units within the selected unit class without the need to re-scale the meter. When selecting a new unit from within the DISPLAY menu (e.g. changing from gallons (GAL) to liters (L)), the meter will automatically convert the display values to display the new unit. Enter the UNITS menu, select a new unit of measure from the list of predefined units, and press the **Enter** button. If entering a custom unit (CUSTOM), a custom conversion factor will need to be entered.

### Changing the Decimal Point (DECPT)

The decimal point may be set with up to seven decimal places or with no decimal point at all.

Pressing the **Right-Arrow** moves the decimal point one place to the right until no decimal point is displayed, and then it moves to the left most position. Pressing the **Up-Arrow** moves the decimal point one place to the left.

If the dual-scale level feature is selected, the decimal point selections for PV1 & PV2 are enabled.

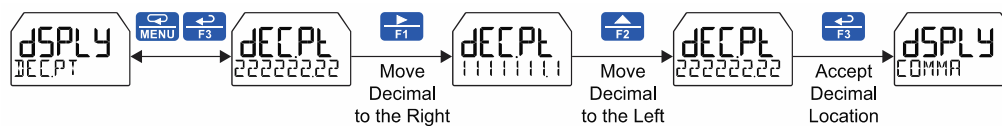

### Enabling or Disabling Commas on the Bottom Display (COMMA)

The bottom display is set to show a comma separating the thousands and millions place by default if a numeric value is being displayed. This feature can be disabled or enabled using the *Comma* menu.



### Display Capabilities Optimization (TOP and BOTTOM)

#### Display Configuration Examples

The meter's dual-line display can be setup in multiple ways to provide an extremely informative view of the process variable being monitored. The following graphics show typical configurations:

**Top Display:** Process Variable  
**Bottom Display:** Engineering Units or Tag

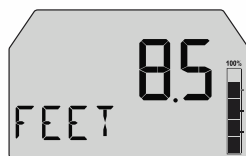

**Top Display:** Process Variable  
**Bottom Display:** Toggling Between Units and Tag

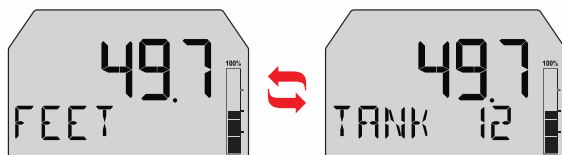

### Dual-Scale Mode:

**Top Display:** Toggling Between Process Variable and Units  
**Bottom Display:** Toggling Between Process Variable (in different scale) and Different Units

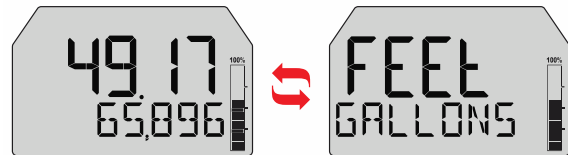

**Note:** To display units as GALLONS, select custom units and enter the desired text.

**Top Display:** Toggling Between Process Variable and Units  
**Bottom Display:** Percent

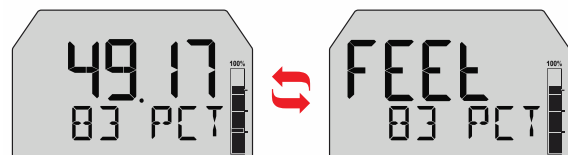

**Top Display:** Maximum Value  
**Bottom Display:** Process Value

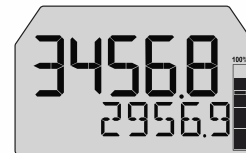

### Configuring the Display (TOP and BOTTOM)

The display is configured using the TOP and BOTTOM menus in the DISPLAY menu. Additional menus are available if the meter is in dual-scale mode to allow the second PV to be displayed on either the top or bottom display.

The top display (TOP) can display:

- Process Value (PV)
- Process Value 2 (dual-scale only; see PV 2 under advanced features menu)
- Alternating PV and Units
- Alternating PV and Tag
- Alternating PV, Units, and Tag
- Tag
- Stopwatch
- Open Collector 1 or 2 Timer
- Relay 1 or 2 Timer
- Minimum Value, Maximum Value, or Both
- Off (Blank)
- Units

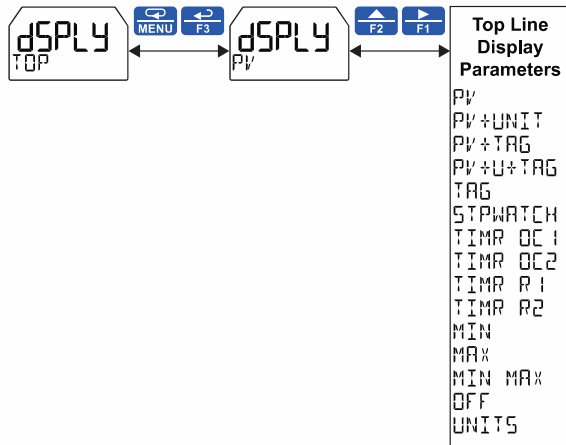

The bottom display (BOTTOM) can display:

- Units
- Process Value (PV)
- Process Value 2 (dual-scale only; see PV 2 under advanced features menu)
- Alternating PV and Units
- Alternating PV and Tag
- Alternating Tag and Units
- Alternating PV, Units, and Tag
- Tag
- Stopwatch
- Open Collector 1 or 2 Timer
- Relay 1 or 2 Timer
- Off (Blank)
- PV's Percentage of Full Scale
- The mA Input
- The mA Output

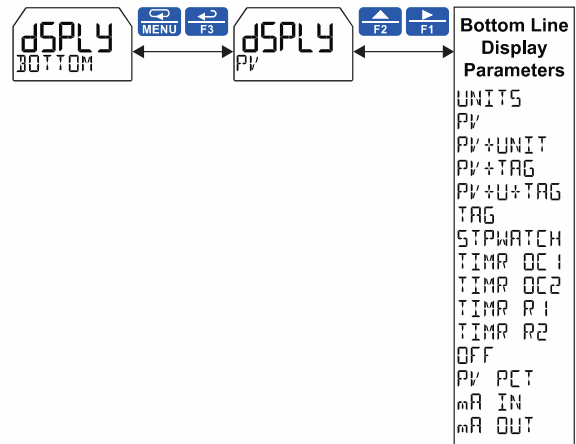

### Programming the Bargraph (BARGRAPH)

The meter comes equipped with a bargraph display for applications where a visual representation of the process variable's percentage of full scale is desirable. This feature can be enabled or disabled using the *Bargraph* menu (BARGRAPH). The value displayed on the bargraph can be the percentage of full scale (PV PCT) or the percentage of a user-programmable range (PV). If the meter is in dual-scale mode, the bargraph can be assigned to display either PV1 or PV2 using this menu.

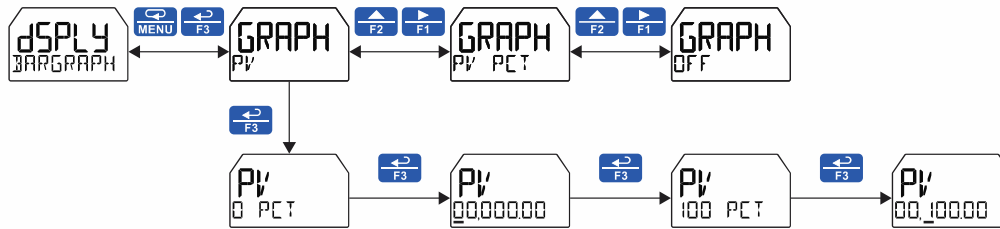

### Programming the Outputs (OUTPUT)

All models come with two open collectors. Depending on the model purchased, the meter may include two solid-state relays, and one 4-20 mA output. The *Output* menu will only show options for the available outputs. See *Ordering Information* on page 11 for details.

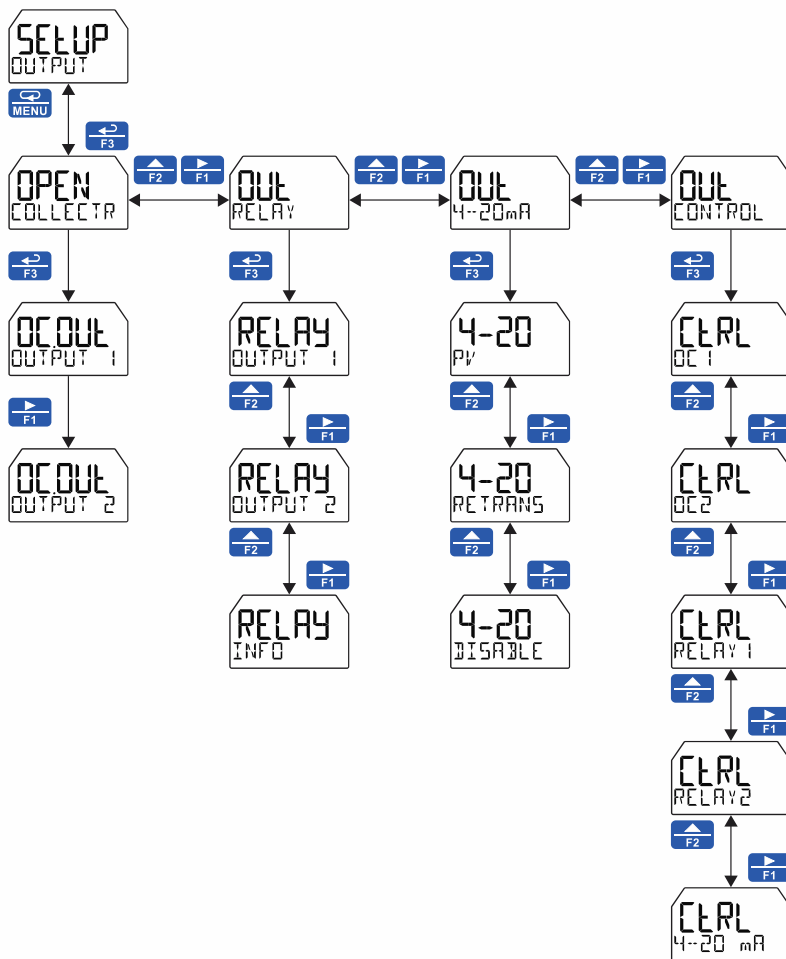

### Open Collector Outputs (OPEN COLLECTR)

The meter is equipped with two NPN open collector outputs as a standard feature that may be set up for pulse outputs, alarms, timed pulses, or disabled.

Pulse outputs can be set to transmit the PV value (PV1 or PV2 if meter is in dual-scale mode). Output 2 may be used to generate a quadrature output based on the other open collector output. An output test mode is also selectable to generate pulses at a constant programmable frequency.

Alarms are available based on the PV value or the digital input. The alarm status will show on the display even if the output is not wired.

A timer output (TIMER) turns the open collector on and off at the specified time intervals. The timer can be set as single-shot or continuous timer.

The stopwatch output (STPWATCH) allows the open collector to be manually activated by starting the stopwatch. The stopwatch count can be displayed on the top or bottom display.

The output may be disabled by selecting **DISABLE**.

The Open Collector Outputs are programmed in the following manner:

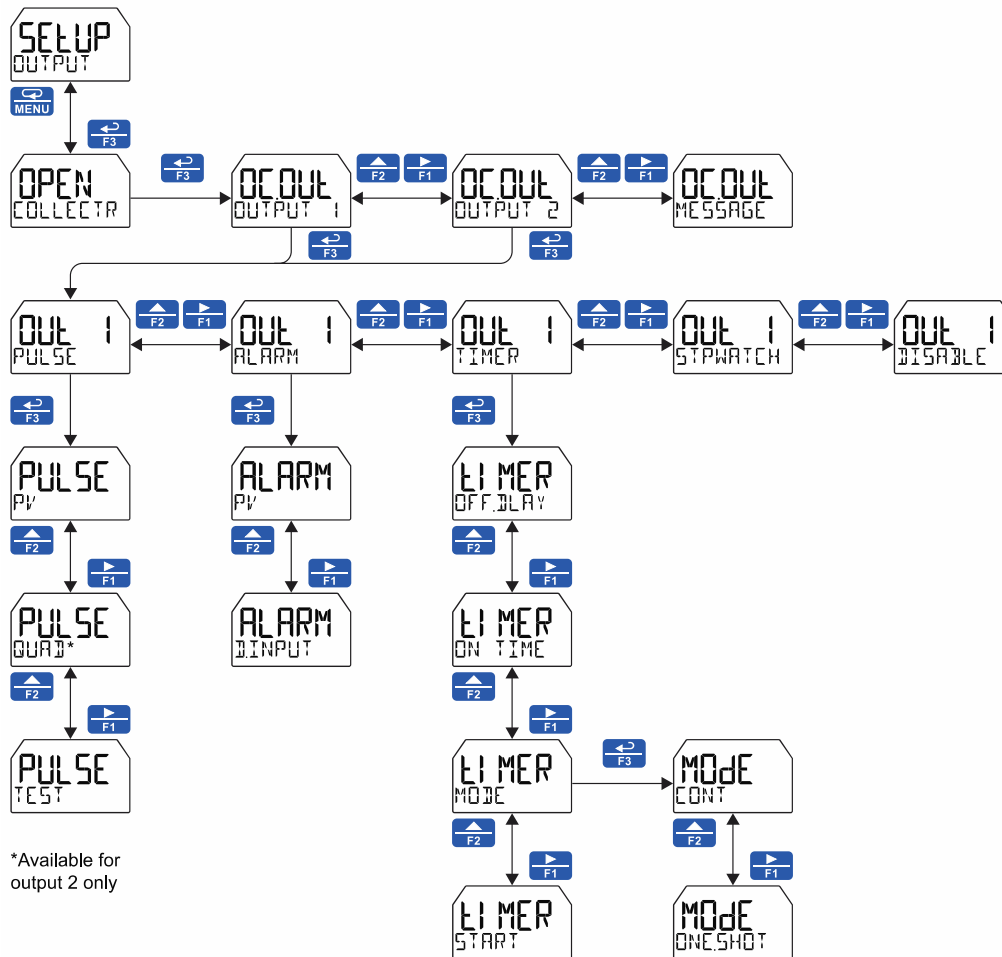



### Pulse Output (PULSE)

The pulse outputs may be programmed to generate a scaled frequency based on the PV and a programmable factor. The factor determines the number of pulses per second generated per unit of measure. For example, if the meter display shows 100 gallons and the factor is set to 2, the number of pulses generated per second would be 200. The maximum frequency is 1,000 Hz.

Setting output 2 to quadrature will duplicate the other open collector output, but lag by 90 degrees out of phase. The other output should be programmed as desired for the quadrature output function and must be a pulse (PULSE) output selection. The quadrature maximum frequency for both outputs is 500 Hz.

The TEST option will output a fixed number of pulses per second based on the FREQ value entered.

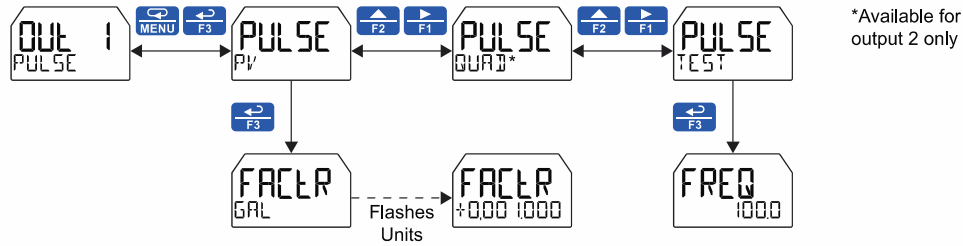

### Alarm (ALARM)

Alarm outputs may be assigned to the PV or the digital input. When assigned to the PV, the alarm may be set as either a high alarm or a low alarm. Alarm actions (AUTO, AUTOMAN, LATCH, L--CLEAR) determine how and when the alarm should be reset. They operate as follows:

- **Automatic (AUTO):** Alarm will reset automatically once the alarm condition has cleared.
- **Automatic/Manual (AUTOMAN):** Alarm will reset automatically once the alarm condition has cleared but can also be reset using the **Enter** (ACK) button (or whichever function key is set to acknowledge) at any time.
- **Latching (LATCH):** Alarm must be reset manually and can be done so at any time. Press the **Enter** (ACK) button at any time to clear the alarm.
- **Latching with Reset after Clear (L--CLEAR):** Alarm must be reset manually and can only be done so after the alarm condition has cleared. Press the **Enter** (ACK) button after the alarm condition has cleared to reset the alarm.

If the alarm is set to PV, a set and reset point must be programmed. The set point is the display value at which the alarm will turn on and the reset point is the display value at which the alarm will turn off. If the set point is lower than the reset point, the alarm will be a low alarm; if the set point is higher than the reset point, the alarm will be a high alarm. The digital input alarm will trigger whenever the digital input is triggered.

For both the PV and digital input alarms, a delay before the alarm is turned on or off may be set, as well as a fail-safe feature which reverses the on/off operation of the open collectors.

Alarm states will be displayed on the meter even if no open collector output is physically connected. These may include a red LED backlight, flashing PV value (PV alarm only), a programmable alarm message, an alarm indicator ▲, and flashing bargraph segment.

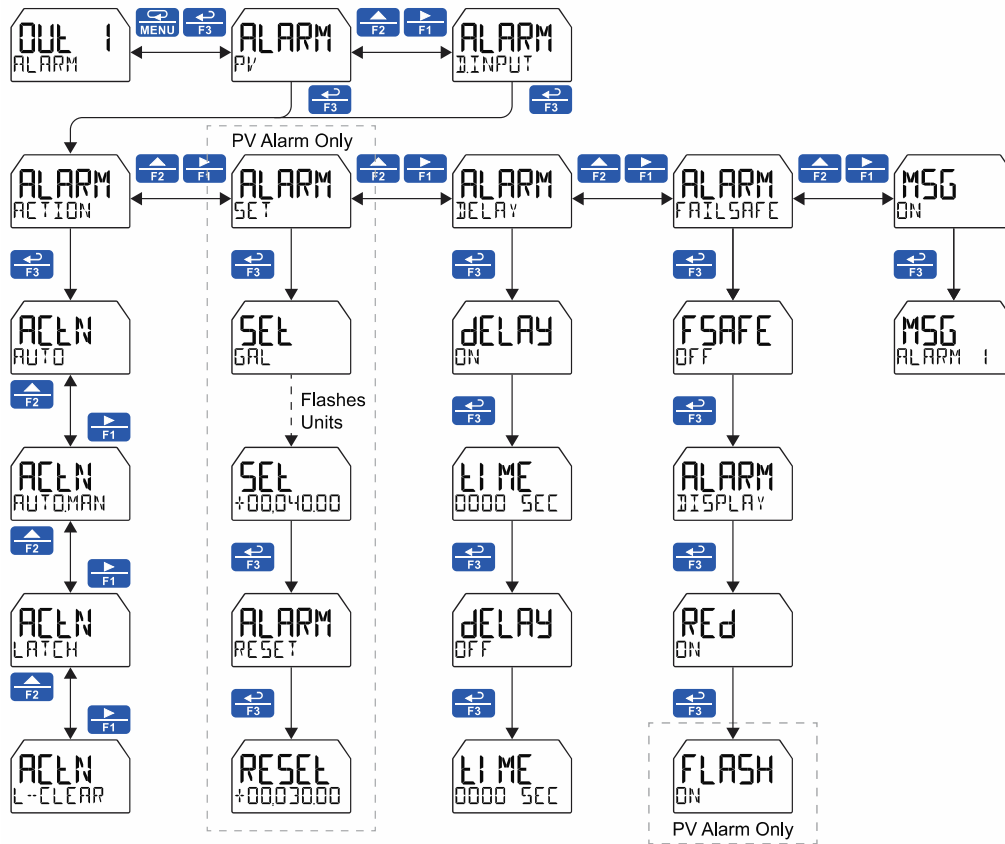

### Flashing Red Alarm (RED)

The last two lines in the preceding menu flow chart show how to program the display to turn red, flash, and display a message when an alarm occurs.



Alarm 1 is High Alarm



Alarm 2 is Low Alarm

### Timer (TIMER)

The timer output may be set to generate the timed pulse only once (ONESHOT) or continuously (CONT).

The timer output produces a constant width pulse at a constant frequency, if set as continuous timer. Program the *Off Delay* (OFF DELAY) from 1 second to 99 hours 59 minutes and 59 seconds. This is the time it takes from selecting START to turning on the output and for how long the output is off in continuous mode.

Program the *On Time* (ON TIME) for the active low pulse from 1 second to 99 hours 59 minutes and 59 seconds (pulse width). This is the period of time for which the output will remain on.

Select *Start* (START) to begin outputting the constant timed pulse.

Select *Stop* (STOP) to end outputting the constant timed pulse.

Function keys or the digital input may be assigned to start and stop timer functions (see the USER menu in the *Advanced Menu*).

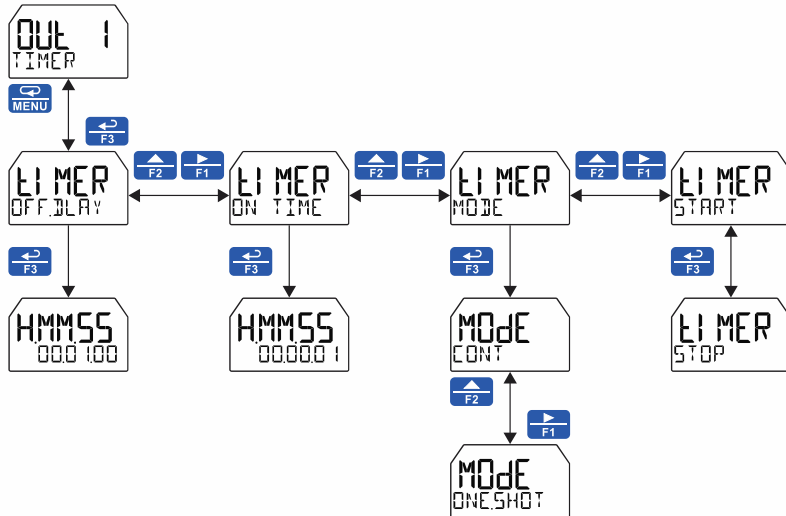

## Stopwatch (STPWATCH)

The stopwatch function may be used to manually run and control a process for a specific time interval up to 99 hrs., 59 min, and 59 seconds. The stopwatch function may be assigned to any open collector. There are three settings needed to use the function effectively.

1. Assign stopwatch to either top or bottom display
2. Assign the open collector to control the process (on/off)
3. Assign a function key or digital input to start/stop the stopwatch

### Application Example

To maintain consistency of a product, it is necessary to take and test samples at different times throughout the day. The stopwatch function is used to open and close a solenoid valve to know the exact amount of time needed to complete the desired sample. Once this is determined, the timer function can be used to automatically take a sample (batch) based on the time determined using the stopwatch function.

**Setup:** Assign the following to *Stopwatch Function*

- Bottom display  
(see pages 36 & 38 for details how to change the display)
- Relay 1  
(see pages 39 & 45 how to change Open Collector and Solid-State Relay functionality)
- F3: Start/Stop  
(see pages 61 & 62 for details on how to change the function keys)

### Procedure

- Press F3 to start the stopwatch; relay 1 turns on and the process starts running.
- Press F3 to stop the stopwatch; relay 1 turns off and the process stops.
- The bottom display indicates the time it took to complete the sample.

### Solid-State Relay Outputs (RELAY)

The meter can be optionally equipped with two solid-state relays that may be set up for alarms, timer, stopwatch, or pump control. Alternatively, they may be disabled.

Alarms are available based on the PV value or the digital input. The alarm status will show on the display even if the output is not wired.

Pump control allows the relay to turn on and off a pump at specified on and off points. This can be done using only one of the relays to control one pump (ON-OFF) or using both relays in tandem to alternate between two pumps (ALTERN).

A timer output (TIMER) turns the relay on and off at the specified time intervals. The timer can be set as single-shot or continuous timer.

The stopwatch output (STOPWATCH) allows the relay to be manually activated by starting the stopwatch. The stopwatch count can be displayed on the top or bottom display.

The output may be disabled by selecting **DISABLE**.

**CAUTION**

- During setup, the relays do not follow the input and they will remain in the state found prior to entering the Relay menu.

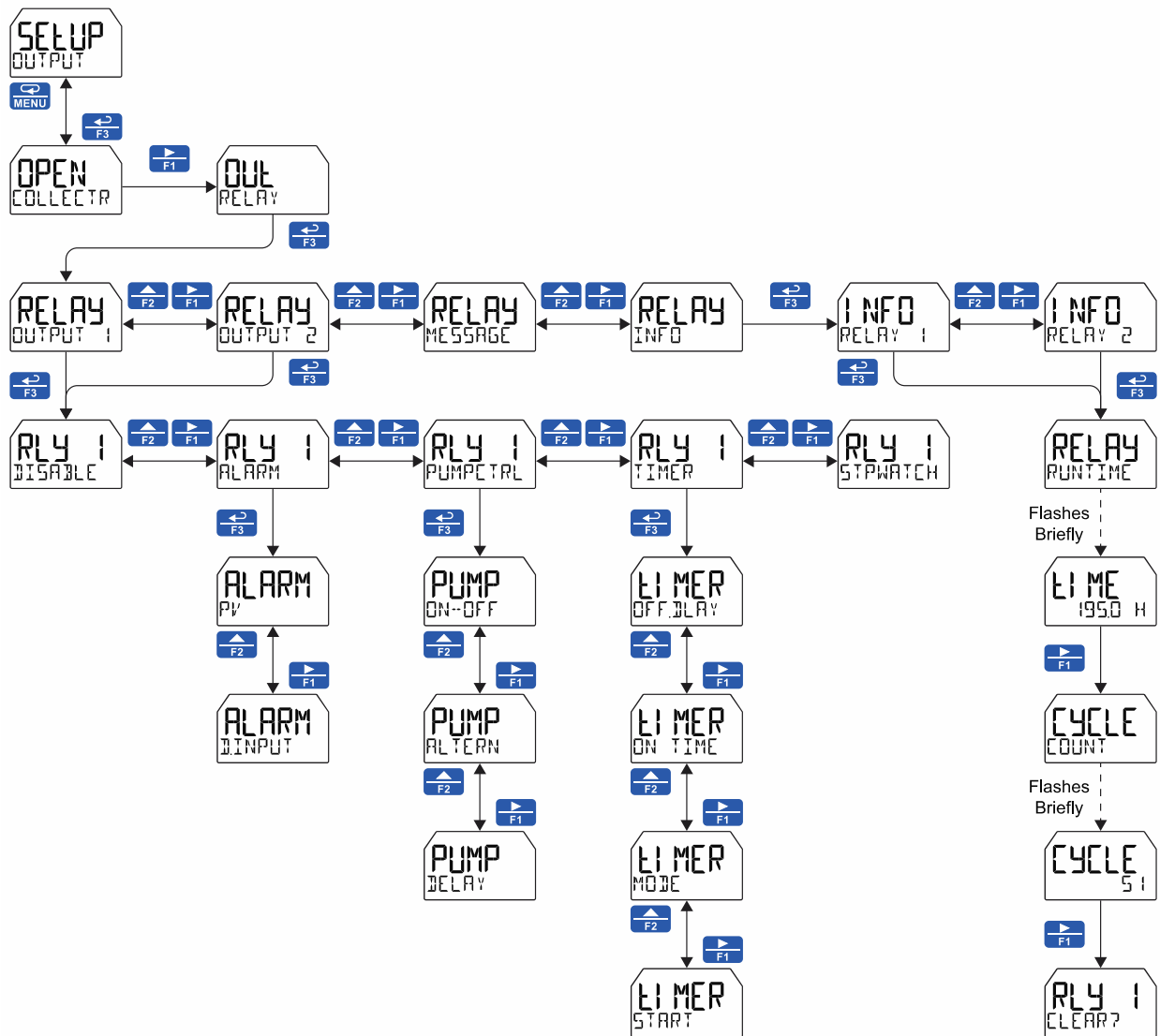

### Alarm (ALARM)

Alarm outputs may be assigned to the PV or the digital input. When assigned to the PV, the alarm may be set as either a high alarm or a low alarm. Alarm actions (AUTO, AUTOMAN, LATCH, L-CLEAR) determine how and when the alarm should be reset. They operate as follows:

- **Automatic (AUTO):** Alarm will reset automatically once the alarm condition has cleared.
- **Automatic/Manual (AUTOMAN):** Alarm will reset automatically once the alarm condition has cleared but can also be reset using the **Enter** (ACK) button (or whichever function key is set to acknowledge) at any time.
- **Latching (LATCH):** Alarm must be reset manually and can be done so at any time. Press the **Enter** (ACK) button at any time to clear the alarm.
- **Latching with Reset after Clear (L-CLEAR):** Alarm must be reset manually and can only be done so after the alarm condition has cleared. Press the **Enter** (ACK) button after the alarm condition has cleared to reset the alarm.

If the alarm is set to PV, a set and reset point must be programmed. The set point is the display value at which the alarm will turn on and the reset point is the display value at which the alarm will turn off. If the set point is lower than the reset point, the alarm will be a low alarm; if the set point is higher than the reset point, the alarm will be a high alarm. The digital input alarm will trigger whenever the digital input is triggered.

For both the PV and digital input alarms, a delay before the alarm is turned on or off may be set, as well as a fail-safe feature which reverses the on/off operation of the relays.

Alarm states will be displayed on the meter even if no relay output is physically connected. These may include a red LED backlight, flashing PV value (PV alarm only), and a programmable alarm message. In addition, for meters without a bargraph an alarm indicator (!) (only on meters with no bargraph) will also display.

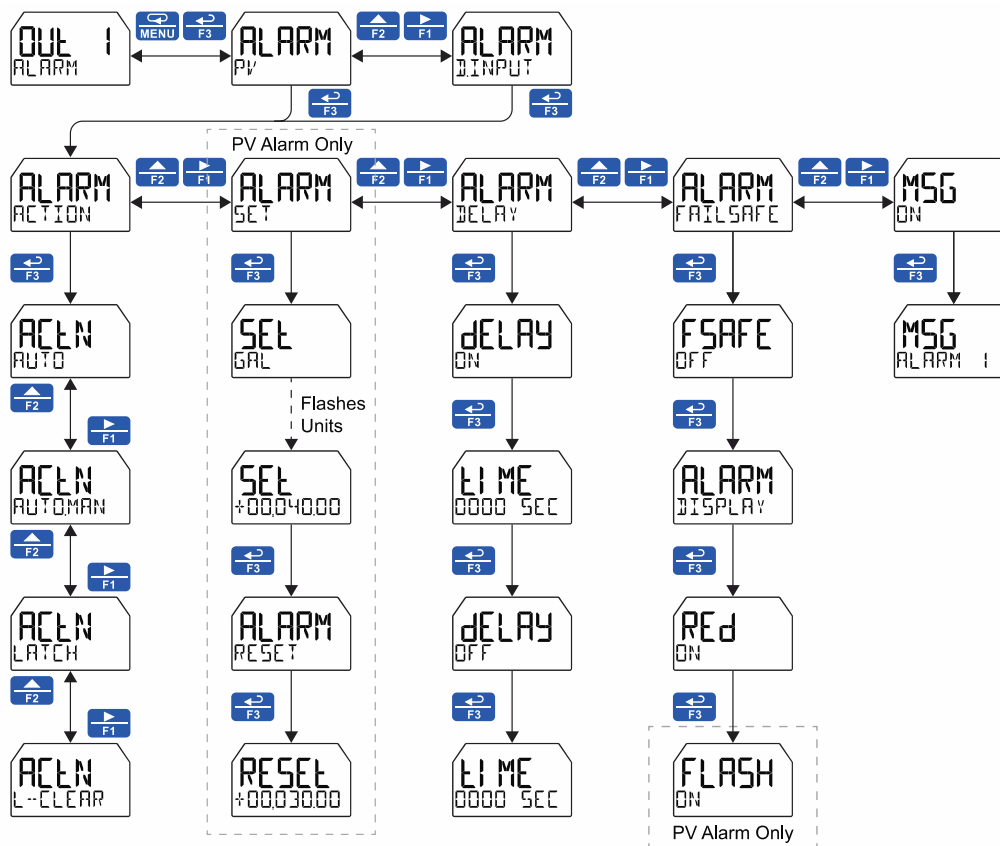

### Pump Control (PUMPCTRL)

The pump control output is used in situations where the relays are used to control pumps. There are two options available for controlling pumps: on-off (ON-OFF) and pump alternation (ALTERN).

ON-OFF will turn the relay on at a programmed on point and off at a programmed off point. Setting the on point higher than the off point will make the output activate on a high PV value; setting the on point lower than the off point will make the output activate on a low PV value. The relay will reset automatically.

For pump control applications where two similar pumps are used to control the level of a tank or a well, it may be desirable to have the pumps operate alternately. This prevents excessive wear and overheating of one pump over the lack of use of the other pump. Pump alternation uses both relays in tandem to alternate between two similar pumps. The ALTERN menu is only available under Output 1 and will automatically set Output 2 to pump alternation as well. Use the pump *Alternation Time* setting (ALTIME) to control the alternation based on runtime in addition to level cycles.

### On/Off Pump Control (ON-OFF)

When programming a single pump to turn on and off, the on and off points must be programmed. The relay will activate at the on point and deactivate at the off point. On and off delays may be programmed to delay the activation or deactivation of the relay by a certain number of seconds after reaching either the on point or off point.

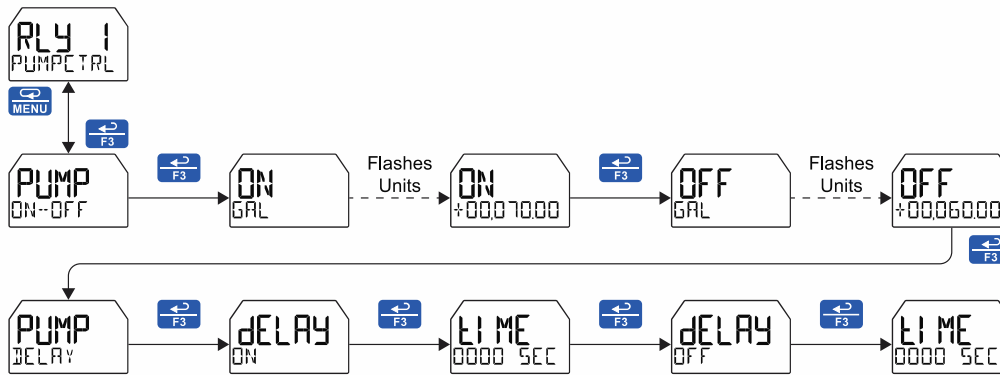

### Pump Alternation (ALTERN)

Pump alternation sets the two relays to alternate every time the first *on* point (ON 1) is reached. The active relay will turn off once the first *off* point (OFF 1) is reached. If the PV reaches the second *on* point (ON 2), the other relay will also turn on. The second relay will turn off once the second *off* point (OFF 2) is reached and the first relay will remain active until the first *off* point (OFF 1) is reached.

On and off delays may optionally be programmed for each *on* and *off* point to delay the activation or deactivation of the relays by a certain number of seconds after reaching either the *on* point or *off* point.

For pumps that typically remain on extensively, the alternation time (ALTTIME) parameter sets a period of relay on-time after which the relays should alternate. For example, if the alternation time is set to one hour, pump 1 will turn off after one hour of runtime regardless of the level reading, at which point pump 2 becomes the active pump. Pump 2 will run until one hour has passed, or the tank has reached a desirable level; whichever happens first. By using the proper on/off points, the alternation can be set up so that the first pump on is the first pump off. This is desirable when the two pumps are of similar rating.

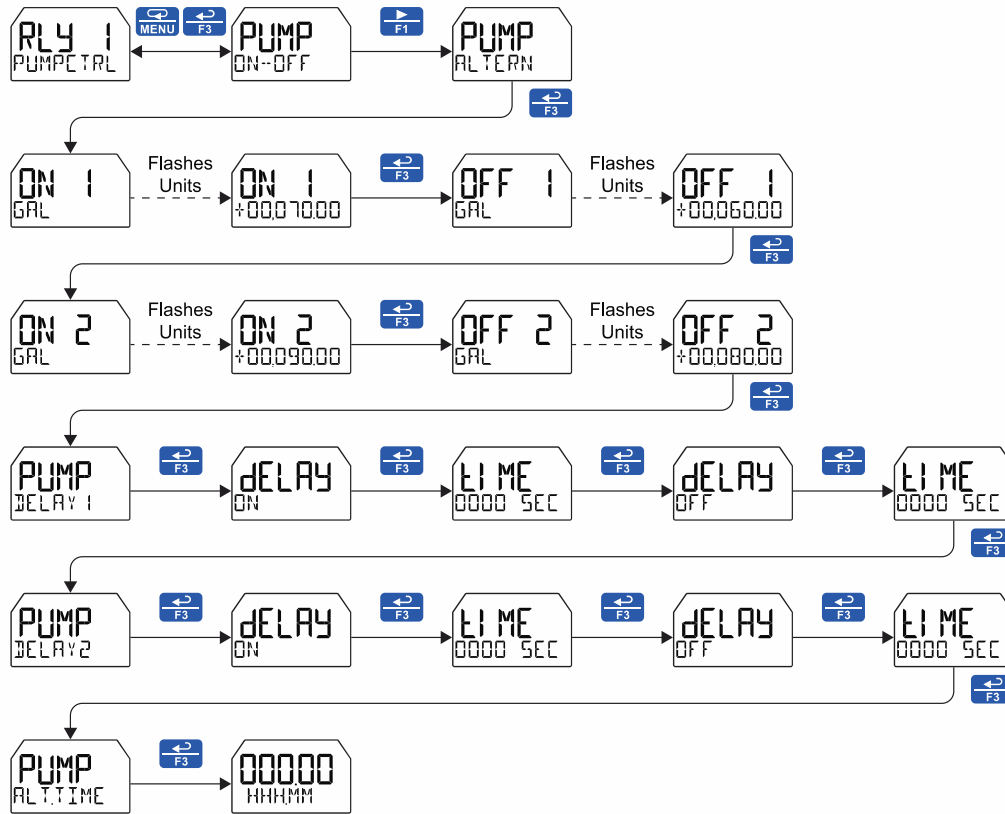



### Pump Control with Alternation & Alarm Example

The following is a typical application where the relays and open collectors are used for pump alternation and high and low level alarm.

#### Pump and Alarm On & Off Point Programming

Relay	On Point	Off Point	Function
1	7000	2000	Controls backup pump
2	6000	2000	Controls main pump

OC	On Point	Off Point	Function
1	7000	6500	Trips high alarm
2	1000	1500	Trips low alarm

The following graphics provide a visual representation of a typical pump alternation application:

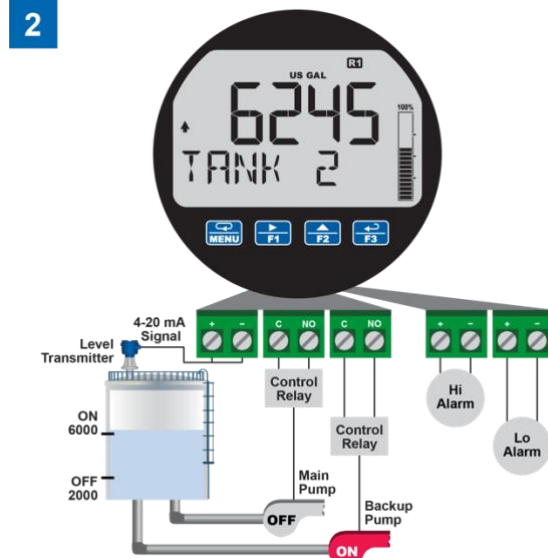
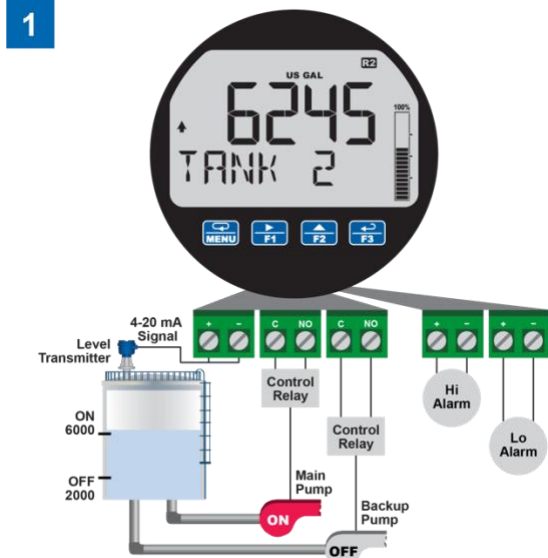

Relay #2 turns the main pump on at 6000 gallons and turns it off at 2000 gallons. R2 lights up to show relay 2 is energized. The ▲ indicates level is rising.

With the Pump Alternation feature activated, the next time the level reaches 6000 gallons, relay #1 transfers and starts the backup pump. R1 lights up to show relay 1 is on.

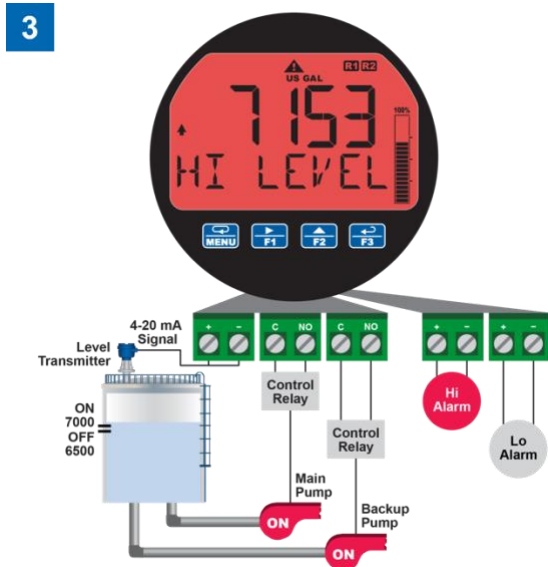

If the backup pump is not able to keep up, and the level reaches 7000 gallons, relay #2 transfers and starts the main pump as well. Open collector #1 trips the High Level Alarm, the display turns red and flashes "Hi Level" message, and ▲ indicates an alarm condition. The High Level Alarm resets at 6500 gallons.

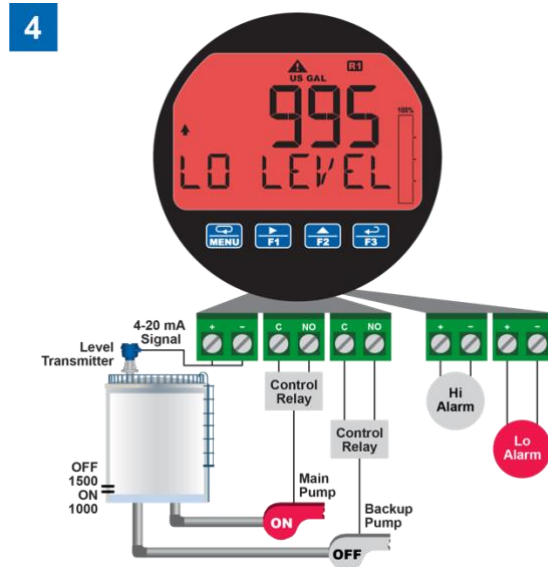

Once the level has dropped below the reset points, both relays will turn off. If the Main Pump fails to turn off, open collector #2 trips the Low Level Alarm at 1000 gallons to warn against the pump running dry. The Low Level Alarm resets at 1500 gallons.

### Timer (TIMER)

The timer output may be set to generate the timed pulse only once (ONESHOT) or continuously (CONT). The timer output produces a constant width pulse at a constant frequency, if set as continuous timer.

Program the *Off Delay* (OFFDELAY) from 1 second to 99 hours 59 minutes and 59 seconds. This is the time it takes from selecting START to turning on the output and for how long the output is off in continuous mode.

Program the *On Time* (ONTIME) for the active low pulse from 1 second to 99 hours 59 minutes and 59 seconds (pulse width). This is the period of time for which the output will remain on.

Select *Start* (START) to begin outputting the constant timed pulse. Select *Stop* (STOP) to end outputting the constant timed pulse. Function keys or the digital input may be assigned to start and stop timer functions (see the USER menu in *Advanced*).

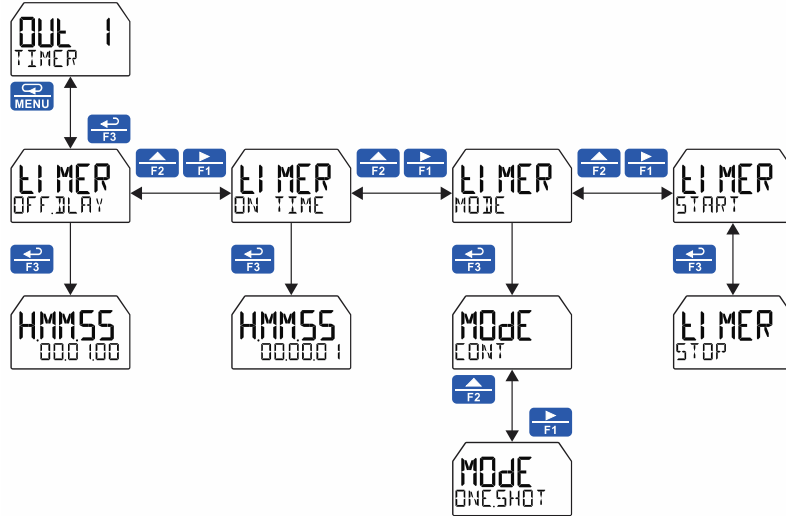

### Stopwatch (STWATCH)

The stopwatch function may be used to manually run and control a process for a specific time interval up to 99 hrs., 59 min, and 59 seconds. The stopwatch function may be assigned to any relay. There are three settings needed to use the function effectively.

1. Assign stopwatch to either top or bottom display
2. Assign the relay to control the process (on/off)
3. Assign a function key or digital input to start/stop the stopwatch

#### Application Example

To maintain consistency of a product, it is necessary to take and test samples at different times throughout the day. The stopwatch function is used to open and close a solenoid valve to know the exact amount of time needed to complete the desired sample. Once this is determined, the timer function can be used to automatically take a sample (batch) based on the time determined using the stopwatch function.

**Setup:** Assign the following to *Stopwatch Function*

- Bottom display  
(see pages 36 & 38 for details how to change the display)
- Relay 1  
(see pages 39 & 45 how to change Open Collector and Solid-State Relay functionality)
- F3: Start/Stop  
(see pages 61 & 62 for details on how to change the function keys)

#### Procedure

- Press F3 to start the stopwatch; relay 1 turns on and the process starts running.
- Press F3 to stop the stopwatch; relay 1 turns off and the process stops.
- The bottom display indicates the time it took to complete the sample.

### Runtime & Cycle Count (INFO)

The relay information menu shows runtime and cycle count for each relay. These values may be cleared at any time by selecting the *Clear* option (CLEAR?).

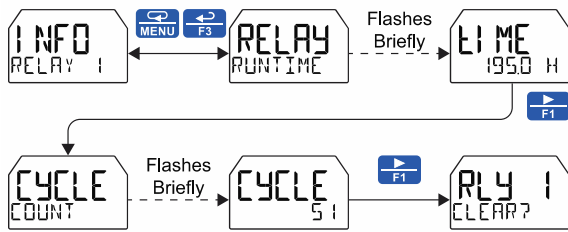

### Isolated 4-20 mA Output (4-20 mA)

The 4-20 mA menu is used to scale the isolated 4-20 mA output based on display values. This menu is not present on models without a 4-20 mA output option.

The 4-20 mA analog output can be scaled to provide a 4-20 mA signal for any PV display range or to simply retransmit the 4-20 mA input. The output may be disabled (DISABLE), and will only output the minimum signal.

Overrange and underrange values determine what mA signal the meter will output if the mA input is underrange (<3.5 mA) or overrange (>20.5 mA). This value may be set to 1 mA, 3.5 mA, 3.8 mA, 20.5 mA, 20.8 mA, 23 mA, or disabled.

No equipment is needed to scale the analog output; simply program two display values and corresponding mA output signals.

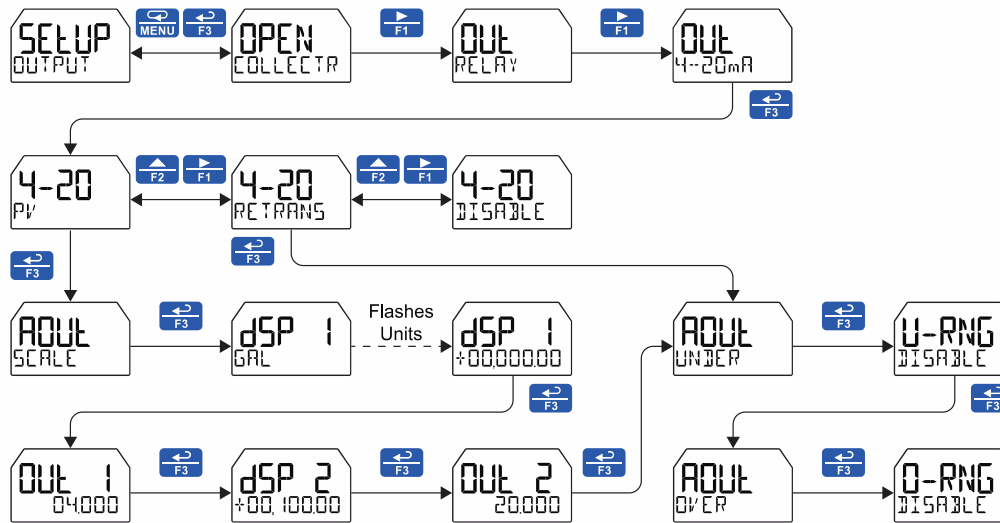

### Process Variable (PV)

To scale the analog output, enter display value 1 and a corresponding analog output value for this display, and enter display value 2 and a corresponding analog output value for this display value. This will provide a scaled linear analog output.

### Retransmit (RETRANS)

This option will retransmit the 4-20 mA analog input without the need to scale the output.

### Output Manual Control (CONTROL)

The *Control* menu is used to control the open collector outputs, 4-20 mA analog output, and the relays manually, ignoring the input. Each open collector, relay, and analog output can be programmed independently for manual control. Selecting automatic control sets all relays and analog output for automatic operation.

After selecting manual control for a specific output, you can set the output value. To change the output value, return to the Control menu, select the output to control, select manual control, and enter a new value.

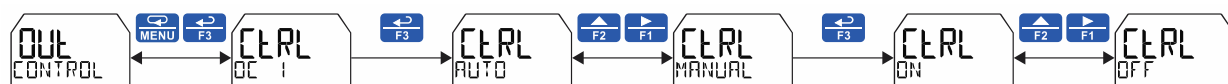

## Advanced Features Menu (ADVANCE)

To simplify the setup process, functions not needed for most applications are located in the *Advanced Features* menu. The options under advanced features include *advanced PV setup, cutoff, filter, password, function key programming, and system settings.*

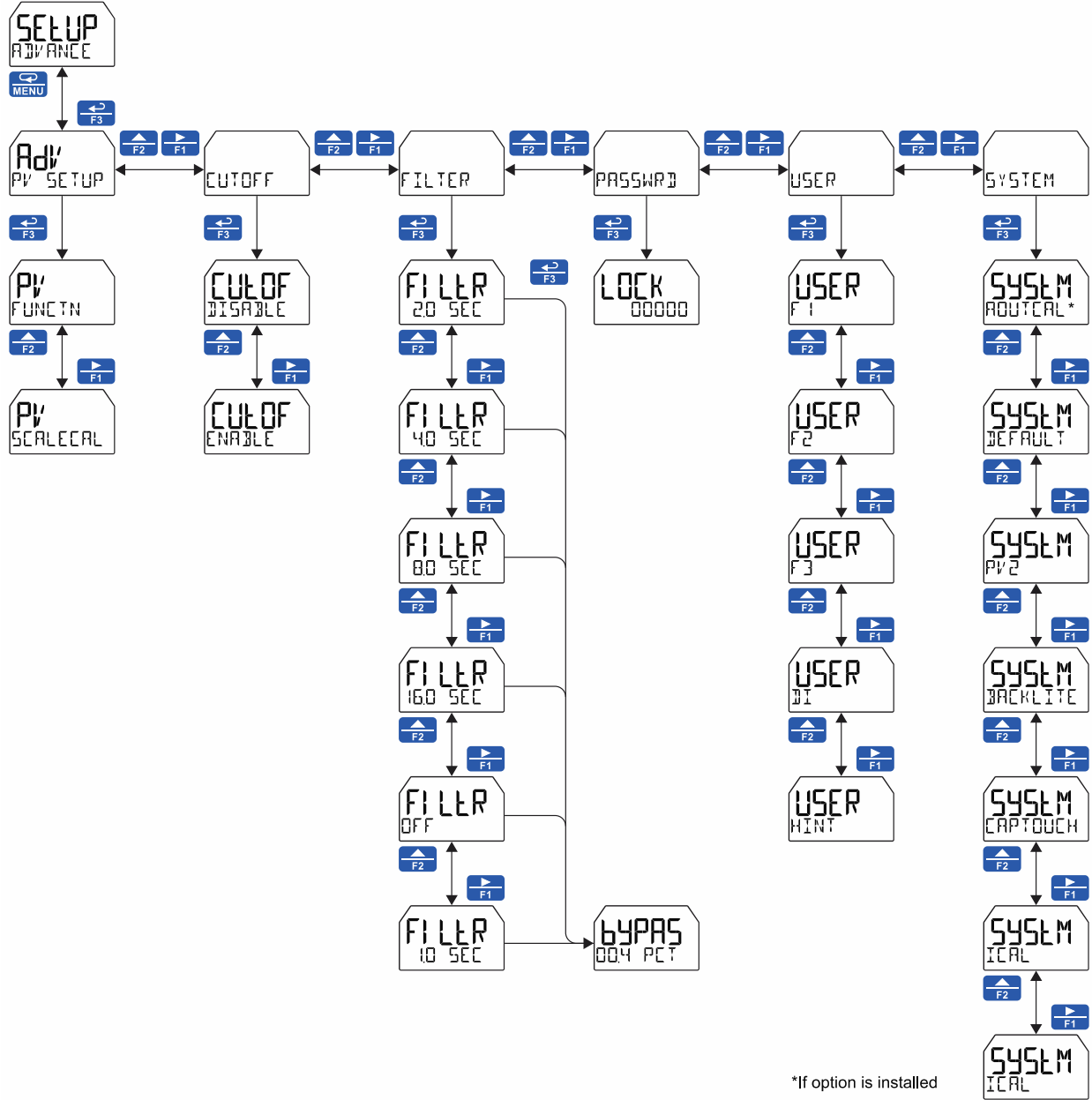

### Advanced Process Variable Setup (ADV PV SETUP)

The Advanced PV Setup menu contains options to apply input signal conditioning functions to the input and to scale/calibrate the input signal.

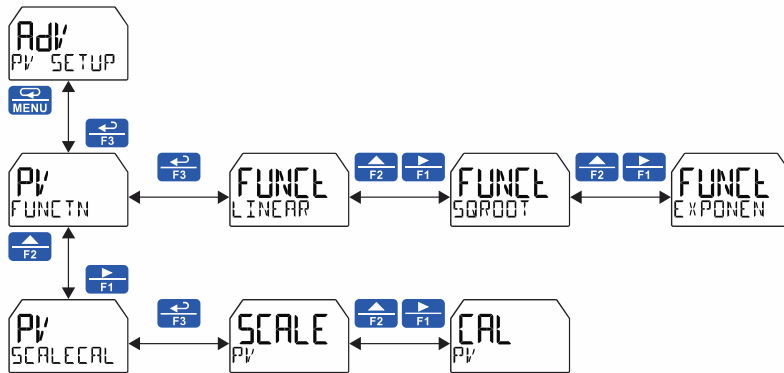

### Input Signal Conditioning Functions (FUNCTN)

The *Function* menu is used to select the input signal conditioner applied to the input: linear, square root, programmable exponent, or round horizontal tank volume calculation. Multi-point linearization is part of the linear function selection.

Meters are set up at the factory for linear function with 2-point linearization. The linear function provides a display that is linear with respect to the input signal.

#### Using MeterView XL

MeterView XL makes programming the input signal conditioning functions quick and easy. Go to the input/scale menu and select the desired function from the drop down menu in the “scale input” section.

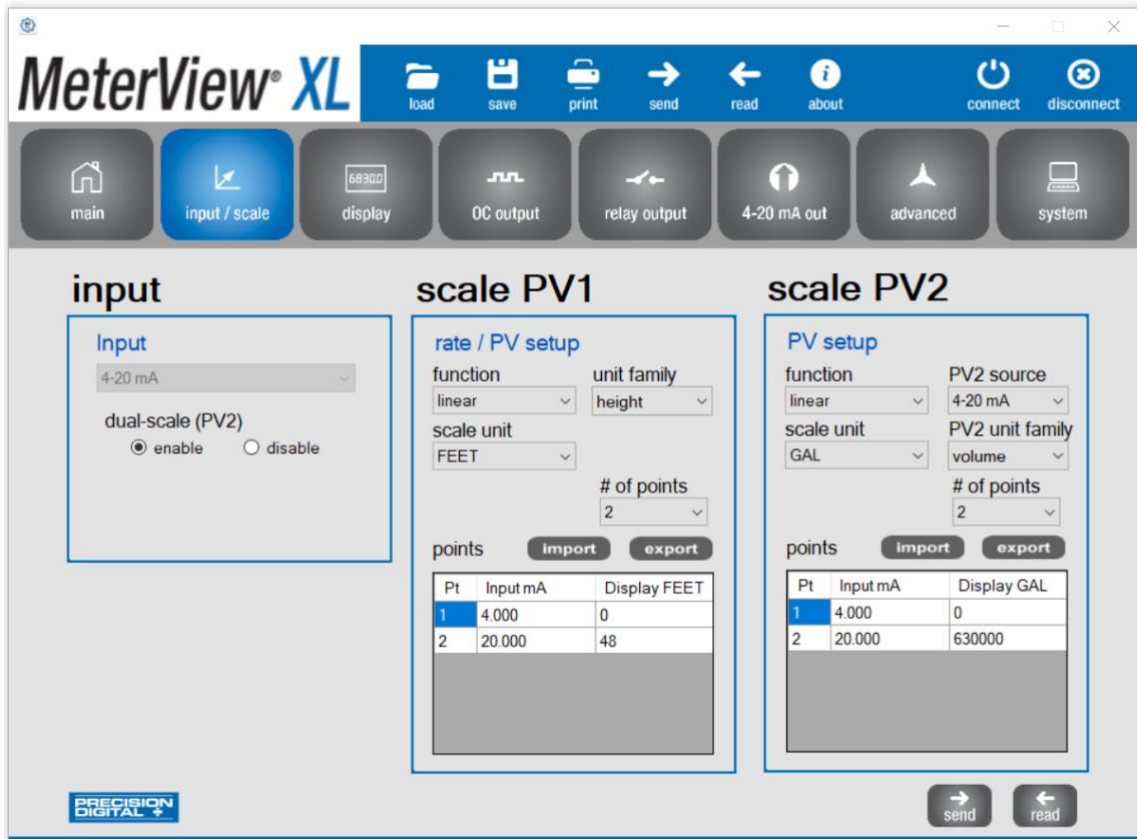

### Square Root Linearization (SQROOT)

The square root function can be used to linearize the signal from a differential pressure transmitter and display flow rate in engineering units.

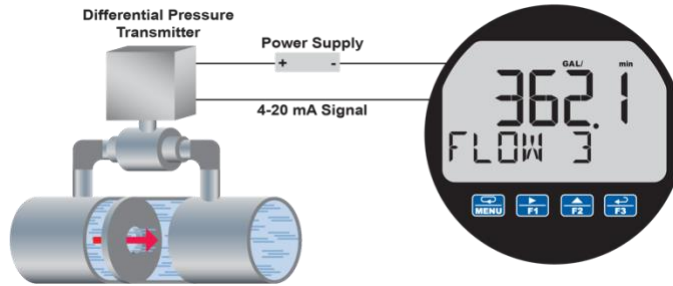

PD6908 Displaying Flow Rate by Applying the Square Root Function to the Output of a DP Transmitter.

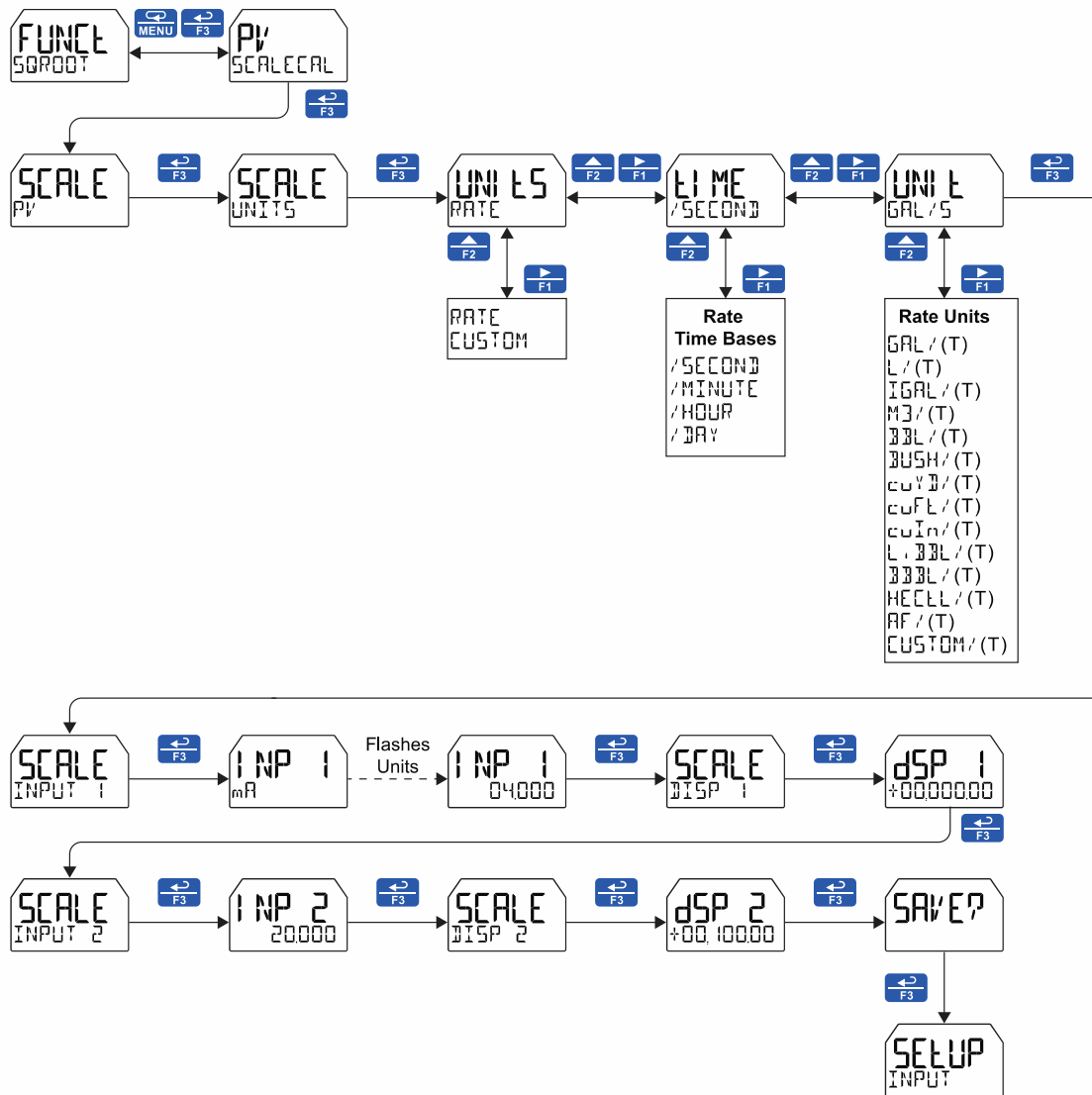

**Programmable Exponent Linearization (EXPONEN)**

The programmable exponent can be used to linearize the signal from level transmitters in open-channel flow applications using weirs and flumes.

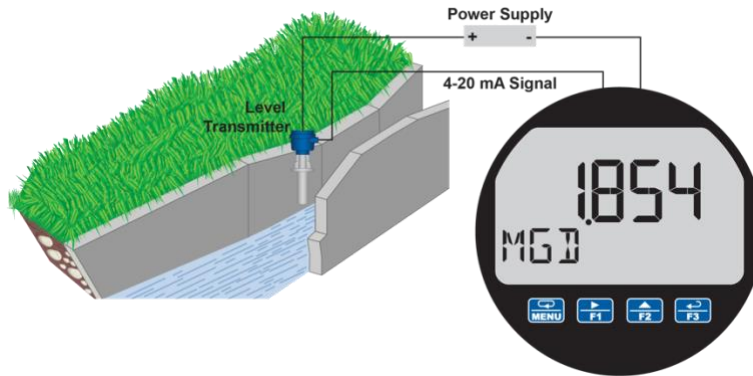

The PD6908, in combination with an ultrasonic level transmitter, makes for an economical way to measure and display open channel flow rate in most weirs and flumes. A guide such as the ISCO Open Channel Flow Measurement Handbook can provide the user with all the information needed: the exponent used in the flow equation for the desired flow units and the flow rate for any given head height. For example, to display the open channel flow rate from a 3" Parshall flume, the ISCO handbook advises the exponent is 1.547 and at the maximum head height of 3.0 feet, the flow rate is 3.508 MGD.

3" Parshall Flume Discharge Table			
Formula:	CFS	= 0.9920 H <sup>1.547</sup>	
	GPM	= 445.2 H <sup>1.547</sup>	
	MGD	= 0.6411 H <sup>1.547</sup>	
Where:	H	= Head in feet	
Table 12-3			
Head (Feet)	CFS	GPM	MGD
3.00	5.428	2436	3.508
<i>ISCO Open Channel Flow Measurement Handbook, 3<sup>rd</sup> edition</i>			

With this information the PD6908 should be programmed in the following fashion. This setup assumes the level transmitter is programmed to output 20 mA at the maximum head height of 3.00 feet; but any mA value at a head height with a known flow rate may be used.

Function	Desired	Programming
Open Channel Flow	3" Parshall flume	Set Programmable Exponent to 1.547
Flow Rate	Millions of Gallons per Day (MGD)	Set 4 mA = 0 20 mA = 3.508
Display	Display Flow Rate	Set upper display for flow rate display and lower display units/tag for MGD.

To display both flow rate and total, consider Precision Digital's Model PD6928 Flow Rate Totalizer.

The Programmable Exponent function is programmed in the following manner:

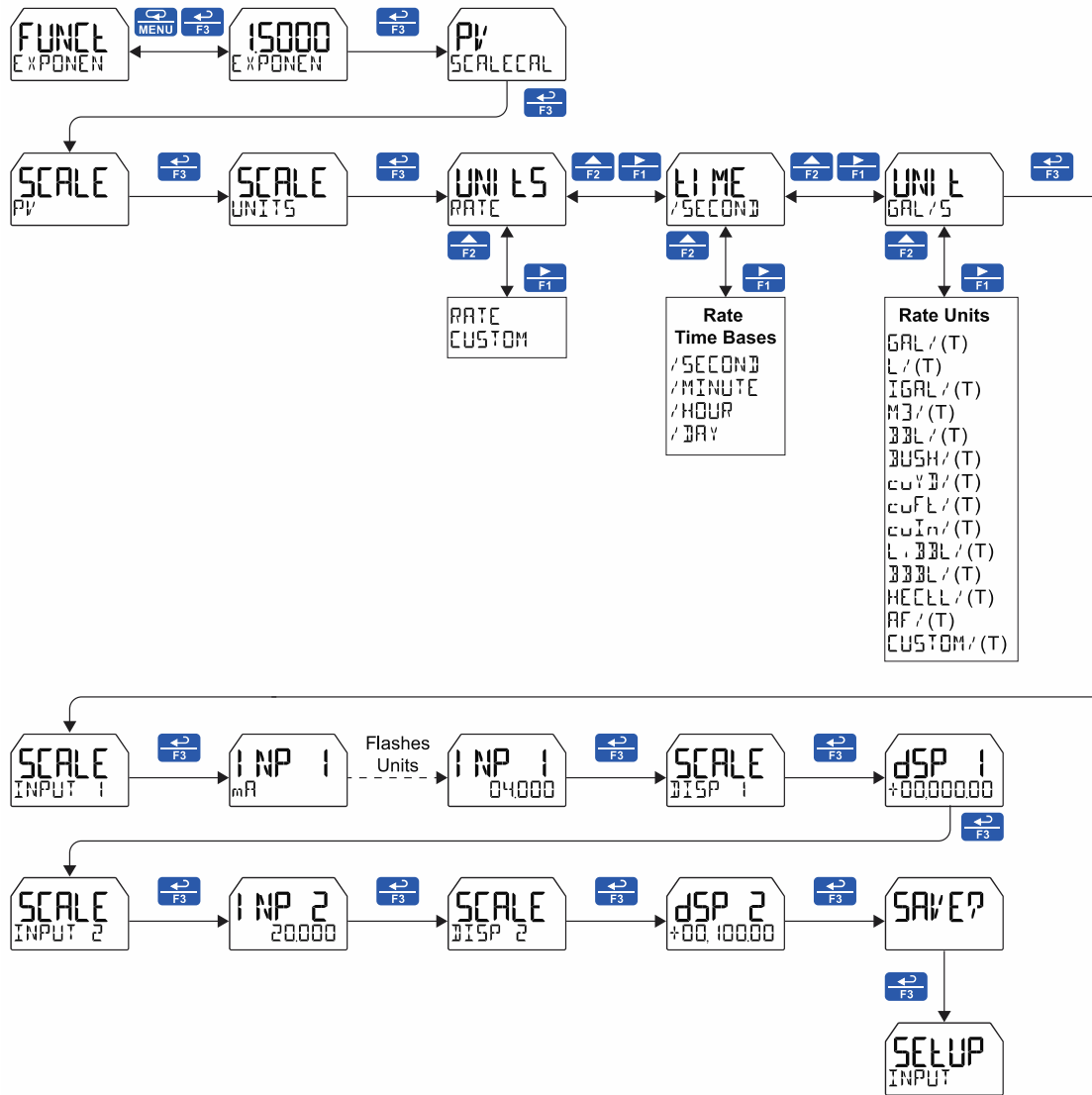



### Multi-Point Linearization (LINEAR)

Up to 32 linearization points can be selected for PV1 and PV2 under the LINEAR function. Multi-point linearization can be used to linearize the input so the meter can display volume from non-linear tanks or to convert level to flow using weirs and flumes with complex equations. These points are established via direct entry (SCALE) or with a live calibration signal source (CAL).

If the dual-scale level feature has been selected, the menus for PV1 & PV2 are enabled.

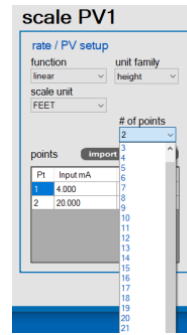

MeterView XL showing the linear points setup feature. Up to 32 points can be selected for PV1 and PV2.

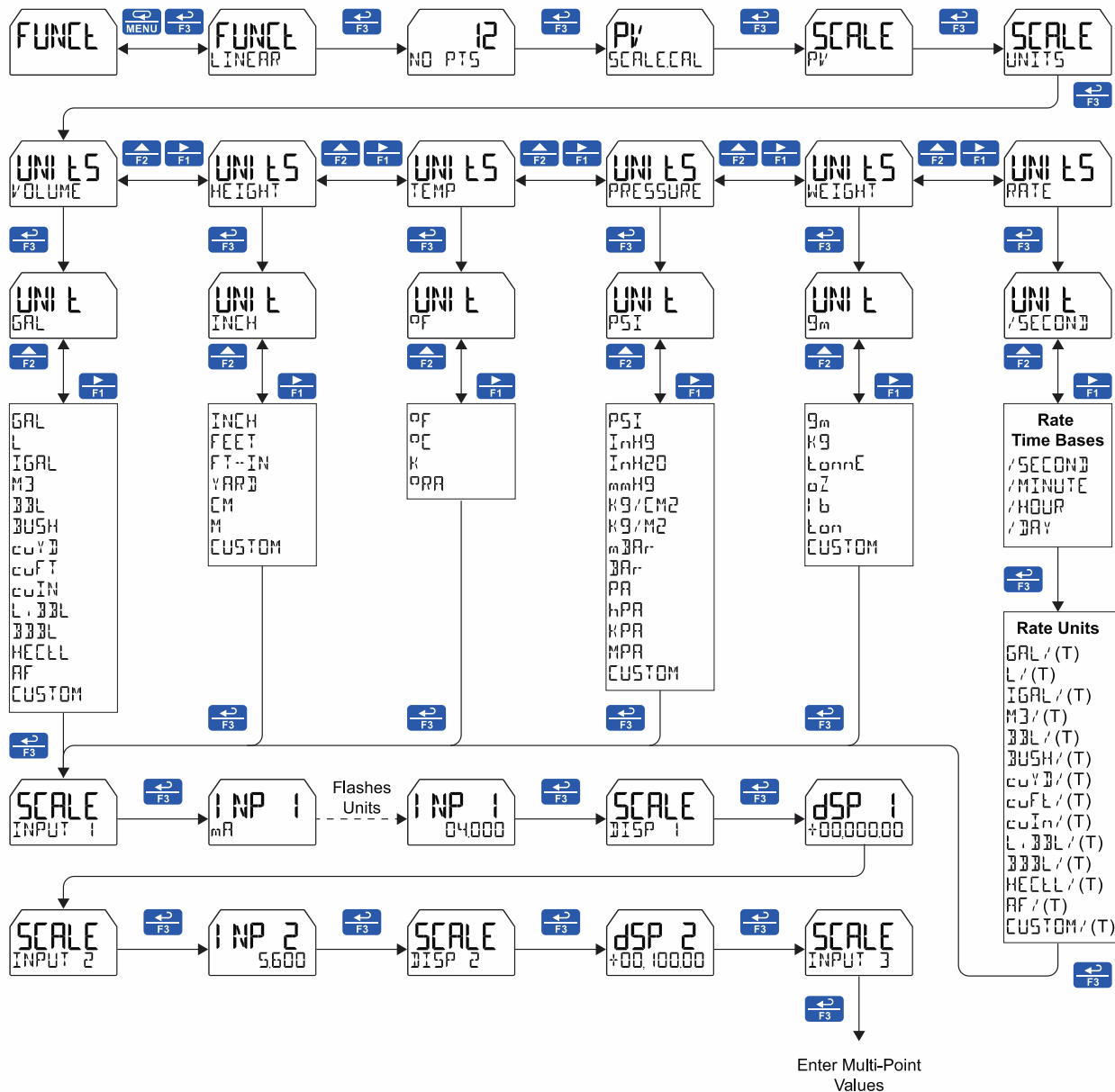

**Round Horizontal Tank Linearization (RH TANK)**

This function automatically calculates the volume in a round horizontal tank with flat ends. It is only available for PV2 while the meter is in dual-scale mode.

Set the display for the desired decimal point and engineering units before entering the round horizontal tank function. Select units (inches or cm) for the tank dimensions. Enter the diameter and the length in inches or cm and the results will be calculated automatically in US gallons or liters. The unit of measure for the volume can be changed using the display menu. See *Changing the Engineering Units (UNITS)* on page 36 and *Available Unit Classes and Units* on page 35 for a list of available volume units. There is no need to enter scaling values.

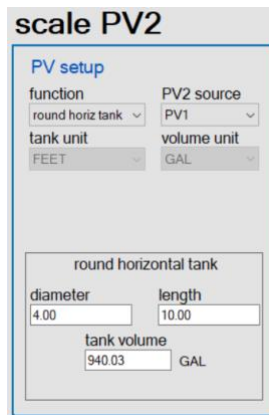
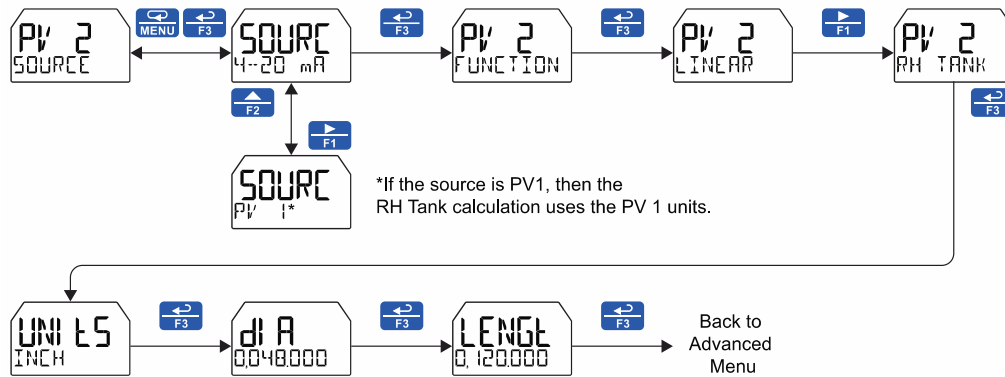

**MeterView XL Round Horizontal Tank Function Automatically Calculates the Volume Once the Diameter and the Length of the Tank are Entered.**

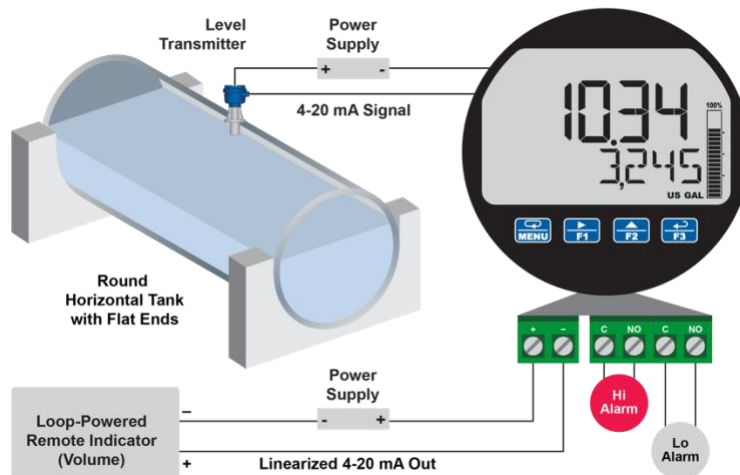

**PD6908 Displaying Height in Feet and Volume in Gallons in a Round Horizontal Tank Using the Round Horizontal Tank Linearization Feature.**

## Advanced Scaling and Calibration (SCALECAL)

This menu offers options to scale or calibrate the meter.

### Scaling the Input (SCALE)

The scale menu in the *Advanced* menu is the same as the scale menu in the *Input* menu. See *Scaling the 4-20 mA Input (INPUT)* on page 34 for details about scaling the meter.

### Calibrating the Input (CAL)

To scale the meter without a signal source, refer to *Scaling the 4-20 mA Input (INPUT)* on page 34.

The meter can be calibrated to display the process in engineering units by applying the appropriate input signal and following the calibration procedure. The **CAL** menu can be used either with a calibrated current source or with a live signal coming from a 4-20 mA transmitter connected to the process being measured.

During calibration, the mA input value will be displayed as **INP 1** and **INP 2**. Adjust the input source until the desired mA value is shown.

The use of a calibrated signal source is required.

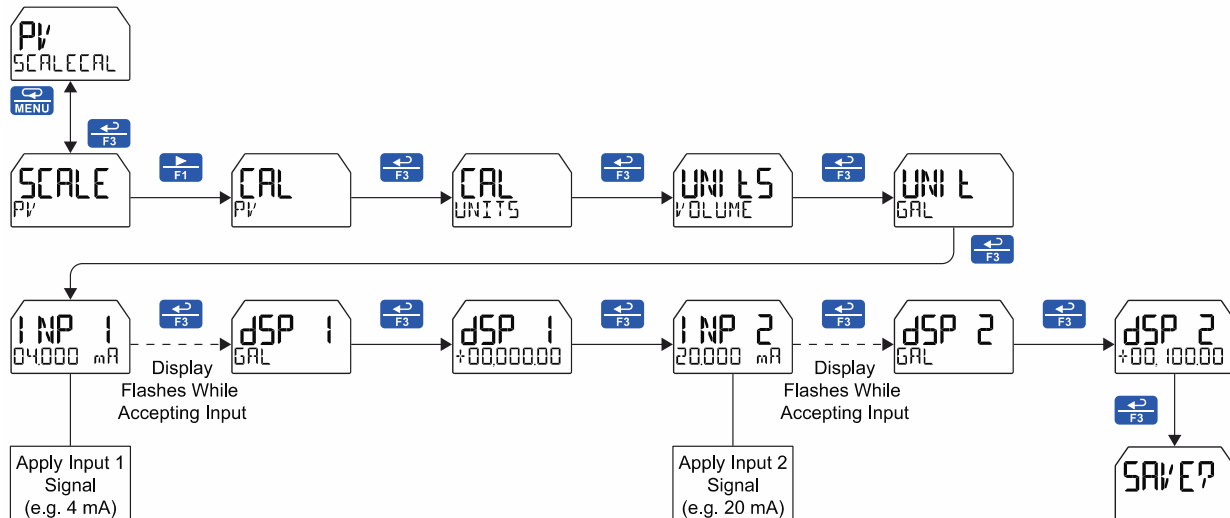

Follow these steps to calibrate the input:

1. After accessing the **SCALECAL** menu, press the **Right-Arrow** button to scroll to the *Calibration* menu (**CAL PV**) and press **Enter**.
2. Select the appropriate units for the desired process variable, then press **Enter**. For information on units, see *Available Unit Classes and Units* on page 35.
3. The meter displays **INP 1**. Apply a known signal and press **Enter**. The display will flash while accepting the signal.
4. After the signal is accepted, the meter displays **DSP 1**. Enter a corresponding display value for the input signal, and press **Enter** to accept.
5. The meter displays **INP 2**. Apply a known signal and press **Enter**. The display will flash while accepting the signal.
6. After the signal is accepted, the meter displays **DSP 2**. Enter a corresponding display value for the input signal and press **Enter** to accept.
7. After completing calibration, the **SAVE?** display will need to be acknowledged using the **Enter** key before calibration will take effect.

**Note:** The **SAVE?** prompt is not displayed if no changes have been made to the scaling.

### Low-Flow Cutoff (CUTOFF)

The low-flow cutoff feature allows the meter to be programmed so that the often-unsteady output from a differential pressure transmitter at low flow rates always displays zero on the meter. The cutoff value may be programmed from 0.1 to 99999. The meter will display zero below the cutoff value. The cutoff can be disabled to display negative values.

### Noise Filter (FILTER)

The noise filter is available for unusually noisy signals that cause an unstable process variable display. The noise filter averages the input signal over a certain period of time. The filter level determines the length of time over which the signal is averaged. The filter level can be set between 1 and 16 seconds or turned off. The higher the filter level, the longer the averaging time and so the longer it takes the display to settle to its final value. Setting the filter level to off disables the filter function.

### Noise Filter Bypass (BYPAS)

The noise filter bypass changes the behavior of the meter so that small variations in the signal are filtered out but large abrupt changes in the input signal are displayed immediately. The bypass value determines the minimum amount of signal change to be displayed immediately. All signal changes smaller than the bypass value are filtered or averaged by the meter. The noise filter bypass may be set between 0.1 and 99.9% of full scale.

### Enabling Password Protection (PASSWR)

The *Password* menu is used for programming security to prevent unauthorized changes to the programmed parameter settings.

To set a password, enter the *Password* menu and program a five-digit password. When a password has been enabled, the lock icon  will display in the upper-left side of the display. For instructions on how to program numeric values see *Setting Numeric Values* on page 33.

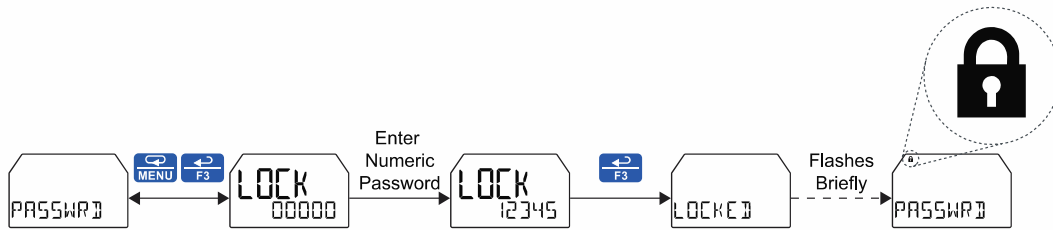

### Making Changes to a Password Protected Meter

If the meter is password protected, the meter will display the message `LOCKED` when the *Menu* button is pressed. Press the *Enter* button while the message is being displayed and enter the correct password to gain access to the menu. After exiting *Programming Mode*, the meter returns to its password protected condition.

### Disabling Password Protection

To disable password protection, access the *Password* menu and clear the entered password either by pressing and holding the *Right Arrow* button until all digits reset to zero or manually changing all the digits to zero. When the *Enter* button is pressed, the meter will display `UNLOCK` and will no longer require a password to access *Programming Mode*.

**Note:** If the meter is password protected and the password has been forgotten, the password may be overridden using the master password: **50865**



### Function Keys & Digital Input Available Settings

Refer to the following table for descriptions of each available function key or digital input setting.

Display	Description
DISP FN	Set the function key or digital input to display a value
DISPLAY	Cycle max, min, and PV(s)
DISP PV	Display the PV
PCT PV	Display the PV's percentage of max (20 mA)
UNITS	Display the PV's units
TAG	Display the PV's tag
DISPMIN	Display the PV's minimum
DISPMAX	Display the PV's maximum
MIN MAX	Display the PV's minimum and maximum value
mA IN	Display the mA input value
mAOUT	Display the mA output value
MENU FN	Set the function key or digital input to access a menu
RLY INFO	Go to relay information menu (INFO)
MANCTRL	Go to output control menu (CONTROL)
TMR OC 1	Open collector 1 timer
TMR OC 2	Open collector 2 timer
TMR R 1	Relay 1 timer
TMR R 2	Relay 2 timer
TIMERFN	Set the function key or digital input to start or stop a timer
STARTALL	Start all timers
STOPALL	Stop all timers
SSTPALL	Start or stop all timers
OC 1	Start/stop open collector 1 timer
OC 2	Start/stop open collector 2 timer
RLY 1	Start/stop relay 1 timer
RLY 2	Start/stop relay 2 timer
START	Start the selected timer output
STOP	Stop the selected timer output
STR--STP	Start or stop the selected timer output
ALARMFN	Set the function key or digital input to acknowledge an alarm
ACK	Acknowledge all active alarms
SETPPOINT	Set all output set point
SETPTOC 1	Set open collector 1 set point
SETPTOC 2	Set open collector 2 set point
SETPTR 1	Set relay 1 set point
SETPTR 2	Set relay 2 set point
SWATCHFN	Set the function key or digital input to activate stopwatch

Display	Description
START	Start the stopwatch
STOP	Pause/Stop the stopwatch
STR--STP	Start or stop the stopwatch
TAREFN	Set the function key or digital input to tare the display value
TARE	Tare the display value
RST TARE	Reset the display value
HOLD FN	Set the function key or digital input to hold an output
HOLDOUT	Hold all outputs
HL UNHLD	Hold or un-hold all outputs
OC 1-2	Hold/un-hold open collector outputs
RLY 1-2	Hold/un-hold relay outputs
mAOUT	Hold/un-hold 4-20 mA output
HOLD	Hold selected output
HL UNHLD	Hold or un-hold selected output
DISABLE	Disable the function key or digital input
RST FN	Set the function key or digital input to reset a value
RESET	Reset min, max, or max/min PV value
R MINMAX	Reset max and min PV value

### Enabling the Function Key Hint Feature (HINT)

Enabling the function key hint feature will cause a hint message to be displayed when pressing the F1, F2, or F3 function keys. This text gives a brief description of what the button is programmed to do. Pressing that function key a second time will execute that action.

The hint feature does not affect the digital input (DI) which is intended for immediate execution.

### Tare (TARE)

The tare function zero's out the display. In the case of scale weight, tare is used to eliminate container weight and provide net weight readings. There are two tare functions; Tare and Reset Tare. When the tare function is used, the display reading is offset by the displayed amount to make the displayed value zero. Reset tare removes the display offset of the net value, and the gross and net values become the same until a new capture tare is entered.

Program a function key or the digital input for the tare and reset tare.



### Changing System Settings (SYSTEM)

The System menu contains the following menus: *Analog Output Calibration, Restore Factory Defaults, Dual-Scale (PV2), Backlight, CapTouch Buttons Operation Mode, Information, and Internal Calibration.*

**Note:** The Analog Output Calibration menu is available only if the option is installed.

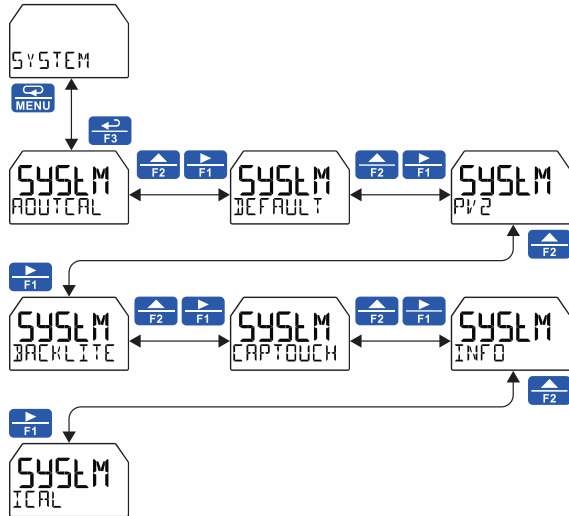

### Analog Output Calibration (ADUTCAL)

To perform the analog output calibration, it is recommended to use a milliamp meter with a resolution of at least 0.1  $\mu$ A to measure the output current. The values saved internally during this procedure are used for scaling the 4-20 mA output in the *Setup* menu.

#### 4-20 mA Output Calibration Procedure

1. Go to the *Advanced Features* menu and navigate to the SYSTEM menu and press Enter. Navigate to ADUTCAL and press Enter.
2. The display will show 4 mA. The ProtEX+ mA output should now be close to 4 mA. Enter the actual value read by the digital mA meter on the bottom display and press Enter.
3. The display will show 20 mA. The ProtEX+ mA output should now be close to 20 mA. Enter the actual value read by the digital mA meter on the bottom display and press Enter.
4. The ProtEX+ will now calculate the calibration factors and store them.
5. Press Menu to exit.

### Enabling the Dual-Scale Feature (PV2)

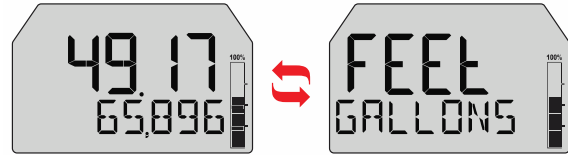

#### Dual-Scale Mode

**Top Display:** Toggling Between Process Variable and Units  
**Bottom Display:** Toggling Between Process Variable (in different scale) and Different Units

For some level applications, such as displaying the height and volume of a tank, a second PV can be enabled which can be scaled to display a different value based on the same 4-20 mA input. This is accomplished by enabling the dual-scale feature (PV2).

When the dual-scale feature is enabled, additional menus will be displayed to allow for the programming of the second PV. The input menu will display PV1 and PV2 for scaling and the display menu will allow both PVs to be displayed on either top or bottom display, for example. See *Display Functions & Messages* on page 28 for additional information on where additional dual-scale specific menus will appear.

PV2 must be enabled to use the Round Horizontal Tank feature. See *Round Horizontal Tank Linearization (RH TANK)* on page 58.

For instructions on how to enable PV2 see *Changing System Settings (SYSTEM)* on page 63.

### Enabling or Disabling the Backlight (BACKLITE)

The backlight may be enabled or disabled using the System - Backlight menu. The backlight is enabled by default, but the input must be wired appropriately for the backlight to function. See *Wiring Diagrams* on page 23.

### CapTouch Buttons Operation Mode (CAPTOUCH)

CapTouch buttons have two modes of operation: Normal and Delayed. Delayed mode prevents accidental trigger of the buttons. In the Delayed mode, the buttons enter into a low sensitivity state (sleep) and they ignore quick button presses after 20 seconds of inactivity. To wake up the buttons, press and hold any button for more than 2 seconds, the buttons respond normally.

### Viewing System Information (INFO)

System information, such as software (firmware) number and version, model number, and system tag, may be viewed in the INFO menu. Press the *Right Arrow* button to cycle through all available meter information. Press *Menu* to go back to the previous menu.

### Calibrating the Internal mA Reference (ICAL)

The meter is factory calibrated prior to shipment to display 0.00 to 100.00, which corresponds to the 4-20 mA input. The calibration equipment is traceable to NIST standards.

The use of calibrated signal sources is necessary to calibrate the internal source of the meter. The meter's internal source is what allows the user to scale the meter without applying a signal.

Check calibration of the meter at least every 12 months.

**Note:** Allow the meter to warm up for at least 15 minutes before performing the internal source calibration procedure.

The *Internal Calibration* menu is part of the *Advanced* menu. Internal Calibration is performed as follows:

1. Press the **Menu** button to enter *Programming Mode*.
2. Press the **Up-Arrow** button **twice** and press **Enter** to access the **Advanced** menu.
3. Press the **Up-Arrow** button and press **Enter** to access the **System** menu.
4. Press the **Up-Arrow** button and press **Enter** to access the **ICAL** menu.
5. The meter displays *low* input current message (4000 mA). Apply a 4 mA signal and press **Enter**. The display flashes for a moment while the meter is accepting the low input signal.
6. After the display stops flashing, the display moves to the *high* input calibration (20000 mA). Apply the high input signal and press **Enter**. The display will flash again while the meter is accepting the high input signal.

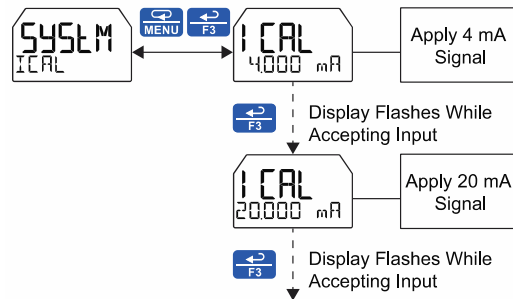



## Meter Operation

The meter is equipped with four CapTouch through-glass buttons. These buttons allow meter operation without removing the cover and exposing the electronics in a hazardous area.

Three CapTouch buttons labeled F1, F2, and F3 can be programmed as function keys to perform a variety of meter functions simply by pressing on the glass over the button. These include operation of the tare function, resetting the tare, resetting the meter's relays or open collectors, starting and stopping timers, and displaying max/min values. See *Function Keys & Digital Input Available Settings* on page 62 for a complete list of settings available.

A digital input is available on the meter and it may function in a similar fashion as the function keys to allow remote operation of a single task.





The max & min readings (peak & valley) reached by the process can be displayed either continuously by assigning it to a display line in the *Display* menu, or momentarily by pressing the F1 key (default) or assign it to any of the other function key or the digital input.

Pressing the F1 key cycles through various display values (e.g. max, min); press the Enter key to lock the display in the current process value and press the Enter key again to unlock the display.

The relay information menu shows runtime and cycle count for each relay.

Change the display units within the selected unit class at any time without the need to re-scale the meter. Select the desired units via the *UNITS* menu in the *DISPLAY* menu, and the meter automatically converts the display values to the new unit of measure.

## CapTouch Buttons Operation

Button	Description (Default Settings)
	Press to enter or exit <i>Programming Mode</i> , view settings, or exit max/min readings
	Press to display max/min readings.
	Press to reset max/min readings.
	Press to acknowledge all manually resettable relays or open collectors. Press to lock/unlock the display value after pressing the F1 key.

## CapTouch Buttons

The PD6908 is equipped with four capacitive sensors that operate as through-glass buttons so that it can be programmed and operated without removing the cover (and exposing the electronics) in a hazardous area.



These buttons can be disabled for security by selecting the Lock setting on the switch located on the side of the display module, close to the Menu button.

To actuate a button, press one finger to the glass directly over the marked button area. When the cover is removed, the CapTouch buttons can be used after the meter completes a self-calibrating routine (hand symbol flashes). The sensors are disabled when more than one button is pressed, and they will automatically re-enable after a few seconds (hand symbol off).

## CapTouch Button Tips & Troubleshooting

The CapTouch buttons are designed to work under any lighting condition and to protect against false triggering. If the CapTouch buttons are not needed during operation, they can be disabled (slide switch to Lock).

- To remove cover with power applied (safe area only), or to clean the window, place your hand over the buttons; this will temporarily disable the CapTouch buttons to prevent inadvertent use.
- Keep the glass window clean.
- Tighten the cover securely.
- Use a password to prevent tampering.

### ▲ IMPORTANT

- CapTouch buttons will not work if two or more buttons are detected as being pressed simultaneously. Be careful to avoid triggering multiple buttons or reaching across one button location to press another.

## Function Keys Operation

During operation, the programmable function keys operate according to the way they have been programmed in the *Advanced Features – User* menu. The table under *CapTouch Buttons Operation* on page 65 shows the factory default settings for F1, F2, and F3.

A hint message may be enabled to provide a description of what each function key does prior to executing their assigned function. See *Enabling the Function Key Hint Feature (HINT)* on page 62.

## Digital Input Operation

A digital input is standard on the meter. This digital input is programmed identically to function keys F1, F2, and F3. The input is triggered with a contact closure between DI+ and DI-, or with an active low signal. During operation, the digital input operates according to the way it has been programmed in the *Advanced Features – User* menu.

## Maximum/Minimum Readings

The max & min readings (peak & valley) reached by the process can be displayed either continuously or momentarily.

Display momentarily by pressing the F1 function key (default) or assigning to any of the other function keys or to the digital input in the *User* menu.

Display continuously by pressing the **Enter** button while the max/min is being displayed to lock the display. Press **Enter** again to unlock.

Any of the F1-F3 function keys (buttons) and the digital input can be programmed to reset the max & min readings. The meters are set at the factory to display the max reading by pressing the *Right Arrow/F1* button and to use the *Up-Arrow/F2* button to access the *Reset* menu. Press the *Right Arrow* button to cycle through the available parameters to reset.

**Top Display:** Process Value  
**Bottom Display:** Max & Min

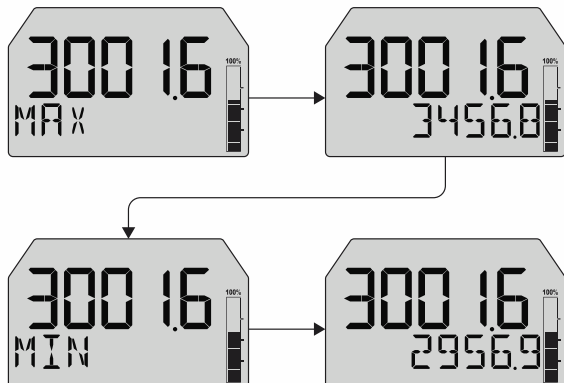

## Runtime & Cycle Count (INFO)

The relay information menu shows runtime and cycle count for each relay. These values may be cleared at any time by selecting the *Clear* option (CLEAR?). If the cycle count or runtime values need to be changed on a frequent basis, it would be convenient to set up a CapTouch button or the digital input to simplify this process.

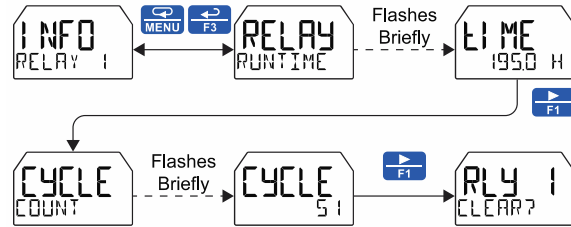

**Note:** See the menu tree under *Solid-State Relay Outputs (RELAY)* on page 45 for complete menu structure on this feature.

Meter displaying the amount of time a relay has been activated

Meter displaying the number of times a relay has cycled



## Changing Engineering Units

During operation of the meter, it is possible to change the display units within the selected unit class without the need to re-scale the meter. The **UNITS** menu in the **DISPLAY** menu allows the unit of measure to be changed (e.g. from gallons/second (GAL / S) to liters/second (L / S)) and the meter will automatically convert the display values to the new unit of measure. If entering a custom unit (CUSTOM), a custom conversion factor will need to be entered. See *Changing the Engineering Units (UNITS)* on page 36.

## Troubleshooting

This product is a highly sophisticated instrument with an extensive list of features and capabilities. If the CapTouch buttons are used to program the meter, it can be a difficult task to keep everything straight. That is why we strongly recommend the use of the free [MeterView XL](#) software for all programming activities. A cable is provided to use the MeterView XL software for programming the meter.

If you have programmed the meter with the CapTouch buttons and it is not working as intended, try re-programming the meter using the MeterView XL software.

## Reset Meter to Factory Defaults

When the parameters have been changed in a way that is difficult to determine what's happening, it might be better to start the setup process from the factory defaults. This can be accomplished using MeterView XL software or with the CapTouch buttons.

To load factory defaults:

1. Press the **Menu** button to enter *Programming Mode*.
2. Press the **Right-Arrow** button **twice** and press **Enter** to access the **Advanced** menu.
3. Press the **Up-Arrow** button and press **Enter** to access the **System** menu.
4. Press the **Right-Arrow** button and press **Enter** to access the **Default** menu.
5. Press **Enter** twice in quick succession. The meter will load default settings and restart.

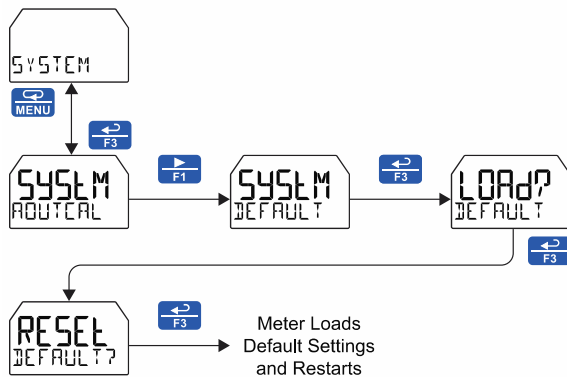

## Determining Software Version

To determine the software (firmware) version of a meter:

1. Press the **Menu** button to enter *Programming Mode*.
2. Press the **Up-Arrow** button **twice** and press **Enter** to access the **Advanced** menu.
3. Press the **Up-Arrow** button and press **Enter** to access the **System** menu.
4. Press the **Up-Arrow** button **twice** and press **Enter** to access the **Info** menu.
5. Press the **Right-Arrow** button to cycle through the meter information. When done, press the **Menu** button to return to the previous menu or press & hold **Menu** to exit to Run mode.

### Factory Default Settings

The following table shows the factory setting for most of the programmable parameters on the meter.

Parameter	Display	Default Setting
<b>Input Menu</b>		
Unit Class	UNITS	Volume
Unit of Measure	UNIT	Gallons
Input 1	INP 1	4.000 mA
Display 1	DSP 1	0.00
Input 2	INP 2	20.000 mA
Display 2	DSP 2	100.00
<b>Output Menu</b>		
Open Collector Output 1	OUTPUT 1	Disabled
Pulse Factor	FACTOR	1.0
Test Frequency	FREQ	100
Alarm	ALARM	PV
Alarm Action	ACTION	AUTO
Set Point	SET	20.00
Reset Point	RESET	10.00
Alarm On Delay	DELAY ON	0 seconds
Alarm Off Delay	DELAY OFF	0 seconds
Alarm Fail-safe	FAILSAFE	OFF
Red LED	RED	ON
Flash PV	FLASH	ON
Alarm Message	MSG	ON
Message Text	MSG EDIT	ALARM 1
Timer Off Delay	OFF_DELAY	1 minute
Timer On Time	ON_TIME	1 second
Timer Mode	MODE	Continuous
Open Collector Output 2	OUTPUT 2	Disabled
Set Point	SET	40.00
Reset Point	RESET	30.00
Message Text	MSG EDIT	ALARM 2
Relay Output 1	RELAY 1	Disabled
Alarm	ALARM	PV
Alarm Action	ACTION	AUTO
Set Point	SET	70.00
Reset Point	RESET	60.00
Alarm On Delay	DELAY ON	0 seconds
Alarm Off Delay	DELAY OFF	0 seconds
Alarm Fail-safe	FAILSAFE	OFF
Red LED	RED	ON
Flash PV	FLASH	ON
Alarm Message	MSG	ON
Message Text	MSG EDIT	ALARM 3

Parameter	Display	Default Setting
<b>Pump Control Menu</b>		
Pump Ctrl On	ON	70.00
Pump Ctrl Off	OFF	60.00
Pump Ctrl On Delay	DELAY ON	0 seconds
Pump Ctrl Off Delay	DELAY OFF	0 seconds
Pump Alt On 1	ON 1	70.00
Pump Alt Off 1	OFF 1	60.00
Pump Alt On 2	ON 2	90.00
Pump Alt Off 2	OFF 2	80.00
Pump Alt On Delay 1	DELAY 1 ON	0 seconds
Pump Alt Off Delay 1	DELAY 1 OFF	0 seconds
Pump Alt On Delay 2	DELAY 2 ON	0 seconds
Pump Alt Off Delay 2	DELAY 2 OFF	0 seconds
Timer Off Delay	OFF_DELAY	1 minute
Timer On Time	ON_TIME	1 second
Timer Mode	MODE	Continuous
Relay Output 2	RELAY 2	Disabled
4-20 mA Output	4-20 mA	PV
<b>Advanced Menu</b>		
Signal Conditioning Function	FUNCTN	Linear (2 pts)
Low Cutoff	CUTOFF	Enabled: 0
Filter	FILTER	2.0 seconds
Filter Bypass	BYPASS	0.4 PCT
Password	PASSWORD	00000 (Unlocked)
Function Key 1	F1	Display
Function Key 2	F2	Reset
Function Key 3	F3	Acknowledge
Digital Input	DI	Acknowledge
Hint Feature	HINT	Disabled
Dual-Scale	PV 2	Disabled
Backlight	BACKLITE	Enabled
CapTouch	CAPTUCH	Normal
<b>Display Menu</b>		
Unit of Measure	UNITS	Gallons
Decimal Point Location	DECPNT	2
Comma	COMMA	Enabled
Top Display	TOP	PV
Bottom Display	BOTTOM	Units

## Troubleshooting Tips

Certain sequences of events can cause unexpected results. To solve these issues, it is best to start fresh from factory defaults and use the manual as a step by step programming guide, rather than a random approach to programming. To reset the meter to factory defaults, see *Factory Default Settings* on page 68. In addition, for best results, we recommend using the free [MeterView XL](#) software for all programming needs.

Symptom	Check/Action
No display at all	Check: <ol style="list-style-type: none"> <li>The 4-20 mA current loop is providing at least 3.5 mA to the meter.</li> <li>The voltage drop of all devices connected to the 4-20 mA current loop does not exceed the max rating of the loop power supply.</li> </ol>
Not able to change setup or programming, <b>LOCK</b> is displayed	Meter is password-protected. Enter correct five-digit password to unlock or Master Password of 50865.
Meter display flashes: <ol style="list-style-type: none"> <li>□□□□</li> <li>..□□□□</li> </ol>	Check that the number of digits required for the scaled value does not exceed the maximum digits for the display. If it does, try adjusting the decimal point location for less precision or changing the PV display to the bottom display.
Display is unstable	Check: <ol style="list-style-type: none"> <li>Input signal stability and value.</li> <li>Display scaling vs. input signal.</li> <li>Filter and bypass values (increase).</li> </ol>
Display response is too slow	Check filter and bypass values
Display reading is not accurate	Check: <ol style="list-style-type: none"> <li>Input signal conditioner selected: Linear, square root, etc.</li> <li>Scaling or calibration</li> </ol>
Display does not respond to input changes, reading a fixed number	Check display assignment. It might be displaying max, min, or set point.
Display shows: <ol style="list-style-type: none"> <li>MAX and a number</li> <li>MIN and a number</li> </ol>	Press Menu to exit max/min display readings.
Relay operation is reversed	Check fail-safe settings in <i>Output</i> menu
Relays do not respond to signal	Check: <ol style="list-style-type: none"> <li>Relay action in <i>Output</i> menu</li> <li>Set and reset points</li> <li>Check manual control menu</li> </ol>
If the display locks up or the meter does not respond at all	Cycle the power to reboot the microprocessor.
CapTouch buttons do not respond	<ol style="list-style-type: none"> <li>If hand-symbol is flashing, multiple buttons were touch at the same time, wait a few seconds until the hand symbol goes off.</li> <li>If <i>Delayed</i> mode has been set, press &amp; hold any button for 5 seconds, the buttons should respond normally.</li> <li>If the slide switch on the display module is in the Lock position, move the switch to the Unlock position; see <i>Disabling the CapTouch Buttons</i> on page 25.</li> </ol>
Other symptoms not described above	Call Technical Support for assistance.



# Complete Product Line of Loop-Powered Meters

## WITH ALL THE SAME FEATURES & FUNCTIONALITY



2 Open Collector  
Outputs



2 Solid-State  
Relays



4-20 mA  
Output



Two-Color  
Backlight



Dual-Line  
Displays



Pump  
Control



Batch  
Control



Ex CE IECEx

### LARGE DISPLAY

#### PD4 Loop Leader+ Series

- NEMA 4X, IP65 Rated Wall-Mount Enclosures
- Large 5-Digit, 2.5" High Top Display
- Safe Area and I.S. Models
- ATEX and IECEx Certified



SF Ex CE IECEx

### EXPLOSION-PROOF

#### PD6900 ProtEX+ Series

- NEMA 4X, IP68 Rated Aluminum and Stainless Steel Enclosures
- CapTouch Through-Glass Buttons
- Explosion-Proof & I.S.
- CSA, ATEX, and IECEx Certified



UL LISTED Ex CE IECEx

### 1/8 DIN PANEL MOUNT

#### PD6600 Loop Leader Series

- NEMA 4X, IP65 Rated Front 1/8 DIN Panel Mount Meters
- General Purpose and I.S. and N.I. Models
- UL, C-UL, and CE Approved

VantageView+ CE

### FIELD-MOUNT

#### PD6900 VantageView+ Series

- NEMA 4X, IP66 Rated Plastic Enclosure
- CapTouch Through-Window Buttons
- General Purpose



MeterView XL Software Programs All These Products

Go to [PREDIG.COM](http://PREDIG.COM) for details

## Contact Precision Digital

### Technical Support

Call: (800) 610-5239 or (508) 655-7300

Fax: (508) 655-8990

Email: [support@predig.com](mailto:support@predig.com)

### Sales Support

Call: (800) 343-1001 or (508) 655-7300

Fax: (508) 655-8990

Email: [sales@predig.com](mailto:sales@predig.com)

### Place Orders

Email: [orders@predig.com](mailto:orders@predig.com)

For the latest version of this manual please visit

[www.predig.com](http://www.predig.com)

### PRECISION DIGITAL CORPORATION

233 South Street • Hopkinton MA 01748 USA

Tel (800) 343-1001 • Fax (508) 655-8990

[www.predig.com](http://www.predig.com)

