

DESCRIPTION

The MS3724 is a slim, plug-in high-level signal conditioner that converts DC current or voltage signals into commonly used DC signals and provides an isolated single output. This model features an allowable load resistance of 200Ω at 10V.

ORDERING CODE

MS3724 - -

Model _____

Power Supply _____

A: 100 to 240V AC (50 to 60Hz)
D: 24V DC
P: 100 to 240V DC

Input _____

A: 4 to 20mA DC	3: 0 to 1V DC
B: 2 to 10mA DC	4: 0 to 10V DC
C: 1 to 5mA DC	5: 0 to 5V DC
D: 0 to 20mA DC	6: 1 to 5V DC
E: 4 to 20mA DC *1	4W: ±10V DC
H: 10 to 50mA DC	5W: ±5V DC
Z: Other DC current signal	0: Other DC voltage signal

*1: Shunt resistor 50Ω

Output _____

3: 0 to 1V DC
4: 0 to 10V DC
5: 0 to 5V DC
6: 1 to 5V DC
3W: ±1V DC
4W: ±10V DC
5W: ±5V DC
0: Other DC voltage signal

Options _____

No code: None
/K: Fast response (0 to 90% response time: 10ms max.)
/X: Others (Special order)
 * For non-standard options, ask MTT for availability.

ORDERING INFORMATION

To place an order, please use the ordering code format as shown above.
 (e.g.) MS3724-A-4W4W

Other Ordering Examples:
 For an input code of "Z": MS3724-A-Z4 (Input: 8 to 20mA)
 For an output code of "0": MS3724-D-50 (Output: 2 to 5V)
 For an option code of "X": MS3724-A-44/X (Fc: 30Hz-3dB)
 Note: If you wish to include multiple options in your order, specify the option codes in series (e.g. /KX).

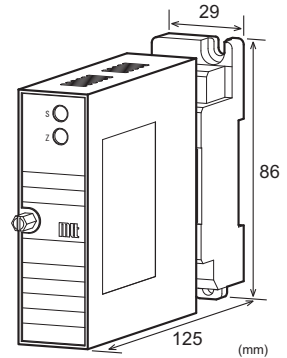
SPECIFICATIONS
POWER SECTION

Power Requirements	100 to 240V AC: 85 to 264V AC (47 to 63Hz) 24V DC: 24V DC±10%
Power Sensitivity	Better than ±0.1% of span for each power supply range.
Power Line Fuse	160mA fuse is installed (standard).
Power Consumption	
Power	100-240V AC 24V DC 100-240V DC
	7.5VA max 2.5W max 3.5W max

INPUT SECTION

Input Resistance		
Voltage Input (DC)	With or without power: 1MΩ min.	
Current Input (DC)	4 to 20mA (std.)	250Ω
	2 to 10mA	250Ω
	1 to 5 mA	100Ω
	0 to 20mA	250Ω
	10 to 50mA	10Ω
Allowable Input Voltage		
Voltage Input Model	30V DC max., continuous. (Standard for a span up to 10V)	
Current Input Model	40mA DC max., continuous. (Standard for 4 to 20mA)	
Ranges Available	Current Signal	Voltage Signal
Input Range (DC)	-100 to 100mA	-300 to 300V
Input Span (DC)	100μA *1 to 200mA	200mV *2 to 600V
Input Bias	-100 to 100%	-100 to 100%
Note: For any input range including negative input signals, the input spans for current and voltage signals range from (*1)200μA to 200mA and (*2)400mV to 600V, respectively.		
Input Spec. Ex.1: For 3 to 8V input, the input span is 5V and the bias +60%.		
Input Spec. Ex. 2: For -5 to 0V input, the input span is 5V and the bias -100%.		

● OUTPUT SECTION

Allowable Output Load	1V	20Ω min.
	5V	100Ω min.
	10V	200Ω min.
Allowable Lead Wire Resistance		
2-wire	Up to 1.25% of output load resistance	
4-wire	Up to 5% of output load resistance	
Note: If the wire resistance exceeds 0.05% (2-wire) or 0.2% (4-wire) of the output load resistance, zero/span adjustments are required.		
Zero Adjustment	Approx. ±5% of span. (Adjustable by the front-accessible trimmer.)	
Span Adjustment	Approx. ±5% of span. (Adjustable by the front-accessible trimmer.)	
Ranges Available		
Output Range (DC)	-10 to 10V	
Output Span (DC)	1 to 20V*	
Output Bias	-100 to 100%	
Note: For any output range including negative output signals, the output span ranges from *2 to 20V.		
Output Spec. Ex. 1: For 2 to 10V output, the output span is 8V and the bias +25%.		
Output Spec. Ex. 2: For -1 to 4V output, the output span is 5V and the bias -20%.		

● PERFORMANCE

Accuracy Rating	Better than ±0.1% of span (at 25°C±5°C).	
Temperature Effect	Better than ±0.2% of span per 10°C change in ambient.	
Response Time	85ms max. (0 to 90%) with a step input at 100%.	
CMRR	100dB min. (500V AC, 50/60Hz)	
Isolation	4-way isolation between input, output, power, and ground.	
Insulation Resistance	100MΩ min. (@ 500V DC) between input, output, power, and ground.	
Dielectric Strength	Input / Output / [Power, Ground]: 2000V AC for 1 minute (Cutoff current: 0.5mA) Power / Ground: 2000V AC for 1 minute (Cutoff current: 5.0mA)	
Surge Withstand Capability	Tested as per ANSI/IEEE C37.90.1-1989.	
Operating Environment	Ambient temperature: -5 to 55°C Humidity: 5 to 90% RH (non-condensing)	
Storage Temperature	-10 to 60°C	

● PHYSICAL

Installation	Wall/DIN rail mounting
Wiring	M3.5 screw terminal connection (with a power terminal block cover & drop-out prevention screws)
Screwing Torque	0.8 to 1.0 [Nm] * Recommended
External Dimensions	W29 × H86 × D125mm (including the mounting screw and socket)
Weight	Main unit: 130g max. Sockets: 80g max. Bracket: 2g max. each (2 pieces supplied per unit)

● MATERIALS

Housing	ABS resin (UL 94V-0)
Terminal Block	PBT resin (UL 94V-0)
Terminal Block Cover	PC resin (UL 94V-2)
DIN Rail Stopper	PP resin (UL 94HB)
Screw Terminal	Nickel-plated steel
Contacts Material and Finish	Brass with 0.2μm gold plating
Printed Circuit Board	Glass fabric epoxy resin (FR-4: UL 94V-0)
Anti-Humidity Coating	HumiSeal® 1A27NS (Polyurethane)

* HumiSeal® is a registered trademark of Chase Corporation.

TERMINAL ASSIGNMENT

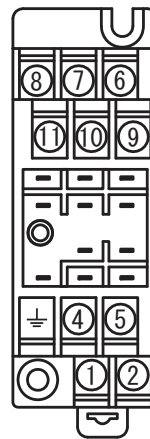

①	P (+)	POWER
②	N (-)	
⊥	GND	
④	+ OUTPUT	
⑤	+ SNES	
⑥	N.C.	
⑦	- OUTPUT	
⑧	- SENS	
⑨	+ INPUT	
⑩	- INPUT	
⑪	N.C.	

BLOCK DIAGRAM

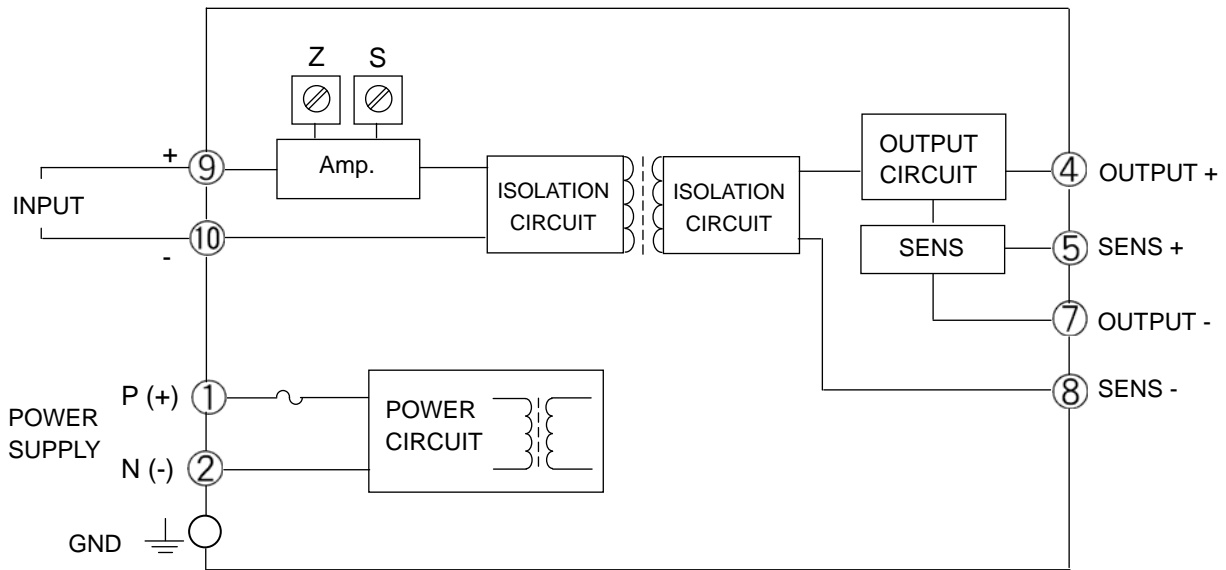

Normally, the terminals + OUTPUT and + SENS (#4 and #5) should be short connected with the supplied bracket. Also, the terminals - OUTPUT and - SENS (#7 and #8) should be short connected with the supplied bracket.

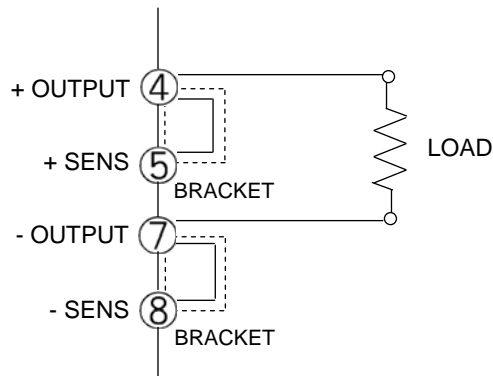

If the wiring resistance for output is too high to be acceptable, the terminal connections should be made without the supplied brackets as illustrated below.

