

## WARRANTY

### Gems Warranty

Gems warrants to the original purchaser of its products that such products will be free from defects in material and workmanship under normal use and service for a period which is equal to the shorter of one year from the date of purchase of such products or two years from the date of manufacture of such products.

This warranty covers only those components of the products which are non-moving and not subject to normal wear. Moreover, products which are modified or altered, and electrical cables which are cut to length during installation are not covered by this warranty.

Gems' obligation under this warranty is solely and exclusively limited to the repair or replacement, at Gems' option, of the products (or components thereof) which Gems' examination proves to its satisfaction to be defective. Gems SHALL HAVE NO OBLIGATION FOR CONSEQUENTIAL DAMAGES TO PERSONAL OR REAL PROPERTY, OR FOR INJURY TO ANY PERSON.

This warranty does not apply to products which have been subject to improper use, accident, negligence, abuse or misuse. Abuse shall be assumed when indicated by electrical damage to relays, reed switches or other components. The warranty does not apply to products which are damaged during shipment back to Gems' factory or designated service center or are returned without the original casing on the products. Moreover, this warranty becomes immediately null and void if anyone other than service personnel authorized by Gems attempts to repair the defective products. Equipment sold by Gems Sensors Inc. not intended for use in a nuclear installation, nor shall it be used as a "Basic Component" as same as defined under Part 21, Title 10 of the Code of Federal Regulations. In the event of such use, you agree to indemnify and hold us harmless from any and all subsequent liabilities and responsibilities which might arise in connection with such use.



## UCL-520 Two-Wire Ultrasonic Level Transmitter Owner's Manual

Part Number 225200



Version C  
© 2008 Gems Inc.  
All rights reserved.  
Manual # 226009

## Warranty, Service & Repair

### Return Policy

Returns are accepted on stock items up to 30 days from date of order.

You must contact our Returns Department for a Return Authorization (RA) number. Return the goods – freight prepaid – in the original container and include original packing slip. C. O. D. returns are not accepted. Gems reserves the right to apply restocking charges.

Gems further reserves the right to unilaterally waive this warranty and to dispose of any product returned to Gems where:

- a. There is evidence of a potentially hazardous material present with or on the product.
- b. The product has remained unclaimed at Gems for longer than 30 days after dutifully requesting disposition of the product from the Customer.

THERE ARE NO WARRANTIES WHICH EXTEND BEYOND THE DESCRIPTION ON THE FACE OF THIS WARRANTY. This warranty and the obligations and liabilities of Gems under it are exclusive and instead of, and the original purchaser hereby waives all other remedies, warranties, guarantees or liabilities, express or implied. EXCLUDED FROM THIS WARRANTY IS THE IMPLIED WARRANTY OF FITNESS OF THE PRODUCTS FOR A PARTICULAR PURPOSE OR USE AND THE IMPLIED WARRANTY OF MERCHANTABILITY OF THE PRODUCTS.

### Important Points:

- Gems products must be maintained and installed in strict accordance with the National Electrical Code and the applicable Gems product instruction Bulletin that covers installation, operation and proper maintenance. Failure to observe this information may result in serious injury or damages.
- The supply voltage to the sensor should not exceed 36 VDC, Max.
- Please adhere to the pressure and temperature limitations shown. These limitations must not be exceeded. These pressures and temperatures take into consideration possible system surge pressures/temperatures and their frequencies.
- Selection of materials for compatibility with the media is critical to the life and operation of Gems products. Take care in the proper selection of materials of construction, testing is required.
- Avoid over tightening when mounting.
- Life expectancy of switch contacts varies with application. Contact Gems if life cycle testing is required.
- Ambient temperature changes do affect switch set points, since the gravity of a liquid can vary with temperature.
- Our sensors have been designed to resist shock and vibration. However, shock and vibration should be minimized.
- Electrical entries and mounting points in an enclosed tank may require liquid/vapor sealing.
- Our sensors must not be field-repaired.
- Physical damage sustained by product may render it unserviceable.

This warranty may not be extended, altered or varied except by a written instrument signed by a duly-authorized officer of Gems, Inc.

# SPECIFICATIONS

## Step One

Range: 8" to 26.2' (20 cm to 8 m)  
 Accuracy: +/- 0.2% of span in air  
 Resolution: 0.039" (1 mm)  
 Beam width: 3" (7.6 cm) dia.  
 Dead band: 8" (20 cm)  
 Display type: LCD, 6-digit  
 Display units: Inch, cm or percentage  
 Display mode: Air gap or liquid height  
 Memory: Non-volatile  
 Supply voltage: 12- 28 VDC  
 Loop resist.: 500 Ohms @ 24 VDC  
 Signal output: 4 - 20 mA, two -wire  
 Signal invert: 4-20 mA, 20-4 mA  
 Calibration: Push button  
 Fail-safety: Selectable: 4 mA, 20 mA, 21 mA, 22 mA or hold last value  
 Process temp.: F: -4° to 140°  
 C: -20° to 60°  
 Temp comp.: Automatic  
 Electronics temp.: F: -40° to 160°  
 C: -40° to 71°  
 Pressure: 30 psi (2 bar) @ 25 °C., derated @  
 1.667 psi (113 bar) per °C, above 25 °C  
 Enclosure rating: NEMA 4X (IP65)  
 Enclosure vent: Water tight membrane  
 Encl. material: PC/ABS FR  
 Trans. material: PVDF  
 Process mount: 2" NPT (2" G)  
 Mount. gasket: Viton®  
 Conduit entrance: Dual, 1/2" NPT  
 Classification: General purpose  
 CE compliance: EN 61326 EMC

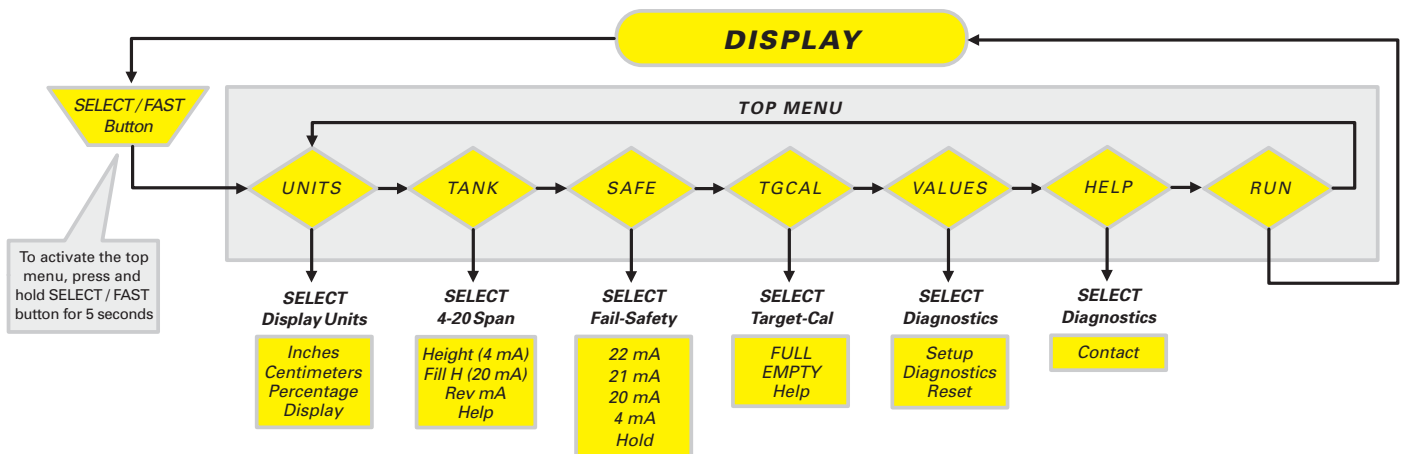
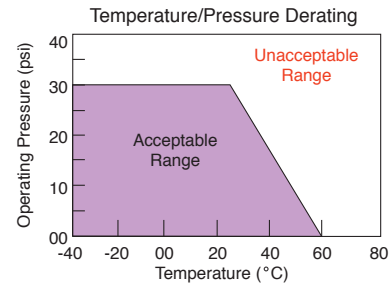
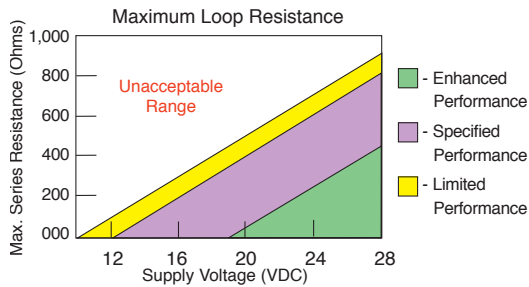
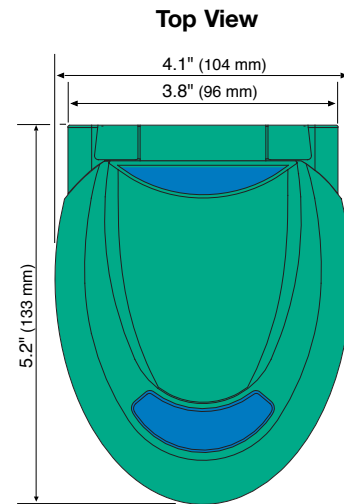
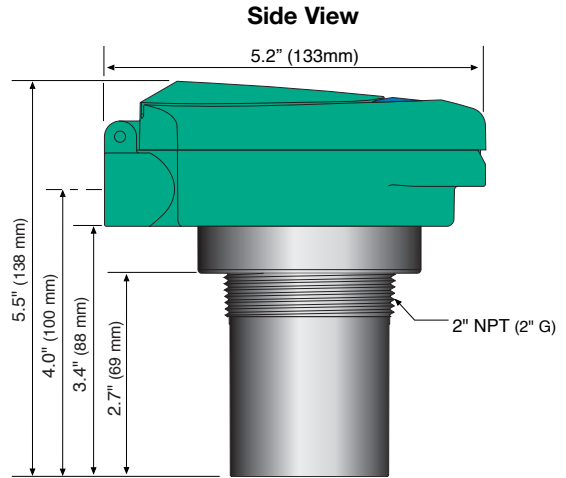

## SAFETY

### Step Two

**⚠ About this Manual:** PLEASE READ THE ENTIRE MANUAL PRIOR TO INSTALLING OR USING THIS PRODUCT. This manual includes information on the UCL-520 Ultrasonic Level Transmitter from Gems. Please refer to the part number located on the transmitter label to verify the exact model configuration which you have purchased.

**⚠ User's Responsibility for Safety:** Gems manufactures a broad range of level sensing technologies. While each of these sensors is designed to operate in a wide variety of applications, it is the user's responsibility to select a sensor model that is appropriate for the application, install it properly, perform tests of the installed system, and maintain all components. The failure to do so could result in property damage or serious injury.

**⚠ Proper Installation and Handling:** Only properly trained staff should install and/or repair this product. Install the transmitter with the Viton gasket and never overtighten the transmitter within the fitting. Always check for leaks prior to system start-up.

**⚠ Wiring and Electrical:** A supply voltage (loop power) of 12-28 VDC is used to power the UCL-520 transmitter. The sensor circuit should never exceed a maximum of 28 volts DC. Electrical wiring of the sensor should be performed in accordance with all applicable national, state, and local codes.

**⚠ Material Compatibility:** The UCL-520 transmitter enclosure is made of a flame retardant Polycarbonate (PC/ABS FR). The transducer is made of Polyvinylidene Fluoride (PVDF). Make sure that the model which you have selected is chemically compatible with the application media and its environment.

**⚠ Enclosure:** While the transmitter housing is liquid-resistant the UCL-520 transmitter is not designed to be operational when immersed. It should be mounted in such a way that the enclosure and transducer do not come into contact with the application media under normal operational conditions.

**⚠ Make a Fail-Safe System:** Design a fail-safe system that accommodates the possibility of transmitter and/or power failure. Gems recommends the use of redundant backup systems and alarms in addition to the primary system.

**⚠ Flammable, Explosive or Hazardous Applications:** Do not use the UCL-520 transmitter of general purpose transmitters within classified hazardous environments.



### Warning

Always use the Viton gasket when installing the UCL-520 transmitter in its fitting, and always connect the shield wire to the common ground.

## OVERVIEW

### Step Three

**A. Application:** The general-purpose ultrasonic transmitter provides non-contact level detection up to 26.2' or 8 m. The transmitter is well suited for a wide range of corrosive, waste and slurry type media, and is broadly selected for atmospheric bulk storage, day tank and waste sump applications.

**B. Part Number:** The part and serial numbers are located on the wrench flat. Check the part number on the product label and confirm which of the below model configurations you have purchased:

Part Number	Range	Supply	Mount
UCL-520	26.2' (8 m)	12-28 VDC	2" NPT

**C. NEMA 4X Enclosure:** The NEMA 4X (IP65) enclosure has a flip cover with two 1/2" NPT female conduit ports and an internal terminal strip for wiring. To open the enclosure, you will need a small screwdriver. Insert the tool into the hole located at the top edge of the enclosure and turn counter-clockwise. Rotate the hinged cover up for 135° access to the faceplate screen and terminal strip.

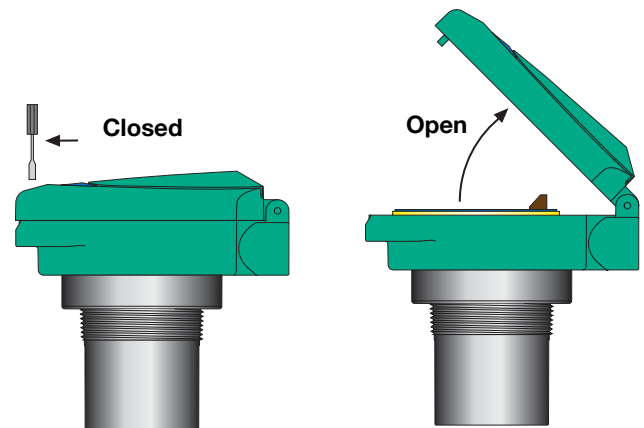

Before closing the enclosure, make sure that the enclosure gasket is properly seated, and that any conduit fittings, liquid tight cable connectors and/or plugs are properly installed and sealed.

### Handling Static-Sensitive Circuits/Devices



When handling the transmitter, the technician should follow these guidelines to reduce any possible electrostatic charge build-up on the technicians body and the electronic part.

1. Always touch a known good ground source before handling the part. This should be repeated while handling the part and more frequently after sitting down from a standing position, sliding across the seat or walking a distance.
2. Avoid touching electrical terminals of the part unless making connections.
3. DO NOT open the unit cover until it is time to calibrate.

## PREPARATION

### Step Four

**A. Supply Voltage:** The transmitter power supply voltage should never exceed a maximum of 28 VDC. Gems controllers and meters have built-in 24 VDC power supplies for use with the transmitter. Alternative controllers and/or power supplies with a minimum output of 12 VDC may also be used with the transmitter for calibration and/or operation.

**B. Cable Length:** The cable length between the transmitter and it's point of termination may be extended up to a maximum of 1000 feet, using a well-insulated, shielded wire from 14 to 18 gauge.

**C. Factory Span:** All transmitter models are factory calibrated with 4 mA at their maximum range (tank empty) and 20 mA at their minimum range (tank full). **For optimum measurement performance up to 26.2' or 8 m, the UCL-520 should be calibrated with 4 mA at it's minimum range (tank full) and 20 mA at it's maximum range (tank empty).** The 4 and 20 mA span set points can be reverse calibrated on all models.

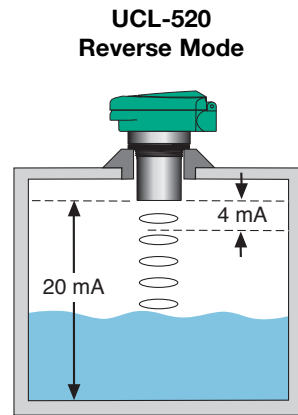

**D. Maximum Applied Range:** The Individual or cumulative effects of agitation, vapor or foam can reduce the overall quality of signal return and shorten the maximum applied range of the transmitter. To determine the maximum applied range of the transmitter in your application, refer to the below derating chart.

### Maximum Applied Range Derating Chart

#### UCL-520

Agitation	= 1-3 @ 50 kHz
Vapor	= 3-5 @ 50 kHz
Foam	= 4-6 @ 50 kHz

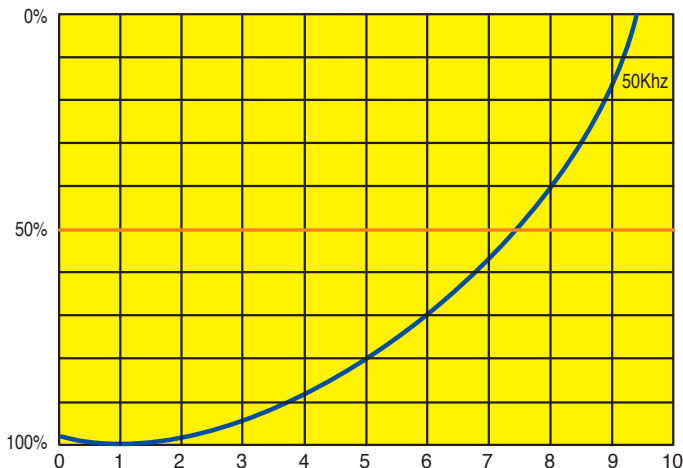

## MENU ITEMS

### Step Five

**A. WARMUP:** This is the initial power up mode. When this message is displayed, the transmitter is going through its power up routine, and validating the target value. After a short period of time, this message will disappear and be replaced by a numeric value.

**B. FULL:** Level has reached the programmed FULL set point.

**C. EMPTY:** Level has reached the programmed EMPTY set point.

**D. UNITS:** Selectable in Inches Centimeters or Percent. The factory default is Inches.

**E. INCHES:** Inch units of measurement.

**F. CM:** Centimeters units of measurement.

**G. PERCNT:** 0-100% units of measurement. Percent is the calculated value based on the 4mA and 20mA set points.

**H. DISPLAY:** Allows the user to select if the display will read in units of air or units of liquid. Factory default is units of air.

**H. TANK:** Menu through which the 4-20 mA span is adjusted.

**I. HEIGHT:** The point in inches or centimeters from the transducer face where the output will be 4 mA (generally the bottom of the tank). Factory default is the same as the unit's maximum range. Example: UCL-520 = 314" maximum range which is also the same 4 mA set point under factory default.

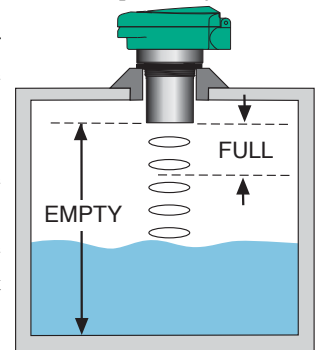

**J. Fill H (Fill Height):** The point in inches or centimeters from the bottom of the tank to the high level where the output will be 20 mA (generally the straight wall distance from the bottom of the tank). NOTE: The transmitter dead band is automatically subtracted from the FILL H. Example: UCL-520 = 8" dead band. Therefore the maximum FILL H is 306" [maximum range] - 8" [dead band] = 306".

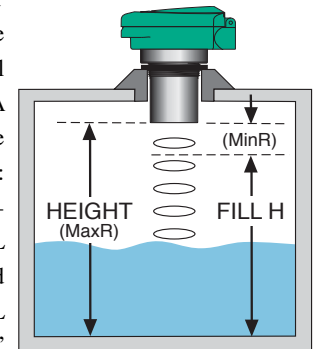

**K. REV mA (Reverse mA):** Allows the user to select 20 mA at the bottom and 4 mA at the top of the tank (20-4 mA). Factory default is 4 mA (MaxR) at the bottom and 20 mA (MinR) at the top.

**L. SAFE:** The FAIL-SAFE current output of the transmitter if the acoustic signal is LOST. Selectable at 4 mA, 20 mA, 21 mA, 22 mA or HOLD. (HOLD is the last 4-20 mA value prior to LOST).

**M. TG CAL:** Allows the user to use an unknown distance for setting of the 4 mA and 20 mA span.

## MENU ITEMS

### Step Six

**N. FULL:** Target calibration technique that allows the user to enter the present distance from the transducer face to the liquid or a reflective target as the 20 mA (FULL) set point

**O. EMPTY:** Target calibration technique that allows the user to enter the present distance from the transducer face to the liquid or a reflective target as the 4 mA (EMPTY) set point.

**P. WAIT:** Indicates that you have selected either FULL or EMPTY and the transmitter is calculating the distance value.

**Q. VALUES:** Allow the user to view the present calibration settings that are programmed in the transmitter.

**R. SETUP:** Displays the present calibration settings such as UNITS, MinR, MaxR, and SAFE.

**S. MINR:** The lesser distance from the transducer to the full tank height of liquid.

**T. MAXR:** The greater distance from the transducer to the empty tank height of liquid.

**U. RESET:** Allows the user to reset the transmitter to its original factory default settings.

**V. DIAG (Diagnostics):** Allows the user to view the present values of LEVEL, TEMP, ECHO, POWER, MOUNT and VER.

**W. LEVEL:** Displays the current Inch, Centimeter or Percent measured value.

**X. TEMP:** Displays the temperature in the vessel at the transducer.

**Y. ECHO:** Displays the present acoustic signal strength.

**Z. POWER:** Displays the present acoustic power level

**AA. MOUNT:** Displays either QUIET (no fitting noise) or NOISY (potential fitting noise), If NOISY with transmitter performance issues, please contact Gems to discuss your installation.

**BB. VER (VERSION):** Displays the transmitter software version.

**CC. DONE:** Indicates that the new value has been saved in memory (after depressing the SELECT/FAST key).

**DD. ERROR:** Indicates that the new value has NOT been saved in memory (after depressing the SELECT/FAST or EXIT key).

**EE. RUN:** When displayed, if the user depresses the SELECT/FAST key, the transmitter will exit the programming mode and return to the RUN mode for normal operation.

**FF. UP / DOWN:** Increases or decreases the SET 20 and SET 4 display values in the programming mode. NOTE: Simultaneously holding down the SELECT/FAST button while pressing the UP or DOWN button will increase the speed of the display.

## PROGRAMMING

### Step Seven

**A. Introduction:** The transmitter has two modes, RUN and PROGRAM. In the RUN mode, the transmitter is operational and the display will indicate the liquid height in inches, centimeters or percent.

In the PROGRAM mode, the display will indicate the selected mode of calibration. The transmitter arrives from the factory with its settings at 4 mA = maximum range and 20 mA = minimum range (defined by the dead band or minimum measurement distance). The transmitter is programmed with its built-in display and three button keyboard. **Under normal application circumstances, users typically program the HEIGHT distance value, FILL H distance value and FAIL-SAFE mode.**

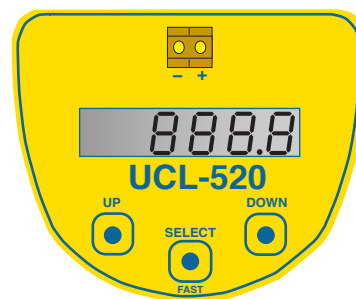

**B. Entering the Program Mode:** Press and hold the SELECT/FAST button for approximately 5 seconds until the display changes from a numeric to PROG, indicating that you have entered the PROG mode.

*Note: When PROG mode is active, the UCL-520 will hold the last current value. The value will not change until the transmitter is returned to RUN Mode.*

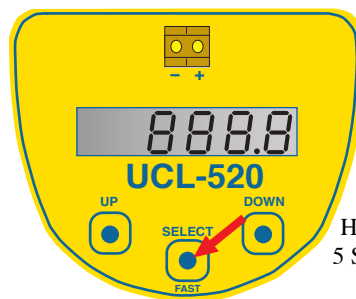

Hold for  
5 Seconds

After entering the PROG mode, the display will scroll through the top menu, alternately flashing UNITS, TANK, SAFE, TG CAL, VALUES, HELP and RUN.

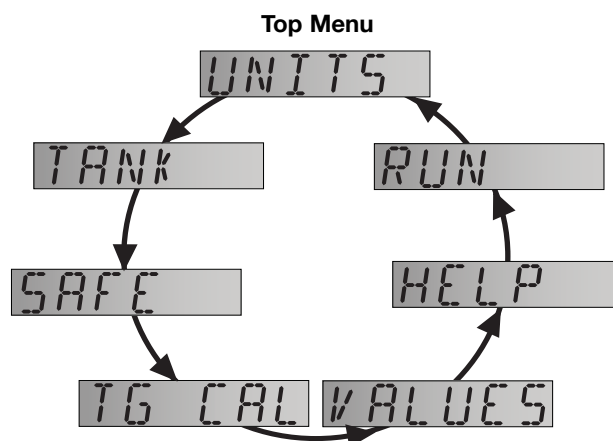

## PROGRAMMING

### Step Eight

**C. Programming UNITS:** To change UNITS from INCHES to CM or PERCENT.

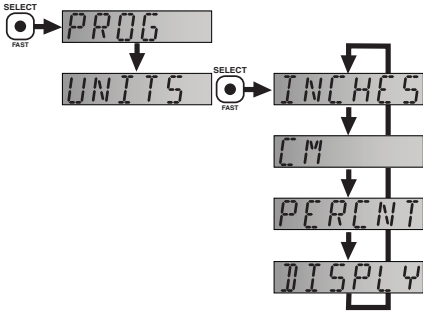

1. Press the SELECT/FAST button and hold it for 5 seconds until PROG appears.
2. When UNITS appears, press the SELECT/FAST button. The display will rotate between INCHES, CM, PERCENT and DISPLAY.
3. Press the SELECT/FAST button when the UNITS you want (INCHES, CM or PERCENT) appear. The display will then display SAVED.

You have successfully changed the UNITS function.

*Note: Percent units can only be selected after the transmitters Height (4 mA) and Fill H (20 mA) set points have been programmed. Therefore initial programming should always be done in INCH or CM UNITS.*

**D. Display Mode:** The transmitter is factory set such that the display reads the distance from the bottom of the transmitter to the liquid surface. This is also referred to as the Air distance (Air Mode). As the level of liquid increases, the display will decrease and vice versa. Conversely, the transmitter may be set to read the actual height of liquid in the tank (Liquid Mode). Below, a tank height of 100" will display 40.0, which represents 40.0" of air in the AIR Mode. In the Liquid Mode, the display will change to 60.0, which represents 60.0" of liquid.

#### AIR MODE



#### LIQUID MODE

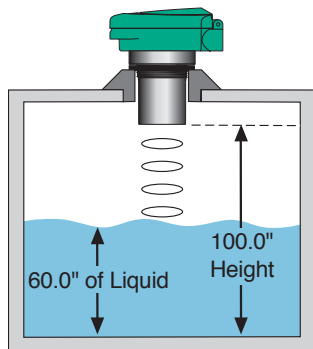
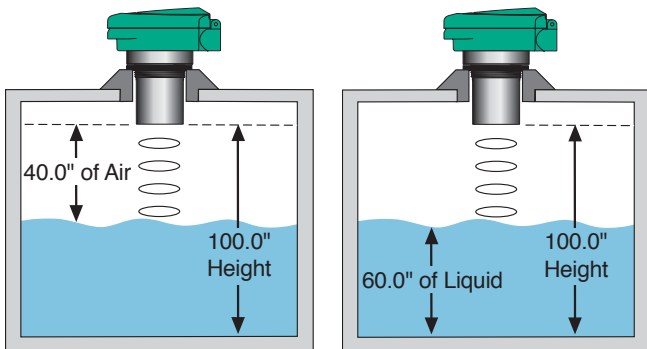

## PROGRAMMING

### Step Nine

**E. Change Display Mode:** To change the display to indicate the height of liquid, follow the instructions below:

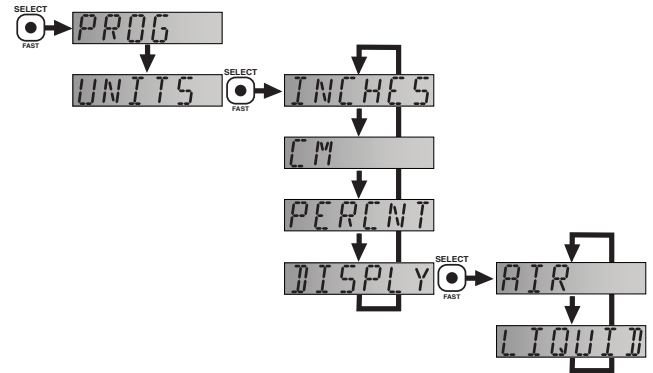

1. Press the SELECT/FAST button and hold it for 5 seconds until PROG appears.
2. When UNITS appears, press the SELECT/FAST button. The display will rotate between INCHES, CM, PERCENT and DISPLAY.
3. When DISPLAY appears, press the SELECT/FAST button. The display will rotate between AIR or LIQUID.
4. When LIQUID appears, press the SELECT/FAST button.

You have successfully programmed the LIQUID mode.

**F. Programming Off Tank:** If you know the dimensions of your tank, you may input the 4 mA and 20 mA set points manually without performing target calibration (requiring you to raise and lower the liquid level). To do so, review the following:

**HEIGHT:** The point in inches or centimeters from the transducer face where the output will be 4 mA (generally the bottom of the tank). Factory default is the same as the unit's maximum range. Example UCL-520 = 314" maximum range which is also the same 4 mA set point under factory default.

**FILL H:** The point in inches or centimeters from the bottom of the tank to the high level where the output will be 20 mA (generally the straight wall distance from the bottom of the tank). NOTE: The transmitter dead band is automatically subtracted from the FILL H. Example: UCL-520 = 8" dead band. Therefore the maximum FILL H is 314" [maximum range] - 8" [dead band] = 306".

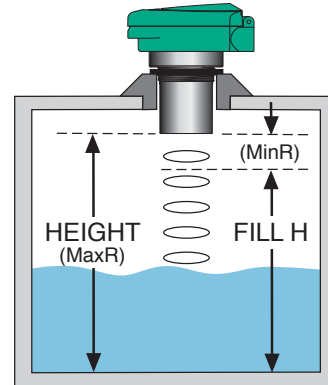

## PROGRAMMING

### Step Ten

**G. Programming HEIGHT:** To change HEIGHT 4 mA value.

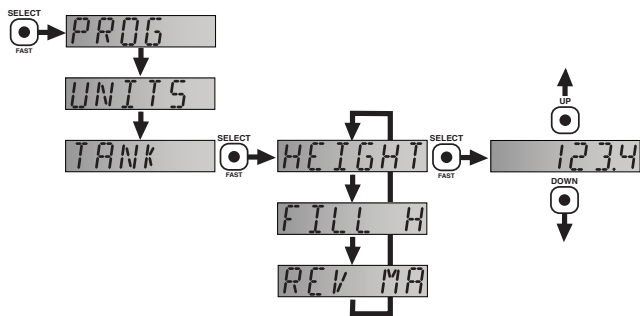

1. Press the SELECT/FAST button and hold it for 5 seconds until PROG appears.
2. When TANK appears, press the SELECT/FAST button. The display will rotate between HEIGHT, FILL H and REV mA.
3. When HEIGHT appears, press the SELECT/FAST button. The display will show a decimal reading in the selected UNITS.
4. Press the UP/DOWN buttons to increase or decrease this value to the distance from the transducer face to the bottom of the tank. NOTE: Simultaneously holding down the SELECT/FAST button while pressing the UP or DOWN button will increase the speed of the display.
5. When you have reached the desired value, press SELECT/FAST to SAVE.

**H. Programming FILL H:** To change FILL H 20 mA value.

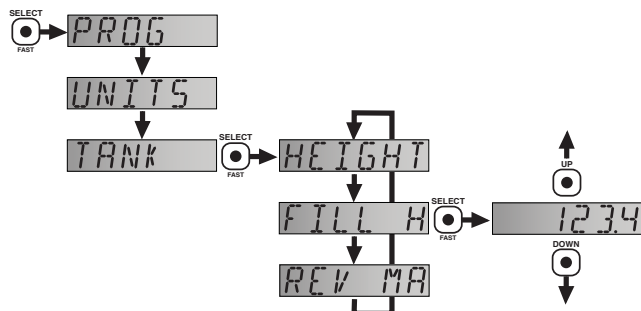

1. Press the SELECT/FAST button and hold it for 5 seconds until PROG appears.
2. When TANK appears, press the SELECT/FAST button. The display will rotate between HEIGHT, FILL H and REV mA.
3. When FILL H appears, press the SELECT/FAST button. The display will show a decimal reading in the selected UNITS.
4. Press the UP/DOWN buttons to increase or decrease this value to the distance from the bottom of the vessel to the full point (typically the straight wall height).
5. When you have reached the desired value, press SELECT/FAST to SAVE it.

You have successfully programmed the FILL H or 20mA value.

*NOTE: You can increase the speed at which the display changes by pressing the SELECT/FAST button while simultaneously holding down the UP or DOWN button.*

## PROGRAMMING

### Step Eleven

**I. Programming REV mA (Optional):** In factory default, the

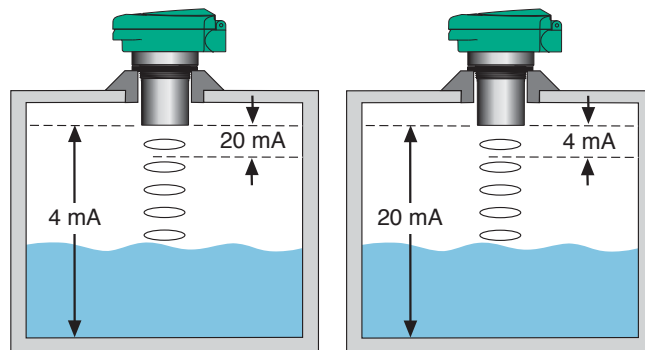

#### Normal mA Mode

MaxR (4 mA) set at empty tank and MinR (20 mA) set at full tank.

#### Reverse mA Mode

MaxR (20 mA) set at empty tank and MinR (4 mA) set at full tank.

transmitter operates with 4 mA at the maximum range (MaxR), and 20 mA at the dead band (MinR). Using the menu item REV mA, you can change the unit to reverse this to 20 mA at the furthest distance (MaxR) and 4 mA at the closest distance (MinR).

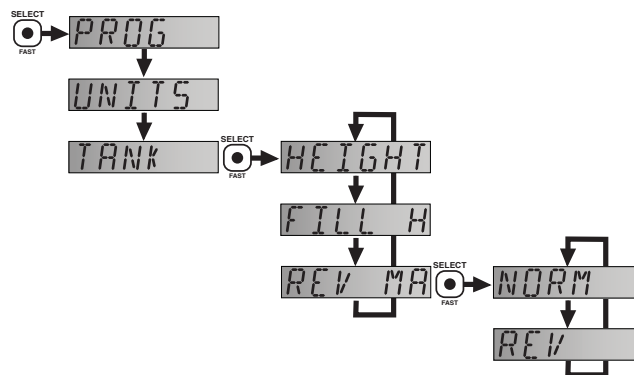

*NOTE: You must set HEIGHT and FULL R prior to reversing the 4 and 20 mA. Regardless of which mode you are in (Norm or Rev), changes to the HEIGHT or FULL R are always with respect to the original settings programmed.*

*NOTE: Any changes to the HEIGHT will effect the FULL R value. The FULL R will stay at the same physical level in the tank. An increase to the HEIGHT value will result in an equal increase to the FULL R value. A decrease to the HEIGHT value will result in an equal decrease to the FULL R value.*

## PROGRAMMING

### Step Twelve

**J. Programming SAFE Mode:** To change SAFE mode.

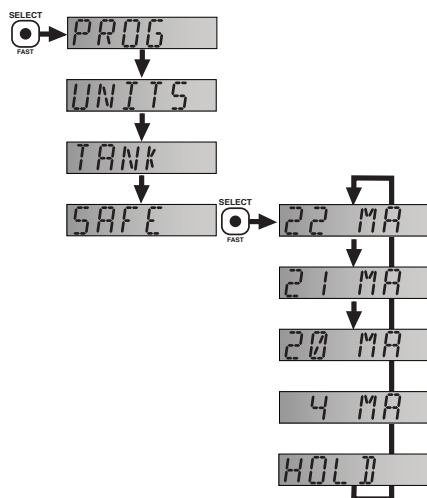

1. Press the SELECT/FAST button and hold it for 5 seconds until PROG appears.
2. When SAFE appears, press the SELECT/FAST button.
3. The display will now rotate through 22mA, 21mA, 20mA, 4mA and HOLD. When you reach the desired setting, press the SELECT/FAST button to SAVE it..

You have successfully programmed the SAFE mode.

**K. Programming Target Calibration (Optional):** The transmitter's 4 mA and 20 mA set points can be target calibrated ON the tank by raising and lowering the liquid level, or OFF the tank using the distance to a flat reflective target such as a wall. Generally, target calibration is done ON the tank. To do so, follow the EMPTY and FULL tank programming steps on the next page.

*NOTE: A transmitter installed on a tank operating in the factory default RUN mode will display the distance from the bottom of the sensor to the liquid surface. The value will decrease as the tank is filled or increase as the tank is emptied. Make sure that you do not overflow the tank or completely empty the tank while moving the liquid level to the desired high or low set point distance for target calibration.*

**TG CAL:** Allows the user to use an unknown distance for setting of the 4 mA and 20 mA span.

**FULL:** Target calibration technique that allows the user to enter the present distance from the transducer face to the liquid or a reflective target as the 20 mA (FULL) set point

**EMPTY:** Target calibration technique that allows the user to enter the present distance from the transducer face to the liquid or a reflective target as the 4 mA (EMPTY) set point.

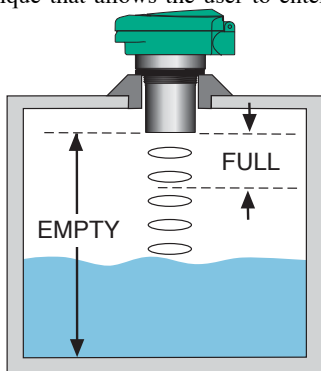

## PROGRAMMING

### Step Thirteen

**L. Programming TG CAL EMPTY Tank:** With the tank EMPTY or the liquid in a low level state, apply power to the transmitter. Begin programming after WARMUP.

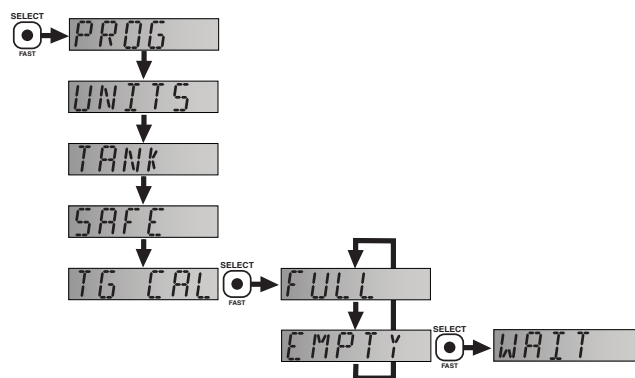

1. Press the SELECT/FAST button and hold it for 5 seconds until PROG appears.
2. When TG CAL appears, press the SELECT/FAST button. The display will rotate between FULL and EMPTY.
3. When EMPTY appears, press the SELECT/FAST button. WAIT will be displayed followed by SAVED.

You have successfully programmed the EMPTY or 4 mA value.

**M. Programming TG CAL FULL Tank:** With the tank FULL, or the liquid in a high level state, apply power to the transmitter. Begin programming after WARMUP.

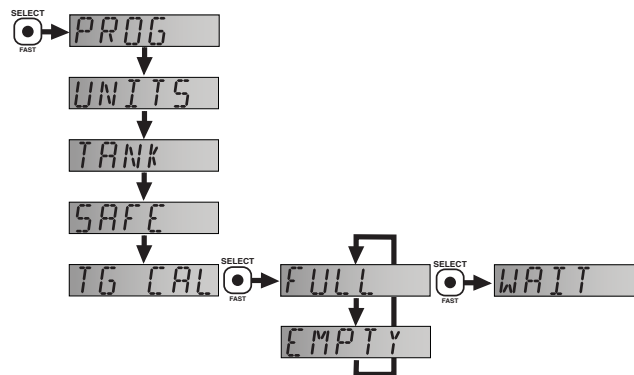

1. Press the SELECT/FAST button and hold it for 5 seconds until PROG appears.
2. When TGCAL appears, press the SELECT/FAST button. The display will rotate between FULL and EMPTY.
3. When FULL appears, press the SELECT/FAST button, WAIT will be displayed followed by SAVED.

You have successfully programmed the FULL or 20 mA value.

*Note: The display will now indicate LEVEL height in the RUN mode.*



# INSTALLATION

## Step Fourteen

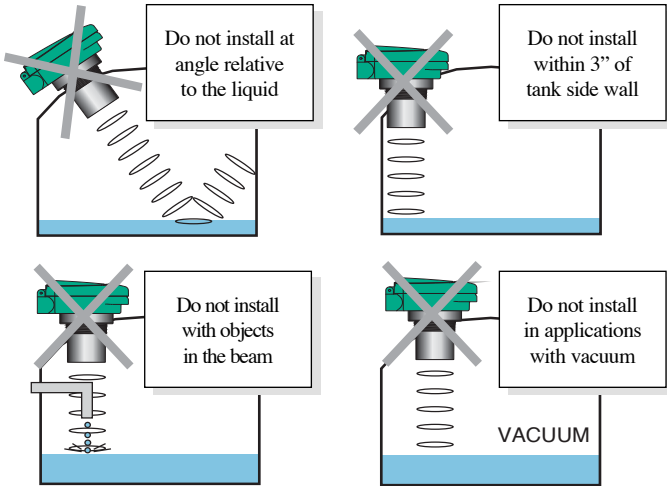

### Warning

Gems ultrasonic transmitters have been optimized for use in non-metallic fittings. Avoid the use of metal fittings.

Install the appropriate installation fitting. Make sure that the fitting and transmitter threads are not damaged or worn. Install the transmitter with the included Viton mounting gasket. Hand tighten the transmitter within the fitting. Perform an installed leak test under normal process conditions prior to system start up.

**A. Fitting Selection:** Check the transmitter part number to determine the required 2" fitting thread type. The transmitter is commonly installed in tank adapters, flanges, brackets or stand pipes.

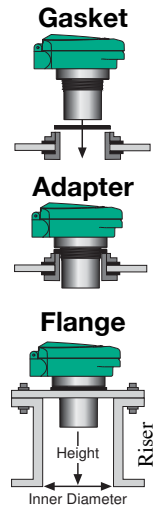

**1. Adapter:** Select a tank adapter fitting with minimal height so as to ensure that the installed transducer will not be substantially elevated into the fitting. Avoid tank adapter styles with threads and/or pipe stops forward of the installed transducer.

**2. Flange:** Tall flanges with narrow risers impede the acoustic signal. Select a fitting with the right riser height versus inner diameter geometry. The transmitter may be elevated up to 12" (30 cm) in a 6" (15 cm) riser, 8" (20 cm) in a 4" (10 cm) riser and 3" (7.6 cm) in a 2" (5 cm) riser.

**3. Stand Pipe:** A stand pipe may be used to dampen turbulence or separate surface foam. Select a minimum 3" pipe for the stand pipe.

The pipe length should run the measurement span. Cut a 45° notch at the bottom of the pipe and drill a 1/4" pressure equalization hole high in the dead band.

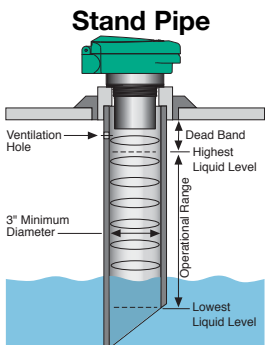

# WIRING

## Step Fifteen

### A. Wiring to a Typical Two-Wire Loop Powered Indicator

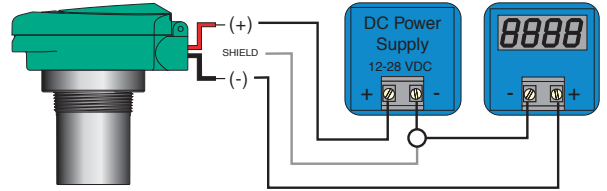

### B. Wiring to a Typical PLC

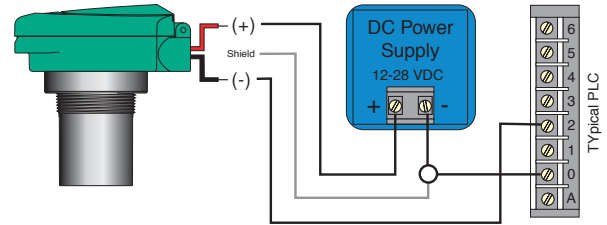

## TROUBLESHOOTING

### Step Sixteen

#### A. Viewing Programmed VALUES:

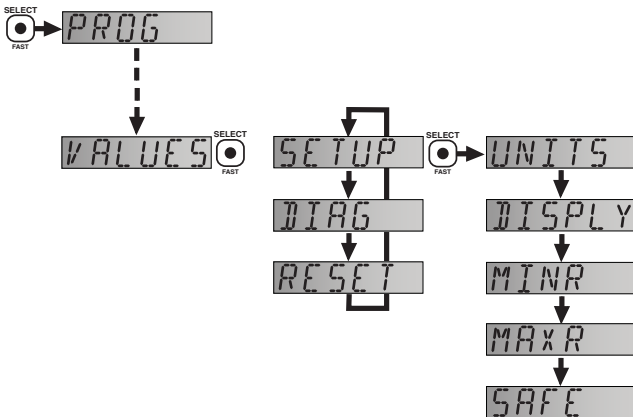

1. Press the SELECT/FAST button and hold it for 5 seconds until PROG appears.
2. When VALUES appears, press the SELECT/FAST button. The display will rotate between SETUP, DIAG and RESET.
3. When SETUP appears, press the SELECT/FAST button. You will now begin viewing calibration settings (UNITS, Display, MinR, MaxR and SAFE) that are programmed in the transmitter.

When complete the display will revert back to the VALUES menu.

#### B. Viewing DIAGNOSTICS:

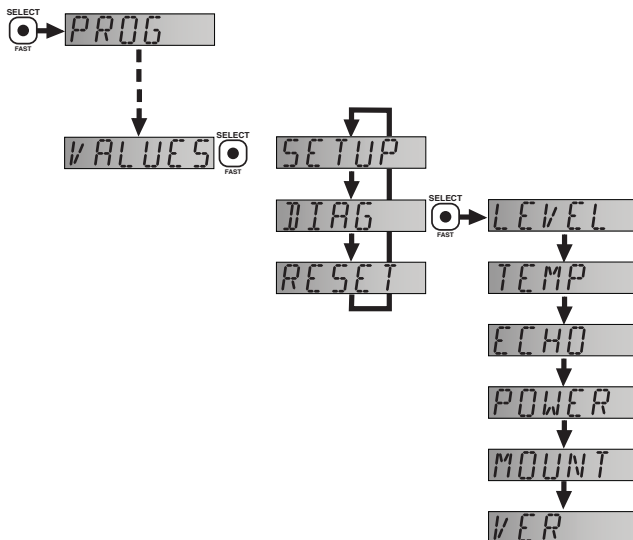

1. Press the SELECT/FAST button and hold it for 5 seconds until PROG appears.
2. When VALUES appears, press the SELECT/FAST button. The display will rotate between SETUP, DIAG and RESET.
3. When DIAG appears, press the SELECT/FAST button. You will now begin viewing diagnostic values (LEVEL, TEMP ECHO, POWER, MOUNT and VER) that may be relevant to the transmitter and it's performance in your application.

When complete the display will revert back to the VALUES menu.

## TROUBLESHOOTING

### Step Seventeen

#### C. Factory RESET:

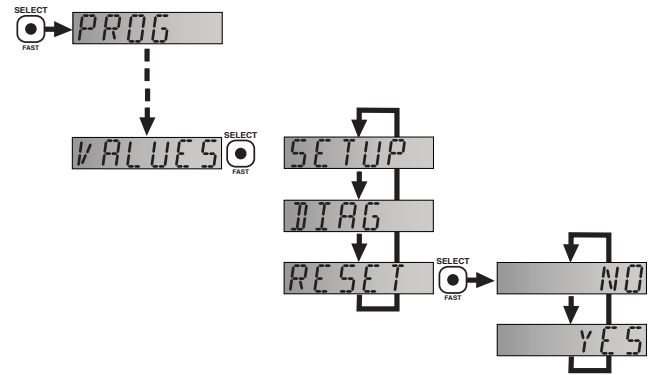

1. Press the SELECT/FAST button and hold it for 5 seconds until PROG appears.
2. When VALUES appears, press the SELECT/FAST button. The display will rotate between SETUP, DIAG and RESET.
3. When RESET appears, press the SELECT/FAST button. The display will rotate between YES or NO.
4. When YES appears, press the SELECT/FAST button.

Note: FACTORY RESET resets the transmitter back to its original factory default settings: (20 mA = Minimum Range, 4mA = Maximum Range and SAFE = 22mA).

#### D. Testing the Transmitter

Factory Set Points		
Transmitter	4 mA Setting	20 mA Setting
UCL-520	26.2' (8m)	8" (20 cm)

1. Connect a multi-meter in transmitter with the black wire to read the current output.
2. Verify that the current increases (tank filling) and decreases (tank emptying) appropriately in the calibrated span.

3. If not, carefully observe and attempt to correlate any installation, level or application event for more specific troubleshooting.

4. Write down the information in DIAGNOSTICS (LEVEL, TEMP ECHO, POWER, MOUNT and VER) and have it ready when you contact your Gems representative.

