



Warrick® Series 47

Intrinsically Safe Sensing Circuit

Installation and Operation Bulletin

Table of Contents

| | |
|---------------|---|
| Page 2 | Installation Instructions: Safe Sensing Circuits <ul style="list-style-type: none">- Mounting Location- Wiring: General Information- Grounding |
| Page 3 | Technical Information <ul style="list-style-type: none">- Specifications- Ordering Information |
| Page 4 | Control Diagram <ul style="list-style-type: none">- A.C. Supply- Grounding- System Fault Contacts |
| Page 5 | Operation Instructions <ul style="list-style-type: none">- Indicator Contacts- Test Terminals- Silence Terminals- Probe Connections- Auxiliary Contact Board |
| Page 6 | Operation Instructions |
| Page 7 | Operation Instructions <ul style="list-style-type: none">- Adjusting the Set Point Position- Adjusting the Set Point Position: SVP-2 Sensor Only- Troubleshooting Guide |
| Page 8 | Technical Information <ul style="list-style-type: none">- Module Replacement |

Installation: Intrinsically Safe Sensing Circuits

This bulletin should be used by experienced personnel as a guide to the installation of Series 47. Selection or installation of equipment should always be accompanied by competent technical assistance. We encourage you to contact Gems Sensors or its local representative if further information is required.

Important

Before proceeding to install and wire Series 47 controls, read and thoroughly understand these instructions.

When installed according to these instructions, this device provides intrinsically safe sensing circuits for interface into Class I, II and III, Division 1, Groups C, D, E, F and G. Electrical equipment connected to associated apparatus should not exceed maximum ratings marked on product.

*** Warning: To prevent ignition of flammable or combustible atmospheres, disconnect power before servicing.

Mounting Location

The control must be situated in a non-hazardous area where an explosive atmosphere will not exist at any time, unless it is mounted in a suitable U.L. approved explosion-proof enclosure with suitable U.L. approved explosion-proof seals.

Wiring: General Information

1. Intrinsically safe wiring must be kept separate from non-intrinsically safe wiring.
2. Intrinsically safe and non-intrinsically safe wiring may occupy the same enclosure or raceway if they are at least 2 inches (50mm) apart and separately tied down. Inside panels, field wiring terminals for intrinsically safe circuits must be separated by at least 2 inches (50 mm) from non-intrinsically safe terminals.
3. Wire the control device(s) to the Series 47 relay as shown in figure 1. A separate rigid metallic conduit should be used to enclose the conductors of the intrinsically safe control circuit.
4. An approved seal should be used at the point where the intrinsically safe control circuit wiring enters the hazardous area.

For intrinsically safe output wiring, use #14 or #16 AWG type MTW or THHN wire. By using these wire types in conjunction with the following distance recommendations, you will not exceed the maximum capacitance for field wiring. Use **Table 1** as a guide for maximum wire runs.

Table 1

| Model No. | Sensitivity | Distance Per Channel |
|------------------|--------------------|--|
| 47C1XXXX | 26 K | 2-Wire Sensor - 1,500 Ft. 3-Wire Sensor - 750 Ft. |
| 47D1XXXX | 50 K | 2-Wire Sensor - 900 Ft. 3-Wire Sensor - 450 Ft. |
| 47E1XXXX | 100 K | 2-Wire Sensor - 400 Ft. 3-Wire Sensor - 200 Ft. |

Grounding

The four mounting holes on the Series 47 provide an electrical connection for earth grounding between the control's internal solid state circuitry and the enclosure chassis. To insure proper grounding, use only metal screws and lock washers when mounting this control. Terminal G on the supply line/load side terminal strip is a redundant system ground terminal and must be connected to earth ground buss of the control's AC supply line feeder.

Notes

1. Intrinsically safe terminals can be connected to any non-energy generating or storing switch device such as a pushbutton, limit or float type switch or any Warrick electrode and fitting assembly.
2. To prevent electrical shock from supply line/load side powered connections, the Series 47 should be mounted in a tool accessible enclosure of proper NEMA rated integrity.
3. For U.L. 913 Listed panels, a metallic partition may be necessary to provide adequate spacing between non-intrinsically safe and intrinsically safe wiring and /or terminals.
4. For additional guidance on "Hazardous Location Installation" and "Intrinsically Safe Devices", consult ANSI/ISA standard RP 12-6 or NEC articles 500-516.

Technical Information

Specifications

Master Fault Contact for Indication of System Alarm: (Terminals 7,8 & 9)

Contact Design: SPDT (1 form C): one normally open (N.O.) and one normally closed (N.C.), non-powered contacts Contact Ratings for each channel.

Load Contact Ratings: 5A @ 120/240 VAC resistive and 30 VDC resistive, 1/10 Hp @ 120/240 VAC.

Indicator Contacts for Warnings, and Normal Lights: (Terminals C and 1-5)

Load Contact Ratings: 25mA @ 120 VAC

Indicator Contact for Bell: (Terminals C & 6)

Bell Contact Ratings: 5A @ 120/240 VAC and 30 VDC resistive, 1/10 Hp

Optional Auxiliary Contacts for Indication of Individual Channel Alarm:

Contact Design: SPDT (1 form C): one normally open (N.O.) and one normally closed (N.C.), non-powered contacts Contact Ratings for each channel

Load Contact Ratings: 5A @ 120/240 VAC resistive and 30 VDC resistive, 1/10 Hp @ 120/240 VAC.

Contact Life: Mechanical - 10 million operations. Electrical - 1,000,000 operations minimum at rated load.

Electronics Module: Solid state components epoxy encapsulated in a black nylon shell

Sensitivity: Models operate from 0-100,000 ohms maximum specific resistance

Temperature: -40° to 150° F Ambient.

Primary Voltage: 120 VAC models + 10% - 15%, 50/60 Hz.

Supply Current: Relays energized - 30mA @ 120 VAC

Secondary Circuit: 12 VAC RMS voltage on probes, 6ma current RMS.

Terminals: Standard Form C removable terminal strip containing a size 4 pan head screw with a clamping plate. Will accept up to one #14 AWG wires per terminal. Use copper (60°-77° C) wire only. Torque to 20 inch pounds.

Listings: U.L. Intrinsically Safe (UL 913)

Ordering Information

47 X 1 X XXX

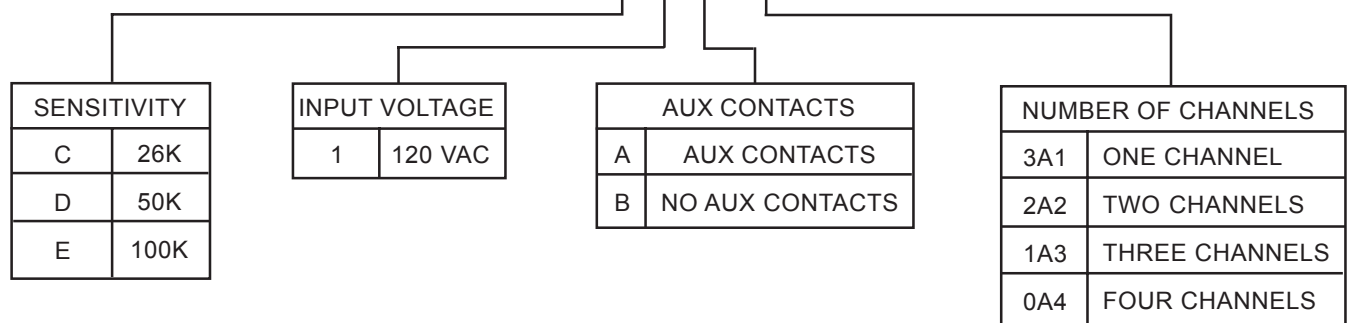

Control Diagram

Series 47 can be used with any non-energy generating or storing switch device such as a pushbutton, limit or float type switch or any Warrick electrode fitting assembly.

Figure 1

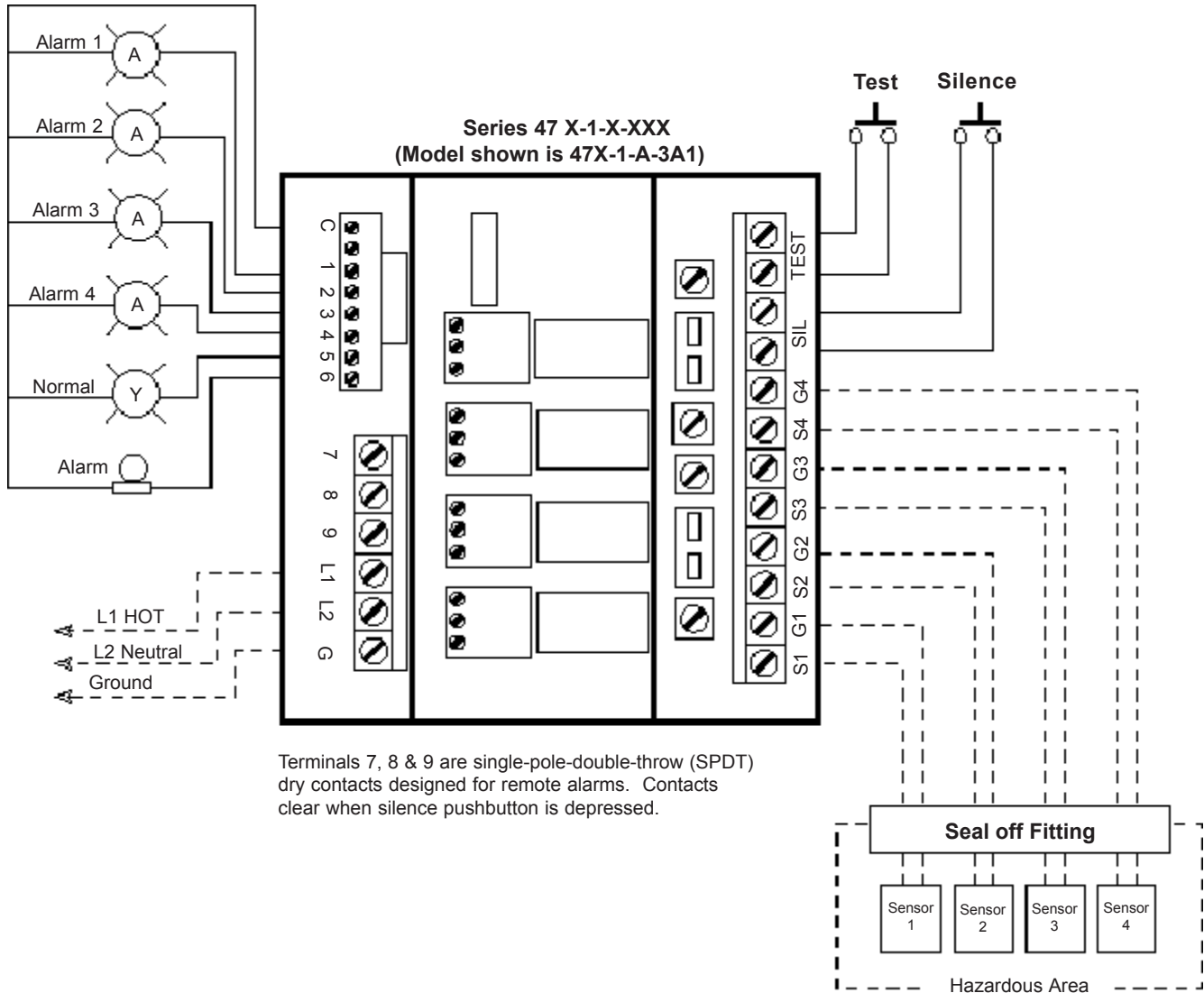

A. C. Supply

Connect the incoming supply HOT lead to the L1 terminal, NEUTRAL lead to the L2 terminal and EARTH GROUND lead to the "G" Terminal. Note: the incoming power supply should have the same electrical characteristics as indicated on the control's label.

Grounding

Terminal "G" on the supply line/load side terminal strip is a redundant system ground terminal and must be connected to the earth ground buss of the panel's AC supply line feeder.

System Fault Contacts: (Terminals 7,8 & 9)

- 7: Opens during a warning condition and remains open until the silence button is pushed or the warning condition is cleared.
- 8: Common contact to 7 and 9.
- 9: Closes during a warning condition and remains closed until the silence button is pushed or the warning condition is cleared.

Operation Instructions

Indicator Contacts: (Six powered contacts available for indication)

C: Common (neutral) for powered contacts (terminals 1-6)

- 1- Warning indicator for channel one
- 2- Warning indicator for channel two
- 3- Warning indicator for channel three
- 4- Warning indicator for channel four
- 5- Normal indicator for channels one through four
- 6- Master indicator bell for channels one through four.

Contact will close when a fault condition is present on any or all of the four channels. The contact will open when all four channels are in the normal mode. If the contact is closed (indicating an alarm) and the silence button is pushed, the contact will open and remain open until another warning occurs.

Note

**Warning indicators will remain activated until the fault condition is cleared.
Normal indicator will remain activated until a fault condition occurs.**

Test Terminals

The test feature allows the user to perform a check on the electronic circuitry. When a remote N.O. pushbutton is depressed, the circuitry on all four channels is tested. If all four channels are in the normal mode and the button is pressed, the four warning contacts and the bell contact will close until the button is released. When released, the normal contact will close- warning and bell contacts will open. A N.O. pushbutton switch must be used to activate the test function.

Silence Terminals

The silence feature is used to open the bell contact in the event of a warning on one or more of the channels. When a warning occurs, the bell contact will close and remain closed until either the warning condition clears or the silence button (N.O. remotely mounted) is pushed.

Probe Connections (S1, G1 through S4, G4)

Most sensors will require two (2) wires. Hook up the sensor that corresponds to the application and set the mode DIP switch. See figure 3 and table 2 for further information. For three (3) wire sensors (DSP-2 or combination DWP/DFP) CONTACT FACTORY. Non-used sensor connections must have DIP switches set in the inverse mode.

Auxiliary Contact Board (Optional)

These non-powered contacts are available for switching auxiliary loads. Each channel has its own auxiliary contact assigned to it. When a warning condition occurs, the corresponding auxiliary contact will energize. The N.O. contact will close and the N.C. contact will open. When the warning condition is cleared, the N.O. contact will open and the N.C. contact will close. These relays are not affected by the silence button. Wire loads as shown in figure 2.

Figure 2

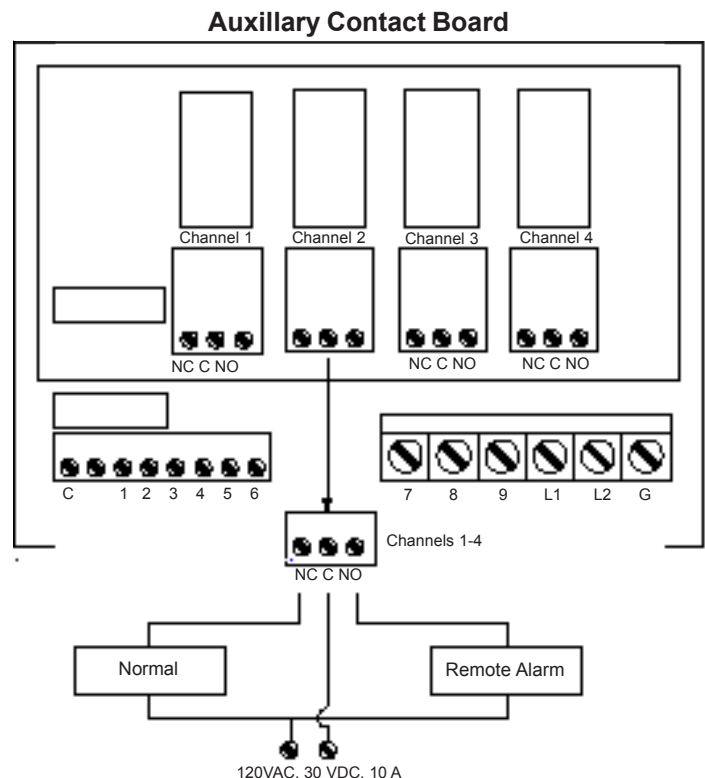

Operation Instructions

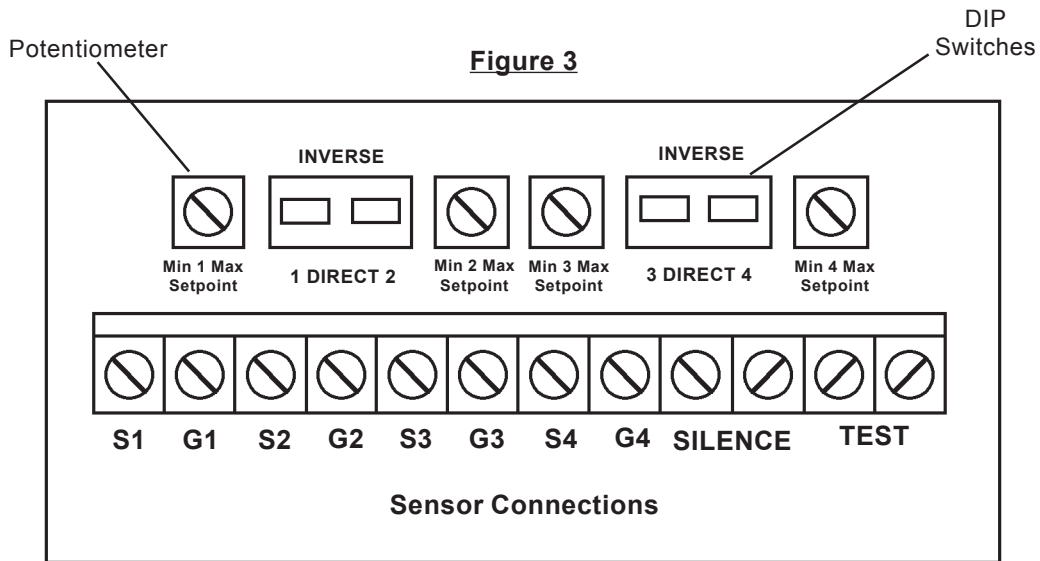

Before putting system into operation, DIP switches and potentiometers (set point) must be set to correctly match the type of sensor you are using. (**Ref to Table 2**). The DIP switches and potentiometers are located above the sensor terminal strip. (Figure 3)

Table 2 describes applications vs. DIP switch settings. Each channel will have its own setting corresponding to the type of sensor being used.

Table 2

| APPLICATION | WARRICK SENSOR | ACTIVATION CONDITION | DIP SWITCH SETTING | SET POINT ADJUSTMENT |
|--|--------------------------------|--|--------------------|---------------------------------------|
| Double Wall Fiberglass Fuel Sensing | DFP-25 | Closes on Detecting Fuel | Inverse ("ON") | NA |
| Double Wall Fiberglass Water Sensing | DWP-25 | Closes on Detecting Water | Inverse ("ON") | NA |
| Double Wall Steel Hydrocarbon/Water Sensing | DSP-2 | Closes on Detecting Hydrocarbon or Water | Inverse ("ON") | NA |
| Double Wall Steel Liquid Sensing | DLP-2 | Closes on Detecting Liquid | Inverse ("ON") | NA |
| Product Level Alarm (Normally Closed Float) | LS-700/800 | Opens on Rising Level | Direct ("OFF") | See Instructions on set point setting |
| Product Level Alarm (Normally Open Float) | LS-700/800 | Closes on Rising Level | Inverse ("ON") | NA |
| Monitoring Well (Hydrocarbon Vapor) Detector | SVP-2 | Resistance Increases on Detecting Vapors | Direct ("OFF") | See Instructions on set point setting |
| Unused Channel | None | NA | Inverse ("ON") | NA |
| Unknown | Unknown Normally Open Switch | Closed on Fault | Inverse ("ON") | NA |
| Unknown | Unknown Normally Closed Switch | Open on Fault | Direct ("OFF") | Consult Factory |

Operation Instructions

Adjusting the Setpoint Position (Except for SVP-2 Sensor)

1. Set the DIP switch to the “OFF” position (direct mode).
2. Turn potentiometer or variable resistor (set point) clockwise until it reaches the end of its rotation. **Do not force the rotation.** When the potentiometer is adjusted to this position, it is set to the maximum setting. If lower sensitivity is required, contact factory for procedure.

Adjusting the Setpoint Position (SVP-2 Sensor Only)

1. After all wiring is complete, apply power to the panel and observe the state of the indicator lights (contacts)
2. If the warning light (contact) is on, determine which channel it is. Find the potentiometer that corresponds to that channel and turn the potentiometer (setpoint) clockwise until the warning light (contact) under question turns off. At this point, turn the potentiometer an additional 1/8th turn, if possible. Repeat this procedure for the other channels. If the potentiometer hits its stop and the warning light stays on, check the sensor for correct wiring and/or fault condition.
3. If the warning light (contact) is not illuminated upon power up, determine which channel it is. Find the potentiometer corresponding to that channel and turn the potentiometer counter clockwise until the warning light turns on. Then turn the potentiometer clockwise until it turns off. At this point, turn the potentiometer clockwise an additional 1/8th turn. Repeat this procedure for the remaining channels. If adjusting the potentiometer does not affect the indicator light under question, check sensor for correct wiring and the position of the DIP switch.
4. If background contamination is present, SVP sensor will need time to stabilize. Install sensor in place for several days before making adjustments. Power does not have to be applied to allow sensor to stabilize. Readjustment may be necessary as sensor reacts to existing conditions.

When using a channel(s) in Inverse Mode (“On” DIP switch position), there is no need to adjust the potentiometer(s). The channel is set to the maximum setpoint.

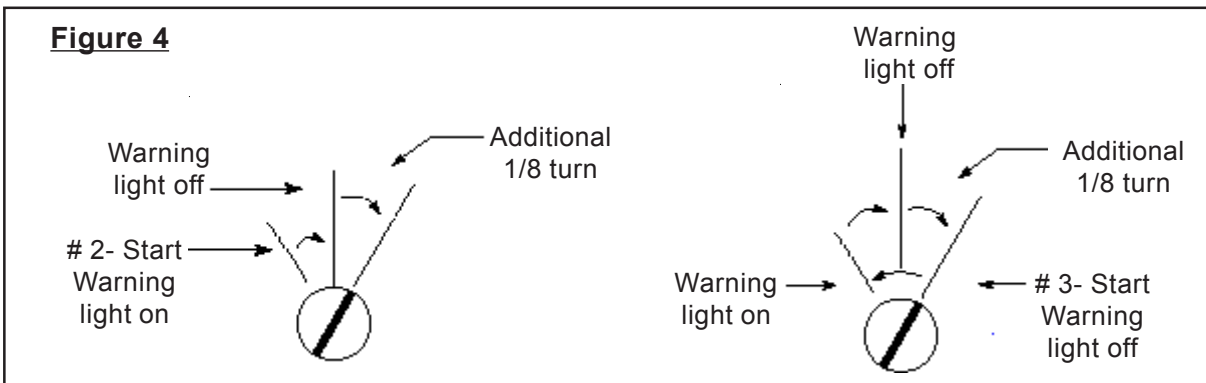

Troubleshooting Guide

A test button can be used to test Series 47. If the system is powered up and there are no fault conditions, the normal contact should be energized. The warning contacts and bell contacts should be de-energized. On pushing the test button, the normal contacts should de-energize, all warning contacts should energize and the bell contact should close. Push the silence pushbutton to de-energize the bell contact. Releasing the test pushbutton should return the system to a normal condition.

If a WARNING contact has been activated and a true fault condition is not found:

1. Recheck position of DIP switch (Table 2).
2. If the DIP switch is in the Inverse Mode (“ON”) position, removing the sensor wiring at the terminal block should de-activate the alarm. Shorting the terminal points should activate. If this does not happen, replace the electronic module.
3. If the DIP switch is in the Direct Mode (“OFF”) position, removing the sensor wiring at the terminal block should activate the alarm. Shorting the terminal points should de-activate the alarm. If this does not happen, replace the electronic module.
4. If the above tests show the operation of the module is correct, and the alarm condition persists, repeat steps 2 and 3 for all field terminal locations. This will check wiring to the sensors. Refer to sensor instructions for details on how to troubleshoot sensor.

Technical Information

Module Replacement

If the electronic module needs to be replaced:

1. Turn off power to the control and load devices
2. Remove the metal partition located across the center of the module (when required).
3. Remove all field wiring terminal blocks from the electronic module. **The field wires do not need to be removed from the terminal blocks.** The terminal blocks separate from the board as show in Figure 5.
4. Remove the four retaining screws from the base of the electronic module. The module can now be removed from the control panel.
5. Install a new module and reinstall all of the terminal blocks.
6. Reinstall the metal partition (when required).
7. Set all DIP switches and potentiometers according to previous instructions.

Figure 5

