

- Reed Switch Protection -

Bulletin No. 133702

CAUTION! Read This Before Installing Unit! Failure to use this unit within the proper current capacity will result in faulty operation!

The "heart" of all GEMS level and flow switches is a hermetically sealed, magnetic reed switch within the unit stem. If used within its current carrying capacity, the reed switch will last many years - 2 million cycles under ideal conditions.

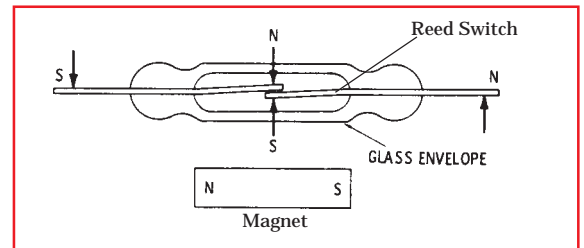

DON'T COOK YOUR REED SWITCH!!!!

Check the current capacity shown on the label of the unit you have purchased, to be sure you are within proper ratings! (See "Switch Ratings - Max. Resistive Load" chart on reverse of this sheet.)

Don't Be Misled:

... By the resistive ratings of the switches. Most applications involve inductive or capacitive loads.

If the reed switch is hooked up directly to the load, it will likely weld the contacts or erode the contact surface; thereby shortening switch life.

... By the wattage ratings of loads.

Low wattage loads are often high inductive devices, making contact protection very important.**

**** See reverse side of this sheet for information on contact protection required when switching inductive loads such as relays, solenoids, motor starters and transformers. Ask about our solid-state relays for loads of 5 - 10 amps. Consult your local electrical engineer or GEMS, if in doubt.**

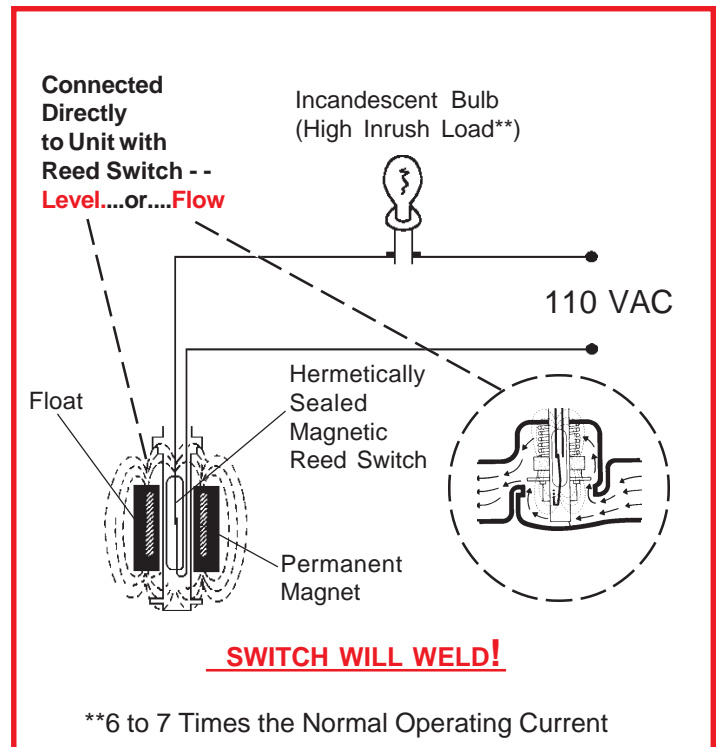

Switch Ratings - Max. Resistive

VA	Volts	Amps AC	Amps DC
10 General Use	0-50	.2	.13
	120	.08	N.A.
	100	N.A.	.3
20 Pilot Duty	0-30	.4	.3
	120	.17	.13
	240	.08	.06
50 General Use	0-50	0.5	0.5
	120	.4	.4
	240	.2	.2
100*	120	.8**	N.A.
	240	.4	N.A.

* Level switch units with 100 VA switches are not U.L. Recognized.

** Limited to 50,000 operations.

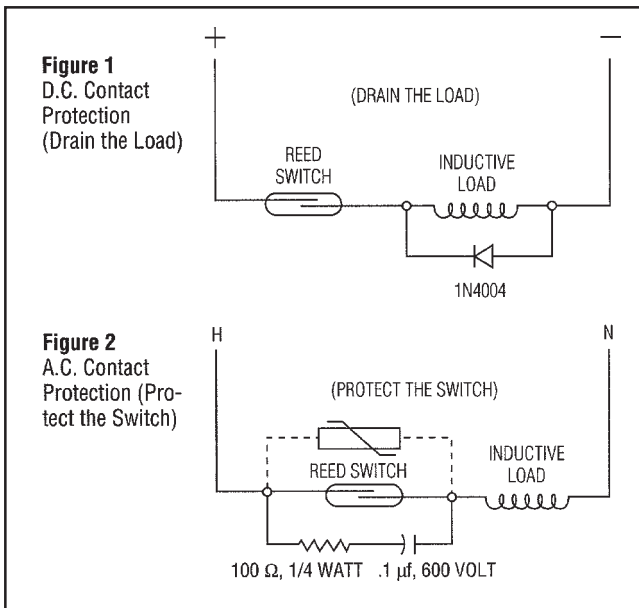

Note: Max. Leakage Current: 4ma @ 120 VAC

Load

Standard reed switches in GEMS level and flow switch units are hermetically sealed, magnetically actuated, make-and-break type. Switches are SPST or SPDT in various ratings, depending on unit model.

Switch Ratings of UL-Listed Units: 10 VA or 20 VA at 120 through 240 VAC, pilot duty. Gems Sensors would be pleased to run life tests on our units with your specific load and issue a report indicating the approximate number of cycles that can be expected.

Contact Protection Requirements

When switching inductive loads such as relays, solenoids and transformers, reed switch contacts require protection in order to insure long, dependable life. When current is interrupted, the inductance or electrical inertia of the load generates a large high frequency voltage, which appears across the switch contacts. If the voltage is large enough, it can break down the medium in the gap between them, making a conductive path. This phenomenon, called "arcing", is the spark you see. Arcing can cause the contacts to burn, weld together or stick; thus, giving unreliable performance. The purpose of protection circuits is to prevent arcing, by shorting this voltage through an alternate path.

Recommended Protection

(D.C.) Use Gems P/N 134579 or 59690

A 1N4004 diode (or equivalent) connected cathode-to-positive, as shown in Figure 1, is recommended. The diode does not conduct when the load is energized, but conducts and shorts out the generated voltage when the switch opens. The generated voltage always acts in series with the applied voltage.

(A.C.) Use Gems P/N 134579, 59690 or 134580

A resistor and capacitor, connected in parallel with the switch, as shown in Figure 2, is recommended. The capacitor is a high impedance to 60 hertz, but is essentially a short circuit to high frequencies of generated voltages.

Part Number	Description	Use With	
		A.C.	D.C.
134580	Switch Transient Protection Assembly R.C. Network.....	X	
134579	Switch Contact Protection Kit Diode.....		X
	Varistor, R.C. Network.....	X	
59690	Transient Varistor.....	X	X