

Side Mounting Float Switch



www.fine-tek.com



INTRODUCTION

WORKING PRINCIPLE

The reed switch relies on two basic scientific principles namely: buoyancy and magnetism.

Buoyancy causes the float (which contains a magnet) to rise with the liquid and magnetism helps open and close the switch.

A change in liquid levels raises or lowers the float up or down. The end of the pivot arm (non float side) contains a permanent magnet that can repel the switch magnet (inside the stationary 'stem' of the entire structure).

When the float magnet moves close to the switch's stationary stem, the float magnet repel the switch magnet which either opens or closes the Electrical circuit.

FEATURES

The side mounted float level sensor (FF series) are manufactured specifically for horizontal mounting on tanks or vessels. They work well as high or low level controls.

1. Both Micro-Switch types and Reed Switches are available. The MicroSwitch type is usable even at ambient temperatures of 100° C maximum.
2. Mounting flanges are custom-made. (JIS, DIN,ANSI).
3. A wide variety of floats for different solution's specific gravities (S.G.) are available.
4. Wetted parts material ranges from plastics, stainless steel, anti-corrosive and explosion proof types.

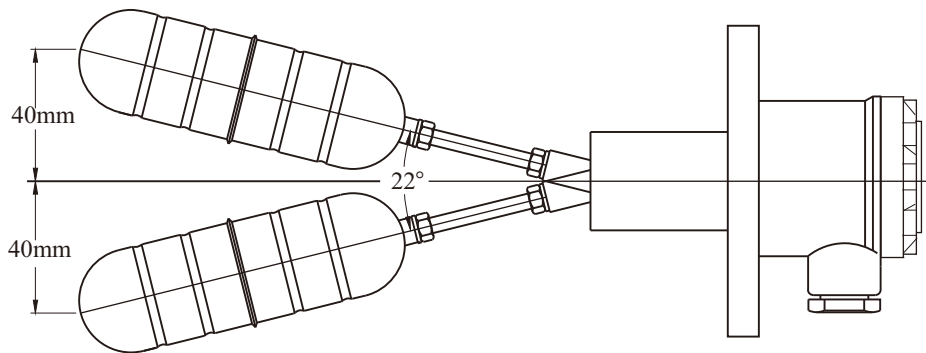

WIRING

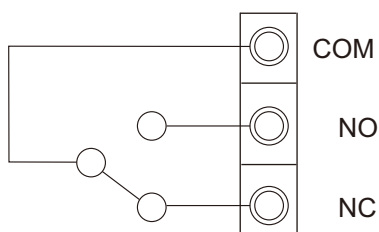

REED SWITCH ---- 1A, 30W 220Vac/200Vdc (FF20, 45, 55, 8□)
MICRO SWITCH ---- 5A/250Vac

CONFIGURATION DIAGRAMS

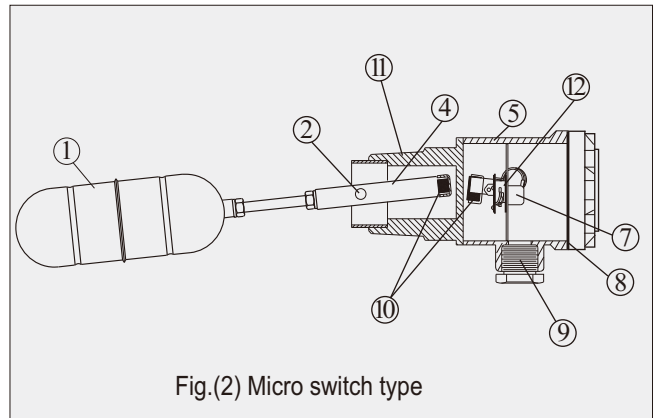
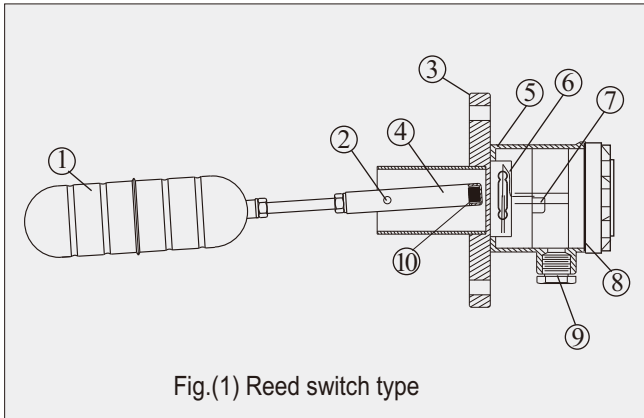

- | | | | |
|-----------|----------------|-------------|-----------------|
| 1. Float | 4. Pivot | 7. Terminal | 10. Magnet |
| 2. Shaft | 5. Housing | 8. O-ring | 11. Screw |
| 3. Flange | 6. Reed Switch | 9. Conduit | 12. Microswitch |
- Conduit/Connection

► The diameter and length of the connecting pipe (of a tank) are in direct proportion.

UNIT: mm

Pipe dia. (A)	45-50	50-55	55-60	60-65	65-70
Length (B) (Max.)	130	140	150	160	170

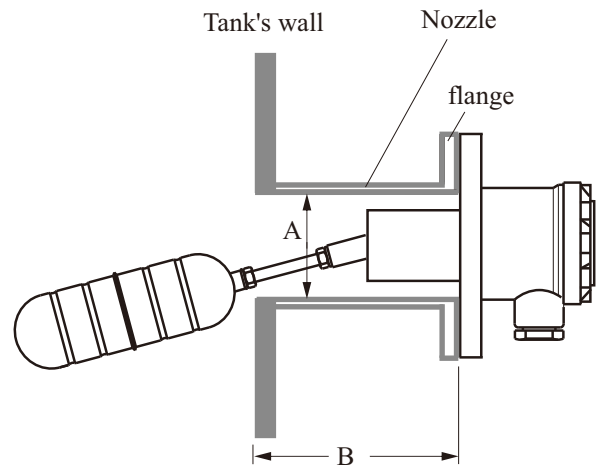

SPECIFICATIONS



MODEL	SPEC.	Operating Temp.	Electrical Contact	Contact Capacity	Contact Element	Housing Spec.	Applicable S.G.
FF10BHM		-20°C~100°C	SPDT(1C)	5A/250Vac	Microswitch	Aluminum Alloy IP65	0.25
FF10CEM		-20°C~100°C	SPDT(1C)	5A/250Vac	Microswitch	Aluminum Alloy IP65	0.65
FF10CEQ		-20°C~100°C	SPDT(1C)	5A/250Vac	Microswitch	Aluminum Alloy IP65	0.65
FF10CLO		-20°C~100°C	SPDT(1C)	5A/250Vac	Microswitch	Aluminum Alloy IP65	0.65
FF10DFM		-20°C~100°C	SPDT(1C)	5A/250Vac	Microswitch	Aluminum Alloy IP65	0.55
FF10DFQ		-20°C~100°C	SPDT(1C)	5A/250Vac	Microswitch	Aluminum Alloy IP65	0.55
FF15HEQ		-20°C~100°C	SPDT(1C)	5A/250Vac	Microswitch	SUS304 IP65	0.8
FF12CEM		-40°C~100°C	SPDT(1C)X2	5A/250Vac	Microswitch	Aluminum Alloy IP65	0.65
FF20BHM		-40°C~200°C	SPDT(1C)	1A, 60W 220Vac/200Vdc	Reed Switch	Aluminum Alloy IP65	0.25
FF20CEM		-40°C~200°C	SPDT(1C)	1A, 60W 220Vac/200Vdc	Reed Switch	Aluminum Alloy IP65	0.65
FF20CEQ		-40°C~200°C	SPDT(1C)	1A, 60W 220Vac/200Vdc	Reed Switch	Aluminum Alloy IP65	0.65
FF20DFM		-40°C~200°C	SPDT(1C)	1A, 60W 220Vac/200Vdc	Reed Switch	Aluminum Alloy IP65	0.55
FF20DFQ		-40°C~200°C	SPDT(1C)	1A, 60W 220Vac/200Vdc	Reed Switch	Aluminum Alloy IP65	0.55
FF20DLO		-40°C~200°C	SPDT(1C)	1A, 60W 220Vac/200Vdc	Reed Switch	Aluminum Alloy IP65	0.55

※ Above-mentioned models are approved by class societies : DNV 、 LR 、 GL 、 BV 、 ABS ◦

SPECIFICATIONS



MODEL \ SPEC.	Operating Temp.	Electrical Contact	Contact Capacity	Contact Element	Housing Spec.	Applicable S.G.
FF40DFM	-20°C~100°C	SPDT(1C)	5A/250Vac	Microswitch	Aluminum Alloy IP65	0.55
FF45DFM	-40°C~200°C	SPDT(1C)	1A, 60W 220Vac/200Vdc	Reed Switch	Aluminum Alloy IP65	0.55
FF50DFM	-20°C~100°C	SPDT(1C)	5A/250Vac	Microswitch	Aluminum Alloy IP65	0.55
FF55DFM	-40°C~200°C	SPDT(1C)	1A, 60W 220Vac/200Vdc	Reed switch	Aluminum Alloy IP65	0.55
FF70/71BHM	-20°C~100°C	SPDT(1C)	3A/250Vac	Microswitch	SUS316 Ex d IIC T3~T6	0.25
FF70/71CFM	-20°C~100°C	SPDT(1C)	3A/250Vac	Microswitch	SUS316 Ex d IIC T3~T6	0.65
FF70/71DFM	-20°C~100°C	SPDT(1C)	3A/250Vac	Microswitch	SUS316 Ex d IIC T3~T6	0.55
FF73GLO	-20°C~100°C	SPDT(1C)	3A/250Vac	Microswitch	SUS316 Ex d IIC T3~T6	0.7
FF75DFM	-20°C~100°C	SPDT(1C)	3A/250Vac	Microswitch	SUS316 Ex d IIC T3~T6	0.55
FF90CLO	-20°C~100°C	SPDT(1C)	5A/250Vac	Microswitch	Aluminum Alloy IP65	0.65

※ Above-mentioned models are approved by class societies : DNV 、 LR 、 GL 、 BV 、 ABS 。

MODEL \ SPEC.	Operating Temp.	Electrical Contact	Contact Capacity	Contact Element	Housing Spec.	Applicable S.G.
FF30A3Q	-20°C~100°C	SPST(1A)	1A, 50W 240Vac/200Vdc	Reed Switch	SUS304 IP65	0.65
FF62DFM	-40°C~350°C	SPDT(1C)	5A/250Vac	Microswitch	Aluminum Alloy IP65	0.55
FF80EFM	-20°C~80°C	SPDT(1C)	1A, 30W 220Vac/200Vdc	Reed switch	PC IP65	0.60
FF81E	-20°C~80°C	SPDT(1C)	1A, 30W 220Vac/200Vdc	Reed switch	—	0.60

MODELS

Order No. F F

Connecting (Refer to p11)
 Float
 10: Single Switch
 12: Dual Switch



► Order No. FF10BHM

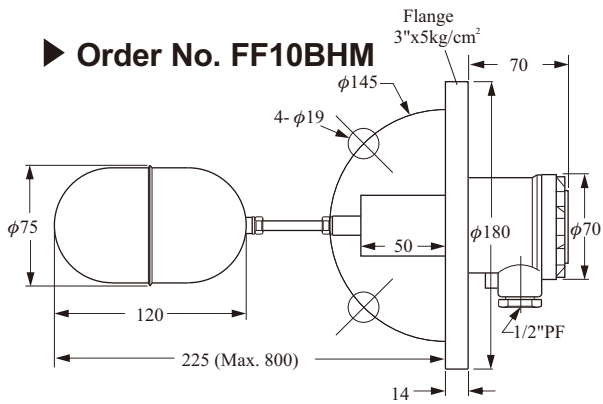

► Order No. FF10CEM

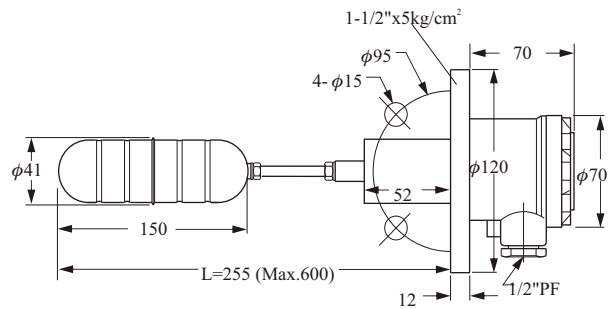

► Order No. FF10CLO

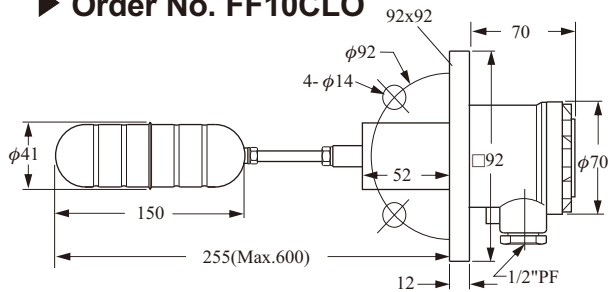

► Order No. FF10CEQ

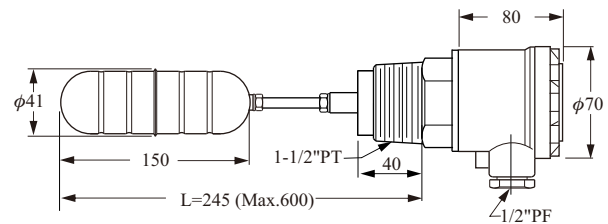

► Order No. FF10DFM

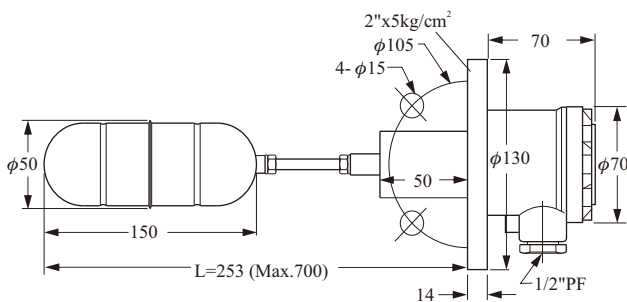

► Order No. FF10DFQ

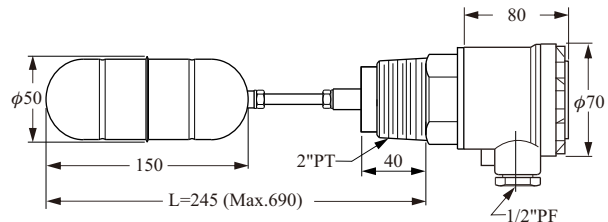

► Order No. FF15HEQ

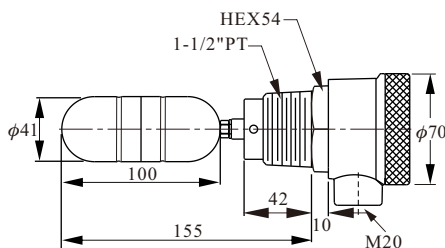

► Order No. FF12CEM

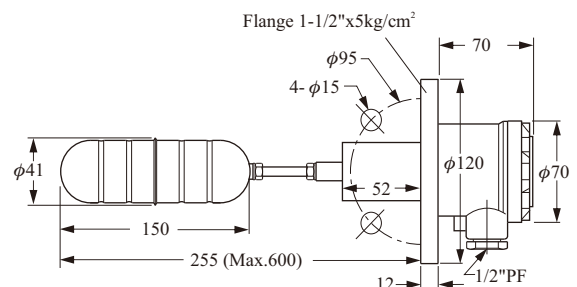

HIGH TEMPERATURE

Order No. FF20

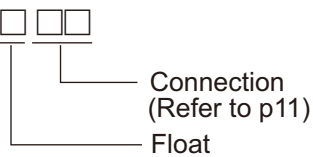

► Order No. FF20BHM

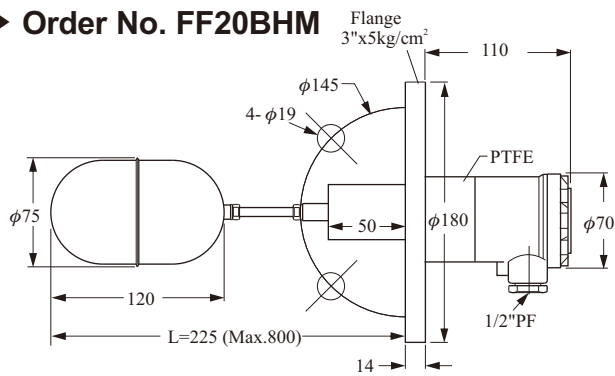

► Order No. FF20CEM

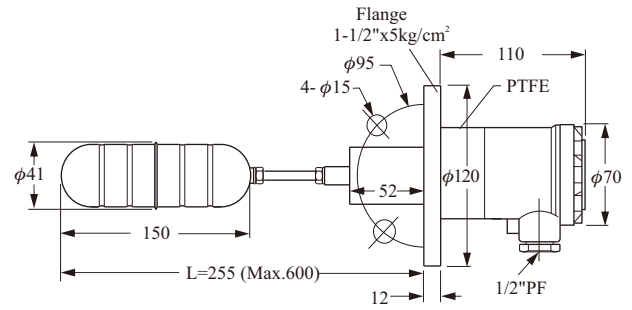

► Order No. FF20CEQ

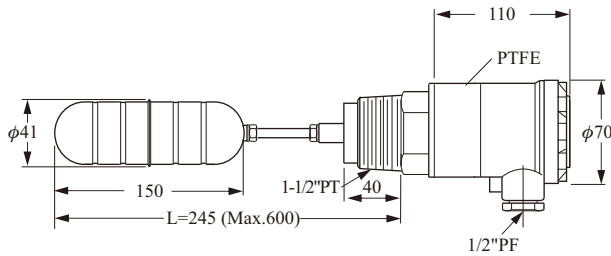

► Order No. FF20DFM

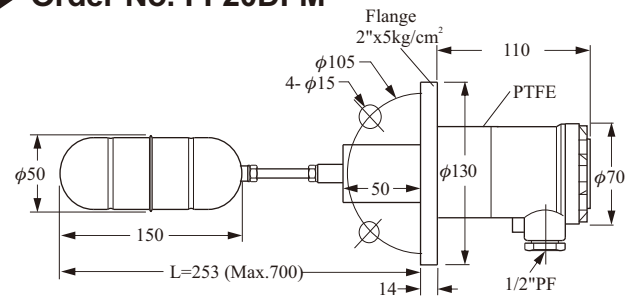

► Order No. FF20DLO

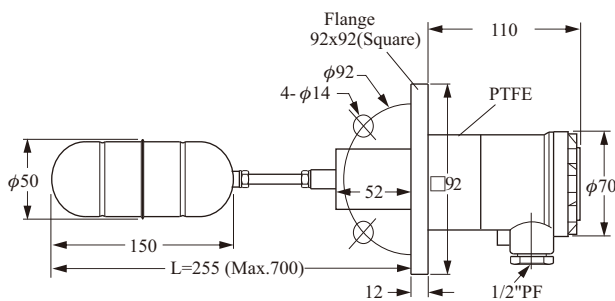

► Order No. FF20DFQ

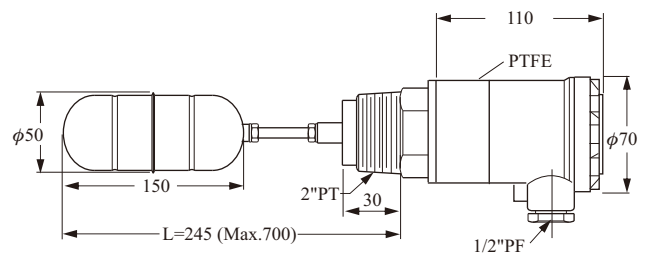

► Order No. FF62DFM

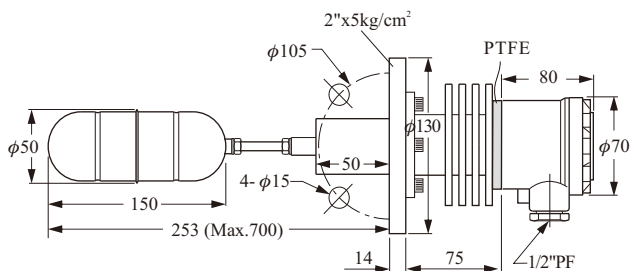

Order No. F F

- Connecting (Refer to page 11)
- Float
- 30: Mini Type
- 40: Double Angle Standard
- 45: Double Angle High Temperature
- 50: Vertical Standard
- 55: Vertical High Temperature

► Order No. FF40DFM

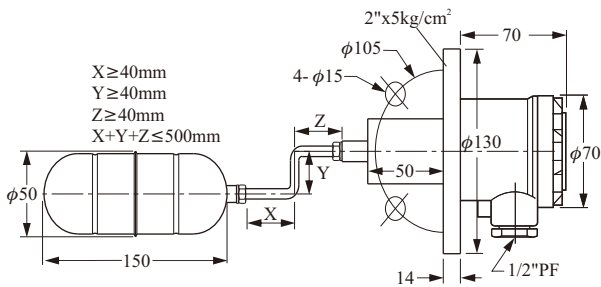

► Order No. FF50DFM

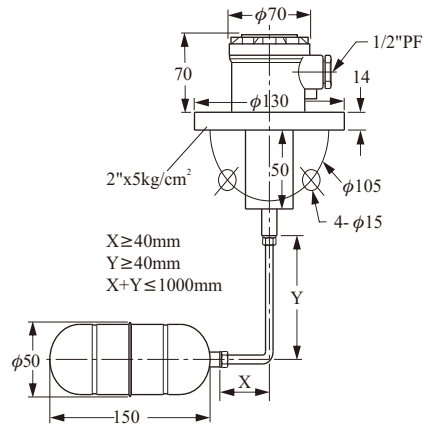

► Order No. FF45DFM

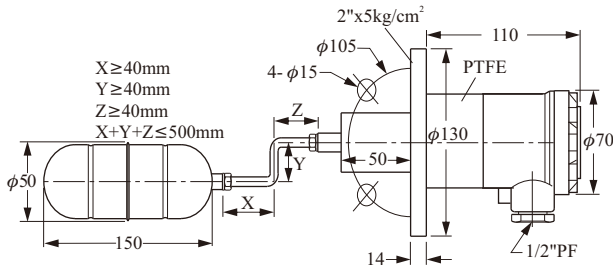

► Order No. FF55DFM

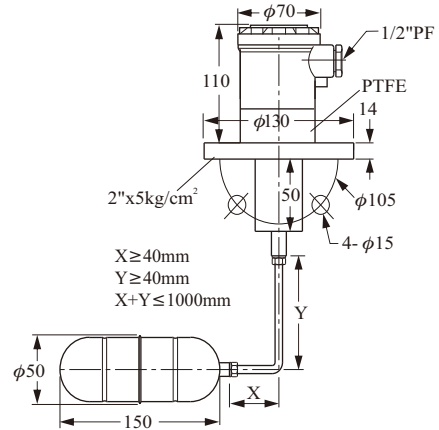

► Order No. FF30A3Q

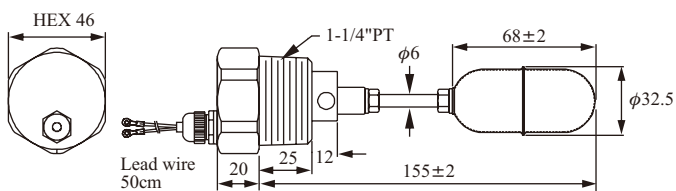

ANTI-CORROSIVE MODELS

FF80EFM --- PC Housing

FF81E --- Without Housing

Wetted parts : P.P.

Cable spec. : PVC 3x0.75 mm²

► **Order No. FF80EFM**

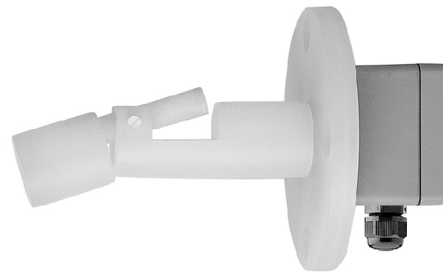
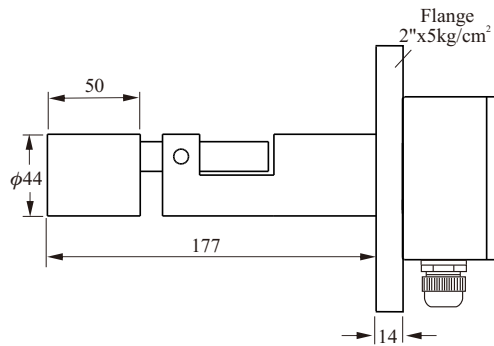

► **Order No. FF81E**

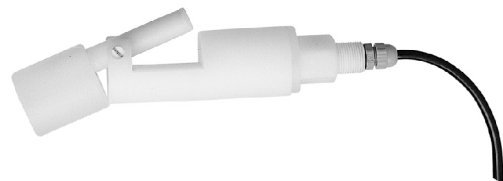
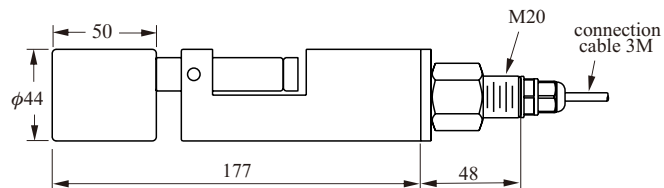

SQUARE FLANGE & TEST ACCESSORIES

► Order No. FF90CLO

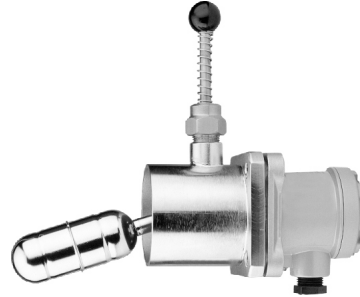
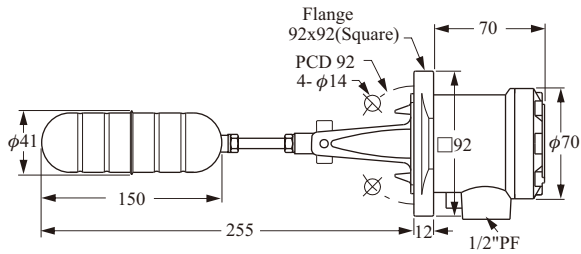

1. Housing material: Aluminum (IP65)
2. Suitable S.G.: >0.65
3. Operation temp.: -20~100°C
4. Contact mode: SPDT(1C)
5. Contact rating: 5A/250Vac
6. Operation pressure: 15kg/cm²
7. Wetted parts: SUS304
8. Weight: (approx.) 1.2 kg

Drill Hole

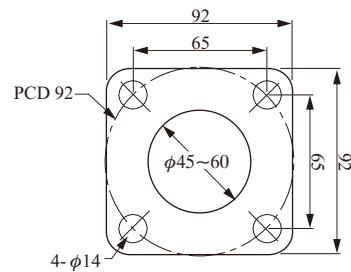

Test Board (Optional)

Material: SS41

Please weld test board with level instrument.
Without level dropping, level instrument can
be checked regularly if functions well.

Check list

- Check if mechanical parts of level switch function well?
- Check if float functions well?

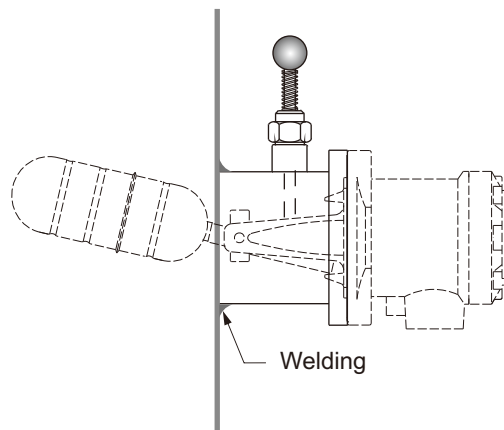
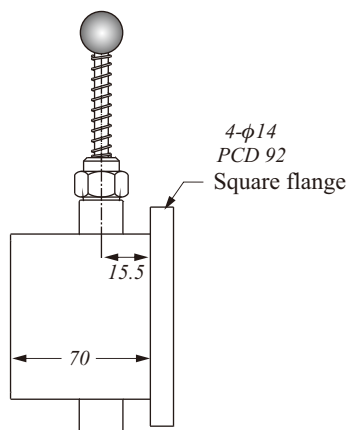
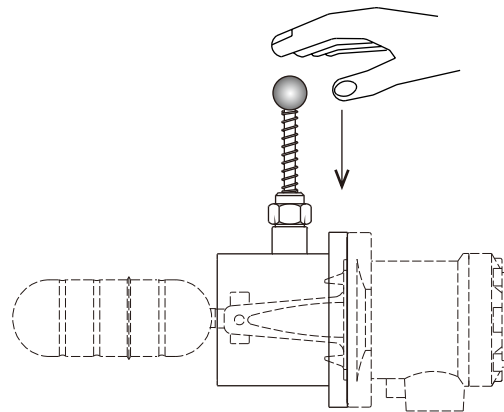

IMPORTANCE FOR INSTALLATION

1. SUS304/SUS316 materials are not available for corrosive application.
2. The cable duct(s) must face downward to prevent moisture seeping in.
3. The float and extension rod must be inserted into the bin completely.
4. Check the liquid's S.G. level before installation.
5. The mounting hole must be larger than the external diameter of the float. (Please refer to p2)
6. Don't mount the devices near the bin's inlet or outlet.

Typical Positioning

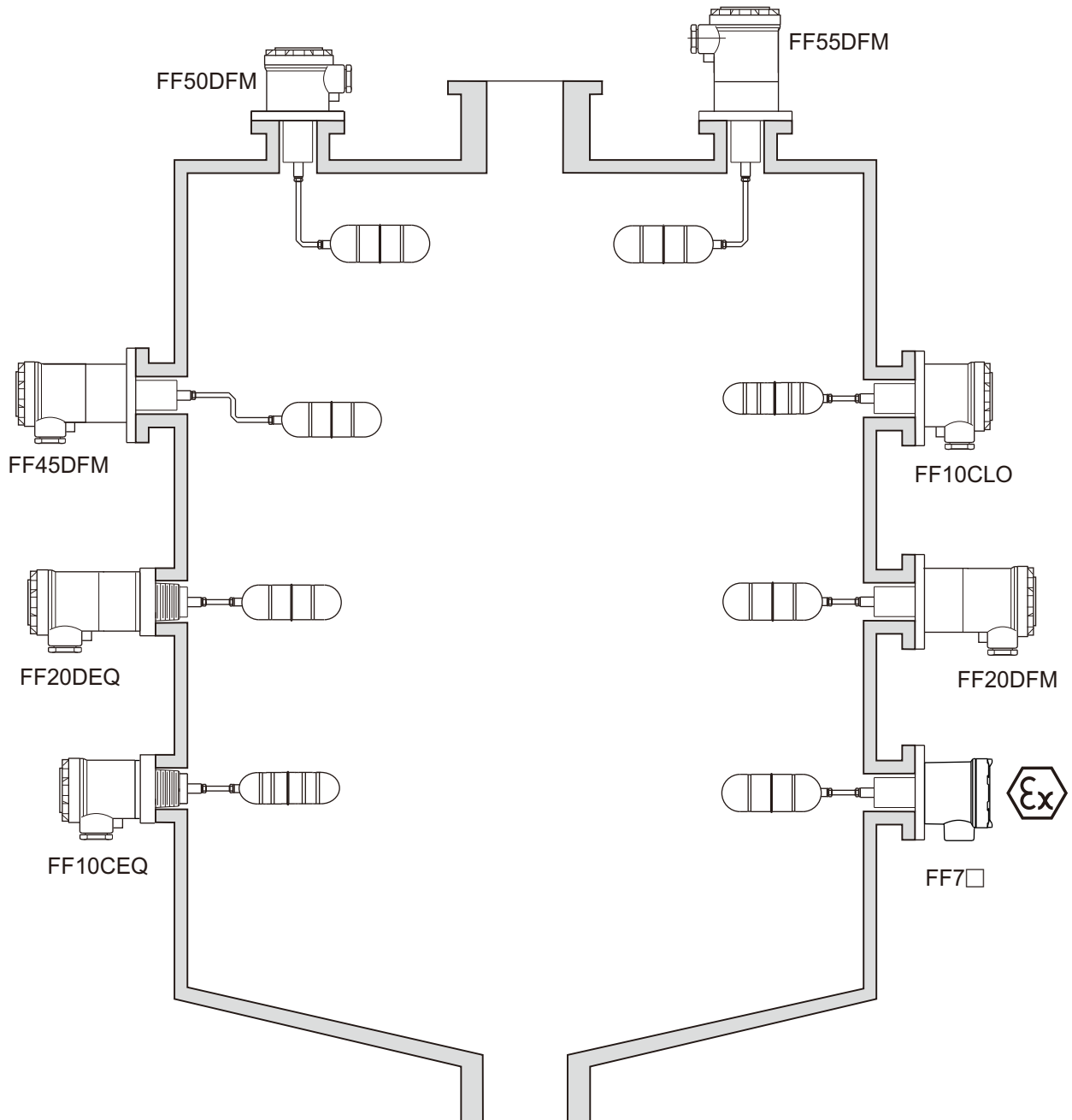

ORDER INFORMATION

Order No. FF **10CEM(S)(T)** - 6

ORDER NO. _____

- | | |
|-----------------------------|-------------------------|
| 10/12: Standard | 55: Vertical High Temp. |
| 15: Mini | 62: High Temp Radiator |
| 20: High Temp. | 80: Anti-acid/alkaline |
| 40: Double Angle Standard | 81: Without Housing |
| 45: Double Angle High Temp. | Only FF81E |
| 50: Vertical Standard | 90: Square Flange |

※ Mini type only available float type(C.G.H)

FLOAT TYPE _____

- B: $\phi 75 \times 120$ (Operation Pressure 10kg/cm² S.G. 0.25)
- C: $\phi 41 \times 150$ (Operation Pressure 15kg/cm² S.G. 0.65)
- D: $\phi 50 \times 150$ (Operation Pressure 30kg/cm² S.G. 0.55)
- G: $\phi 41 \times 125$ (Operation Pressure 15kg/cm² S.G. 0.7)
- H: $\phi 41 \times 100$ (Operation Pressure 15kg/cm² S.G. 0.8)

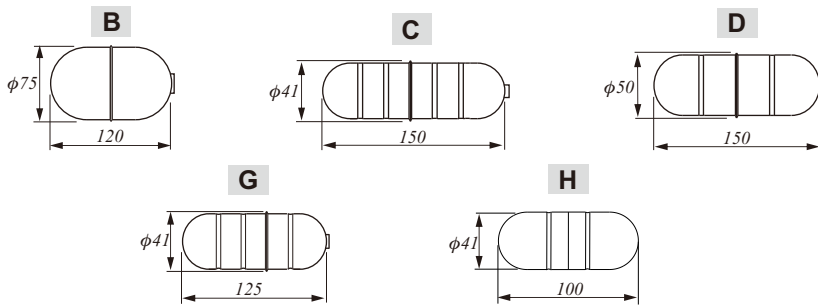

CONNECTING TYPE _____

- | | | |
|-----------------|--------------------------|------------------|
| E: 1-1/2" (40A) | M: 5 kg/cm ² | W: PN 10 (10Bar) |
| F: 2" (50A) | N: 10 kg/cm ² | X: PN 16 (16Bar) |
| G: 2-1/2" (65A) | O: 150 Lbs | Y: PN 25 (25Bar) |
| H: 3" (80A) | P: 300 Lbs | Z: PN 40 (40Bar) |
| I: 4" (100A) | Q: PT | S: Others |
| J: 5" (125A) | R: PF(G) | |
| K: 6" (150A) | T: BSP | |
| L: 92x92 | U: NPT | |

CUSTOM LENGTH(L) (UNIT: mm) _____

TEST BOARD _____

MATERIAL _____

- Without: SUS304 -6: SUS316 -9: SUS316L

- ※ Total product length margin of error is ± 5 mm
- ※ Characteristics, specifications and dimensions are subject to change without notice.
- ※ Please contact your nearest distributor for further information.

EXPLOSION PROOF

Order No. FF

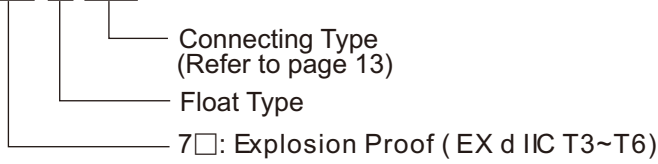

► Order No. FF 70 CEQ

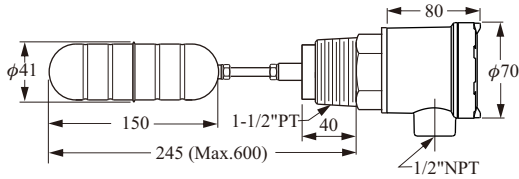

► Order No. FF 70 DFQ

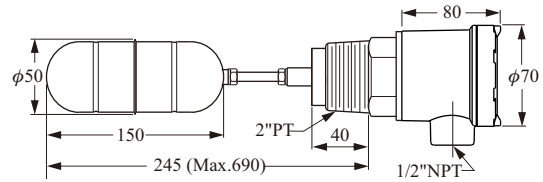

► Order No. FF 71 BHM

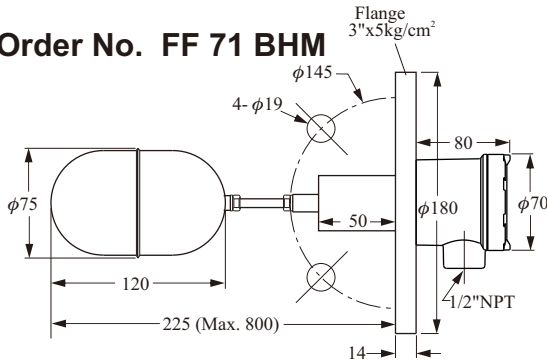

► Order No. FF 71 CEM

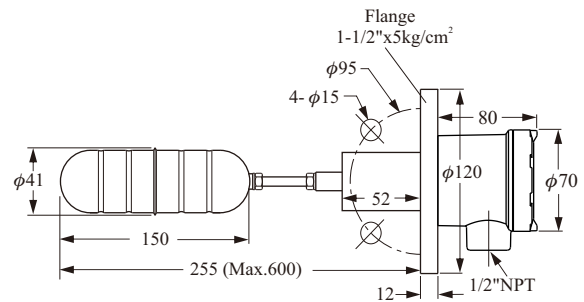

► Order No. FF 71 DFM

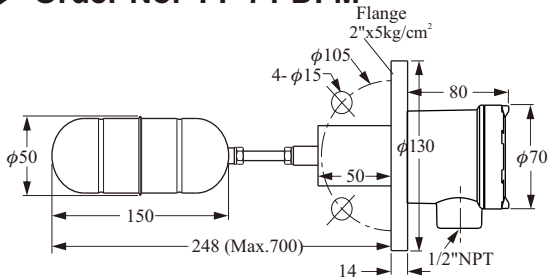

► Order No. FF 73 CLO

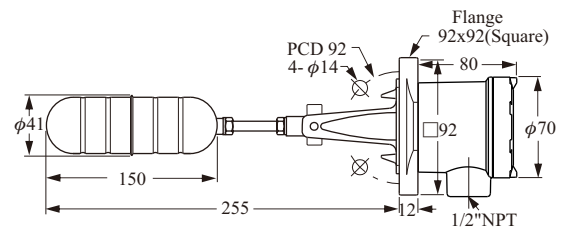

► Order No. FF 74 DFM

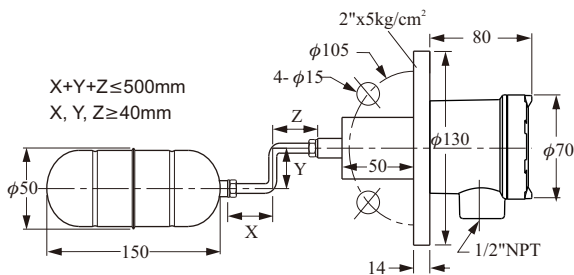

► Order No. FF 75 DFM

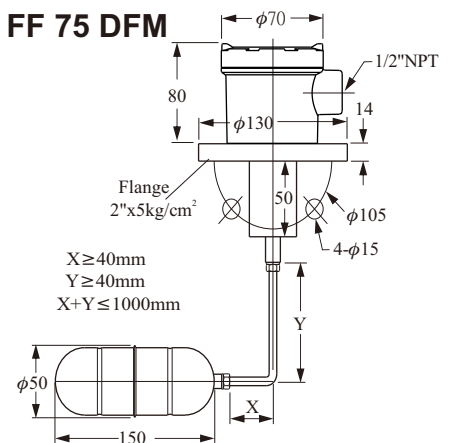

ORDER INFORMATION

Order No. FF **70** **C** **EM** **S** **T** - 6

ORDER NO. _____

- 70: LF70 Explosion Proof
- 71: LF71 Explosion Proof
- 73: LF73 Explosion Proof
- 74: LF74 Explosion Proof
- 75: LF75 Explosion Proof

FLOAT TYPE _____

- B: $\phi 75 \times 120$ (Operation Pressure 10kg/cm² S.G. 0.25)
- C: $\phi 41 \times 150$ (Operation Pressure 15kg/cm² S.G. 0.65)
- D: $\phi 50 \times 150$ (Operation Pressure 30kg/cm² S.G. 0.55)
- G: $\phi 41 \times 125$ (Operation Pressure 15kg/cm² S.G. 0.7)
- H: $\phi 41 \times 100$ (Operation Pressure 15kg/cm² S.G. 0.8)

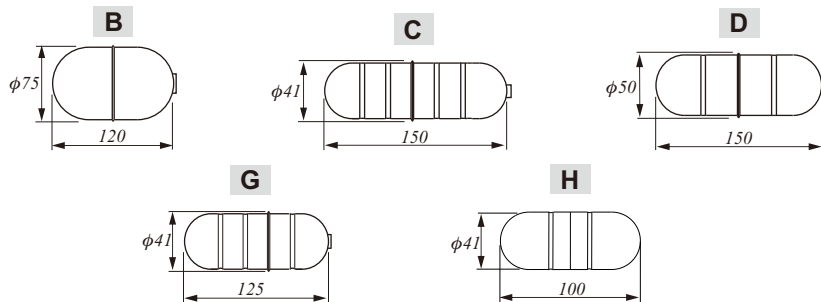

CONNECTING TYPE _____

- | | | |
|-----------------|-------------------------|-----------------|
| E: 1-1/2" (40A) | M: 5 kg/cm ² | W: PN10 (10Bar) |
| F: 2" (50A) | N: 10kg/cm ² | X: PN16 (16Bar) |
| G: 2-1/2" (65A) | O: 150 Lbs | Y: PN25 (25Bar) |
| H: 3" (80A) | P: 300 Lbs | Z: PN40 (40Bar) |
| I: 4" (100A) | Q: PT | S: Others |
| J: 5" (125A) | R: PF(G) | |
| K: 6" (150A) | T: BSP | |
| L: 92x92 | U: NPT | |

CUSTOM LENGTH(L) (UNIT: mm) _____

TEST ACCESSORY _____

MATERIAL _____

- Without: SUS304
- 6: SUS316
- 9: SUS316L

※ Total product length margin of error is ± 5 mm
 ※ Characteristics, specifications and dimensions are subject to change without notice.
 ※ Please contact your nearest distributor for further information.

Global Network

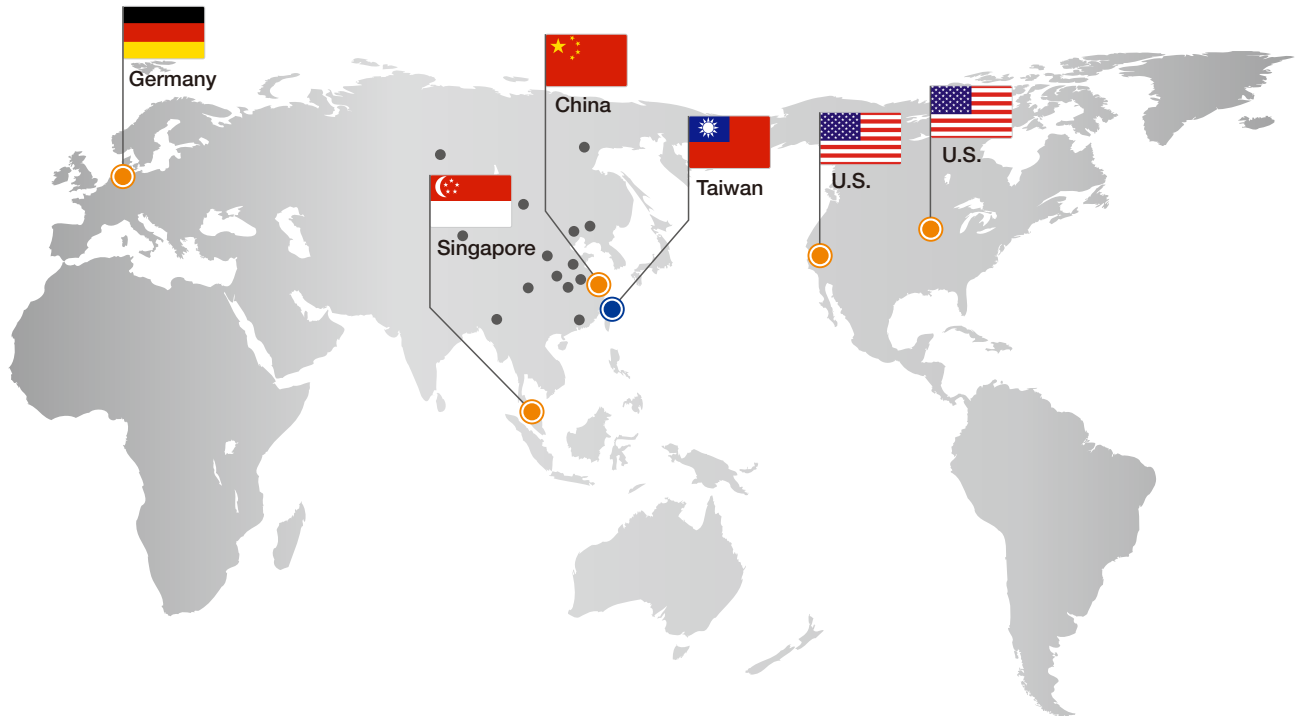

■ Asia

● Taiwan

FINETEK CO., LTD. - Taipei Head Quarter
No.16, Tzuchiang St., Tucheng Industrial Park
New Taipei City 236, Taiwan
TEL: 886-2-2269-6789
FAX: 886-2-2268-6682
EMAIL: info@fine-tek.com

FINETEK CO., LTD. - I-Lan Factory

TEL: 886-3-990-9669
FAX: 886-3-9909659

FINETEK CO., LTD. - Taichung Branch

TEL: 886-4-2337-0825
FAX: 886-4-2337-0836

FINETEK CO., LTD. - Kaohsiung Branch

TEL: 886-7-333-6968
FAX: 886-7-536-8758

● China

FINE AUTOMATION CO., LTD. - Shanghai Factory

No.451 DuHui Rd, MinHang District, Shanghai,
China 201109
TEL: 86-21-6490-7260
FAX: 86-21-6490-7276
EMAIL: info.sh@fine-tek.com

● Singapore

FINETEK PTE LTD. - Singapore Office

No. 60 Kaki Bukit Place, #07-06 Eunos
Techpark 2 Lobby B, Singapore 415979
TEL: 65-6452-6340
FAX: 65-6734-1878
EMAIL: info.sg@fine-tek.com

● Indonesia

FINETEK CO., LTD. - Indonesia Office

Ruko Golden 8 Blok H No.40
Gading Serpong, Tangerang, Indonesia
TEL: 62 (021)-2923-1688
FAX: 62 (021)-2923-1988
EMAIL: info.id@fine-tek.com

■ North America

● California, U.S.

APLUS FINETEK SENSOR INC. - US Office
355 S. Lemon Ave, Suite D, Walnut,
CA 91789
TEL: 1 909 598 2488
FAX: 1 909 598 3188
EMAIL: info@aplusfine.com

● Illinois, U.S.

APLUS FINETEK SENSOR INC.
TEL: 1 815 632-3132
FAX: 1 815 716 8464
EMAIL: info@aplusfine.com

■ Europe

● Germany

FineTeK GmbH - Germany Office
Frankfurter Str. 62, OG D-65428
Ruesselsheim, Germany
TEL: +49-(0)6142-17608-0
FAX: +49-(0)6142-17608-20
EMAIL: info@fine-tek.de



Distributor: