

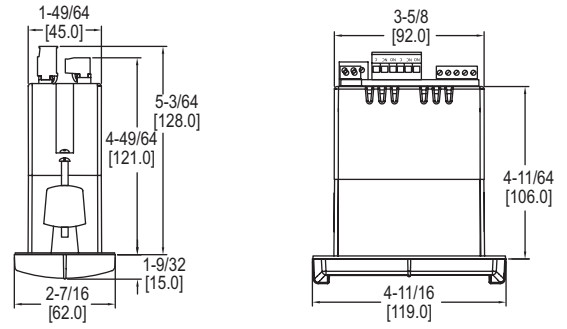

SERIES APM, MPM & PPM

DUAL LINE CONFIGURABLE PANEL METERS

1/8 DIN Multi-Pump Alternation Control, Open-Channel Flow, Rate and Totalizer



The Series PM's are a series of 1/8 DIN digital panel meters engineered to take in multiple inputs from a variety of instrumentation for the purpose of displaying or controlling a process parameter.

The **Series APM Dual Line Configurable Panel Meter** is specifically designed for displaying flow rate and total from a flow meter with an analog output such as 4 to 20 mA or 0 to 10 V. The APM is particularly well-suited for flow applications and can display flow rate and total at simultaneously.

The **Series MPM Dual Line Configurable Panel Meter** has the ability to obtain non-linear input signals and linearize them with simple to use math functions such square-root extractor, weirs and flumes exponential linearizer, horizontal round tank linearizer or general purpose 32-point linearizer. Unit accepts 0 to 20 mA, 4 to 20 mA, 0 to 5 V, or ± 10 V inputs and requires 85 to 265 VAC or 12/24 VDC power supply. Choose from RS-232, RS-422/485 serial communication options or any available expansion modules, accessories and enclosures.

The **Series PPM Dual Line Configurable Panel Meter** displays flow rate and total simultaneously, with a programmable relay and 4 to 20 mA options for flow rate or flow total. The PPM is designed for displaying flow rate and total from a pulsed input provided by open collector, NPN, PNP, TTL, switch contact, sine wave, or square wave.

FEATURES/BENEFITS

- Three levels of password protection
- Math functions for flow & round horizontal tanks
- 32-point linearization, square root or programmable exponent
- Multi-pump alternation control
- Rate displayed as units per second, minute, hour, or day
- Total, grand total or non-resettable grand total
- Two or four relays & isolated 4 to 20 mA output options
- External 4-relay & digital I/O expansion modules
- RS-232, RS-422/485 serial communication options

APPLICATIONS

- Level monitoring
- Pump control
- Flow rate indication
- Flow totalization
- Open channel flow monitoring
- Process control

| MODEL CHART | | | | | |
|-------------|---------|---------|---------------|----------|------------|
| Model | Model | Model | Power | Output 1 | Output 2 |
| APM-100 | MPM-100 | PPM-100 | 85 to 265 VAC | None | None |
| APM-101 | MPM-101 | PPM-101 | 85 to 265 VAC | None | 4 to 20 mA |
| APM-120 | MPM-120 | PPM-120 | 85 to 265 VAC | 2 relays | None |
| APM-121 | MPM-121 | PPM-121 | 85 to 265 VAC | 2 relays | 4 to 20 mA |
| APM-140 | MPM-140 | PPM-140 | 85 to 265 VAC | 4 relays | None |
| APM-141 | MPM-141 | PPM-141 | 85 to 265 VAC | 4 relays | 4 to 20 mA |
| APM-200 | MPM-200 | PPM-200 | 12 to 24 VDC | None | None |
| APM-201 | MPM-201 | PPM-201 | 12 to 24 VDC | None | 4 to 20 mA |
| APM-220 | MPM-220 | PPM-220 | 12 to 24 VDC | 2 relays | None |
| APM-221 | MPM-221 | PPM-221 | 12 to 24 VDC | 2 relays | 4 to 20 mA |
| APM-240 | MPM-240 | PPM-240 | 12 to 24 VDC | 4 relays | None |
| APM-241 | MPM-241 | PPM-241 | 12 to 24 VDC | 4 relays | 4 to 20 mA |

SPECIFICATIONS

| | |
|--|--|
| Input: APM: 0 to 20 mA, 4 to 20 mA, 0 to 5 V, or ± 10 V inputs; MPM: 0 to 20 mA, 4 to 20 mA, 0 to 5 V, or ± 10 V; PPM: Field selectable: Pulse or square wave 0 to 5 V, 0 to 12 V, or 0 to 24 V @ 30 kHz; TTL; open collector 4.7 k Ω pull-up to 5 V @ 30 kHz; NPN or PNP transistor, switch contract 4.7 k Ω pull-up to 5 V @ 40 Hz. Input Impedance: 50 to 100 Ω . Accuracy: $\pm 0.03\%$ of calibrated span ± 1 count, square root & programmable exponent accuracy range: 10-100% of calibrated span. Power Requirements: 85 to 265 VAC 50/60 Hz, 90 to 265 VDC, 20 W max or 12 to 24 VDC $\pm 10\%$, 15 W max. Display: Dual-line 6-digit display, 0.60 in and 0.46 in. Decimal Points: Five positions, user selectable. Temperature Limits: Operating: -40 to 149°F (-40 to 65°C); Storage: -40 to 185°F (-40 to 85°C). | Enclosure Rating: NEMA 4X, IP65 front. Electrical Connections: Removable screw terminal blocks accept 12 to 22 AWG wire, RJ45 for external relays, digital I/O, and serial communication adapters. Output Signal: 4 to 20 mA. Power Consumption: 85 to 265 VAC models: 200 mA @ 24 VDC; 12 to 24 VDC models: 100 mA @ 24 VDC; Second supply with output 2 models: 40 mA @ 24 VDC. Switch Rating: 2 or 4 SPDT (Form C) internal and/or 4 SPST (Form A) external; rated 3 A @ 30 VDC and 125/250 VAC resistive load; 1/14 HP @ 125/250 VAC for inductive loads. Time Delay: 0 to 999.9 s, on & off relay time delays; programmable and independent for each relay. Shipping Weight: 9.5 oz (269 g). Agency Approvals: CE, UL. |
|--|--|

OPEN CHANNEL FLOW CAPABILITY

Series APM when utilized with an ultrasonic level transmitter, such as the Mercoid Series ULT, provides an economical way to measure open channel flow.

DIFFERENTIAL PRESSURE FLOW

The APM can display flow rate and total by extracting the square root from the 4 to 20 mA signal from a differential pressure transmitter, such as the Dwyer 629, that is being used with a flow element such as Dwyer orifice plate Series OP or TE. The user-selectable, low-flow cut-off feature gives a reading of zero when the rate is below a user selectable value.

PUMP CONTROL

With the two or four contact output option the APM or MPM can be used as a programmable pump controller when used with a Dwyer level transmitter. The APM also has programmable on and off points for up to four pumps, quadruplex pumping systems with alternation capability. When using the 4-relay model with the four external relay accessory, the APM can do 8 contacts for any combination of pump control and 8 programmable alarms.

ACCESSORIES

| Model | Description |
|--------|---|
| PMA-01 | RS-232 serial adapter |
| PMA-02 | Meter copy cable |
| PMA-03 | RS-422/485 serial adapter |
| PMA-04 | RS-232 to RS-422/485 isolated converter |
| PMA-05 | RS-232 to RS-422/485 non-isolated converter |
| PMA-06 | USB to RS-232 non-isolated converter |
| PMA-07 | USB to RS-422/485 isolated converter |
| PMA-08 | USB to RS-422/485 non-isolated converter |
| PMA-09 | Snubber |
| PMA-10 | DIN rail mounting kit for two modules |
| PMA-11 | 4 relay expansion module |
| PMA-12 | 4 digital inputs and 4 digital outputs module |