

CATALOGUE 2026

Professional and innovative
flow measuring & monitoring solutions

- Vortex flow meter
- Thermal mass flow meter
- Pitot tube flow meter
- Micro flow meter
- Efficiency measurement
- IoT monitoring

About Comate Intelligent Sensor

Hefei Comate Intelligent Sensor Technology Co.,Ltd (COMATE) is a world leading gas/air/steam flow measurement solution provider. Our R&D team comes from the University of Science and Technology of China and have been researching in the flow measurement technology since 2008. We are delegated to help the users on solving their measurement challenge with our origin and innovative technologies ever since.

Comate has set up a complete product line including thermal mass flow meter, vortex flow meter, micro flow meter and pitot tube flow meter. Thanks to our strong R&D force, we are able to answer to specific requirements from different industries, such as our auditing and pre-auditing set specially customized for compressed air applications, which has help thousands of compressor distributors on improving their sales of the machines.

Up to today, Comate's products has been used in over 60 countries & areas, and are welcomed by end users for their stability and durability. Our users covers different industrial sectors such as in automotive and parts manufacturing, home appliance manufacturing, optoelectronics, food, pyroelectricity, buliding materials, metallurgy, textile, printing and other industries, fully meet customer application requirements.



What's the meaning of cooperating with Comate?

- Outstanding design team, long-term R&D experience in flow meter manufacturing
- Professional ability to provide customized solution for special applications
- Comprehensive quality control and customer service system



Don't be hesitated to call us at info@comatemeeter.com if you have any questions.

Our Clients & Partners

Most of our users are the leading companies from various industries around the world and we have won the recognition with our high-performance and highly reliable products.



International Exchange & Cooperation

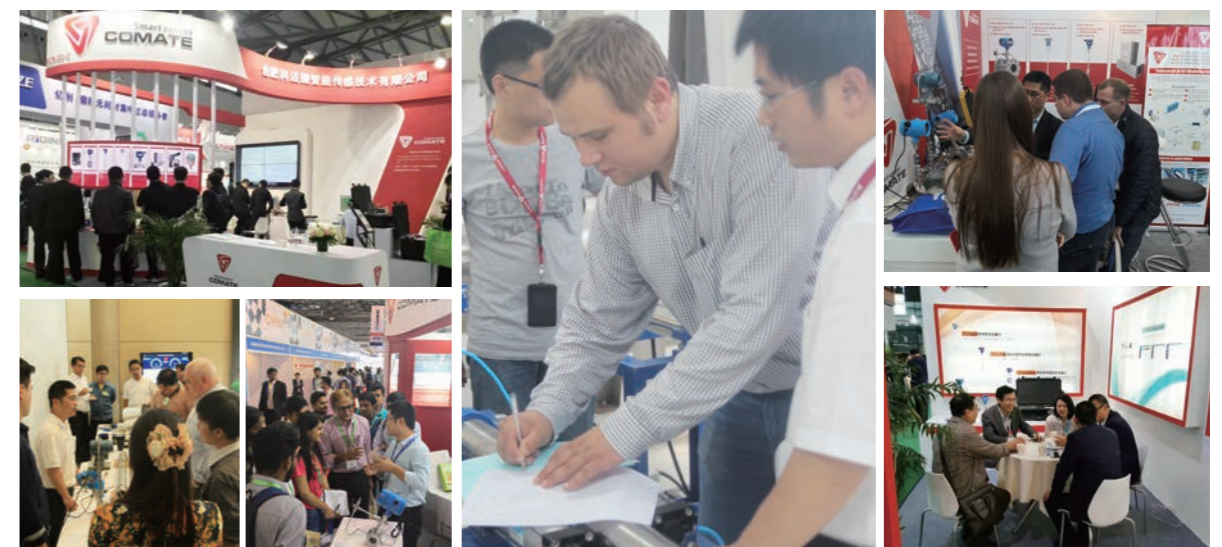

Qualification Honors



- 1 The Ministry of Science and Technology's first "Excellent Enterprise in Innovation and Entrepreneurship Competition" award
- 2 Second Prize of China Energy Conservation and Environmental Protection Patent Award
- 3 National high-tech enterprise with multiple core invention patents and software copyrights
- 4 Research Unit of 'Innovation Fund for Technology-based SMEs'
- 5 Gazella company, Technology little giant Enterprise
- 6 Five "High Tech Technology products of Anhui Province"
- 7 Passed European EMC Test

All COMATE products will be carefully calibration before delivery. Our engineers are available to assist you 7-24 if you need. Pls contact us directly if you have any questions.

Flow meter's calibration services are performed in Comate's test and calibration laboratory. we have other cooperative laboratories for other instruments. All calibration equipment can be tracked to National standard Center and recalibrated regularly.



Calibration Service

- > Accuracy 0.2%
- > Calibration Range:0-8000m3/hr
- > Pressure 0~0.6Mpa
- > Pipe Size DN15~DN300
- > Medium: Air
- > Reference equipment: Sonic nozzle

Test on-site

- > Flow and consumption measurement
- > Pressure measurement
- > Temperature measurement
- > Leak detection
- > Days or weeks data record
- > Energy Consumption audit

Smart sensor COMATE				Hefei Comate Intelligent Sensor Technology Co.,Ltd			
Calibration report							
Certificate No.	KMJ2022-T-0900303		Instrument	Thermal Mass Flowmeter			
Model No.	TGF600-1-1-B-1-N-T-M-N-1-1-200						
Verification Regulator	JJG 1132-2017 《Thermal Mass Flowmeter》		Serial No.	TF6-2209011			
Conclusion	Qualified Accuracy : 1.5%RD±0.5%FS						
Main measurement standards used in this calibration							
Name	Standard Meter Calibration System		Certificate No.	LLq12014-2-090051			
Type/Specification	LJQ-150P		Maximum permissible error	Urel=0.3%(K=2)			
Number	14ALH008		Ambient temperature	19.665 °C			
Relative Humidity	55.7%RH		Valid until	2022/4/1			
Remark: 1.Our company are only responsible for complete calibration report that has the stamp of "合肥科迈智能传感技术有限公司检定专用章"							
2. The result of calibration in this report is only for certain instrument where is calibrated in this time							
3.Please keep this report properly							
Results of calibration and additional explanation							
Calibration velocity:	0.3-30Nm³		Calibration media:	Air			
Calibration pipe size:	80m Reference condition:20°C,101.325kPa						
Calibration point	Designed value (Nm³/h)	Standard value (Nm³/h)	Indicated value (Nm³/h)	Result %RD	Repeatability		
1	27.143361	27.22613	27.40715478	0.66	0.08		
2	72.382295	72.08316	72.35709407	0.38	0.16		
3	199.05131	198.9513	196.1566025	-1.40	0.21		
4	325.72033	324.7231	328.9125468	1.29	0.29		
5	506.67606	503.0803	498.2324972	-0.96	0.14		
Inspector:	Checked By:		Approved by:				
Instruction: If customer need to verify the result of this calibration under the instruction of manufacturer or that of technical regulation, please do the re-calibration before March. 15 th 2023.							
Date for Verification:	2022.03.15		Valid Until:	2023.3.15			
Address:2nd floor, Building D2, Hefei Innovation Industrial Park, No.800 Wangjiang West Road,Hefei Tech Development Zone, Hefei, Anhui Province, China							
Fax: 0551-5316075 Tel: 0551-3653542			website:http://www.comatemeter.com				

Power Efficiency Analyzing Report of Compressor						
Customer's Name	Comate Meter					
Customer's Address	Hefei, Anhui					
Specification of tested compressor						
Model	XXXXXXXXXX	Manufacturer	XXXXXXXXXX			
Year of production	2018/8	Rated power	0.05			1.0W
Rated air production	13.00 m³/min	Specific Power	0.05			1.0W/m³/min
Accountability of air compressor parameters						
Model	XXXXXXXXXX	Manufacturer	XXXXXXXXXX			
Rated air production	14.00 m³/min	Rated power	0.05			1.0W
Rated specific Power	4.52 W/m³/min	Power consumption per unit of air	0.000			0.000 kWh/m³
Test Data						
Test standard Date	0.02	Test Pressure consumption	0.02	0.04	Power consumption per unit of air	0.000 kWh/m³
Test range	0.00	Test time	0.00	0.00	Test time	0.00
Remark 1: Water consumption per unit of air is test pressure consumption						
	Pressure (kPa)	Flowrate (m³/min)	Power (W)	Specific Power (W/m³/min)	Specific Power (kWh/m³)	
0.02	0.04	0.02	0.04	0.00	0.000	
0.04	0.04	0.04	0.08	0.00	0.000	
Remark 2: Specific Power is power divided by P2D flow						
Flowrate (m³/min)	Power (W)	Specific Power (W/m³/min)	Flow rate (m³/min)	Power (W)	Specific Power (W/m³/min)	
0.02	0.04	0.00	0.04	0.08	0.00	
0.04	0.08	0.00	0.08	0.16	0.00	
0.06	0.12	0.00	0.12	0.20	0.00	
0.08	0.16	0.00	0.16	0.25	0.00	
Return on investment						
	Power (W)	Flowrate (m³/min)	Specific Power (W/m³/min)	Power (W)	Flowrate (m³/min)	Specific Power (W/m³/min)
0.02	0.04	0.02	0.00	0.04	0.04	0.00
0.04	0.08	0.04	0.00	0.08	0.08	0.00
0.06	0.12	0.06	0.00	0.12	0.12	0.00
0.08	0.16	0.08	0.00	0.16	0.16	0.00
0.10	0.20	0.10	0.00	0.20	0.20	0.00

COMATE has the Origin technology from the basis, design & manufacture all our products from hardware to software and Every COMATE product will be calibrated and preset before shipment. Data reserved in our PHM system to ensure quality traceable.

Supply Chain Management

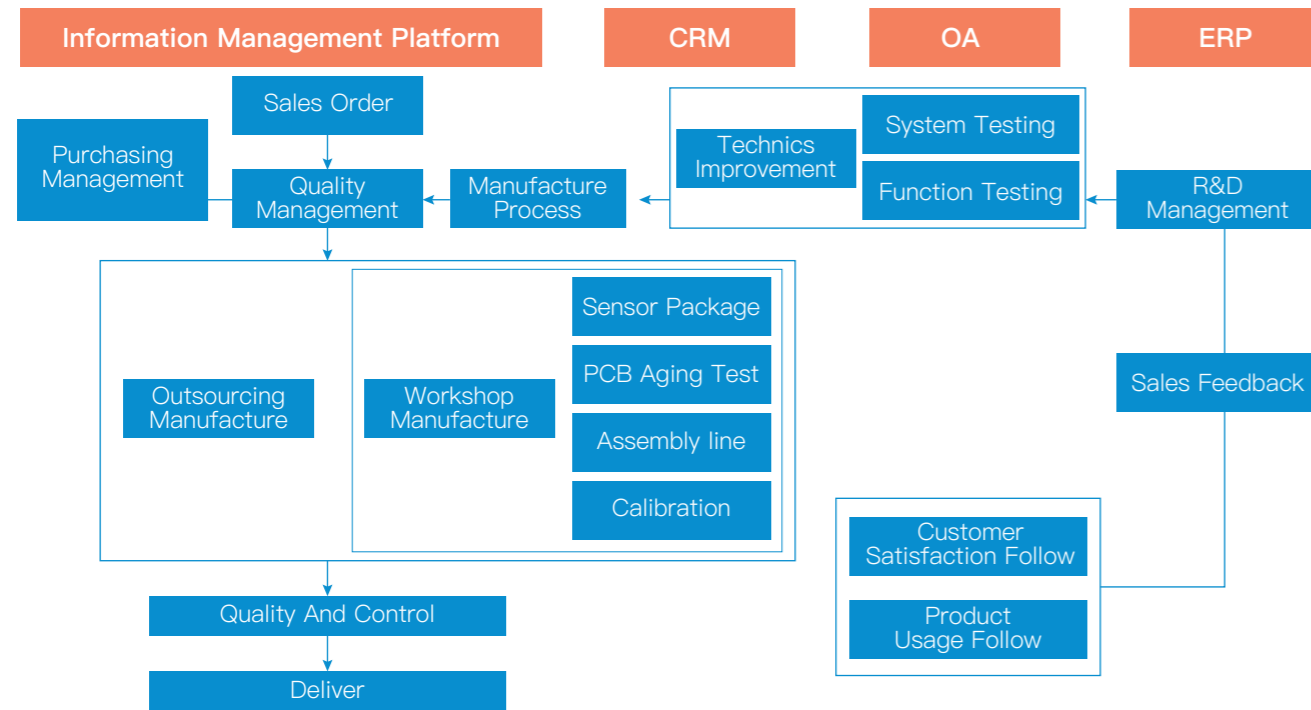

PHM-Product Healthy Management

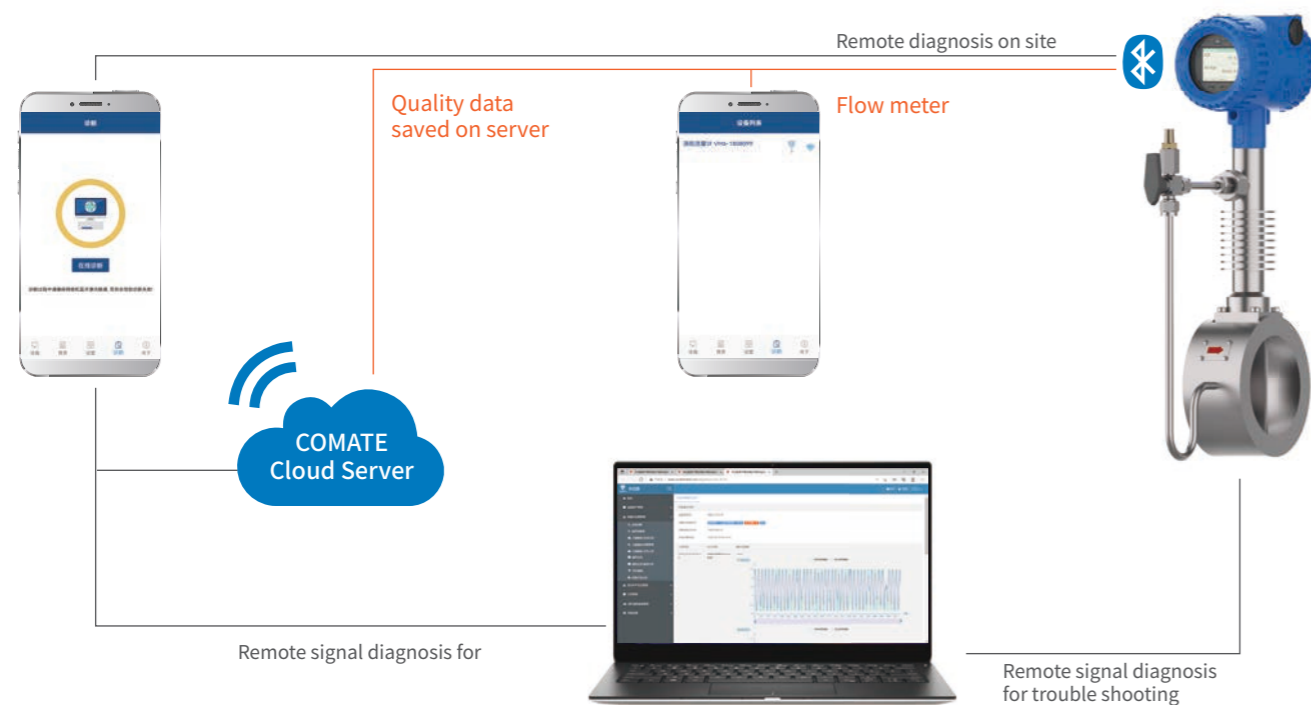

VFM80 Vortex flow meter	01
VFM60 Vortex flow meter	08
VFM55 Vortex flow sensor	14
VFM52 Vortex flow sensor	16
TGF600 Thermal mass flow meter	20
TGF680 Thermal mass flow meter	24
TGF460 Thermal mass flow meter	29
TGF260 Micro flow meter	33
PTF520 Pitot tube flow meter	36
PTF600 Pitot tube flow meter	40
CAE520 Compressed air networking auditing system	44
CAE350S Compressor analyzing system	46
CAE820 Compressed air network auditing system	50
COMATE APP	54
COMATE remote support package	55
Temperature sensor	56
Pressure transmitter	57
Dew point meter	58
KD-9100	60
Localized solution	62
IoT solution	64
DS610 Edge computing server	66
Companel data logger & relay	68
Combox data relay	70

COMATE INTELLIGENT SENSOR

VFM80 VORTEX FLOW METER

Working principle

VFM80 is the best vortex flowmeter utilizing “Karman vortex” theory, which can meet the requirement of measuring the flow rate of various fluids such as gas, steam and liquid.

Special features

- Patent dual-sensor design and optimized signal processing technology to ensure best anti-vibration
- Super low flow measurement down to 2m/s and 1:60 super wide turndown ratio
- Wider measuring range and higher accuracy
- Self-diagnose function plus remote diagnose function, ensure easier trouble-shooting.
- Built-in temperature and pressure compensation and direct mass flow measurement
- 3 channels of 4~20mA output temperature, pressure and flow
- Color LED display and optical touch button operation



Features

Process Fluids	Mostly for liquid, gas ,steam applications and widely used in mechanical manufacturing, electronics, food, metallurgy, pharmaceuticals, textiles
Line Sizes	The wafer and flanged type cover line sizes as below 0.5",0.75",1",1.5",2",2.5",3",4",5",6",8",10",12" (DN15,DN20,DN25,DN40,DN50,DN65,DN80,DN100,DN125,DN150,DN200,DN250,DN300)
Process Connection	Wafer, Flange, ANSI, JIS, DIN standard flanges are optional for flanged connection
Displayer	2" TFT LCD (320*240) display and Optical touch key
Measurable Parameter	Mass flow rate, volume flow meter in standard condition, temperature, pressure, volume flow rate in pipe, velocity
Output Signal	4~20mA(HART@4~20mA) ModBus-RTU RS485
Pressure Allowance	1.6Mpa(232psiG)、2.5Mpa(362psiG)、4.0Mpa(580psiG)、6.3Mpa (913psiG) for option

Specification

Media compatibility	Gas/steam/liquid		
Pipe diameter	DN15~DN300(1/2~12inches)		
Flow velocity range	Gas/Steam(standard)	DN15~DN20	6~70m/s
		DN25~DN32	4~70m/s
		DN40~DN300	2~70m/s
	Steam(extension)	DN40~DN300	2~120m/s
Liquid	0.3~7m/s		
Accuracy	Volume flow	±1%RD	
	Mass flow	±1.0%RD	
	Pressure	±0.5%FS	
	Temperature	±1.0°C	
Repeatability	±0.3%RD		
Power supply	13.5~42V CD		
Output/comm	3x4~20mA+RS485+Pulse+BT RS485+Pulse+BT 1x4~20mA+RS485+Pulse+BT		
Medium temperature	-40°C~250°C (Middle) -40°C~350°C (High)		
Process Pressure	1.6Mpa/2.5Mpa/4.0Mpa/6.3Mpa		
Ambient temperature	-40~85°C		
Process connection	Wafer/flange		
Ingress protection grade	IP65/IP67		
Ex-proof	NEPSI CHINA		
Material	Wet part	304/316SS	
	Transmitter	304/316SS	
	Enclosure	Aluminium	



2" TFT LCD display/optical touch key



VFM80 Standard type without temperature & pressure compensation



VFM80MV Multi-variable type support to 250°C/350°C

Actual flow measuring range

Pipe size	Steam actual flow				liquid actual flow			
	Min flow m ³ /hr	Max flow m ³ /hr	Min flow cu.ft/min	Max flow cu.ft/min	Min flow m ³ /hr	Max flow m ³ /hr	Min flow GPM	Max flow GPM
15mm 0.5 inch	3.8	44.5	2.2	26.2	0.2	4.4	0.8	19.6
20mm 0.75 inch	6.8	79.1	4	46.6	0.3	7.9	1.5	34.8
25mm 1 inch	7.1	123.6	4.2	72.7	0.5	12.4	2.3	54.4
32mm 1.25 inch	11.6	202.5	6.8	119.2	0.9	20.2	3.8	89.2
40mm 1.5 inch	9	316.4	5.3	186.2	1.4	31.6	6.0	139.3
50mm 2 inch	14.1	494.4	8.3	291	2.1	49.4	9.3	217.7
65mm 2.5 inch	23.9	835.5	14	491.7	3.6	83.5	15.8	367.8
80mm 3 inch	36.2	1265.5	21.3	744.9	5.4	126.6	23.9	557.2
100mm 4 inch	56.5	1977.4	33.3	1163.9	8.5	197.7	37.3	870.6
125mm 5 inch	88.3	3089.7	52	1818.5	13.2	309.0	58.3	1360.4
150mm 6 inch	127.1	4449.2	74.8	2618.7	19.1	444.9	84.0	1958.9
200mm 8 inch	226	7909.6	133	4655.4	33.9	791.0	149.3	3482.5
250mm 10 inch	353.1	12358.8	207.8	7274.1	53.0	1235.9	233.2	5441.4
300mm 12 inch	508.5	17796.6	299.3	10474.7	76.3	1779.7	335.8	7835.6

Saturated steam measuring range—Metric unit flow rate in kg/hr

Pipe size	T=112 dgrC P=0.5 barG D=0.8798 kg/m ³		T=121 dgrC P=1 barG D=1.155 kg/m ³		T=134 dgrC P=2 barG D=1.672 kg/m ³		T=144 dgrC P=3 barG D=2.185 kg/m ³		T=159 dgrC P=5 barG D=3.182 kg/m ³	
	Min	Max	Min	Max	Min	Max	Min	Max	Min	Max
	15mm 0.5 inch	3.4	39.1	4.4	51.4	6.4	74.4	8.3	97.2	12.1
20mm 0.75 inch	6.0	69.6	7.8	91.4	11.3	132.2	14.8	172.8	21.6	251.7
25mm 1 inch	6.2	108.7	8.2	142.7	11.8	206.6	15.4	270.0	22.5	393.3
32mm 1.25 inch	10.2	178.1	13.4	233.9	19.3	338.6	25.3	442.4	36.8	644.3
40mm 1.5 inch	8.0	278.4	10.4	365.4	15.1	529.0	19.8	691.3	28.8	1006.7
50mm 2 inch	12.4	434.9	16.3	571.0	23.6	826.6	30.9	1080.2	44.9	1573.0
65mm 2.5 inch	21.0	735.0	27.6	964.9	39.9	1396.9	52.2	1825.5	76.0	2658.4
80mm 3 inch	31.8	1113.4	41.8	1461.7	60.5	2116.0	79.0	2765.2	115.1	4026.9
100mm 4 inch	49.7	1739.7	65.3	2283.9	94.5	3306.2	123.4	4320.6	179.8	6292.1
125mm 5 inch	77.7	2718.3	102.0	3568.6	147.6	5166.0	192.9	6751.0	280.9	9831.4
150mm 6 inch	111.8	3914.4	146.8	5138.8	212.5	7439.0	277.8	9721.4	404.5	14157.2
200mm 8 inch	198.8	6958.9	261.0	9135.6	377.9	13224.9	493.8	17282.5	719.1	25168.4
250mm 10 inch	310.7	10873.2	407.8	14274.4	590.4	20663.8	771.5	27003.9	1123.6	39325.6
300mm 12 inch	447.4	15657.5	587.3	20555.1	850.2	29755.9	1111.0	38885.6	1618.0	56628.8

Pipe size		T=165 dgrC P=6 barG D=3.671 kg/m ³		T=171 dgrC P=7 barG D=4.218 kg/m ³		T=176 dgrC P=8 barG D=4.723 kg/m ³		T=185 dgrC P=10 barG D=5.752 kg/m ³	
		Min	Max	Min	Max	Min	Max	Min	Max
		15mm	0.5 inch	14.0	163.3	16.1	187.7	18.0	210.1
20mm	0.75 inch	24.9	290.4	28.6	333.6	32.0	373.6	39.0	455.0
25mm	1 inch	25.9	453.7	29.8	521.3	33.4	583.7	40.6	710.9
32mm	1.25 inch	42.5	743.3	48.8	854.1	54.6	956.3	66.6	1164.7
40mm	1.5 inch	33.2	1161.4	38.1	1334.5	42.7	1494.3	52.0	1819.8
50mm	2 inch	51.9	1814.8	59.6	2085.2	66.7	2334.8	81.2	2843.5
65mm	2.5 inch	87.6	3066.9	100.7	3523.9	112.7	3945.8	137.3	4805.5
80mm	3 inch	132.7	4645.8	152.5	5338.0	170.8	5977.1	208.0	7279.4
100mm	4 inch	207.4	7259.0	238.3	8340.7	266.8	9339.3	325.0	11374.0
125mm	5 inch	324.1	11342.2	372.4	13032.3	416.9	14592.6	507.8	17771.9
150mm	6 inch	466.7	16332.8	536.2	18766.5	600.4	21013.3	731.2	25591.5
200mm	8 inch	829.6	29036.2	953.2	33362.7	1067.3	37357.1	1299.9	45496.0
250mm	10 inch	1296.3	45369.0	1489.4	52129.2	1667.7	58370.4	2031.1	71087.6
300mm	12 inch	1866.6	65331.4	2144.7	75066.1	2401.5	84053.4	2924.7	102366.1

Pipe size		T=192 dgrC P=12 barG D=6.671 kg/m ³		T=199 dgrC P=14 barG D=7.706 kg/m ³		T=210 dgrC P=18 barG D=9.593 kg/m ³		T=215 dgrC P=20 barG D=10.57 kg/m ³	
		Min	Max	Min	Max	Min	Max	Min	Max
		15mm	0.5 inch	25.4	296.8	29.4	342.9	36.6	426.8
20mm	0.75 inch	45.2	527.6	52.2	609.5	65.0	758.8	71.7	836.0
25mm	1 inch	47.1	824.5	54.4	952.4	67.7	1185.6	74.6	1306.3
32mm	1.25 inch	77.2	1350.8	89.2	1560.4	111.0	1942.4	122.3	2140.3
40mm	1.5 inch	60.3	2110.6	69.7	2438.1	86.7	3035.1	95.5	3344.2
50mm	2 inch	94.2	3297.8	108.8	3809.5	135.5	4742.3	149.3	5225.3
65mm	2.5 inch	159.2	5573.3	183.9	6438.0	229.0	8014.5	252.3	8830.7
80mm	3 inch	241.2	8442.4	278.6	9752.2	346.9	12140.3	382.2	13376.7
100mm	4 inch	376.9	13191.2	435.4	15237.9	542.0	18969.2	597.2	20901.1
125mm	5 inch	588.9	20611.3	680.3	23809.1	846.8	29639.4	933.1	32658.0
150mm	6 inch	848.0	29680.3	979.6	34285.2	1219.4	42680.7	1343.6	47027.5
200mm	8 inch	1507.6	52765.0	1741.5	60951.4	2167.9	75876.8	2388.7	83604.5
250mm	10 inch	2355.6	82445.3	2721.0	95236.6	3387.4	118557.6	3732.3	130632.1
300mm	12 inch	3392.0	118721.2	3918.3	137140.7	4877.8	170722.9	5374.6	188110.2

Saturated steam measuring range—Imperial unit flow rate in lb/hr

Pipe size		T=233.6 dgrF P=7.3 pisG D=0.0034 lb/ft ³		T=249.8 dgrF P=14.5 pisG D=0.0721 lb/ft ³		T=273.2 dgrF P=29 pisG D=0.1044 lb/ft ³		T=291.2 dgrF P=43.5 pisG D=0.1346 lb/ft ³		T=318.2 dgrF P=72.5 pisG D=0.1986 lb/ft ³	
		Min	Max	Min	Max	Min	Max	Min	Max	Min	Max
		15mm	0.5 inch	7.4	86.3	9.7	113.3	14.1	164.0	18.4	214.3
20mm	0.75 inch	13.2	153.4	17.3	201.4	25.0	291.6	32.7	381.0	47.6	554.9
25mm	1 inch	13.7	239.7	18.0	314.7	26.0	455.6	34.0	595.3	49.5	867.0
32mm	1.25 inch	22.4	392.7	29.5	515.6	42.7	746.4	55.7	975.4	81.2	1420.5
40mm	1.5 inch	17.5	613.7	23.0	805.6	33.3	1166.2	43.5	1524.1	63.4	2219.5
50mm	2 inch	27.4	958.9	36.0	1258.8	52.1	1822.2	68.0	2381.3	99.1	3467.9
65mm	2.5 inch	46.3	1620.5	60.8	2127.3	88.0	3079.6	115.0	4024.5	167.5	5860.8
80mm	3 inch	70.1	2454.7	92.1	3222.5	133.3	4664.9	174.2	6096.2	253.7	8877.9
100mm	4 inch	109.6	3835.4	143.9	5035.1	208.3	7289.0	272.2	9525.3	396.3	13871.7
125mm	5 inch	171.2	5992.8	224.8	7867.4	325.4	11389.0	425.2	14883.3	619.3	21674.5
150mm	6 inch	246.6	8629.7	323.7	11329.1	468.6	16400.2	612.3	21432.0	891.8	31211.3
200mm	8 inch	438.3	15341.7	575.4	20140.5	833.0	29155.8	1088.6	38101.4	1585.3	55486.7
250mm	10 inch	684.9	23971.4	899.1	31469.6	1301.6	45556.0	1701.0	59533.4	2477.1	86698.0
300mm	12 inch	986.3	34518.8	1294.7	45316.2	1874.3	65600.6	2449.4	85728.1	3567.0	124845.2

Pipe size		T=329 dgrF P=87 pisG D=0.2292 lb/ft ³		T=339.8 dgrF P=101.5 pisG D=0.2633 lb/ft ³		T=348.8 dgrF P=116 pisG D=0.2948 lb/ft ³		T=365 dgrF P=145 pisG D=0.3591 lb/ft ³	
		Min	Max	Min	Max	Min	Max	Min	Max
		15mm	0.5 inch	30.9	360.1	35.5	413.7	39.7	463.3
20mm	0.75 inch	54.9	640.1	63.0	735.5	70.6	823.6	86.0	1003.0
25mm	1 inch	57.2	1000.2	65.7	1149.3	73.5	1286.8	89.6	1567.2
32mm	1.25 inch	93.6	1638.8	107.6	1882.9	120.5	2108.4	146.7	2567.7
40mm	1.5 inch	73.2	2560.6	84.1	2942.1	94.1	3294.3	114.6	4012.1
50mm	2 inch	114.3	4000.9	131.3	4597.0	147.1	5147.4	179.1	6268.9
65mm	2.5 inch	193.2	6761.5	222.0	7768.9	248.5	8699.1	302.7	10594.4
80mm	3 inch	292.6	10242.2	336.2	11768.4	376.5	13177.3	458.5	16048.3
100mm	4 inch	457.2	16003.4	525.4	18388.0	588.3	20589.6	716.4	25075.4
125mm	5 inch	714.4	25005.4	820.9	28731.3	919.2	32171.2	1119.4	39180.3
150mm	6 inch	1028.8	36007.7	1182.1	41373.1	1323.6	46326.5	1612.0	56419.7
200mm	8 inch	1829.0	64013.8	2101.5	73552.2	2353.1	82358.2	2865.8	100301.6
250mm	10 inch	2857.8	100021.5	3283.6	114925.3	3676.7	128684.7	4477.8	156721.3
300mm	12 inch	4115.2	144031.0	4728.4	165492.4	5294.5	185306.0	6448.0	225678.6

Pipe size		T=377.6 dgrF P=174 pisG D=0.4165 lb/ft ³		T=390.2 dgrF P=203 pisG D=0.4811 lb/ft ³		T=410 dgrF P=261 pisG D=0.5989 lb/ft ³		T=419 dgrF P=290 pisG D=0.6599 lb/ft ³	
		Min	Max	Min	Max	Min	Max	Min	Max
		15mm	0.5 inch	56.1	654.3	64.8	755.9	80.7	940.9
20mm	0.75 inch	99.7	1163.3	115.2	1343.7	143.4	1672.8	158.0	1843.2
25mm	1 inch	103.9	1817.6	120.0	2099.6	149.4	2613.7	164.6	2879.9
32mm	1.25 inch	170.2	2978.0	196.6	3440.0	244.7	4282.4	269.6	4718.5
40mm	1.5 inch	132.9	4653.1	153.6	5375.0	191.2	6691.2	210.6	7372.7
50mm	2 inch	207.7	7270.4	240.0	8398.4	298.7	10455.0	329.1	11519.8
65mm	2.5 inch	351.1	12287.0	405.5	14193.3	504.8	17668.9	556.2	19468.4
80mm	3 inch	531.8	18612.3	614.3	21500.0	764.7	26764.8	842.6	29490.6
100mm	4 inch	830.9	29081.7	959.8	33593.7	1194.9	41819.9	1316.5	46079.1
125mm	5 inch	1298.3	45440.2	1499.7	52490.2	1867.0	65343.7	2057.1	71998.6
150mm	6 inch	1869.5	65433.9	2159.6	75585.9	2688.4	94094.9	2962.2	103678.0
200mm	8 inch	3323.6	116326.8	3839.3	134374.9	4779.4	167279.8	5266.2	184316.4
250mm	10 inch	5193.2	181760.7	5998.9	209960.7	7467.8	261374.7	8228.4	287994.4
300mm	12 inch	7478.2	261735.4	8638.4	302343.4	10753.7	376379.5	11848.9	414711.9

Saturated steam measuring range—Imperial unit flow rate in lb/hr

The standard model number is usually VFM80MV-2-WC-1-N-N-ML1-M-N-xxx

Mode codes			
1	General model	VFM80-MV Vortex mass flowmeter with integral RTD and pressure sensor	Standard
		VFM80-N Vortex flowmeter without integral RTD and pressure sensor	Option
2	Fluid type	1 Liquid	Option
		2 Gas	Standard
		3 Steam	Option
3	Process connection	WC Wafer with carbon steel flanges up to 16 barG (232 psiG) (DN15 ~ DN300)	Standard
		WF Wafer with stainless steel flanges up to 16 barG (232 psiG) (DN15 ~ DN300)	Option
		D1 Flanged DIN PN16 up to 16 barG (232 psiG) (DN15 ~ DN300)	Option
		D2 Flanged DIN PN25 up to 25 barG (362 psiG) (DN15 ~ DN300)	Option
		D3 Flanged DIN PN40 up to 40 barG (580 psiG) (DN15 ~ DN300)	Option
		D4 Flanged DIN PN63 up to 63 barG (913 psiG) (DN15 ~ DN300)	Option
		C1 Flanged ANSI CL150 up to 16 barG (232 psiG) (0.5 inch ~ 12 inch)	Option
		C2 Flanged ANSI CL300 up to 40 barG (580 psiG) (0.5 inch ~ 12 inch)	Option
		C3 Flanged ANSI CL400 up to 63 barG (913 psiG) (0.5 inch ~ 12 inch)	Option
		J1 JIS 10K up to 16 barG (232 psiG) (DN15 ~ DN300)	Option
		J2 JIS 20K up to 40 barG (580 psiG) (DN15 ~ DN300)	Option
J3 JIS 30K up to 63 barG (913 psiG) (DN15 ~ DN300)	Option		
4	Wetted part material	1 OCr18Ni9 (304)	Standard
		2 316	Option
		Q Other	Option
5	Degreased	N Wet part not degreased	Standard
		D Wet part degreased for Oxygen measurement	Option
6	Medium Temperature	S T≤250°C (wafer or flanged)	Standard
		H T≤350°C (wafer or flanged)	Option
7	Transmitter	ML1 Integral transmitter,multi-variable,Bluetooth,RS485,pulse	Option
		ML2 Integral transmitter,multi-variable,Bluetooth,3x4...20mA,RS485,pulse	Standard
		ML3 Integral transmitter,multi-variable,Bluetooth,HART@1x4...20mA, 2x4...20mA, pluse	Option
		MR1 Remote transmitter(dual display),multi-variable,Bluetooth,RS485,pulse	Option
		MR2 Remote transmitter(dual display),multi-variable,Bluetooth, 3x4...20mA,RS485,pulse	Option
		MR4 Remote transmitter(single display),multi-variable,Bluetooth, 3x4...20mA,RS485,pulse	Option
		MR5 Remote transmitter(single display),multi-variable,Bluetooth,RS485,pulse	Option
		MR6 Remote transmitter(single display),multi-variable,Bluetooth,HART@1 x4...20mA, 2x4 ... 20mA, pluse	Option

7	Transmitter	NL1 Integral transmitter, Bluetooth,RS485,pulse	Option
		NL2 Integral transmitter ,Bluetooth,1x4...20mA,RS485,pulse	Option
		NL3 Integral transmitter ,Bluetooth,3x4...20mA,RS485,pulse	Option
		NL4 Integral transmitter,Bluetooth,HART@1x4 ... 20mA, pluse	Option
		NR1 Remote transmitter(dual display), Bluetooth,RS485,pulse	Option
		NR2 Remote transmitter(dual display), Bluetooth, 1x4...20mA ,RS485,pulse	Option
		NR3 Remote transmitter(dual display), Bluetooth, 3x4...20mA ,RS485,pulse	Option
		NR5 Remote transmitter(single display),Bluetooth,RS485,pulse	Option
		NR6 Remote transmitter(single display),Bluetooth,1x4...20mA,RS485,pulse	Option
		NR7 Remote transmitter(single display),Bluetooth,3x4...20mA,RS485,pulse	Option
		NR8 Remote transmitter(single display),Bluetooth,1x4...20mA,HART,pulse	Option
		8	Cable grinder
N NPT 1/2	Option		
9	Ex-proof	N No Ex-proof	Option
		1 Ex db ia IIC T1...T6 Ga/Gb NEPSI CHINA	Option
10	Pipe size	015 DN15 or 0.5 inch	
		020 DN20 or 0.75 inch	
		025 DN25 or 1 inch	
		032 DN32 or 1.25 inch	
		040 DN40 or 1.5 inch	
		050 DN50 or 2 inch	
		065 DN65 or 2.5 inch	
		080 DN80 or 3 inch	
		100 DN100 or 4 inch	
		125 DN125 or 5 inch	
		150 DN150 or 6 inch	
		200 DN200 or 8 inch	
		250 DN250 or 10 inch	
		300 DN300 or 12 inch	

VFM60 VORTEX FLOW METER

Working principle

VFM60 is a powerful flow meter utilizing “Karman vortex” theory, which can meet the requirement of measuring the flow rate of various fluids such as gas, steam and liquid.

Special features

- Super low flow measurement down to 2m/s
- Unique dual sensor technology excellent in anti-vibration
- Multi-variable flow meter, measures flow rate, temperature, pressure, FAD measurement available
- Bluetooth function optional, can read and set on COMATE APP with and smart phone or Pad
- Self-diagnose function plus remote diagnose function, ensure easier trouble-shooting.
- No mechanical wear part



Features

Process Fluids	Used in liquid, gas, and steam applications. Fluids must be homogeneous and single-phase.
Line Sizes	The wafer and flanged type cover line sizes as below. 0.5", 0.75",1", 1.5", 2", 2.5", 3", 4", 5", 6", 8",10", ,12",14",16" (DN15, DN20, DN25, DN40, DN50, DN65, DN80, DN100, DN125, DN150, DN200, DN250, DN300, DN350, DN400), The insertion type covers DN300~1000.
Process Connection	Flange, wafer, insertion, ANSI, JIS, DIN standard flanges are optional for flanged connection
Displayer	Integral or remote.3 buttons control. 2 lines LCD displayer. 1st line has 5 digits to display mass flow or volume flow or frequency or temperature or pressure 2nd line has 8 digits to displayer total flow A small extra line above 1st line will indicate what parameter being displayed in 1st line.
Measurable Parameter	Standard version: Volume flow rate in pipe. Multi-variable version: Mass flow rate, volume flow rate in standard condition, temperature, pressure, volume flow rate in pipe, velocity.
Output Signal	Pulse, high level ≥ 5V, low level < 1V, 50% duty ratio 4~20mA (HART@4~20mA) ModBus-RTU RS485
Pressure Allowance	1.6MPa (232 psiG)、2.5MPa (362 psiG)、4.0MPa (580 psiG)、6.3Mpa (913 psiG) for option

Measurement range

Medium	Min Velocity	Max Velocity
Gas/Steam	6m/s for DN15、DN20 (19.7 ft/s) for 0.5" and 0.75" 4m/s, DN25、DN32 (13.1 ft/s) for 1" and 1.25" 2m/s, DN40 ~ DN300 (6.7 ft/s) for 1.5" ~ 12"	60m/s (196.9 ft/s)
Liquid	0.3m/s (1 ft/s)	6m/s (19.69 ft/s)



VFM60N Standard type vortex meter without temperature & pressure compensation

Specification

Process connection	Flange Wafer	DN15-DN400 or 0.5 inch to 16 inch DN15-DN300 or 0.5 inch to 12 inch
Medium temperature	Standard Medium High	-40 ~ 150 °C or -40 ~ 302 °F -40 ~ 250 °C or -40 ~ 482 °F -40 ~ 350 °C or -40 ~ 662 °F
Power supply	4~20mA 2 wire system VFM60MV with 4~20mA(2 wire) Modbus RTU	13.5 ~ 42V 15.5 ~ 42V Current Iq < 9mA 13.4 ~ 42V
Reynolds and accuracy	Actual flow	±1.0% RD
	Mass flow/ Standard flow	+1.0% RD
	Pressure	+0.5%FS
Turndown ratio	Gas/Steam	1:30
	Liquid	1:20
	Temperature	+1.0°C
Repeatability	Volume flow	±0.3%
	Mass flow	±0.3%
	Temperature	±0.05 °C
	Pressure	±0.05%FS



VFM60MV Multi-variable Vortex Meter standard type support up to 150 °C

Upstream/Downstream requires	15 x D / 5 x D Details please check in manual
Viscosity allowance	DN15 or 0.5 inch ≤ 4mPas DN25 or 1 inch ≤ 5mPas DN40-DN300 or 1.5-12 inch ≤ 7mPas
Anti-vibration (both punch and fixed freq)	0.5g
Display	LCD displayer
Saturated /superheated steam measurement	Support
Natural gas/Biogas, ect	Support
Communication	HART(V5、 V7)/ Modbus-RTU/ Pulse
Explosive proof	Ex db ia IIC T1...T6 Ga/Gb



VFM60MV Multi-variable Vortex Meter high temperature support up to 250°C/350°C

Actual flow measuring range

Pipe size		Steam/gas actual flow				liquid actual flow			
		Min flow m ³ /hr	Max flow m ³ /hr	Min flow cu.ft/min	Max flow cu.ft/min	Min flow m ³ /hr	Max flow m ³ /hr	Min flow GPM	Max flow GPM
15mm	0.5 inch	3.8	38.1	2.2	22.4	0.2	3.8	0.8	16.8
20mm	0.75 inch	6.8	67.8	4	39.9	0.3	6.8	1.5	29.8
25mm	1 inch	7.1	105.9	4.2	62.3	0.5	10.6	2.3	46.6
32mm	1.25 inch	11.6	173.6	6.8	102.2	0.9	17.4	3.8	76.4
40mm	1.5 inch	9	271.2	5.3	159.6	1.4	27.1	6.0	119.4
50mm	2 inch	14.1	423.7	8.3	249.4	2.1	42.4	9.3	186.6
65mm	2.5 inch	23.9	716.1	14	421.5	3.6	71.6	15.8	315.3
80mm	3 inch	36.2	1084.7	21.3	638.5	5.4	108.5	23.9	477.6
100mm	4 inch	56.5	1694.9	33.3	997.6	8.5	169.5	37.3	746.2
125mm	5 inch	88.3	2648.3	52	1558.7	13.2	264.8	58.3	1166.0
150mm	6 inch	127.1	3813.6	74.8	2244.6	19.1	381.4	84.0	1679.1
200mm	8 inch	226	6779.7	133	3990.4	33.9	678.0	149.3	2985.0
250mm	10 inch	353.1	10593.2	207.8	6234.9	53.0	1059.3	233.2	4664.1
300mm	12 inch	508.5	15254.2	299.3	8978.3	76.3	1525.4	335.8	6716.2

Saturated steam measuring range—Metric unit flow rate in kg/hr

Pipe size		T=121 dgrC P=1 barG D=1.155 kg/m ³		T=144 dgrC P=3 barG D=2.185 kg/m ³		T=159 dgrC P=5 barG D=3.182 kg/m ³		T=165 dgrC P=6 barG D=3.671 kg/m ³		T=171 dgrC P=7 barG D=4.218 kg/m ³	
		Min	Max	Min	Max	Min	Max	Min	Max	Min	Max
		15mm	0.5 inch	4.4	44.0	8.3	83.3	12.1	121.3	14	140.0
20mm	0.75 inch	7.8	78.3	14.8	148.1	21.6	215.7	24.9	248.9	28.6	286.0
25mm	1 inch	8.2	122.4	15.4	231.5	22.5	337.1	25.9	388.9	29.8	446.8
32mm	1.25 inch	13.4	200.5	25.3	379.2	36.8	552.3	42.5	637.1	48.8	732.1
40mm	1.5 inch	10.4	313.2	19.8	592.5	28.8	862.9	33.2	995.5	38.1	1143.9
50mm	2 inch	16.3	489.4	30.9	925.8	44.9	1348.3	51.9	1555.5	59.6	1787.3
65mm	2.5 inch	27.6	827.1	52.2	1564.7	76	2278.6	87.6	2628.8	100.7	3020.5
80mm	3 inch	41.8	1252.9	79	2370.2	115.1	3451.7	132.7	3982.1	152.5	4575.5
100mm	4 inch	65.3	1957.6	123.4	3703.4	179.8	5393.2	207.4	6222.0	238.3	7149.2
125mm	5 inch	102	3058.8	192.9	5786.5	280.9	8426.9	324.1	9721.9	372.4	11170.6
150mm	6 inch	146.8	4404.7	277.8	8332.6	404.5	12134.7	466.7	13999.6	536.2	16085.6
200mm	8 inch	261	7830.5	493.8	14813.6	719.1	21572.9	829.6	24888.1	953.2	28596.6
250mm	10 inch	407.8	12235.2	771.5	23146.2	1123.6	33707.6	1296.3	38887.7	1489.4	44682.2
300mm	12 inch	587.3	17618.6	1111	33330.5	1618	48539.0	1866.6	55998.3	2144.7	64342.4

Pipe size		T=176 dgrC P=8 barG D=4.723 kg/m ³		T=185 dgrC P=10 barG D=5.752 kg/m ³		T=192 dgrC P=12 barG D=6.671 kg/m ³		T=199 dgrC P=14 barG D=7.706 kg/m ³		T=215 dgrC P=20 barG D=10.57 kg/m ³	
		Min	Max	Min	Max	Min	Max	Min	Max	Min	Max
		15mm	0.5 inch	18	180.1	21.9	219.4	25.4	254.4	29.4	293.9
20mm	0.75 inch	32	320.2	39	390.0	45.2	452.3	52.2	522.4	71.7	716.6
25mm	1 inch	33.4	500.3	40.6	609.3	47.1	706.7	54.4	816.3	74.6	1119.7
32mm	1.25 inch	54.6	819.7	66.6	998.3	77.2	1157.8	89.2	1337.4	122.3	1834.5
40mm	1.5 inch	42.7	1280.8	52	1559.9	60.3	1809.1	69.7	2089.8	95.5	2866.4
50mm	2 inch	66.7	2001.3	81.2	2437.3	94.2	2826.7	108.8	3265.3	149.3	4478.8
65mm	2.5 inch	112.7	3382.1	137.3	4119.0	159.2	4777.1	183.9	5518.3	252.3	7569.2
80mm	3 inch	170.8	5123.3	208	6239.5	241.2	7236.3	278.6	8359.1	382.2	11465.8
100mm	4 inch	266.8	8005.1	325	9749.2	376.9	11306.8	435.4	13061.0	597.2	17915.3
125mm	5 inch	416.9	12507.9	507.8	15233.1	588.9	17666.8	680.3	20407.8	933.1	27992.6
150mm	6 inch	600.4	18011.4	731.2	21935.6	848	25440.3	979.6	29387.3	1343.6	40309.3
200mm	8 inch	1067.3	32020.3	1299.9	38996.6	1507.6	45227.1	1741.5	52244.1	2388.7	71661.0
250mm	10 inch	1667.7	50031.8	2031.1	60932.2	2355.6	70667.4	2721	81631.4	3732.3	111970.3
300mm	12 inch	2401.5	72045.8	2924.7	87742.4	3392	101761.0	3918.3	117549.2	5374.6	161237.3

saturated steam measuring range—Imperial unit flow rate in lb/hr

Pipe size		T=249.8 dgrF P=14.5 pisG D=0.0721 lb/ft ³		T=291.2 dgrF P=43.5 pisG D=0.1364 lb/ft ³		T=318.2 dgrF P=72.5 pisG D=0.1986 lb/ft ³		T=329 dgrF P=87 pisG D=0.2292 lb/ft ³		T=339.8 dgrF P=101.5 pisG D=0.2633 lb/ft ³	
		Min	Max	Min	Max	Min	Max	Min	Max	Min	Max
		15mm	0.5 inch	9.7	97.1	18.4	183.7	26.8	267.5	30.9	308.6
20mm	0.75 inch	17.3	172.6	32.7	326.6	47.6	475.6	54.9	548.7	63	630.4
25mm	1 inch	18	269.7	34	510.3	49.5	743.1	57.2	857.3	65.7	985.1
32mm	1.25 inch	29.5	441.9	55.7	836.1	81.2	1217.5	93.6	1404.6	107.6	1613.9
40mm	1.5 inch	23	690.5	43.5	1306.3	63.4	1902.4	73.2	2194.8	84.1	2521.8
50mm	2 inch	36	1079.0	68	2041.1	99.1	2972.5	114.3	3429.3	131.3	3940.3
65mm	2.5 inch	60.8	1823.4	115	3449.5	167.5	5023.5	193.2	5795.5	222	6659.1
80mm	3 inch	92.1	2762.1	174.2	5225.3	253.7	7609.6	292.6	8779.0	336.2	10087.2
100mm	4 inch	143.9	4315.8	272.2	8164.6	396.3	11890.0	457.2	13717.2	525.4	15761.2
125mm	5 inch	224.8	6743.5	425.2	12757.2	619.3	18578.1	714.4	21433.2	820.9	24626.8
150mm	6 inch	323.7	9710.6	612.3	18370.3	891.8	26752.5	1028.8	30863.8	1182.1	35462.7
200mm	8 inch	575.4	17263.3	1088.6	32658.3	1585.3	47560.1	1829	54868.9	2101.5	63044.7
250mm	10 inch	899.1	26973.9	1701	51028.6	2477.1	74312.6	2857.8	85732.7	3283.6	98507.4
300mm	12 inch	1294.7	38842.5	2449.4	73481.2	3567	107010.1	4115.2	123455.1	4728.4	141850.6

Pipe size		T=348.8 dgrF P=116 pisG D=0.2948 lb/ft ³		T=365 dgrF P=145 pisG D=0.3591 lb/ft ³		T=377.6 dgrF P=174 pisG D=0.4165 lb/ft ³		T=390.2 dgrF P=203 pisG D=0.4811 lb/ft ³		T=419 dgrF P=290 pisG D=0.6599 lb/ft ³	
		Min	Max	Min	Max	Min	Max	Min	Max	Min	Max
		15mm	0.5 inch	39.7	397.1	48.4	483.6	56.1	560.9	64.8	647.9
20mm	0.75 inch	70.6	705.9	86	859.7	99.7	997.1	115.2	1151.8	158	1579.9
25mm	1 inch	73.5	1103.0	89.6	1343.3	103.9	1557.9	120	1799.7	164.6	2468.5
32mm	1.25 inch	120.5	1807.2	146.7	2200.9	170.2	2552.5	196.6	2948.6	269.6	4044.4
40mm	1.5 inch	94.1	2823.7	114.6	3438.9	132.9	3988.3	153.6	4607.1	210.6	6319.4
50mm	2 inch	147.1	4412.0	179.1	5373.3	207.7	6231.8	240	7198.7	329.1	9874.1
65mm	2.5 inch	248.5	7456.4	302.7	9080.9	351.1	10531.7	405.5	12165.7	556.2	16687.2
80mm	3 inch	376.5	11294.8	458.5	13755.6	531.8	15953.4	614.3	18428.6	842.6	25277.7
100mm	4 inch	588.3	17648.2	716.4	21493.2	830.9	24927.2	959.8	28794.6	1316.5	39496.4
125mm	5 inch	919.2	27575.3	1119.4	33583.1	1298.3	38948.7	1499.7	44991.6	2057.1	61713.1
150mm	6 inch	1323.6	39708.4	1612	48359.7	1869.5	56086.2	2159.6	64787.9	2962.2	88866.8
200mm	8 inch	2353.1	70592.8	2865.8	85972.8	3323.6	99708.7	3839.3	115178.5	5266.2	157985.5
250mm	10 inch	3676.7	110301.2	4477.8	134332.5	5193.2	155794.9	5998.9	179966.3	8228.4	246852.3
300mm	12 inch	5294.5	158833.7	6448	193438.8	7478.2	224344.6	8638.4	259151.5	11848.9	355467.4

saturated steam measuring range—Imperial unit flow rate in lb/hr

The standard model number is usually VFM60MV-2-WC-1-N-N-ML1-M-N-XXX,
Please reference to the table below for what the model codes stand for.

Mode codes			
1 General model	VFM60-MV	Vortex mass flowmeter with integral RTD and pressure sensor	Standard
	VFM60-N	Vortex flowmeter without integral RTD and pressure sensor	Option
2 Fluid type	1	Liquid	Option
	2	Gas	Standard
	3	Steam	Option
3 Process connection	WC	Wafer with carbon steel flanges up to 16 barG (232 psiG) (DN15 ~ DN300)	Standard
	WF	Wafer with stainless steel flanges up to 16 barG (232 psiG) (DN15 ~ DN300)	Option
	D1	Flanged DIN PN16 up to 16 barG (232 psiG) (DN15 ~ DN400)	Option
	D2	Flanged DIN PN25 up to 25 barG (362 psiG) (DN15 ~ DN400)	Option
	D3	Flanged DIN PN40 up to 40 barG (580 psiG) (DN15 ~ DN400)	Option
	D4	Flanged DIN PN63 up to 63 barG (913 psiG) (DN15 ~ DN400)	Option
	C1	Flanged ANSI CL150 up to 16 barG (232 psiG) (0.5 inch ~ 16 inch)	Option
	C2	Flanged ANSI CL300 up to 40 barG (580 psiG) (0.5 inch ~ 16 inch)	Option
	J1	JIS 10K up to 16 barG (232 psiG) (DN15 ~ DN400)	Option
	J2	JIS 20K up to 40 barG (580 psiG) (DN15 ~ DN400)	Option
4 Wetted part material	1	OCr18Ni9 (304)	Standard
	2	316	Option
	Q	Other	Standard
5 Degreased	N	Wet part not degreased	Option
	D	Wet part degreased for Oxygen measurement	Standard
6 Medium Temperature	N	T≤150°C	Option
	S	T≤250°C (wafer or flanged)	Option
	H	T≤350°C (wafer or flanged)	Standard
7 Transmitter	ML1	Integral transmitter, multi-variable, bluetooth, RS485, pulse,	Option
	ML2	Integral transmitter, multi-variable, bluetooth, RS485, pulse, 4 wire 4~20mA	Option
	ML3	Integral transmitter, multi-variable, bluetooth, pulse, 4 wire HART@4~20mA	Option
	ML4	Integral transmitter, multi-variable, pulse, 2 wire HART@4~20mA	Option

7 Transmitter	MR1	Remote transmitter (dual display), multi-variable, bluetooth, RS485, pulse	Option
	MR2	Remote transmitter (dual display), multi-variable, bluetooth, RS485, pulse, 4 wire 4~20mA	Option
	ME5	Remote transmitter(single display),multi-variable,bluetooth,RS485	Option
	ME6	Remote transmitter(single display),multi-variable,bluetooth,RS485,pulse,4 wire 4~20mA	Option
	ME7	Remote transmitter(single display), multi-variable, pulse, 2 wire HART@4~20mA	Option
	ME8	Remote transmitter(single display), multi-variable, bluetooth,pulse, 4 wire HART@4~20mA	Option
	NL1	Integral transmitter, bluetooth, RS485, pulse,	Option
	NL2	Integral transmitter, bluetooth, RS485, pulse, 4 wire 4~20mA	Option
8 Cable grinder	NL3	Integral transmitter, bluetooth, pulse, 4 wire HART@4~20mA	Option
	NL4	Integral transmitter, pulse, 2 wire HART@4~20mA	Option
	NR1	Remote transmitter (dual display), bluetooth, RS485, pulse,	Option
	NR2	Remote transmitter (dual display), bluetooth, RS485, pulse, 4 wire 4~20mA	Option
	NR3	Remote transmitter (single display), bluetooth, pulse, 4 wire HART@4~20mA	Option
	NR4	Remote transmitter (single display), pulse, 2 wire HART@4~20mA	Option
	M	M20x1.5	Standard
	N	NPT 1/2	Option
9 Ex-proof	N	No Ex-proof	Standard
	1	Ex db ia IIC T1...T6 Ga/Gb	Option
10 Pipe size	015	DN15 or 0.5 inch	
	020	DN20 or 0.75 inch	
	025	DN25 or 1 inch	
	032	DN32 or 1.25 inch	
	040	DN40 or 1.5 inch	
	050	DN50 or 2 inch	
	065	DN65 or 2.5 inch	
	080	DN80 or 3 inch	
	100	DN100 or 4 inch	
	125	DN125 or 5 inch	
150	DN150 or 6 inch		
200	DN200 or 8 inch		
250	DN250 or 10 inch		
300	DN300 or 12 inch		
350	DN350 or 14 inch		
400	DN400 or 16 inch		

VFM55 VORTEX FLOW SENSOR

Working principle

VFM55 Vortex flow sensor based on “Karman vortex” theory, and designed for air, gas in small pipeline measurement.



Special features

- Wet/dry air measurement
- DN15, DN25 small pipe line measurement
- Combines temperature, pressure, flow and standard flow measurement
- Bluetooth function optional, can read and set on COMATE APP with and smart phone or Pad
- Battery power supply and also have 24VDC
- User-friendly operating interface



Specification

Fluid Compatibility	air, non-corrosive gas	Power supply	battery or 24 VDC
Pipe Diameter	DN15(Convert to DN8, DN10) DN25(Convert to DN20)	Communication	pulse, RS485, Bluetooth
Measure Range	16~300L/min(volume flow)	Data Display	temperature, pressure, standard flow
Accuracy after compensation	1.5% of reading or 3.0% of reading	Housing	PPS
Fluid Temperature	-40~+80°C	Wetted Parts Material	Aluminium-alloy
Pressure Rating	1.0Mpa / 1.6Mpa	Ingress Protection	IP65

Pipe size (mm)	Pipe size (inch)	4barG		5barG		6barG		7barG	
		Min NL/min	Max NL/min	Min NL/min	Max NL/min	Min NL/min	Max NL/min	Min NL/min	Max NL/min
15mm~25mm	1/2"~1"	80	1500	96	1800	112	2100	128	2400

Mode number

The Standard model number is usually VFM55MV-A-G-1-1-XXX
Pls reference to the table below for what the model codes stands for

Mode codes				
1	Mode	VFM55	Basic mode	
2	Output	A	Pulse,RS485,Bluetooth	Standard
		B	pulse, 4~20mA, RS485,Bluetooth	Optional
3	Connection	G	G thread male	Standard
4	Power Supply	1	Battery	Optional
		N	24VDC	Standard
5	Pressure	1	1.0Mpa	Standard
		2	1.6Mpa	Optional
6	Pipe size	8	DN8(1/4")	Optional
		10	DN10(3/8")	Optional
		15	DN15(1/2")	Standard
		20	DN20(3/4")	Optional
		25	DN25(1")	Optional



VFM52 VORTEX FLOW SENSOR

Working principle

VFM52 Vortex flow sensor is designed based on “Karman Vortex street” principle,It is a compact, economical model product.

Special features

- Can handle vibration interference base on its dual-sensor design
- 1:30 super wide turn down,measurement range down to 10L/min
- 1.5 %RD accuracy even at minus pressure
- Use special anti-corrosive material for corrosive fluid measurement
- No moving part, Bluetooth remote diagnosis available
- For gas flow measurement. Economical solution for massive installation



Specification

Pipe Size	DN15(DN8~DN25 available connector)	Process connection	G1/2 thread
Measurement range	For gas/air: 20~300L/min (actual flow)	Environment temperature	-20°C~60°C
Accuracy	Standard: 3%RD High accuracy model: 1.5% RD	Environment humidity	5%~99%
Repeatability	0.3%	Protection	IP65
Power supply	24V DC	Ex-proof	Ex ia II B T4 Ga
Output/Comm	Pulse(Default is 2.5L/pulse ,can set through BT)	Ex cert No.	CNEx22.1867
Medium temperature	-40°C~85°C	Material	Shedder bar:PPS Shell:PPS
Pressure rating	1.0Mpa	Connection	G thread

Safety Barrier Specification

Ex-proof	[Ex ia Ga] II B Um:230V, Uo:5.88V, Po:0.27W, Io:180mA
Voltage	12~32VDC
Working temperature	-20°C~60°C

Typical application

- Compressed air consumption
- Gasoline vapour recovery
- Other non-corrosive gas in small pipe such as CO₂, Argon

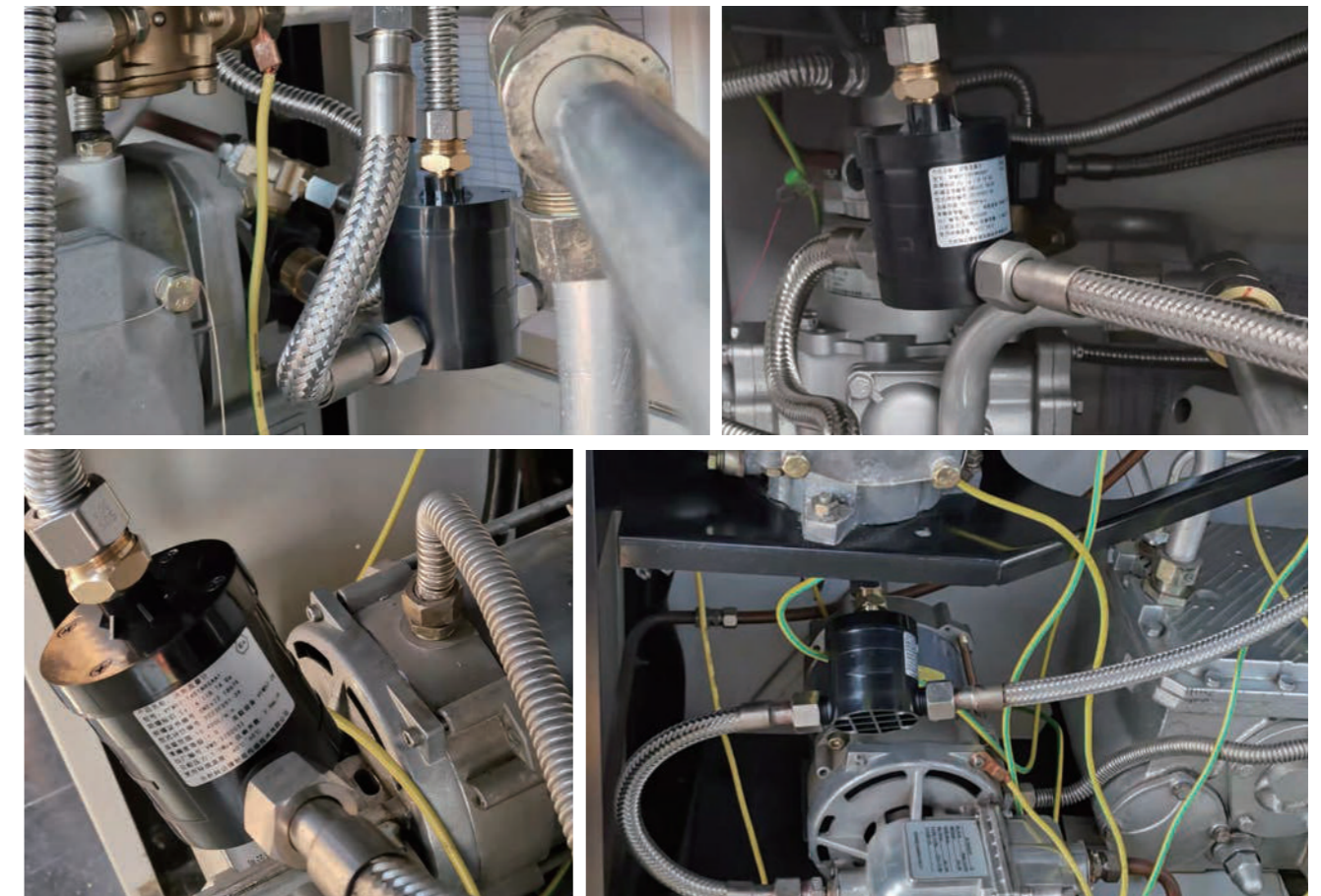

Dimension

Dimension of flow meter

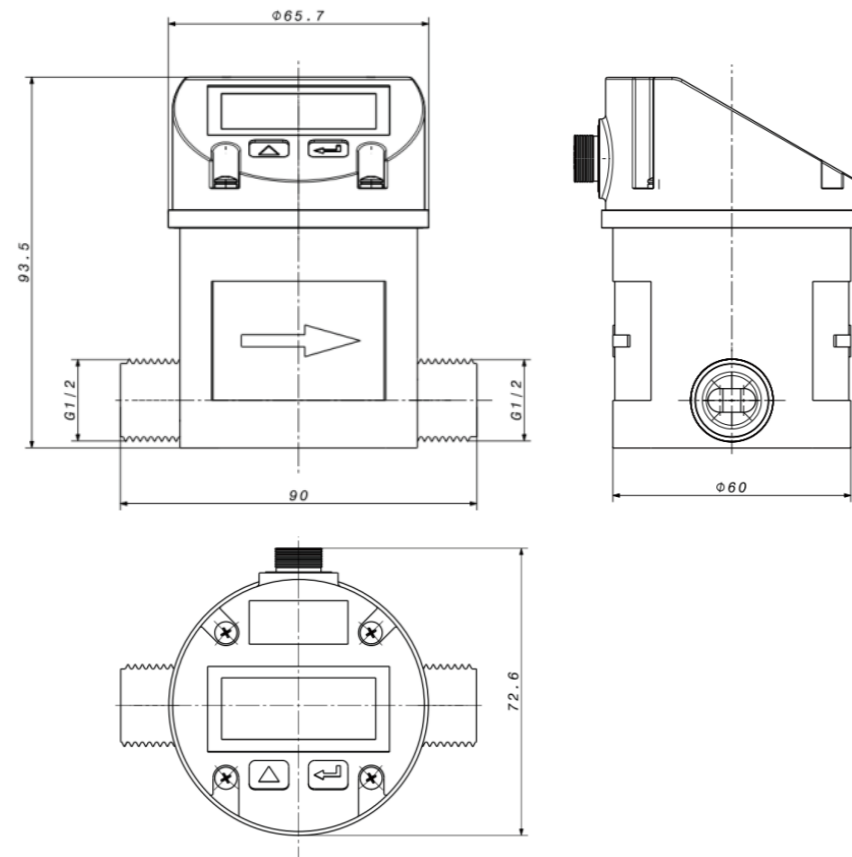

Model Number

The Standard model number is usually VFM52-2-A-G-1-1-XXX
 Pls reference to the table below for what the model codes stands for

Mode codes

1	Mode	VFM52MV-1	Frequency,RS485,Bluetooth for gas only	Standard
		VFM52MV-2	Frequency,RS485,4~20mA,Bluetooth for gas only	Optional
2	Connection	G	G thread ,male	Standard
3	Accuracy	1	1.5% RD (actual flow accuracy)	Optional
		2	3% RD (actual flow accuracy)	Standard
4	Power supply	1	24VDC	Standard
5	Output	A	Frequency,RS485,Bluetooth for gas only	Optional
		D	24VDC Power with barrier, pulse output (For EX ia version)	Optional
6	Pipe Size	8	DN8 (1/4")	Optional
		10	DN10 (3/8")	Optional
		15	DN15 (1/2")	Optional
		20	DN20 (3/4")	Optional
		25	DN25 (1")	Optional

TGF600 THERMAL MASS FLOW METER

Working principle

TGF600 Series Thermal Mass Flowmeter measures the gas mass flow base on thermal diffusion theory. It has two filmed RTDs as its sensors, one of which sense the velocity of the gas flow (RH) and the other one will detect the temperature shift of the gas flow (RMG). When the two RTD are in the gas flow ,the RH will be heated while the RMG will sense the temperature changing of the gas flow. More heat will be taken away as the velocity of the gas flow increasing, so the temperature on RH will decline.

Special features

- Direct mass flow or normal flow measurement
- 100:1 turn down ratio in 6 ranges: 0.3~30Nm/s, 0.6Nm/s~60 Nm/s, 0.9~90Nm/s, 1.2~120Nm/s, 1.5~150Nm/s, or 1.8~180Nm/s
- No pressure loss, suitable for pipe in any shape with known sectional area
- For the insertion type, installation and maintenance can be finished on line
- High accuracy data acquisition circuit to ensure outstanding repeatability and accuracy
- High efficiency design of power supply, the total power consumption is only 60mA@24VDC
- 16V~32V wide voltage range input to fit in all electricity environment
- Self-diagnose function plus remote diagnose function, ensure easier trouble-shooting
- Ex-proof version optional
- Bluetooth communication for reading, setting and diagnosis and COMMATE APP
- No mechanical wear part



Specification

Media Compatibility	Air, Nitrogen, O ₂ , CO ₂ , Argon, CH ₄ , Natural gas, biogas, and almost all dry and clean gas.
Pipe Diameter	Insertion: DN25 ~ 2500mm Inline: DN25 ~ 300mm
Flow Velocity Range	0.3~30Nm/s 0.6~60Nm/s 0.9~90Nm/s 1.2~120Nm/s 1.5~150Nm/s 1.8~180Nm/s
Accuracy	1.5% Reading ± 0.5% Full Scale
Temperature of Medium	Standard: -40 ~ +150°C Middle: -40 ~ +250°C High: -40 ~ +450°C
Pressure of Medium	Insertion: 1.6 MPa Flanged insertion: 6.3 MPa Flanged in-line: 6.3 MPa
Process Connection	NPT 1" insertion with ball valve
Power Supply	AC85~264V or DC16~32V
Response Time	1 second
Output	Frequency and 4~20mA as standard
Communication	RS-485 + Bluetooth as standard , 4~20mA@HART as optional
Date Displayed	Mass flow, Total flow Volume flow in normal condition
Ingress Protection Grade	IP65 (GB China)
Ex-proof	Ex db IIC T1...T6 Gb

Insertion type with ball valve
Install/remove the meter without stopping the flow

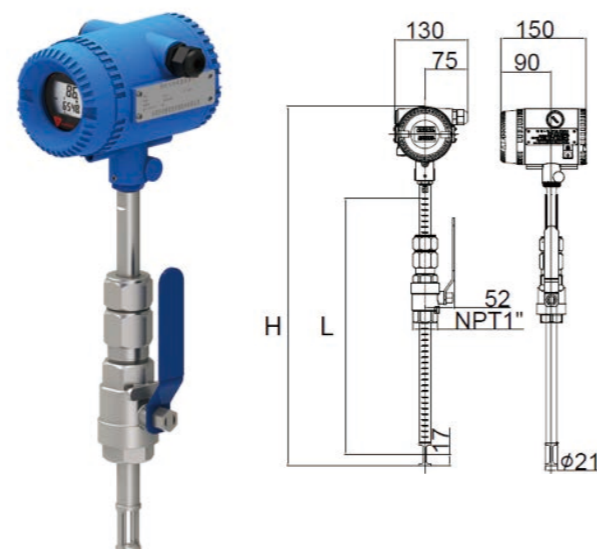

Probe	H	L
290 mm	433.5 mm	255.5 mm
440 mm	583.5 mm	405.5 mm
690 mm	833.5 mm	655.5 mm
1000 mm	1143.5 mm	965.5 mm
1500 mm	1643.6 mm	1465.5 mm

Max pipe size that each probe can adapt to					
Probe length	290mm	440mm	690mm	1000mm	1500mm
T < 50 dgr C	DN150	DN450	DN900	DN1500	DN2500
50 °C < T < 150 °C	/	DN100	DN600	DN1200	DN2200
150 °C < T < 250 °C	/	/	DN400	DN1000	DN2000
250 °C < T < 450 °C	/	/	DN300	DN600	DN1000
T < 122 °F	6"	18"	36"	60"	100"
122 °F < T < 302 °F	/	4"	24"	48"	88"
302 °F < T < 482 °F	/	/	16"	40"	80"
482 °F < T < 842 °F	/	/	12"	24"	40"

Other process connection



Flanged insertion type

For applications with pressure higher than 1.6MPa

Flanged type

For in-line connection, 1.6 ~ 6.3 MPa and different flanged standard available

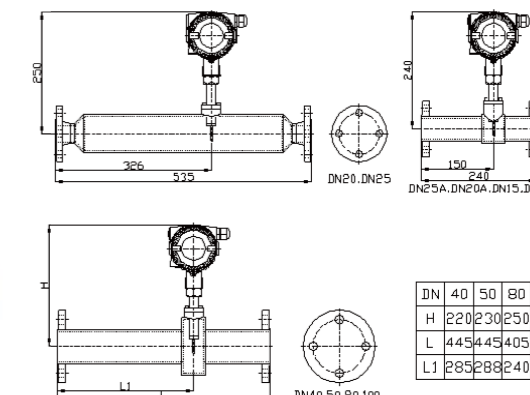

Dimension of Flanged type

thermal mass flow meter

Standard Volume flow rate range in popular sizes

Pipe size (mm)	Pipe size (inch)	Option 1 (0.3~30 Nm/s)		Standard (0.6~60 Nm/s)		Option 2 (0.9~90 Nm/s)		Option 3 (1.2~120 Nm/s)	
		Min flow Nm ³ /hr	Max flow Nm ³ /hr	Min flow Nm ³ /hr	Max flow Nm ³ /hr	Min flow Nm ³ /hr	Max flow Nm ³ /hr	Min flow Nm ³ /hr	Max flow Nm ³ /hr
25 mm	1"	0.53	53	1.05	105.9	1.58	158.8	2.11	211.8
32 mm	1 1/4"	0.87	86.7	1.73	173.5	2.6	260.3	3.47	347.1
40 mm	1 1/2"	1.36	135.6	2.71	271.1	4.06	406.7	5.42	542.3
50 mm	2"	2.12	211.9	4.23	423.7	6.35	635.5	8.47	847.4
65 mm	2 1/2"	3.58	358.1	7.1	716.1	10.7	1074.1	14.3	1432.2
80 mm	3"	5.42	542.3	10.8	1084.7	16.2	1627.1	21.6	2169.4
100 mm	4"	8.47	847.5	16.9	1694.9	25.4	2542.3	33.8	3389.8
125 mm	5"	13.2	1324.2	26.4	2648.3	39.7	3972.4	52.9	5296.6
150 mm	6"	19.1	1906.8	38.1	3813.5	57.2	5720.3	76.2	7627.1
200 mm	8"	33.9	3389.8	67.7	6779.6	101.6	10169.4	135.5	13559.3
250 mm	10"	53	5296.6	105.9	10593.2	158.8	15889.8	211.8	21186.4
300 mm	12"	76.3	7627.1	152.5	15254.2	228.8	22881.3	305	30508.4

Mode number

The standard model number is usually TGF600-1-2-I2-1-N-T-M-N-1-1-XXXX, Please reference to the table below for what the model codes stand for.

Mode codes				
1	General model	TGF600	Standard	
2	Fluid type	1	Air/nitrogen	Standard
		2	Oxygen (sensor will be degreased)	Option
		3	Other (Please advise gas composition)	Option
3	Measurement range	1	0.3~30 Nm/s	Option
		2	0.6~60 Nm/s	Standard
		3	0.9~90 Nm/s	Option
		4	1.2~120 Nm/s	Option
		5	1.5~150 Nm/s	Option
		6	1.8~180 Nm/s	Option
4	Process connection	I1	Insertion type with 290mm probe	Option
		I2	Insertion type with 440mm probe	Standard
		I3	Insertion type with 690mm probe	Option
		I4	Insertion type with 1000mm probe	Option
		I5	Insertion type with 1500mm probe	Option
		F1	Flanged insertion type up to 25 barG (362 psiG)	Option
		F2	Flanged insertion type up to 40 barG (580 psiG)	Option
		F3	Flanged insertion type up to 63 barG (913 psiG)	Option
		D1	Flanged DIN PN16 up to 16 barG (232 psiG) (DN15~DN300)	Option
		D2	Flanged DIN PN25 up to 25 barG (362 psiG) (DN15~DN300)	Option
		D3	Flanged DIN PN40 up to 40 barG (580 psiG) (DN15~DN300)	Option
		D4	Flanged DIN PN63 up to 63 barG (913 psiG) (DN15~DN300)	Option
		C1	Flanged ANSI CL150 up to 16 barG (232 psiG) (0.5 inch~12 inch)	Option
		C2	Flanged ANSI CL300 up to 40 barG (580 psiG) (0.5 inch~12 inch)	Option
		C3	Flanged ANSI CL400 up to 63 barG (913 psiG) (0.5 inch~12 inch)	Option
5	Wet part material	J1	JIS 10K up to 16 barG (232 psiG) (DN15~DN300)	Option
		J2	JIS 20K up to 40 barG (580 psiG) (DN15~DN300)	Option
		J3	JIS 30K up to 63 barG (913 psiG) (DN15~DN300)	Option
5	Wet part material	1	316ss sensor with 304ss wet parts	Standard
		2	316ss sensor with 316ss wet parts	Option

6	Medium temp range	N	< 150°C	Standard
		Q	< 250°C	Option
		H	< 450°C (please select remote display also)	Option
7	Transmitter	T	Integral	Standard
		R	Remote	Option
8	Cable grinder	M	M20 x 1.5	Standard
		N	NPT 1/2	Option
9	Ex-proof	N	No Ex-proof	Standard
		1	Ex db IIC T1...T6 Gb	Option
10	Transmitter	1	pulse/frequency + 4~20mA + RS485 + Bluetooth	Standard
		2	pulse/frequency + 4~20mA@HART + Bluetooth	Option
11	Power supply	1	13.5~42VDC	Standard
		2	13.5~42VDC with 85~265VAC 50/60Hz power converter	Option
12	Pipe size	xxxx	please use 4 digit pipe size, such as DN50=0050, DN300=0300 (unit is mm)	xxxx



TGF680 THERMAL MASS FLOW METER

Working principle

TGF680 Series Thermal Mass Flowmeter measures the gas mass flow base on thermal diffusion theory. It has two filmed RTDs as its sensors, one of which sense the velocity of the gas flow (RH) and the other one will detect the temperature shift of the gas flow (RMG). When the two RTD are in the gas flow ,the RH will be heated while the RMG will sense the temperature changing of the gas flow. More heat will be taken away as the velocity of the gas flow increasing, so the temperature on RH will decline.

Special features

- Direct mass flow or normal flow measurement
- 100:1 turn down ratio in 7 ranges: 0.3~30Nm/s, 0.6Nm/s~60 Nm/s, 0.9~90Nm/s, 1.2~120Nm/s, 1.5~150Nm/s, 1.8~180Nm/s or 0.9 ~ 240 Nm/s
- No pressure loss, suitable for pipe in any shape with known sectional area
- For the insertion type, installation and maintenance can be finished on line
- High accuracy data acquisition circuit to ensure outstanding repeatability and accuracy
- High efficiency design of power supply, the total power consumption is only 60mA@24VDC
- 13.5V~32V wide voltage range input to fit in all electricity environment
- Self-diagnose function plus remote diagnose function, ensure easier trouble-shooting
- Ex-proof version optional
- Bluetooth communication for reading, setting and diagnosis and COMATE APP



Specification

Media Compatibility	Air, Nitrogen, O ₂ , CO ₂ , Argon, CH ₄ , Natural gas, biogas, and almost all dry and clean gas	
Pipe diameter	Insertion: DN25 ~ DN600 Inline: DN25 ~ DN300	
Flow velocity range	0.3 ~ 30Nm/s 0.6 ~ 60Nm/s 0.9 ~ 90Nm/s	1.2 ~ 120Nm/s 1.5 ~ 150Nm/s 1.8 ~ 180Nm/s 0.9 ~ 240Nm/s
Accuracy	1.5% RD ± 0.5% FS	
Temperature of medium	Standard: -40 ~ +150°C Middle: -40 ~ +250°C High: -40 ~ +450°C	
Pressure of medium	Insertion: 1.6 MPa Flanged insertion: 6.3 MPa Flanged in-line: 6.3 MPa	
Power supply	AC85~264V or DC16~32V	
Response time	1 second	
Output	Frequency and 4~20mA as standard	
Communication	RS485 + 3x4~20mA , 4~20mA@HART + 2x4~20mA	
Date displayed	Mass flow, Total flow Volume flow in normal condition	
Ingress protection grade	IP65 (GB China)	
Ex-proof	NEPSI EX d II c T3 Gb	

Insertion type with ball valve
Install/remove the meter without stopping the flow

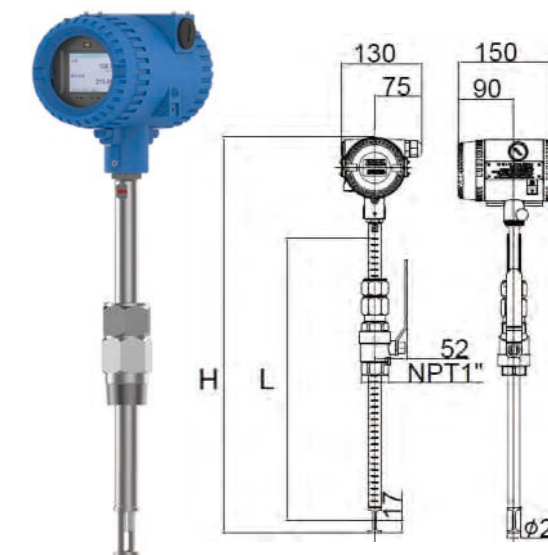

Probe	H	L
290 mm	433.5 mm	255.5 mm
440 mm	583.5 mm	405.5 mm
690 mm	833.5 mm	655.5 mm
1000 mm	1143.5 mm	965.5 mm
1500 mm	1643.6 mm	1465.5 mm

Max pipe size that each probe can adapt to					
Probe length	290mm	440mm	690mm	1000mm	1500mm
T < 50 dgr C	DN150	DN450	DN900	DN1500	DN2500
50 °C < T < 150 °C	/	DN100	DN600	DN1200	DN2200
150 °C < T < 250 °C	/	/	DN400	DN1000	DN2000
250 °C < T < 450 °C	/	/	DN300	DN600	DN1000
T < 122 °F	6"	18"	36"	60"	100"
122 °F < T < 302 °F	/	4"	24"	48"	88"
302 °F < T < 482 °F	/	/	16"	40"	80"
482 °F < T < 842 °F	/	/	12"	24"	40"

Other process connection

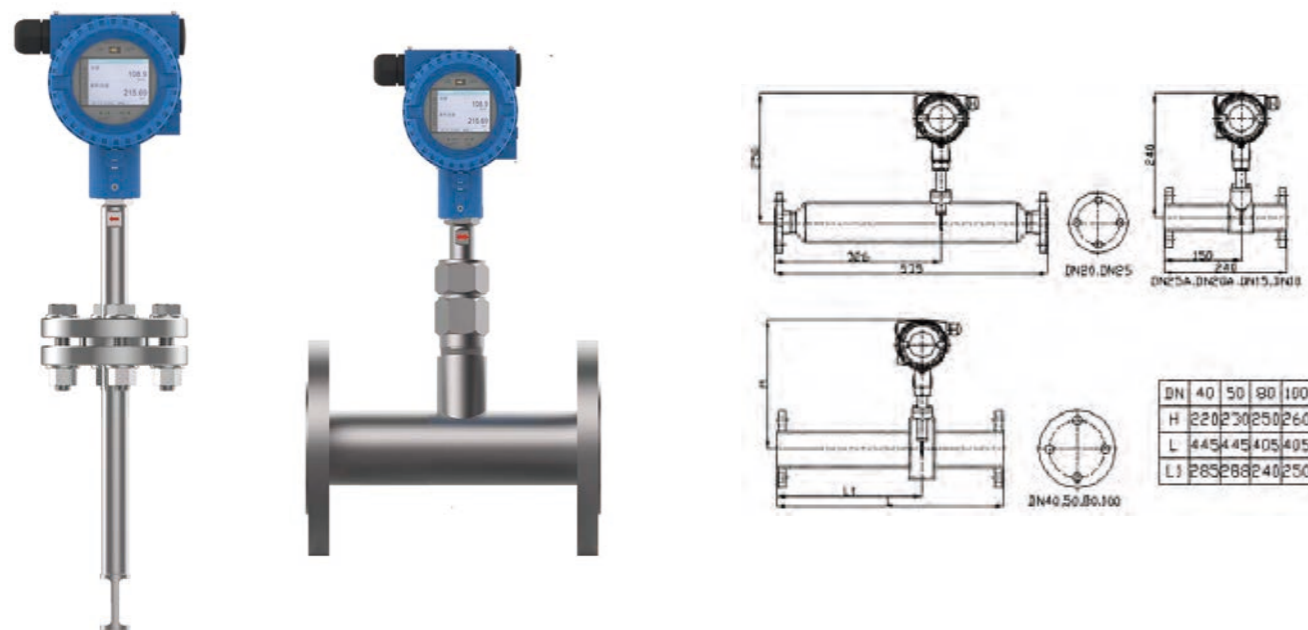

Flanged insertion type

For applications with pressure higher than 1.6MPa

Flanged type

For in-line connection, 1.6 ~ 6.3 MPa and different flanged standard available

Dimension of Flanged type

Thermal mass flow meter

Standard Volume flow rate range in popular sizes

Pipe size (mm)	Pipe size (inch)	Option 1 (0.3~30 Nm/s)		Standard (0.6~60 Nm/s)		Option 2 (0.9~90 Nm/s)		Option 3 (1.2~120 Nm/s)	
		Min flow Nm ³ /hr	Max flow Nm ³ /hr	Min flow Nm ³ /hr	Max flow Nm ³ /hr	Min flow Nm ³ /hr	Max flow Nm ³ /hr	Min flow Nm ³ /hr	Max flow Nm ³ /hr
25 mm	1"	0.53	53	1.05	105.9	1.58	158.8	2.11	211.8
32 mm	1 1/4"	0.87	86.7	1.73	173.5	2.6	260.3	3.47	347.1
40 mm	1 1/2"	1.36	135.6	2.71	271.1	4.06	406.7	5.42	542.3
50 mm	2"	2.12	211.9	4.23	423.7	6.35	635.5	8.47	847.4
65 mm	2 1/2"	3.58	358.1	7.1	716.1	10.7	1074.1	14.3	1432.2
80 mm	3"	5.42	542.3	10.8	1084.7	16.2	1627.1	21.6	2169.4
100 mm	4"	8.47	847.5	16.9	1694.9	25.4	2542.3	33.8	3389.8
125 mm	5"	13.2	1324.2	26.4	2648.3	39.7	3972.4	52.9	5296.6
150 mm	6"	19.1	1906.8	38.1	3813.5	57.2	5720.3	76.2	7627.1
200 mm	8"	33.9	3389.8	67.7	6779.6	101.6	10169.4	135.5	13559.3
250 mm	10"	53	5296.6	105.9	10593.2	158.8	15889.8	211.8	21186.4
300 mm	12"	76.3	7627.1	152.5	15254.2	228.8	22881.3	305	30508.4

Mode number

The standard model number is usually TGF680-1-2-I2-1-N-T-M-N-1-1-XXXX, Please reference to the table below for what the model codes stand for.

Mode codes

1	General model	TGF680	Standard	
		1	Air/nitrogen	Standard
2	Fluid type	2	Oxygen (sensor will be decreased)	Option
		3	Other (Please advise gas composition)	Option
		1	0.3~30 Nm/s	Option
3	Measurement range	2	0.6~60 Nm/s	Standard
		3	0.9~90 Nm/s	Option
		4	1.2~120 Nm/s	Option
		5	1.5~150 Nm/s	Option
		6	1.8~180 Nm/s	Option
		7	0.9~240 Nm/s	Option
		11	Insertion type with 290mm probe	Option
4	Process connection	I2	Insertion type with 440mm probe	Standard
		I3	Insertion type with 690mm probe	Option
		I4	Insertion type with 1000mm probe	Option
		I5	Insertion type with 1500mm probe	Option
		F1	Flanged insertion type up to 25 barG (362 psiG)	Option
		F2	Flanged insertion type up to 40 barG (580 psiG)	Option
		F2	Flanged insertion type up to 63 barG (913 psiG)	Option
		D1	Flanged DIN PN16 up to 16 barG (232 psiG) (DN15~DN300)	Option
		D2	Flanged DIN PN25 up to 25 barG (362 psiG) (DN15~DN300)	Option
		D3	Flanged DIN PN40 up to 40 barG (580 psiG) (DN15~DN300)	Option
		D4	Flanged DIN PN63 up to 63 barG (913 psiG) (DN15~DN300)	Option
		C1	Flanged ANSI CL150 up to 16 barG (232 psiG) (0.5 inch~12 inch)	Option
		C2	Flanged ANSI CL300 up to 40 barG (580 psiG) (0.5 inch~12 inch)	Option
		C3	Flanged ANSI CL400 up to 63 barG (913 psiG) (0.5 inch~12 inch)	Option
		J1	JIS 10K up to 16 barG (232 psiG) (DN15~DN300)	Option
J2	JIS 20K up to 40 barG (580 psiG) (DN15~DN300)	Option		
J3	JIS 30K up to 63 barG (913 psiG) (DN15~DN300)	Option		

5	Wet part material	1	316ss sensor with 304ss wet parts	Standard
		2	316ss sensor with 316ss wet parts	Option
6	Sensor max temperature	N	< 150°C	Standard
		Q	< 250°C	Option
		H	< 450°C (please select remote display also)	Option
7	Transmitter	T	Integral	Standard
		R	Remote	Option
8	Cable grinder	M	M20 x 1.5	Standard
		N	NPT 1/2	Option
9	Ex-proof	N	No Ex-proof	Standard
		1	NEPSI Ex d IIC T3 Gb	Option
10	Transmitter	1	pulse/frequency + RS485 + Bluetooth	Option
		2	pulse/frequency + 3*4~20mA + RS485 + Bluetooth	Standard
		3	pulse/frequency + 3*4~20mA@HART + Bluetooth	Option
11	Power supply	1	13.5~42VDC	Standard
		2	13.5~42VDC with 85~265VAC 50/60Hz power converter	Option
12	Pipe size	xxxx	please use 4 digit pipe size, such as DN50=0050, DN300=0300	xxxx

TGF460 THERMAL MASS FLOW METER

Working principle

TGF460 Series Thermal Mass Flowmeter is COMATE's latest technology specially designed for air and N2 applications. It has more compact design, which means smaller enclosure and thinner insertion tube probe. It can be installed / removed without stopping the fluid, as the pipe is thinner, field engineers will be able to insert the meter to pipe very easily. Also, TGF460 will be the most cost-effect model in the market.

Special features

- Direct mass flow or normal flow measurement
- 100:1 turn down ratio in 6 ranges: 0.3~30 Nm/s, 0.6~60 Nm/s, 0.9~90Nm/s , 1.2~120Nm/s, 1.5~150Nm/s,1.8~180Nm/s
- Large LCD screen with dual-line display and 3 setting button. Easy to read or set
- Low cost economical model.
- No pressure loss, suitable for pipe in any shape with known sectional area
- Available for hot tapping installation
- High accuracy data acquisition circuit to ensure outstanding repeatability and accuracy of the flow meter
- High efficiency design of power supply, the total power consumption is only 60mA@24VDC
- 15V~32V wide voltage range input to fit in all electricity environment
- Self-diagnose function makes trouble shooting easier

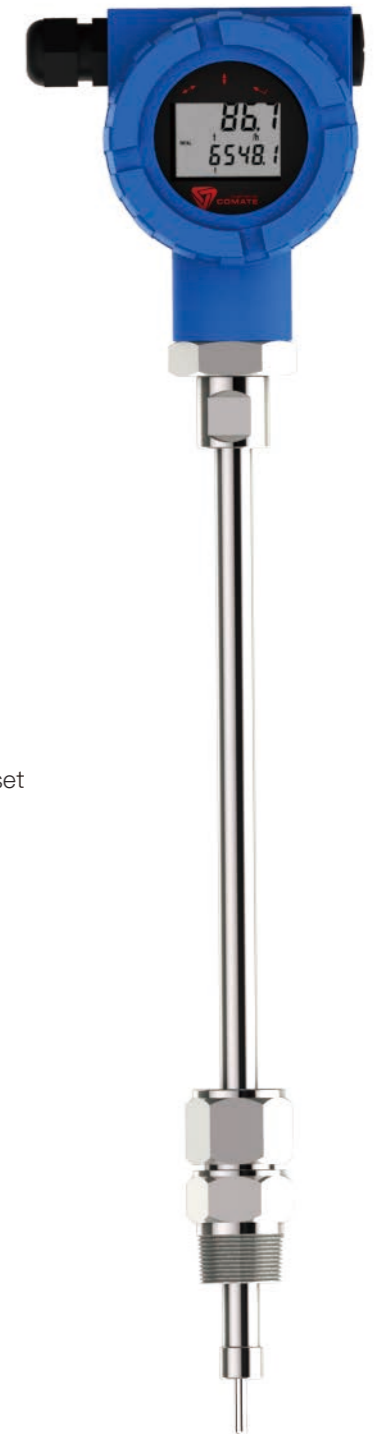

Specification

Media Compatibility	Air, Nitrogen
Pipe diameter	Insertion: DN25 ~ DN600 Inline: DN25 ~ DN300
Flow velocity range	0.3 ~ 30Nm/s 0.6 ~ 60Nm/s 0.9 ~ 90Nm/s 1.2 ~ 120Nm/s 1.5 ~ 150Nm/s 1.8 ~ 180Nm/s
Accuracy	1.5% RD ± 0.5% FS
Temperature of medium	-40 ~ +150°C
Pressure of medium	Insertion: 1.6 MPa Flanged in-line: 1.6 MPa
Power supply	AC85~264V or DC16~32V
Response time	1 second
Output	Frequency and 4~20mA as standard
Communication	RS-485+Bluetooth as standard , 4~20mA@HART as optional
Date displayed	Mass flow, Total flow Volume flow in normal condition
Ingress protection grade	IP65 (GB China)

Insertion type with ball valve
Install/remove the meter without stopping the flow

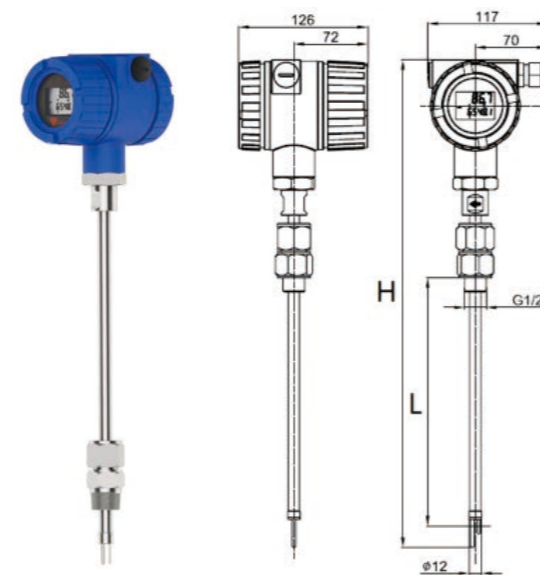

Probe	H	L
255 mm	412 mm	180 mm
320 mm	477 mm	245 mm
395 mm	552 mm	320 mm
500 mm	657 mm	425 mm



Flanged type

Standard Volume flow rate range in popular sizes

Pipe size (mm)	Pipe size (inch)	Option 1 (0.3~30 Nm/s)		Standard (0.6~60 Nm/s)		Option 2 (0.9~90 Nm/s)	
		Min Nm ³ /min	Max Nm ³ /min	Min Nm ³ /min	Max Nm ³ /min	Min Nm ³ /min	Max Nm ³ /min
25 mm	1"	0.01	0.88	0.02	1.77	0.03	2.65
32 mm	1 1/4"	0.01	1.45	0.03	2.89	0.04	4.34
40 mm	1 1/2"	0.02	2.26	0.05	4.52	0.07	6.78
50 mm	2"	0.04	3.53	0.07	7.06	0.11	10.59
65 mm	2 1/2"	0.06	5.97	0.12	11.94	0.18	17.90
80 mm	3"	0.09	9.04	0.18	18.08	0.27	27.12
100 mm	4"	0.14	14.12	0.28	28.25	0.42	42.37
125 mm	5"	0.22	22.07	0.44	44.14	0.66	66.21
150 mm	6"	0.32	31.78	0.64	63.56	0.95	95.34
200 mm	8"	0.56	56.50	1.13	112.99	1.69	169.49
250 mm	10"	0.88	88.28	1.77	176.55	2.65	264.83
300 mm	12"	1.27	127.12	2.54	254.24	3.81	381.36

Pipe size (mm)	Pipe size (inch)	Option 3 (1.2~120 Nm/s)		Option 4 (1.5~150 Nm/s)		Option 5 (1.8~180 Nm/s)	
		Min Nm ³ /min	Max Nm ³ /min	Min Nm ³ /min	Max Nm ³ /min	Min Nm ³ /min	Max Nm ³ /min
25 mm	1"	0.04	3.53	0.04	4.41	0.05	5.30
32 mm	1 1/4"	0.06	5.79	0.07	7.23	0.09	8.68
40 mm	1 1/2"	0.09	9.04	0.11	11.30	0.14	13.56
50 mm	2"	0.14	14.12	0.18	17.66	0.21	21.19
65 mm	2 1/2"	0.24	23.87	0.30	29.84	0.36	35.81
80 mm	3"	0.36	36.16	0.45	45.20	0.54	54.24
100 mm	4"	0.56	56.50	0.71	70.62	0.85	84.75
125 mm	5"	0.88	88.28	1.10	110.35	1.32	132.42
150 mm	6"	1.27	127.12	1.59	158.90	1.91	190.68
200 mm	8"	2.26	225.99	2.82	282.49	3.39	338.98
250 mm	10"	3.53	353.11	4.41	441.38	5.30	529.66
300 mm	12"	5.08	508.47	6.36	635.59	7.63	762.71

Max pipe size that each probe can adapt to				
Probe length	255mm	320mm	395mm	500mm
T < 50 dgr C	DN100	DN250	DN350	DN600
50 °C < T < 150 °C	/	/	DN50	DN350
T < 122 °F	4"	10"	14"	38"
122 °F < T < 302 °F	/	/	2"	14"

If with remote display, there is no difference on max pipe size in different temperature

Mode number

The standard model number is usually TGF460-2-I1-1-T-M-1-1-XXXX, Please reference to the table below for what the model codes stand for.

Mode codes				
1	General model	TGF460		Standard
		1	0.3 ~ 30 Nm/s	Option
		2	0.6 ~ 60Nm/s	Standard
2	Measurement range	3	0.9 ~ 90Nm/s	Option
		4	1.2 ~ 120Nm/s	Option
		5	1.5 ~ 150Nm/s	Option
		6	1.8 ~ 180Nm/s	Option
		I1	Insertion type with 255mm probe	Standard
		I2	Insertion type with 320mm probe	Option
3	Process connection	I3	Insertion type with 395mm probe	Option
		I4	Insertion type with 500mm probe	Option
		D1	Flanged DIN PN16 up to 16 barG (232 psiG) (DN15~DN300)	Option
		D2	Flanged DIN PN25 up to 25 barG (362 psiG) (DN15~DN300)	Option
		D3	Flanged DIN PN40 up to 40 barG (580 psiG) (DN15~DN300)	Option
		C1	Flanged ANSI CL150 up to 16 barG (232 psiG) (0.5 inch~12 inch)	Option
		C2	Flanged ANSI CL300 up to 40 barG (580 psiG) (0.5 inch~12 inch)	Option
		J1	JIS 10K up to 16 barG (232 psiG) (DN15~DN300)	Option
		J2	JIS 20K up to 40 barG (580 psiG) (DN15~DN300)	Option
		4	Wet part material	1
2	316ss sensor with 316ss wet parts			Option
5	Transmitter	T	Integral	Standard
		R	Remote	Option
6	Cable grinder	M	M20 x 1.5	Standard
		N	NPT 1/2	Option
7	Transmitter	1	pulse/frequency + 4~20mA + RS485 + Bluetooth	Standard
		2	pulse/frequency + 4~20mA@HART + Bluetooth	Option
8	Power supply	1	13.5 ~ 42VDC	Standard
		2	13.5 ~ 42VDC with 85~265VAC 50/60Hz power converter	Option
9	Pipe size	xxxx	please use 4 digit pipe size, such as DN50=0050, DN300=0300 (unit is mm)	xxxx

TGF260 MICRO FLOW METER

Working principle

TGF260 series micro flow meter measure dry air and nitrogen and other non-corrosive gas base on thermal mass flow measurement technology. It is designed to measure the mass and standard flow in small pipe lines in general industry and laboratory.

User can choose 4~20mA output or Modbus@RS485 to upload data to their system. TGF260 also support blue tooth communication, so users can read and set the meter on cellphone with COMATE APP.



Special features

- Thermal mass measuring technology, direct mass/standard flow measurement
- 6 digit dual line LCD screen
- Low cost economical model
- Blue tooth for operating on cellphone
- 1.5% reading + 0.3% full scale accuracy in 100:1 measurement range
- 1/2" ~ 1" (15mm~25mm) small pipe line measurement
- On-line diagnose available
- Require only 3D upstream and 0 downstream straight pipe run

Pipe size (mm)	Pipe size (inch)	Standard (0.3~30 Nm/s)		Standard (0.6~60 Nm/s)		Option 1 (0.9~90 Nm/s)	
		Min (NL/min)	Max (NL/min)	Min (NL/min)	Max (NL/min)	Min (NL/min)	Max (NL/min)
15 mm	0.5 inch	3.2	317.8	6.4	635.6	9.5	953.4
25 mm	1 inch	8.8	882.8	17.7	1765.5	26.5	2648.3

Specification

Fluid Compatibility	Air, Nitrogen and other non-corrosive fluid
Pipe diameter	15mm~25mm (1/2" ~ 1")
Flow velocity range	0.3 ~ 30 Nm/s or 0.45~45 Nm/s or 0.6~60 Nm/s
Accuracy	1.5% of reading + 0.3% of full scale
Repeatability	0.3% of reading
Storage Temperature	-20 ~ +50°C
Fluid Temperature	-40 ~ +100°C
Pressure rating	1.6 MPa
Power supply	10 ~ 35 VDC / 200 mA
Response time	160 millisecond
Output	Frequency, 4~20mA
Communication	RS~485, Bluetooth
Date displayed	Mass flow, Normal flowTotal flow
Housing	PPS, IP65
Wet part material	Aluminum alloy

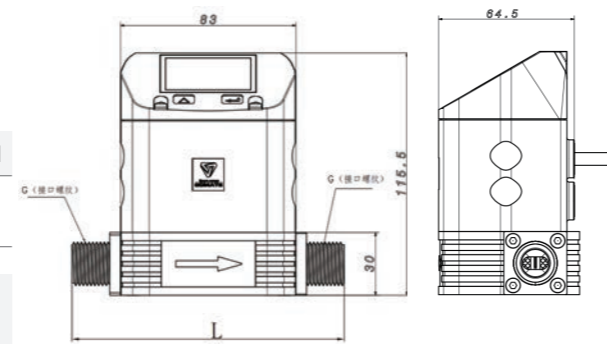

DN	L(mm)	G
15	130	G1/2"
25	160	G1"



Operation on cellphone

- Reading
- Setting
- Remote diagnose

Mode number

The standard model number is usually TGF260-2-A-XXX, Please reference to the table below for what the model codes stand for.

Mode codes

1	Model	TGF260	Basic Model	
		1	0.3 ~ 30 Nm/s	Optional
2	Flow range	2	0.45 ~ 45 Nm/s	Standard
		3	0.6 ~ 60 Nm/s	Optional
3	Output	B	frequency, 4~20mA, RS485, Bluetooth	Standard
4	Connection	G	G thread male	Standard
		15	DN15 (1/2")	Optional
5	Pipe size	25	DN25 (1")	Optional

PTF520 PITOT TUBE FLOW METER

Working principle

PTF520 Pitot tube flow meter is COMATE's latest technology base on different pressure technology specially designed for compressed air applications. As it has 1/2" insertion connection probe and compact designed sensor, it can be used on pipes from DN25~DN300. In some higher pressure applications, it can be installed / removed without stopping the fluid, as the pipe is thinner, field engineers will be able to insert the meter to pipe very easily. Also, due to its working principle, it is less effected by the water contents in the compressed air.

PTF520 Pitot tube flow meter also has integral temperature and pressure compensation, so it can measure standard flow, temperature and pressure also.

Special features

- Use Comate self-developed industrial-grade differential pressure transmitter, which is more robust than traditional Mems solutions.
- Cellphone APP for reading and setting
- Self-diagnose and remote diagnose function to provide with best support
- Bid-directional flow measurement
- No need to set 0 point
- Measures flow rate, temperature, pressure, FAD measurement available
- Wide measurement range, turndown ratio 1:30
- Fast response time
- No mechanical wear part
- Insertion mounting, available for hot tapping.
- For both dry and wet air measurement, possible for measuring compressed air at output of compressor

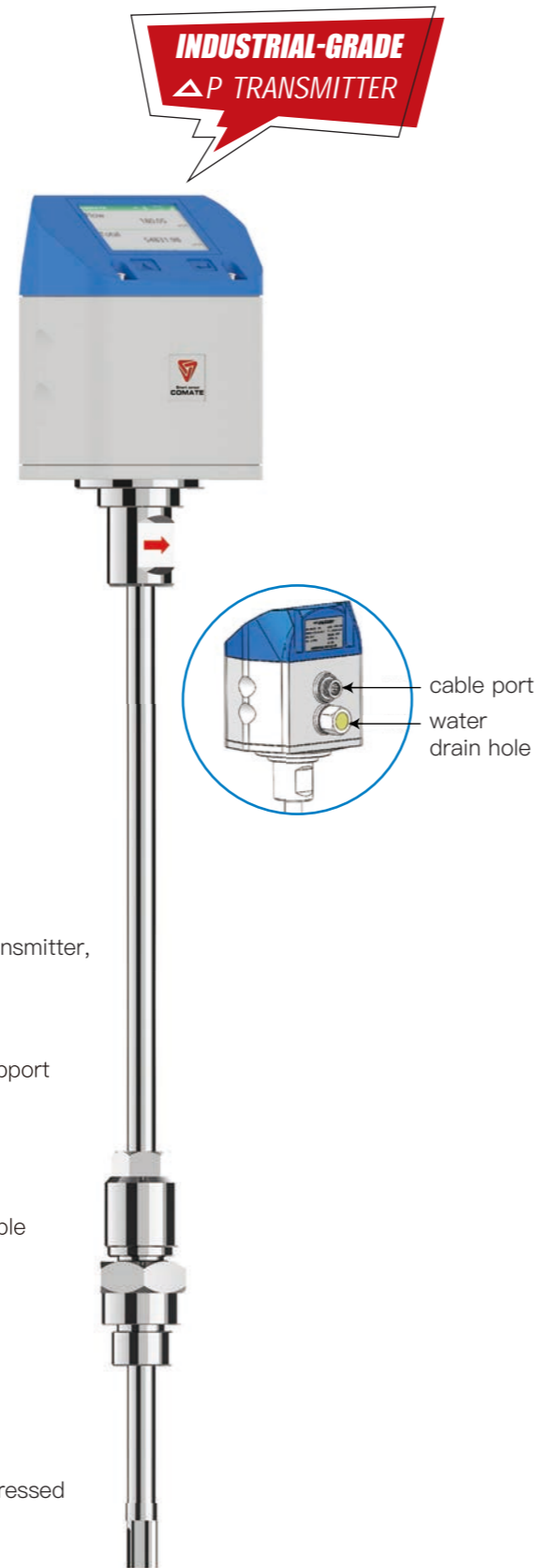

Specification

Medium	Air and none-corrosive gas
Enclosure	PC
Pipe size range	1"~24" (DN25~DN600)
Ambient temperature	-20~60°C
Atmosphere pressure	86~106 Kpa
Ambient humidity	5~100%
Process connection	1/2 G insertion with ball valve
Pressure rating	16 barG
Fluid temperature	-40~ 150°C
Wet part material	304ss
Parameter measured	Flow rate, temperature , pressure
Power	20~36V DC,150mA max
Analog	4 wire active 4~20mA
Communication	RS485@Modbus-RTU, Bluetooth
Flow Accuracy	±2%RD
Pressure Accuracy	±0.25%FS
Temperature Accuracy	±0.5°C
Flow Repeatability	±0.5%RD
Response time	1 second
Ingress Protection Grade	IP65 (avoid outdoor installation)

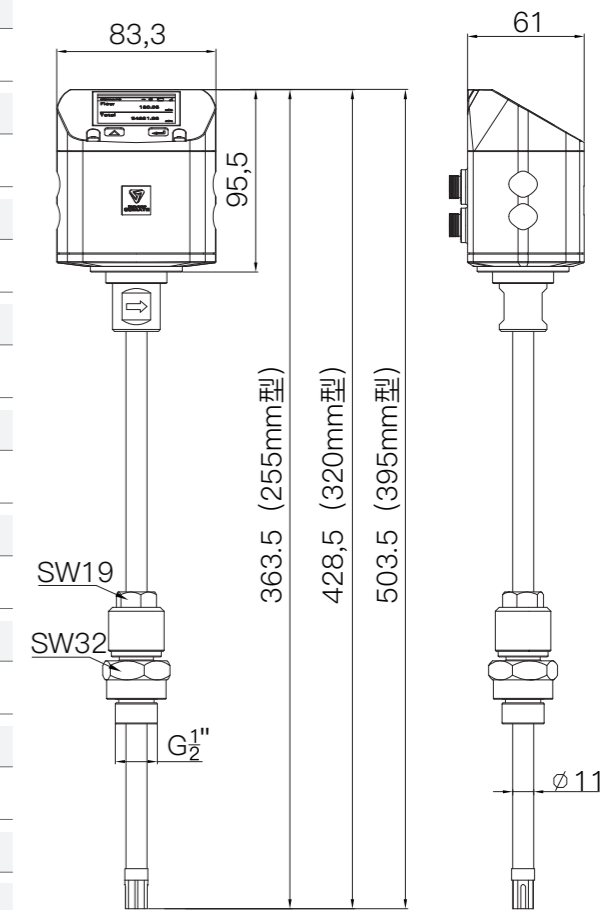

Standard flow range for compressed air @ 50 °C and different pressure, unit is Normal flow Nm³/min ref to 1.01325 barA, 0 °C

Pipe inner diameter	0 Bar G		4 Bar G		6 Bar G		7 Bar G		8 Bar G			
	DN	inch	Min	Max	Min	Max	Min	Max	Min	Max		
DN25	1"		0.11	1.92	0.24	4.29	0.29	5.07	0.31	5.42	0.33	5.75
DN32	1 1/4"		0.18	3.14	0.4	7.02	0.48	8.31	0.51	8.88	0.54	9.42
DN40	1 1/2"		0.28	4.91	0.63	10.97	0.98	12.99	0.8	18.88	0.85	14.72
DN50	2"		0.44	7.66	0.99	17.14	1.71	21.28	1.25	21.69	1.32	23
DN65	2 1/2"		0.74	12.95	1.67	28.97	1.97	34.28	2.11	36.65	2.24	38.87
DN80	3"		1.13	19.63	2.54	43.89	2.99	51.94	3.2	55.52	3.4	58.89
DN100	4"		1.77	30.67	3.96	68.59	4.68	81.15	5.01	86.76	5.31	92.02
DN125	5"		2.76	47.92	6.18	107.17	7.32	126.80	7.82	135.56	8.3	143.78
DN150	6"		3.98	69.01	8.91	154.32	10.54	182.60	11.27	195.21	11.95	207.05
DN200	8"		7.08	122.69	15.84	274.36	18.74	324.62	20.03	347.04	21.25	368.09
DN250	10"		11.06	191.71	24.75	428.68	29.28	507.23	31.3	542.25	33.2	575.14
DN300	12"		15.93	276.06	35.64	617.31	42.17	730.41	45.08	780.84	47.81	828.2

Socket tube (Material according to pipeline)

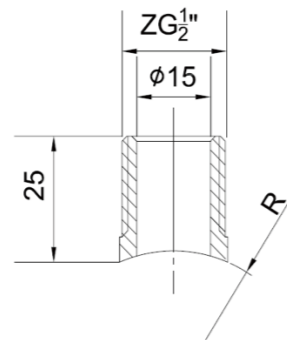

Read & Set on Screen

PTF520 has integral TFT 2" High Resolution display with two capacitive key for setting

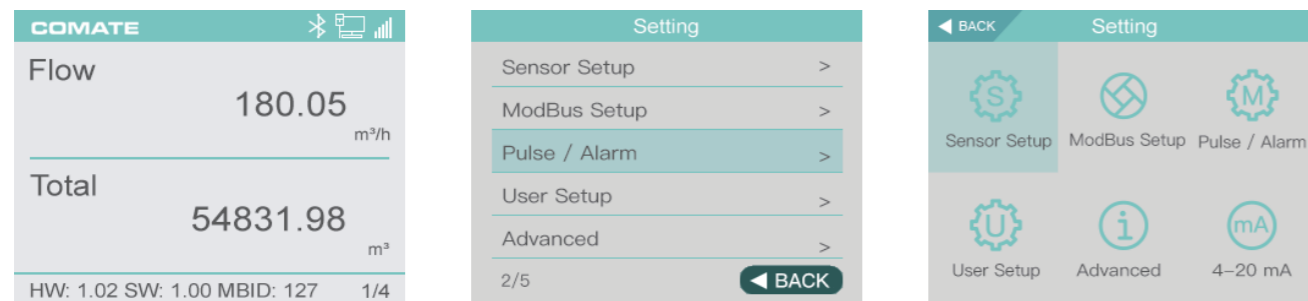

Read & Set on in COMATE APP

Instead of traditional keyboard, COMATE PTF520 implement a cellphone setting system. All PTF520 have Bluetooth communication. Users can install COMATE APP on their cellphone or tablet and use the APP to connect with a PTF520 flow meter to read or set the flow meter.

This APP also support a remote diagnose function. Whenever there is anything wrong with the flow meter, customer can ask for a remote diagnose support. When this function is working, COMATE engineer back in office can remotely check the setting of the meter, and the signal of sensor, to provide users with most accurate trouble shooting advise.

COMATE APP has made the using of the product simple and efficient .

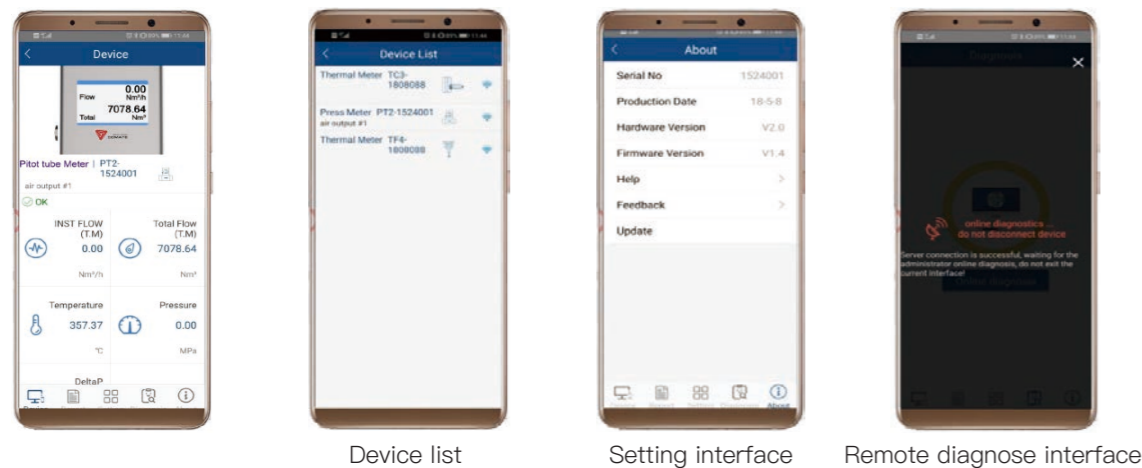

Device list

Setting interface

Remote diagnose interface

Mode number

The standard model number is usually PTF520-D-3-1-1-T-2-1-1-1-XXX, Please reference to the table below for what the model codes stand for.

Mode codes

1	General model	D	Insertion (G 1/2) ,anti-ejection design with ball valve	Standard
		1	255mm, 11mm dia (1"~4" or DN25-DN100)	Option
2	Probe Length	2	320mm, 11mm dia (1"~8" or DN25-DN200)	Option
		3	395mm, 11mm dia (1"~12" or DN25-DN300)	Standard
		4	500mm, 11mm dia (1"~24" or DN25-DN600)	Option
3	Probe Material	1	304 SS	Standard
		2	316 SS	Option
		1	Carbon steel	Standard
4	Socket material	2	304 SS	Option
		3	316 SS	Option
5	Transmitter	T	Integral	Standard
6	Pressure Rating	2	16 Bar G	Standard
7	Display and output	1	Local display, RS485, Bluetooth	Standard
		2	Local display, 4wire 4~20mA, RS485, Bluetooth	Option
8	Power supply	1	20~36VDC	Standard
		N	20~36VDC with 24VDC to AC power concenter	N
9	Ingress protection grade	1	IP65(Avoid outdoor installation)	Standard
10	Pipe size	XXX	please use 3 digit pipe size, such as DN50=050, DN200=200	XXX

Remark:

- Hot-tap hole opener are as accessories, please remark if you need any of them
- Please indicate flow rate along with the model number selected
- If anything beyond this chart, please check with us to see the availability
- The model selected in 1st line is the standard configuration with no accessories

PTF600 PITOT TUBE FLOW METER

Working principle

PTF600 Pitot tube flow meter is COMATE's heavy duty designed flow meter for wet and dry air. It has an wide turn down DP transmitter which ensures it a 33:1 wide measurement range and better stability. It has an unique water-proof design which can solve the problem that caused by condensing water in capillary.

PTF600 Pitot tube flow meter also has integral temperature and pressure compensation, so it can measure standard flow, temperature and pressure also.



Special features

- Cellphone APP for reading and setting
- Self-diagnose and remote diagnose function to provide with best support
- For both dry and wet air measurement, possible for measuring compressed air at output of compressor
- Multi-variable flow meter, measures flow rate, temperature, pressure, FAD measurement available
- Super wide turn down of 33:1, best in market
- Fast response time
- No mechanical part
- Insertion mounting, available for hot tapping.
- Special water proof design, no worry about condensing water blocking the capillary
- Heavy duty design, more durable in tough measurement environment

Standard flow range for compressed air @ 50 °C and different pressure, unit is Normal flow Nm³/min ref to 1.01325 barA, 0 °C

Pipe inner diameter			2 Bar G		3 Bar G		4 Bar G		5 Bar G		6 Bar G	
DN	mm	inch	Min	Max	Min	Max	Min	Max	Min	Max	Min	Max
DN25	27.3	1"	0.13	4.28	0.15	4.79	0.16	5.24	0.18	5.66	0.19	6.05
DN32	36	1 1/4"	0.23	7.45	0.26	8.33	0.28	9.12	0.31	9.85	0.33	10.53
DN40	41.9	1 1/2"	0.31	10.09	0.35	11.28	0.38	12.35	0.41	13.34	0.44	14.26
DN50	53.1	2"	0.50	16.21	0.56	18.11	0.62	19.84	0.67	21.43	0.71	22.90
DN65	68.9	2 1/2"	0.85	27.29	0.95	30.50	1.04	33.40	1.12	36.07	1.20	38.56
DN80	80.9	3"	1.17	37.62	1.31	42.05	1.43	46.05	1.54	49.73	1.65	53.16
DN100	110	4"	2.16	69.55	2.41	77.74	2.64	85.14	2.86	91.94	3.05	98.28
DN125	133.7	5"	3.19	102.75	3.57	114.84	3.91	125.78	4.22	135.83	4.51	145.19
DN150	159.3	6"	4.53	145.87	5.06	163.03	5.55	178.55	5.99	192.83	6.40	206.12
DN200	200	8"	7.14	229.93	7.98	256.98	8.74	281.45	9.44	303.95	10.09	324.90
DN250	250	10"	11.16	359.26	12.47	401.53	13.66	439.76	14.75	474.92	15.77	507.65
DN300	300	12"	16.07	517.33	17.96	578.21	19.67	633.25	21.24	683.89	22.70	731.02

Standard flow range for compressed air @ 50 °C and different pressure, unit is Normal flow Nm³/min ref to 1.01325 barA, 0 °C

Pipe inner diameter			7 Bar G		8 Bar G		9 Bar G		10 Bar G		12 Bar G	
DN	mm	inch	Min	Max	Min	Max	Min	Max	Min	Max	Min	Max
DN25	27.3	1"	0.20	6.42	0.21	6.77	0.22	7.10	0.23	7.41	0.25	8.01
DN32	36	1 1/4"	0.35	11.16	0.37	11.77	0.38	12.34	0.40	12.89	0.43	13.92
DN40	41.9	1 1/2"	0.47	15.12	0.50	15.94	0.52	16.72	0.54	17.46	0.59	18.86
DN50	53.1	2"	0.75	24.29	0.80	25.60	0.83	26.85	0.87	28.04	0.94	30.29
DN65	68.9	2 1/2"	1.27	40.89	1.34	43.10	1.40	45.20	1.47	47.21	1.58	50.99
DN80	80.9	3"	1.75	56.38	1.85	59.42	1.94	62.32	2.02	65.09	2.18	70.30
DN100	110	4"	3.24	104.23	3.41	109.86	3.58	115.22	3.74	120.34	4.04	129.97
DN125	133.7	5"	4.78	153.99	5.04	162.30	5.29	170.22	5.52	177.78	5.96	192.01
DN150	159.3	6"	6.79	218.60	7.16	230.41	7.51	241.64	7.84	252.37	8.47	272.57
DN200	200	8"	10.70	344.57	11.28	363.19	11.83	380.89	12.36	397.81	13.34	429.65
DN250	250	10"	16.72	538.40	17.62	567.48	18.48	595.14	19.31	621.57	20.85	671.32
DN300	300	12"	24.08	775.29	25.38	817.17	26.62	857.00	27.80	895.06	30.02	966.70

Specification

Media Compatibility	Dry and wet air
Pipe diameter	Insertion type: DN25~400mm Inline type: DN15~300mm
Different pressure range	6~6220 Pa, please reference to next subject on how to calculate flow rate range
Accuracy	1% RD+ ±0.5% FS
Temperature of medium	- 25 ~ +120°C
Pressure of medium	Insertion type :16 barG Inline type : 4 MPa
Power supply	DC 15~32V (AC85~264V power converter available)
Response time	1 second
Output / Communication	RS485, Bluetooth (4~20mA optional)
Date displayed	Mass flow, Volume flow in normal condition, Total flow, Temperature of medium. Velocity
Ingress protection grade	IP65 (GB China)

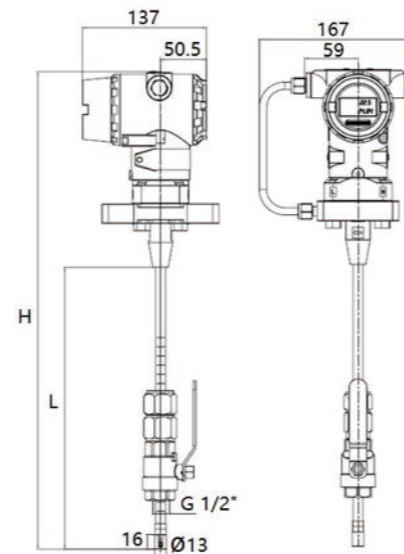

Probe	H	L	Pipe size available
255 mm	460 mm	245 mm	DN150
320 mm	525 mm	310 mm	DN250
395 mm	600 mm	385 mm	DN400

Operation on cellphone

- Reading
- Setting
- 0 point reset
- Remote diagnose

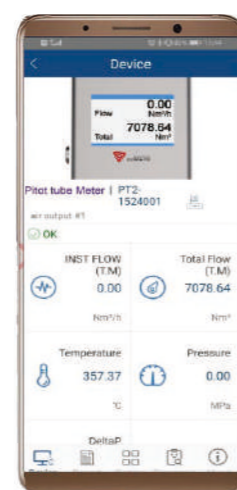

Mode number

The standard model number is usually PTF600-I1-T-1-1-XXXX, Please reference to the table below for what the model codes stand for.

Mode codes

1	General model	PTF600	Standard			
		I1	Insertion type with 255mm probe	Standard		
2	Process connection	I2	Insertion type with 320mm probe	Option		
		I3	Insertion type with 395mm probe	Option		
		I4	Insertion type with 670mm probe	Option		
		I5	Insertion type with 1000mm probe	Option		
		F1	Flanged insertion type up to 25 barG (362 psiG)	Option		
		F2	Flanged insertion type up to 40 barG (580 psiG)	Option		
		D1	Flanged DIN PN16 up to 16 barG (232 psiG) (DN15 ~ DN300)	Option		
		D2	Flanged DIN PN25 up to 25 barG (362 psiG) (DN15 ~ DN300)	Option		
3	Probe Material	D3	Flanged DIN PN40 up to 40 barG (580 psiG) (DN15 ~ DN300)	Option		
		C1	Flanged ANSI CL150 up to 16 barG (232 psiG) (0.5 inch ~ 12 inch)	Option		
		C2	Flanged ANSI CL300 up to 40 barG (580 psiG) (0.5 inch ~ 12 inch)	Option		
		J1	JIS 10K up to 16 barG (232 psiG) (DN15 ~ DN300)	Option		
		J2	JIS 20K up to 40 barG (580 psiG) (DN15 ~ DN300)	Option		
		1	304ss	Option		
		2	316ss	Option		
		4	Transmitter	T	Integral	Standard
				R	Remote	Option
		5	Transmitter	1	pulse/frequency + RS485 + Bluetooth	Standard
2	pulse/frequency + 4~20mA + RS485 + Bluetooth			Option		
6	Power supply	1	13.5 ~ 42VDC	Standard		
		2	13.5 ~ 42VDC with 85~265VAC 50/60Hz power converter	Option		
7	Pipe size	xxxx	please use 4 digit pipe size, such as DN50=0050, DN300=0300	xxxx		

CAE520 COMPRESSED AIR NETWORKING AUDITING SYSTEM

General

CAE520 Compressed air network auditing system is designed as a convenient and efficient method of compressor and compressed network energy efficiency measurement and monitor.

Basic CAE520 includes a PTF520 pitot tube flow meter which support hot tap installation and an IoT data logger which can upload measurement data to cloud server from 4G modular for remote monitoring anywhere in the world with internet access.

Optional parts include KW110M IoT power meter for power consumption measurement, hot tape drilling tool for installation, and clamp on socket for installation without welding.

After hardwares are installed and powered, users can log in COMATE compressor monitoring system website to review real time and historical data and download reports. It saves service provider from site visit for acquiring data storage device, and can check dynamic real time data remotely to provide service in time.

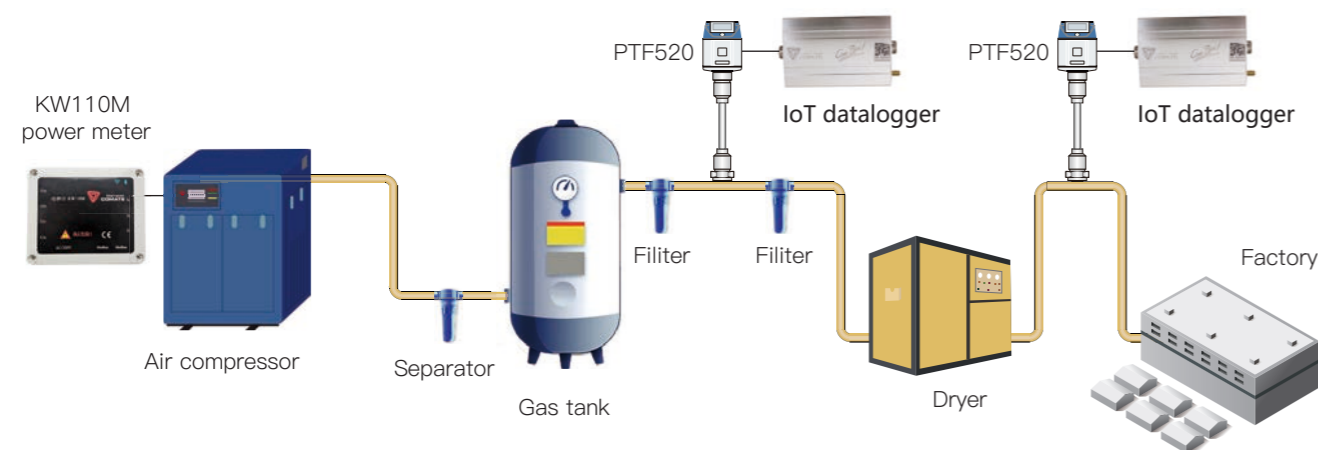

Specification

System	Power supply Ambient temperature	AC220V +/-5%, or AC/DC 85-265V, or AC380V±5% -40~80 dgr °C
Power meter	Wiring Voltage measurement range Voltage accuracy Current measurement range Current accuracy Power efficiency range Power efficiency accuracy	3 phase 3-wire or 3 phase 4-wires 2nd grade voltage test AC 0~400V 0.20% 2nd grade 0~5A (transformer ratio 500:5) 0.20% up to250KW 0.50%
PTF520 flow meter	Pipe size Measurement range and accuracy Other	DN25~DN300 2.0% of reading Please reference to PTF520 data

CAE520 sample report

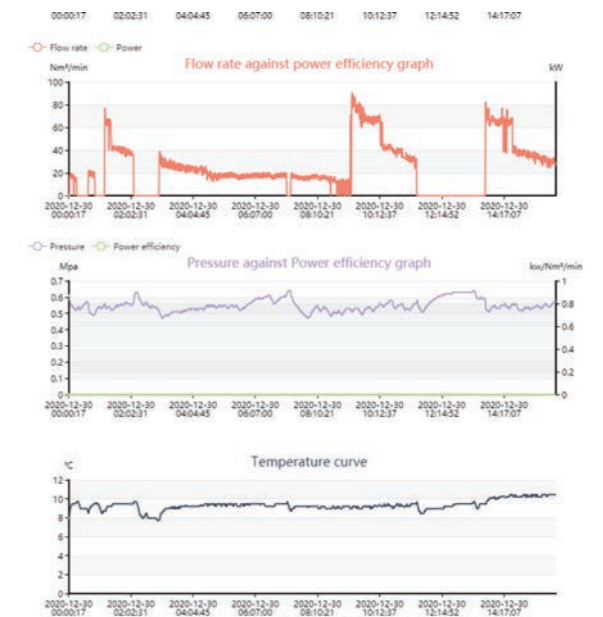
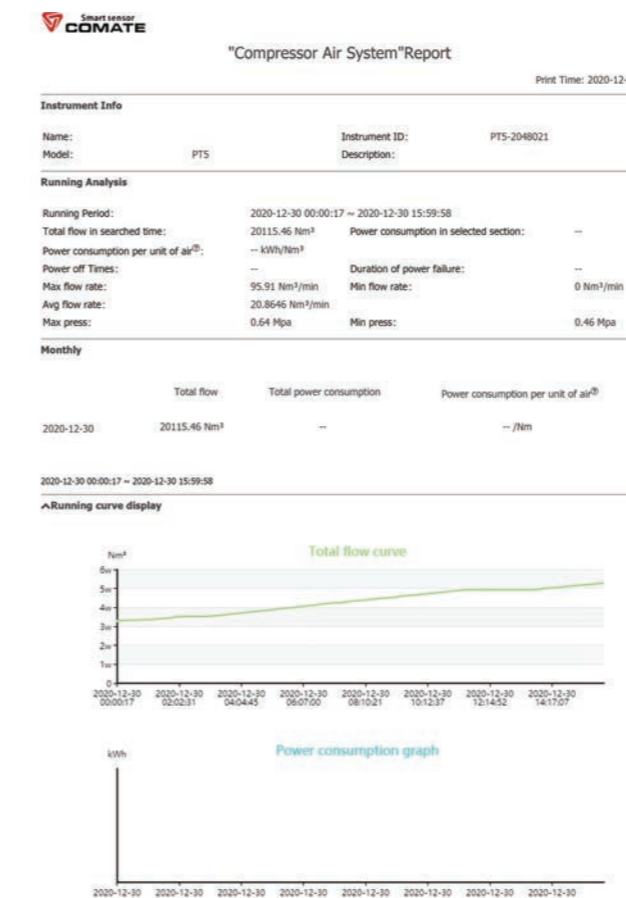

CAE350S COMPRESSOR ANALYZING SYSTEM

Working principle

CAE350S compressor Analyzing System is Comate Intelligent Sensor's latest solution specially designed for analyzing the performance of compressor. The system integrated flow meter (humidity sensor built inside), pressure sensor, power meter through pad APP and Bluetooth communication technology. Users will be able to read not only the standard flow rate, FAD flow rate, pressure, power consumption and efficiency, but also load/off loading times, unit power (power consumption per unit of compressed air), and power ratio (power efficiency under a certain productivity of compressed air).

TGF350S flow meter, receiver data from power meter and transfer all data to cell phone through bluetooth

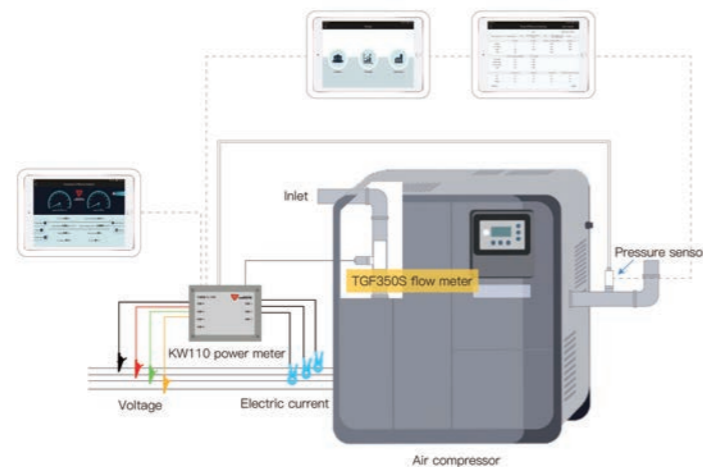

CAE350S do not have traditional display and setting system. To read or set the system, customer only need to use an PAD installed COMATE APP. All the hardware ingredients in the system will transfer date to TGF350 flow meter and the flow meter will communicate with cell phone / pad. Anyone can easily read the date or set the system. The APP can also generate an detailed report with curve diagram to help customer to understand the condition of the compressor better or even compare the tested compressor with another compressor. Thanks for the compact design of the system, users are able to bring the whole system anywhere with only a simple wheel box provided by Comate. Engineers or sales person will be able to bring only one wheel box to check the performance of most of the compressor accurately and efficiently.



Specification

System	Power supply	AC220V +/-5%, or AC/DC 85~265V, or AC380V±5%
	Ambient temperature	-40 ~ 80 dgr C
APP	For Android PAD	For PAD with resolution of 1920*1200 , Android 4.4 or higher version
Power meter	Wiring	3 phase 3-wire or 3 phase 4-wires
	Voltage measurement range	2nd grade voltage test AC 0 ~ 400V
	Voltage accuracy	0.20%
	Current measurement range	2nd grade 0~5A (transformer ratio 500:5)
	current accuracy	0.20%
	Power efficiency range	up to 250Kw
	Power efficiency accuracy	0.50%
DN100 TGF350S flow meter	Inlet pipe size	DN40~DN100 (1.5" ~ 4")
	Measurement range and accuracy	2% accuracy in 1~30 Nm³/min (35~1060 SCFM)
DN200 TGF350S flow meter	Inlet pipe size	DN100~DN200 (4"~ 8")
	Measurement range and accuracy	2% accuracy in 10~130 Nm³/min (353~4590 SCFM)
Humidity	Accuracy	+/- 4.5 RH
Temperature	Accuracy	0.5 dgrC

System Components

1. TGF350S inlet air flow meter

TGF350S inlet air flow meter is designed base on differential pressure theory, can measure the mass flow rate, standard flow rate and FAD flow rate in a 70:1 range with 2% accuracy.

CAE350S system contains 2 TGF350S flow meters, one in 4" (DN100) and one in 8" (DN200). With our rubber hose (pipe size adapter), this two meters can fit in pipe size from 1.5" to 8" (DN40~DN200). TGF350S gather all the data from other components in the system through RS485 and transfer them to pad through blue tooth.

TGF350 flow meter should be installed on the inlet of the compressor, after the filters. Thus it will not be effected by the water contents, which is normally contained in the compressed air in the pressurized pipeline and will greatly effects the measurement result of traditional thermal mass flow meter. Also it will be much easier to install and remove than traditional flow meter which has to be installed on pressurized pipes.

Beside flow rate reading, TGF350S also can provide customer with RH reading and temperature for reference.

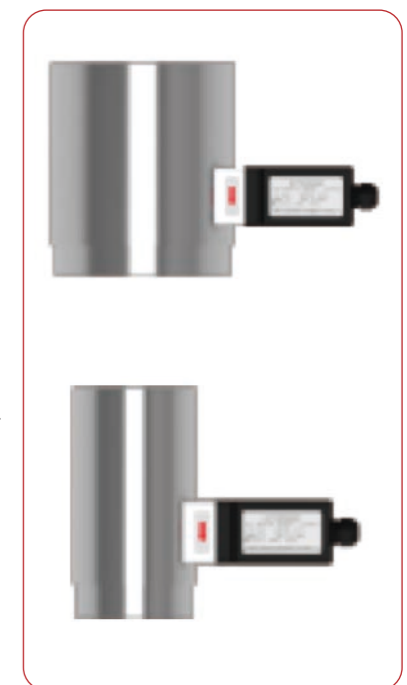

2. Power measurement components

One KW110 power meter, 3 current transformers and 4 voltage claspers are the power measurement components in CAE350S system. KW110 gather current and voltage date from the other two components through RS485 and transfer all data to TGF350 flow meter also through RS485. Also, KW110 is the only component that is needed to be plugged to a power source and it will provide power for the whole system.

The power measurement components can be used in both 3 phase 3-wire and 3 phase 4-wire power system, with 1% accuracy in a 5~500A range. All components can be read and set through cell phone / pad APP.

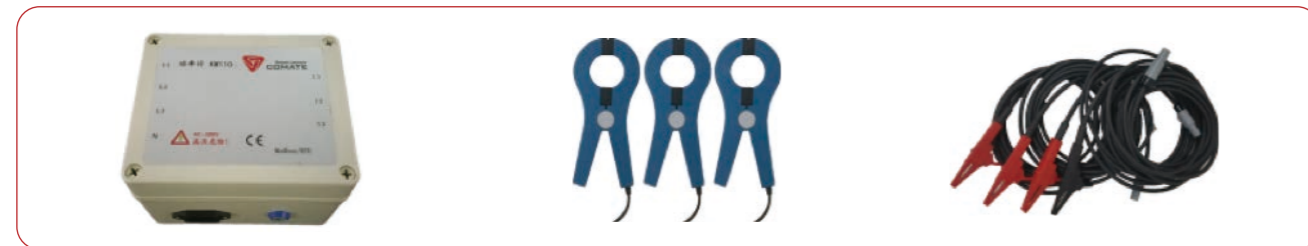

3. Pressure sensor

CAE350S system also include a pressure sensor which can be installed on the pressure tap of the compressor. The pressure sensor will output analog signal for pressure value to flow meter, so the system can compare the efficiency of the compressor under different pressure.



4. COMATE APP

Instead of traditional displaying and setting system, CAE350S system can be read and set on a PAD through blue tooth technology, by installing COMATE APP.

The setting dates are saved in flow meter separately, but all measurement dates are saved in TGF350S flow meter, which is the only component in CAE350S system that can built connection with the pad. Even when the pad is out of the range of the blue tooth of TGF350S, TGF350S itself can save 24 hours measurement date in built-in FRAM. So once a cell phone/ pad connect with the system again, it can read the data of latest 24 hours.

The APP can control the start and the end of a test, when the test stop, the APP will ask if need to save the data. Once the data saved on APP, customer can check it anytime later, and generate a very detailed report with curve diagram. Customer can send the report to mailbox once connected the PAD to internet.

Through the help of Comate Flow Meter APP, customer can operate the system very easily with almost 0 training after registration and understanding some basic terms of the system.

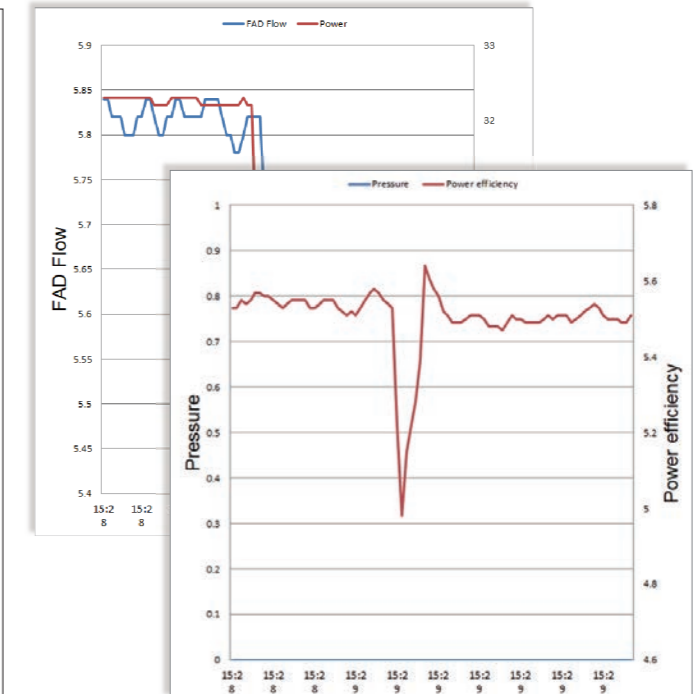
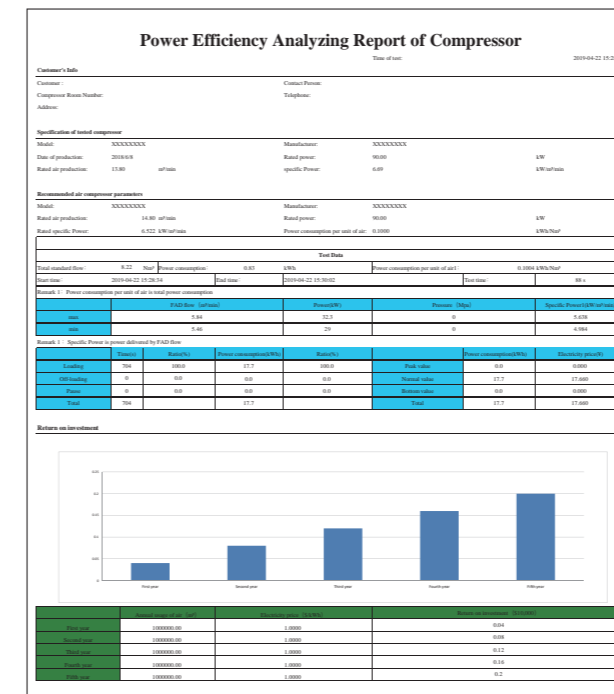

Reading interface of the APP



Setting interface of the APP



power efficiency analyzing page of the APP

5. OTHER COMPONENTS

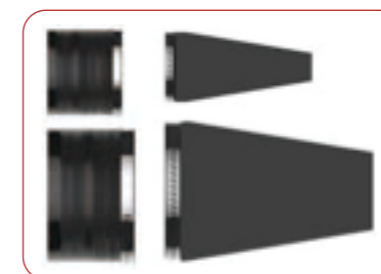

Rubber hose and pipe size adapter with screw claspers. These are for the installation of the flow meter on difference inlet pipe size



Tools set including one knife, one tape meter, one ruler, one pair of gloves and one screwdriver, for cutting rubber hose and installation of flow meter



Plastic box with wheel, holding all components inside with protection. Tough and durable

CAE820 COMPRESSED AIR NETWORK AUDITING SYSTEM

General

CAE820 compressed Air Network Auditing System is specially designed for analyzing the performance of single compressor or compressor group. The system integrated flow meter (temperature and pressure measurement inside), power meter through tablet APP and Bluetooth communication technology. Users will be able to read not only the standard flow rate, FAD flow rate, pressure, power consumption and efficiency, but also load/off loading times, unit power (power consumption per unit of compressed air), and power ratio (power efficiency under a certain productivity of compressed air).

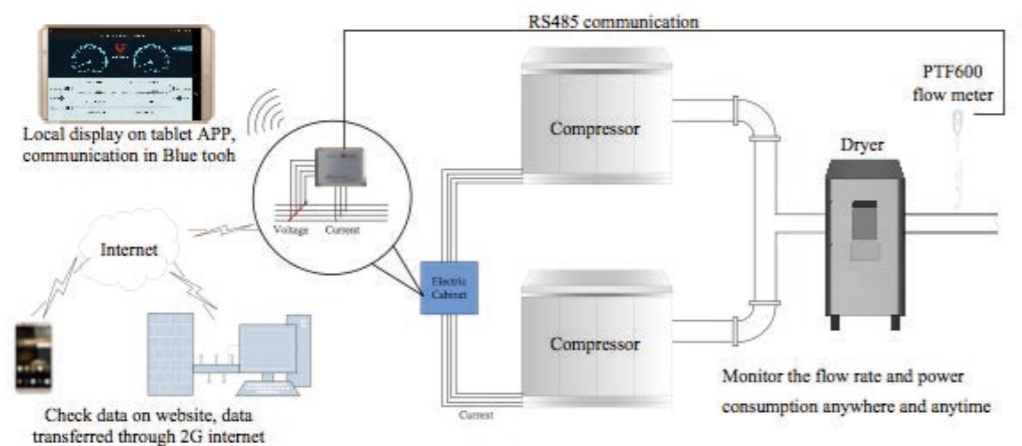

CAE820 do not rely on traditional display and setting system. To read or set the system, customer only need to use an tablet installed COMATE APP. All the hardware ingredients in the system will transfer date to flow meter and the flow meter will communicate with cell phone / pad. Anyone can easily read the date or set the system. The APP can also generate an detailed report with curve diagram to help customer to understand the condition of the compressor better or even compare the tested compressor with another compressor. The power meter can also upload the measurement data to COMATE compressor monitoring system website. So if the audit take long time, customer do not have to stay at site, but can check the data anywhere by logging the website.

Specification

System	Power supply	AC220V +/-5%, or AC/DC 85~265V, or AC380V ± 5%
	Ambient temperature	-40~80 dgr C
Power meter	Wiring	3 phase 3-wire or 3 phase 4-wires
	Voltage measurement range	2nd grade voltage test AC 0~400V
	Voltage accuracy	0.20%
	Current measurement range	2nd grade 0~5A (transformer ratio 500:5)
	current accuracy	0.20%
	Power efficiency range	up to250KW
	Power efficiency accuracy	0.50%
PTF600 flow meter	Pipe size	DN25 ~ DN400
	Measurement range and accuracy	1% RD + 0.5%FS in 1:32 flow range

System Components

1. PTF600 pitot tube flow meter set

CAE820 has one PTF600 pitot pipe flow meter. PTF600 is COMATE'S latest compressed air flow meter base on different pressure principle designed for both dry and wet air. PTF600's can measure a flow range of 32:1 with 1%RD + 0.5%FS accuracy. The min and max flow are base on the pressure and pipe size.

PTF600 should be installed on pressurized compressed air pipeline. With the hot tap drilling tools contained in the package, customer can install and remove the meter without stopping the flow. PTF600 can also measure temperature and pressure, and will communicate with the power meter. All the data will be transferred to power meter and then transferred to tablet or internet

For detail measurement range of this flow meter, please ref to the datasheet of this product.



2. Power measurement components

One KW110M power meter, 3 current transformers and 4 voltage claspers are the power measurement components in CAE820 system. KW110M gather current and voltage data from the other two components through RS485 and flow rate, temperature, pressure data from PTF600 flow meter. It can communicate with tablet through blue tooth or update data to COMATE Compressor Monitoring System website for customer to review. The power measurement components can be used in both 3 phase 3-wire and 3 phase 4-wire power system, with 1% accuracy in a 5~500A range.



3. COMATE APP

Instead of traditional displaying and setting system, CAE820 system can be read and set on a tablet through blue tooth technology, by installing COMATE APP. The setting data and measurement data are firstly saved in KW110M separately (can save 1440 measurement point), only when customer finished a test that the meter will transfer all data to tablet and saved in tablet. Thus even when the pad is out of the range of the blue tooth of KW110M, KW110M itself can save 24 hours measurement date in built-in FRAM (set the time space between each measurement point to 1 minute). Once the tablet connect with the system again, it can read the data of latest 1440 measurement point.

The APP can control the start and the end of a test, when the test stop, the APP will ask if need to save the data. Once the data saved on APP, customer can check it anytime later, and generate a very detailed report with curve diagram. Customer can send the report to mailbox once connected the PAD to internet.

Through the help of Comate Flow Meter APP, customer can operate the system very easily with almost 0 training after registration and understanding some basic terms of the system.

4. Comate Compressor Monitoring System

Comate Compressor Monitoring System is a on-line monitoring system with a remote data server to save all data and a website to show all data.

Any COMATE flow meter or other items can upload data to the remote data server. Customer can logging the website with their unique ID and password to check current measuring data and history data. The website will also provide curve graphic of all available data for customer to compare and know the tendency The English of this system will be on-line soon enough.

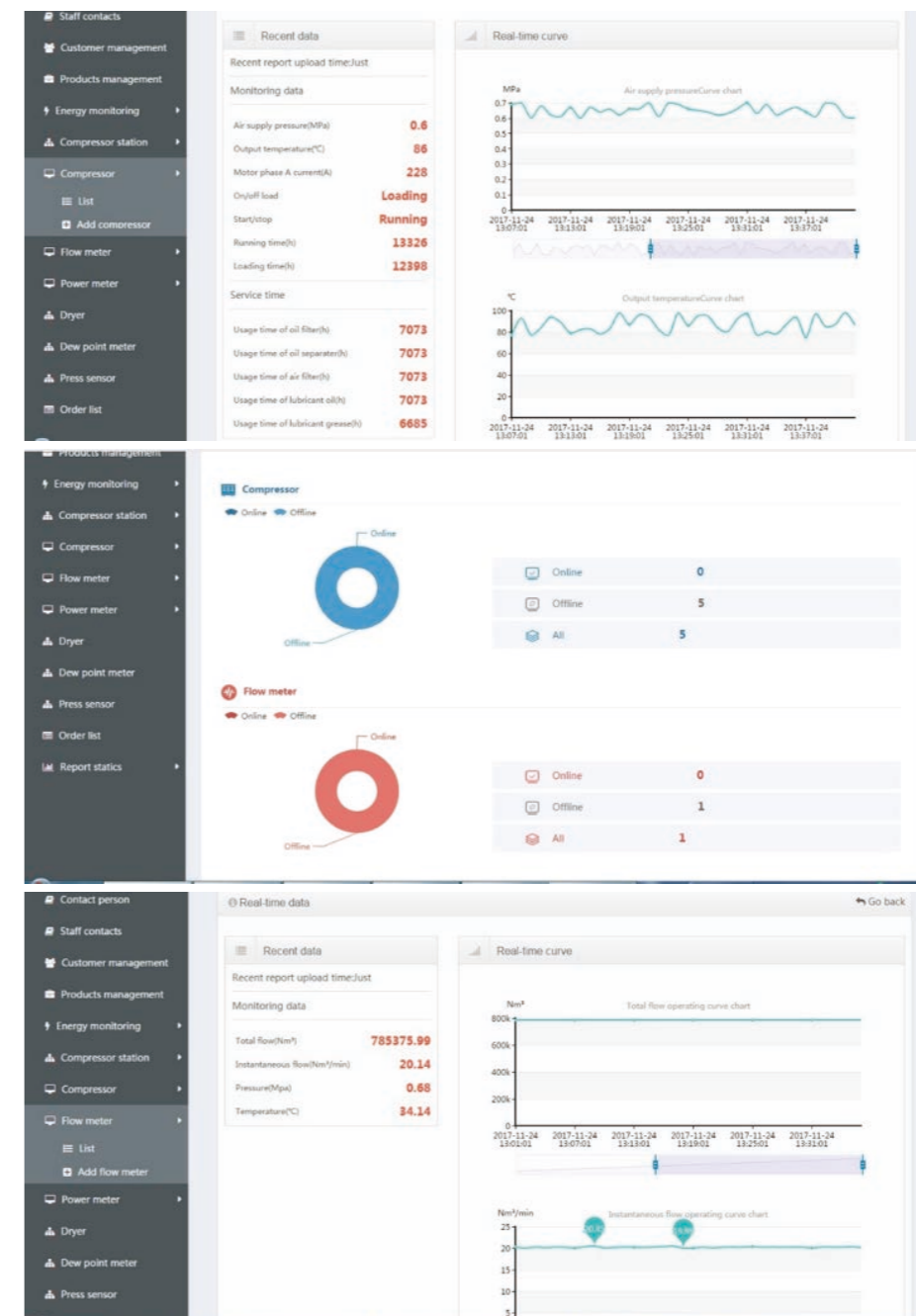

COMATE APP - SMARTPHONE OPERATION



One cellphone app FOR All COMATE flow meters

COMATE APP is specially designed user interface for flow meters from Comate Intelligent Sensor. With this application, users can connect their smart phones with the flow meters, to read, set and even remote diagnose it. It has most user friendly interface, and frees users from complicated setting list and troublesome keyboards, makes it easier to user the flow meters.

The unique Remote diagnose function saves the time and cost which happens during trouble shooting process. By some simple operations in the APP, users can upload the setting list and sensor signal to the cloud server of COMATE. Qualified engineers from COMATE will check them and give most proper trouble shooting suggestion. This is a revolutionary innovation for field instruments supporting, that can brings the best experience to users

COMATE APP is universal for all COMATE INTELLIGENT SENSOR flow meter lines. Customer can download the android version on Google Play or IOS version on Appstore.

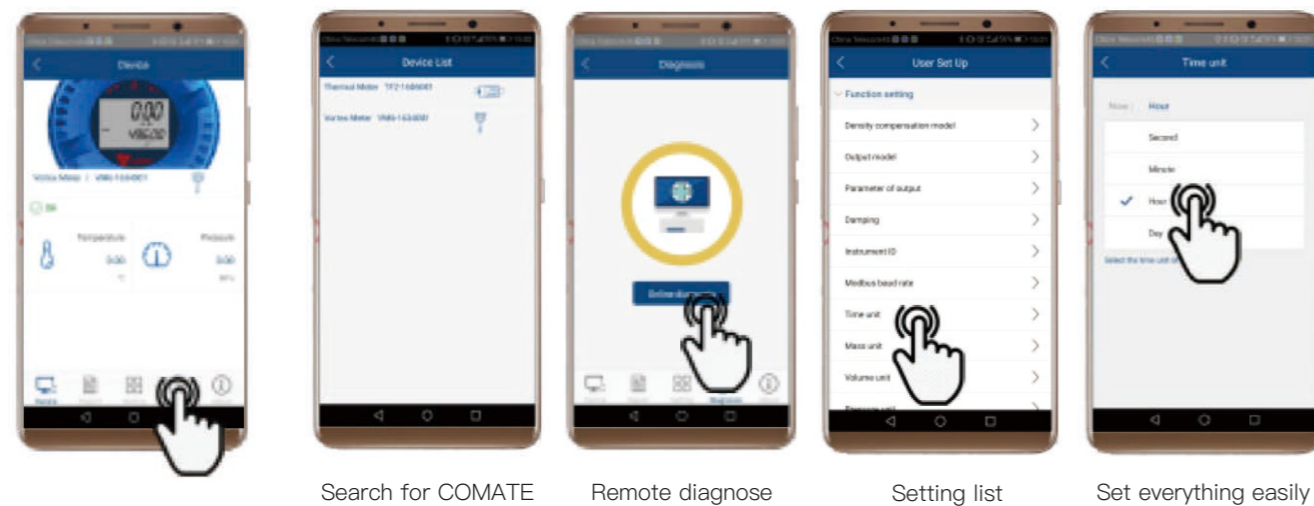

Search for COMATE flow meterst

Remote diagnose

Setting list

Set everything easily

COMATE REMOTE SUPPORT PACKAGE

Support on your measurement issues remotely

Customer relationship is important ! Good support tighten your bond with your customers.



Endless site travel



Shipping here and backcause time and cost waste



Complicated setting check

Self-diagnosis function

Use COMATE APP to run test of flowmeter, generate report indicating the status of the flow meter. Save the trouble of sending the meter back for testing.

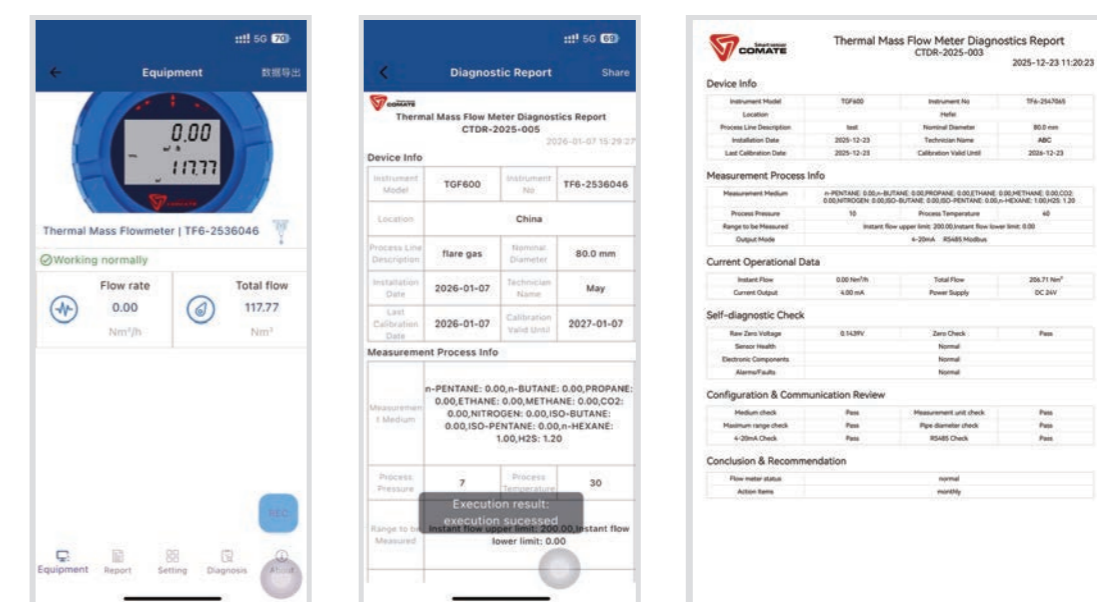

TEMPERATURE SENSOR

The PT series temperature sensor is a contact type platinum resistance temperature sensor with good electromagnetic compatibility and anti-interference performance. It supports three wire/four wire wiring and can be used in conjunction with temperature sensor acquisition instruments or computer acquisition measurement systems. It can accurately measure the temperature of various media or objects from $-200\text{ }^{\circ}\text{C}$ to $500\text{ }^{\circ}\text{C}$.

In many fields, temperature measurement is essential, especially in industries such as petroleum, chemical, power, metallurgy, etc. Temperature sensors, as key components for temperature detection, have been widely used in these industries.



Mode codes

	C-T	PT100 scale thermal resistance Class A
1	Sensor type	C-B Temperature transmitter
2	Material	1 304
		2 316
3	Accuracy	1 $\pm 0.5^{\circ}\text{C}$
4	Output	1 3 wires RTD (Transmitter)
		2 RS485
5	Thread (including piping)	1 M20*1.5
6	Ingress Protection	1 IP65
7	Temperature range	1 $-40\sim 150^{\circ}\text{C}$ (Transmitter)
		2 $-40\sim 250^{\circ}\text{C}$ (Sensor)
8	Pipe pressure	1 $\leq 4.0\text{MPa}$
9	Insertion depth	XXX pipe inner diameter+pipe thickness

Parameters

Type	Non-Exproof
Output	3 wires 4~20mA or RS485
Gauge outfit Material	cast aluminium
Cable entry	M20*1.5
Accuracy	$\pm 0.5^{\circ}\text{C}$
Ingress Protection	IP65
Process connection material	304/316
Diameter	$\Phi 8$
Weight	1.3Kg
Working temperature	$-40^{\circ}\text{C}\sim 250^{\circ}\text{C}$
Working pressure	1.6Mpa
Insulation thickness	40mm

PRESSURE TRANSMITTER

The intelligent sensor produced by our company is a multifunctional digital instrument, based on advanced, mature, and reliable silicon sensor technology, combined with advanced microcontroller technology and sensor digital conversion technology.

Mainly used in various industrial automation environments, involving industries such as water conservancy and hydropower, railway transportation, intelligent buildings, production automation, aerospace, military industry, petrochemicals, oil wells, electricity, ships, machine tools, pipelines.



Mode codes

1	Type	S-G Diffusion silicon gauge pressure
		S-A Diffusion silicon absolute pressure
2	Output & Display	1 4~20mA
		2 RS485
3	Accuracy	1 $\pm 0.75\%FS$
		2 $\pm 0.2\%FS$
		3 $\pm 0.5\%FS$
4	Material	1 304
5	Pressure connector	1 M20*1.5 male thread
		2 G1/2 male thread
6	Ingress Protection	1 IP67
		2 No need
7	Measuring range	1 0~1.6MPa
		2 0~2.5MPa
8	Medium temperature	1 $> 80^{\circ}\text{C}$ (Condenser tube+ball valve)
		2 $\leq 80^{\circ}\text{C}$ (with ball valve)
		3 $\leq 80^{\circ}\text{C}$ (without ball valve)

Parameters

Type	Non-Exproof
Output	2 wires 4~20mA or RS485
Pressure type	Gauge pressure
Display	34.1*22.7segment screen
Shell material	cast aluminium
Cable entry	M20*1.5
Accuracy	$\pm 0.2\%FS$
Ingress Protection	IP67
Process connection material	304
Power Supply	10~36 VDC
Weight	1.3Kg
Working temperature	$-40^{\circ}\text{C}\sim 85^{\circ}\text{C}$
Working pressure	1.6Mpa/2.5Mpa/4.0Mpa

DEW POINT METER

Typical applications

- Dew point measurement in the compressed air after adsorption dryer, membrane dryer, refrigeration dryer
- Residual moisture/dew point measurement in gases such as oxygen, nitrogen, argon..
- Residual moisture/dew point measurement after granulate dryers in the plastics industry

Special features

- Bluetooth function, can read, set and remote diagnosis on Comate APP.
- Alarm extension: The releasing of alarm will be delayed after the measured data returns to the threshold range.
- Polymer sensor with upgrade algorithm for quick response time
- DP3 with Display: The industrial-grade 2-inch full-color LCD displays real-time dew point, temperature, pressure (when available), and alarm status simultaneously, featuring a user-friendly graphical menu, requiring no professional training.

Technical data

Technical data	DP2	DP3 with display
Measuring Range	-80°Ctd~+20°Ctd、-20°Ctd~+50°Ctd	-80°Ctd~+20°Ctd、-60°Ctd~+60°Ctd、-20°Ctd~+50°Ctd
Sensor Principle	Polymer	
Temperature Sensor	PT100	
Measuring Media	Air、Ar (argon)、O ₂ 、N ₂ 、CO ₂	
Response Time (T90) @4l/min	0°Ctd->-20°Ctd: ≤50 second	-20°Ctd->0°Ctd: ≤35 second
Dew Point Accuracy	±1°Ctd, +60°Ctd...-20°Ctd	±2°Ctd, -20°Ctd...-50°Ctd
Dew Point Repeatability	±3°Ctd, -50°Ctd...-80°Ctd	
Relative Humidity	±1°C	
Medium Temperature	0...90%RH	
Temperature Measurement Accuracy	-30...+70°C	
	±0.3°C	



Technical data	DP2	DP3 with display
Maximum Operating Pressure	1.6MPa	
Operating Environment Temperature	0°C...+60°C	
Environmental Humidity	0...95%RH	
Protection Class	IP67	IP65
Power Supply & Power consumption	12~32V DC, 0.72w@24V	
Communication Interface	ModBusRTU-RS485	
4-20mA output	≤600Ω, accuracy: 0.1%	
ModBus-RS485output	Maximum baud rate 115200 bps	
Communication Method	Bluetooth 5.0	
Companion Software	Comate APP	
Housing Material	S30408 Stainless Steel	PC+ABS
Dimensions	Refer to the pic	
Display	/	3" full color LCD display
Mounting	Threaded G 1/2"	

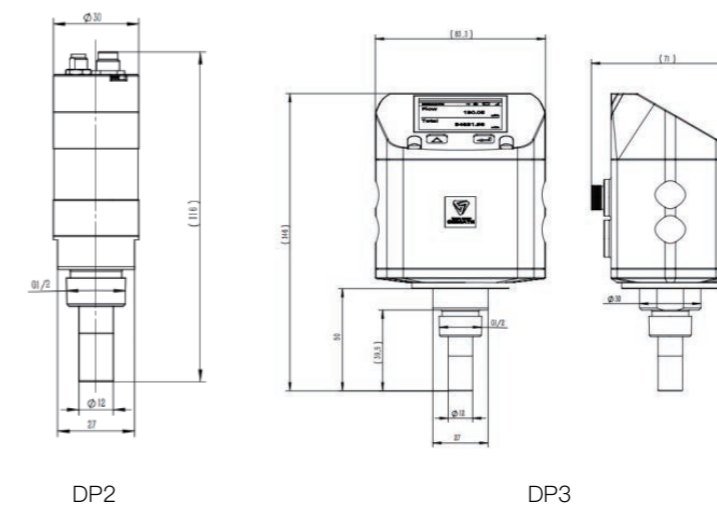

Model selection

Model codes	Measuring range	Display
DP211	-20~+60°Ctd	No display
DP213	-80~+60°Ctd	No display
DP311	-20~+50°Ctd	With display
DP313	-80~+60°Ctd	With display
DP113 (OEM Model)	-80~+60°Ctd	No display

KD-9100

The KD-9100 flow integrator controller is designed to collect, display, control, remotely transmit, communicate, print and process various signals such as temperature, pressure, and flow on site, forming a digital acquisition system and control system. It has LCD and digital displays, various external dimensions, and is suitable for flow integrator measurement and control of various liquids, general gases, superheated steam, and saturated steam; It can perform quantitative/batch control on the medium (with start, stop, and reset functions), and can be used in conjunction with various flow sensors or transmitters to adapt to various measurement and control scenarios.

KD-9100 supports Internet of Things functions, which can integrate and output collected data to servers, view real-time and historical data, form report data, and export historical and report data. It also supports statistical warning functions.



Special features

- Full range automatic temperature and pressure compensation calculation, compensation method can be set arbitrarily
- Temperature, pressure, and differential pressure support 0~10mA and 4~20mA current inputs
- Temperature support PT100 platinum resistor input;
- Supports standard Modbus 485 communication;
- IoT data collection and upload;
- Supports Bluetooth function, simple APP operation and settings;
- Support one 4~20mA analog output;
- Support one relay that can be set

Mode codes

1	Universal flow integrator	KD9	1	RS485 display
			2	RS485+bluetooth display
2	Converter type		3	RS485+4-20mA,bluetooth display
			4	4G+RS485,bluetooth display
			5	4G+RS485-20mA,bluetooth display
			6	4-20mA display
			1	85-265VAC
3	Power Supply		2	24VDC/12VDC



LOCALIZED SOLUTION

Edge Computing LAN Intelligent Energy Management System

COMATE On-premises monitoring solution helps enterprises who prefer to keep their data on premises instead of to any public server. Thanks to the multiple components available, It has a very flexible deploying structure that can meet the requirements of enterprises in different scales from large to small.

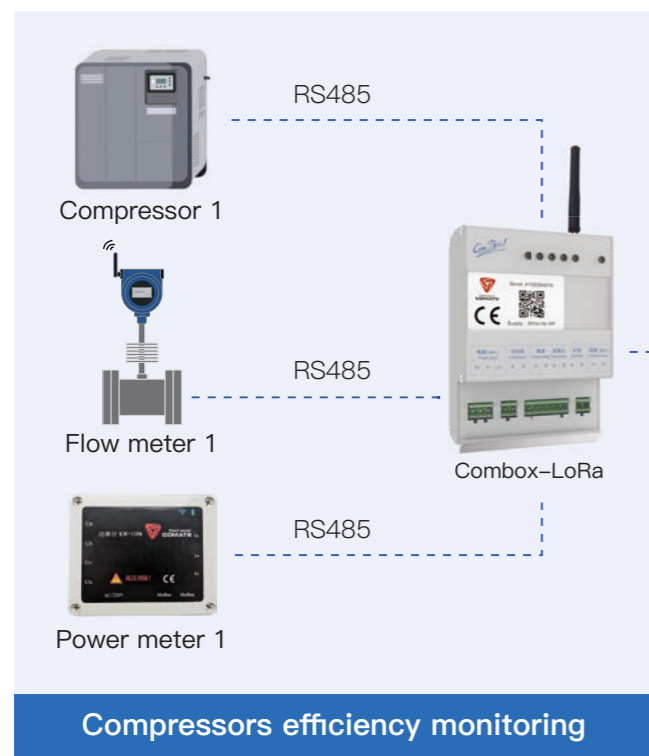
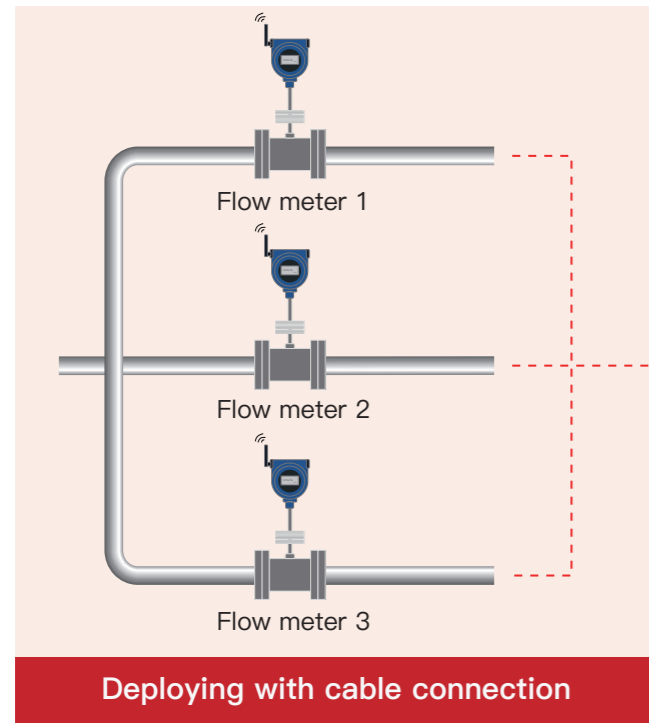

- Single/multi compressor performance monitoring/ efficiency auditing.
- Compressor room performance monitoring/ efficiency auditing.
- Multi compressor rooms performance monitoring.
- Factory compressed air system monitoring.
- Monitoring of other gas/air/steam based system.

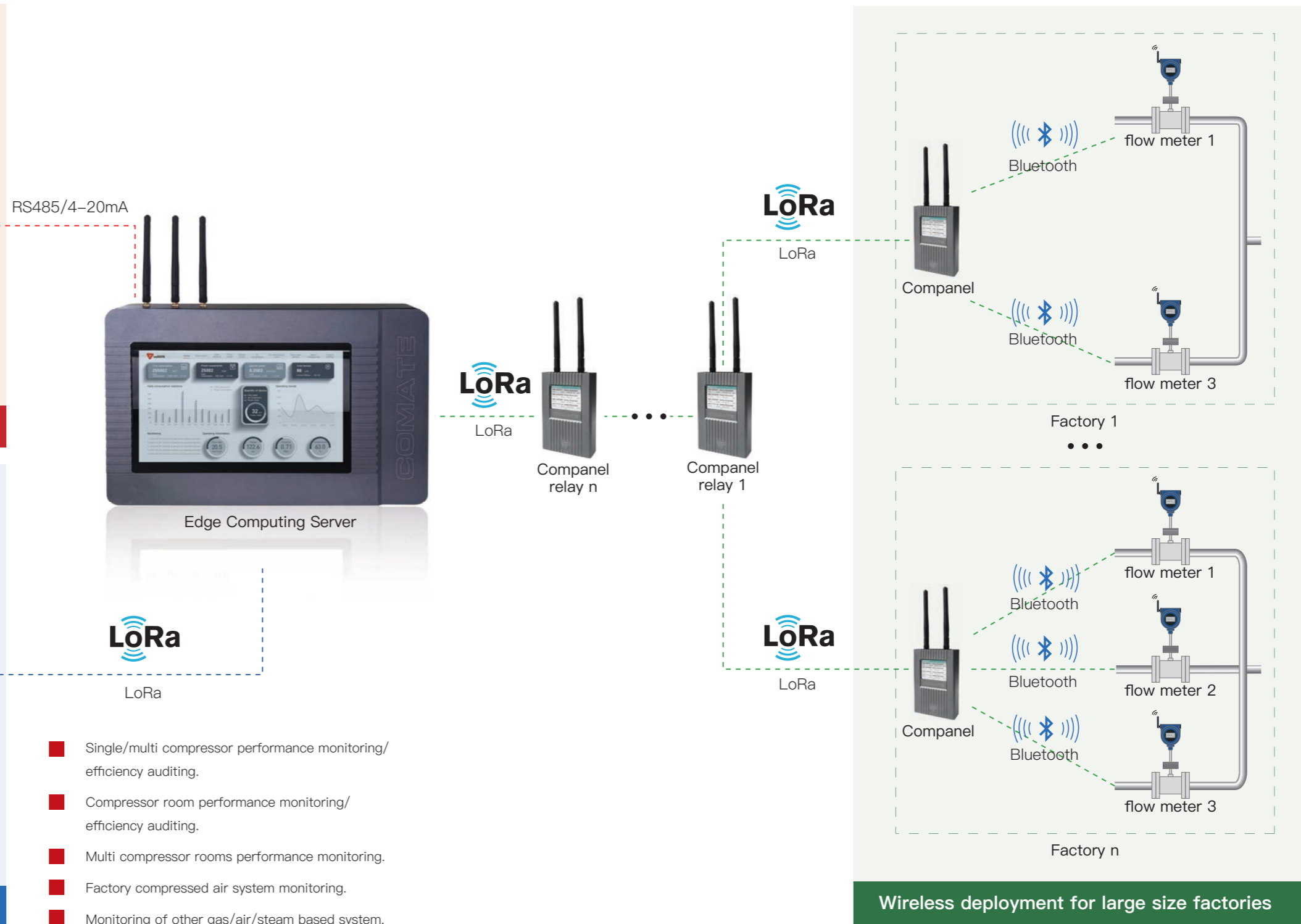

IoT SOLUTION

COMATE IoT monitoring solution helps enterprises to enjoy the latest IoT technology by knowing the status of their systems anywhere and anytime. All data will be collected by Combox IoT or COMATE IoT datalogger and transferred to COMATE Cloud server. Users can log in COMATE cloud-based monitoring system to check all real time data or historical data of their compressor or meter and sensors. This cloud-based monitoring system help large scale enterprises who has multiple premises all around the world to know the status of their system with a highly centralized without geographic limit.

- Single/multi compressor performance monitoring/ efficiency auditing.
- Compressor room performance monitoring/ efficiency auditing.
- Multi compressor rooms performance monitoring.
- Factory compressed air system monitoring.
- Monitoring of other gas/air/steam based system

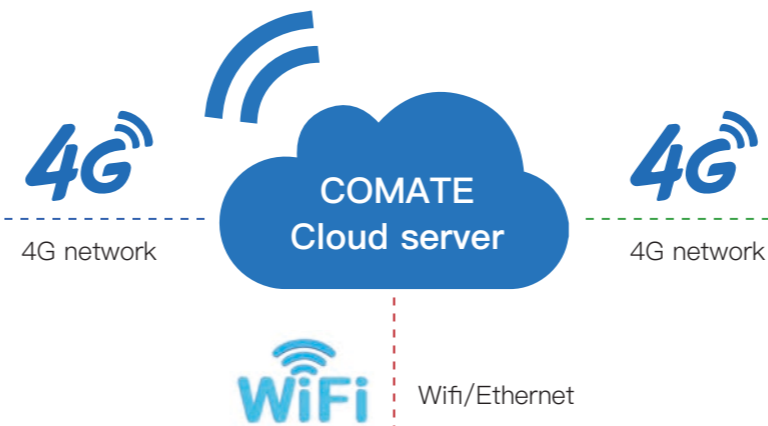
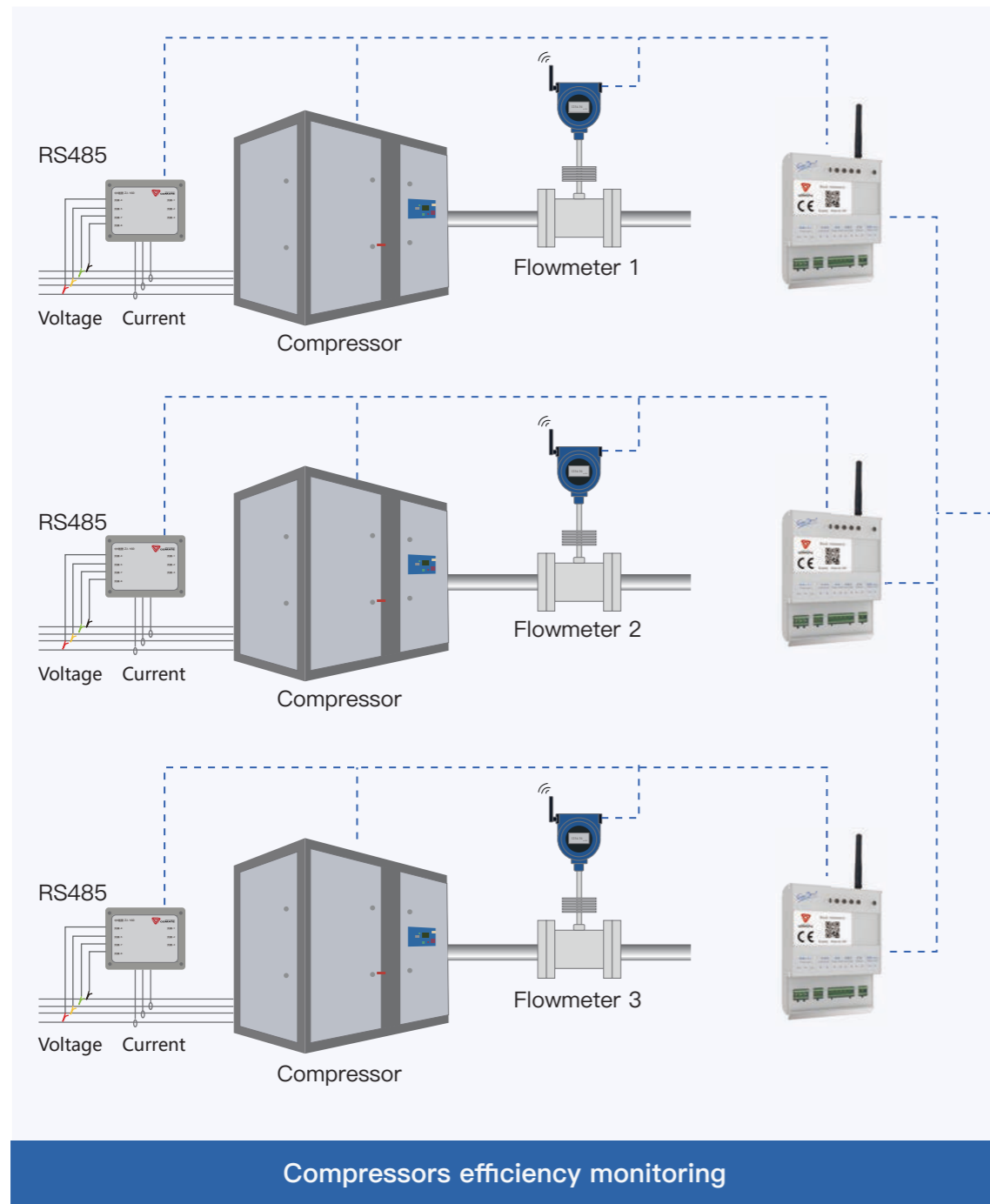

Check data anywhere and any time

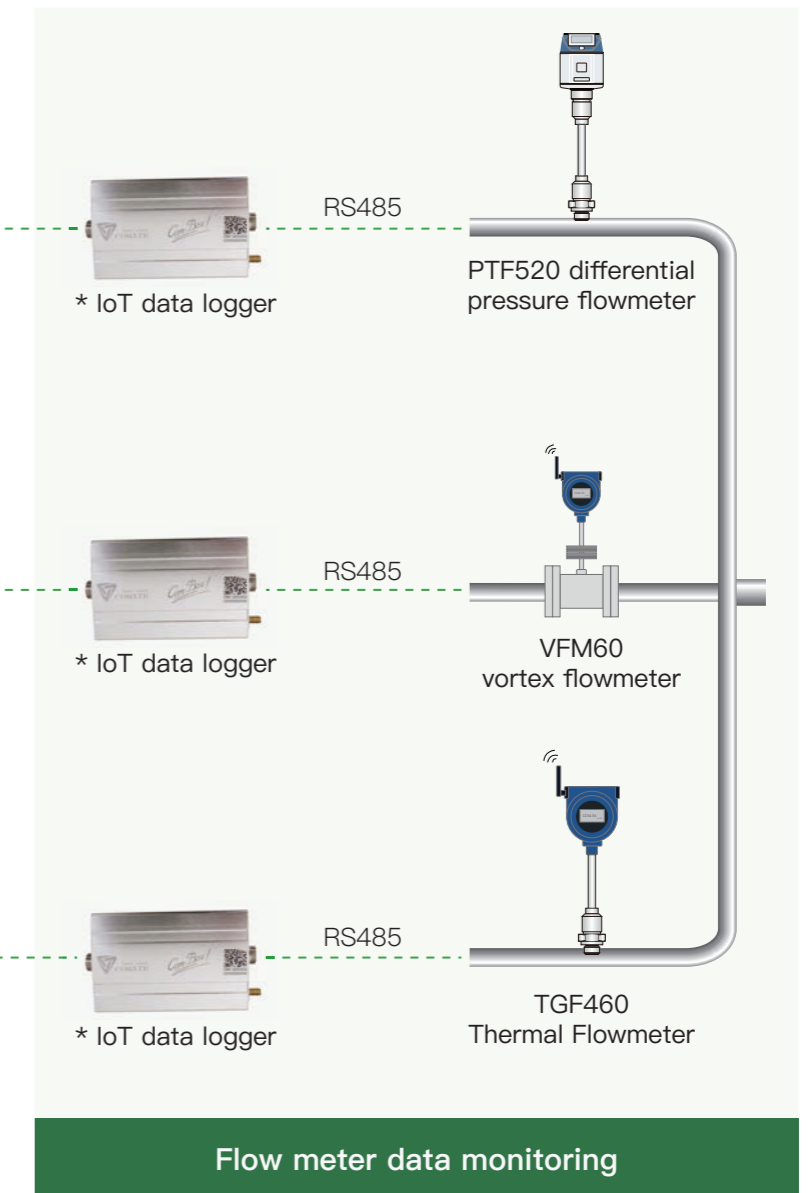

DS610 EDGE COMPUTING SERVER

DS610 Edge Computing Server is a on-premises device integrated with server and computing functions,for the centralized computing&logging and display of the data.It can collect data from a relay via LoRa communication,or collect data from instruments directly via LoRa,RS485 or 4~20mA.It has integral data storage modular for data logging purpose.The software in DS610 can visualize the real time and historical data to curves and graphics and to generate report according to user's requests,user's can check all these data on the 10.8" touch screen,and also to operate the product.User's can also access to those data on a master computer through wifi connection.



Edge Computing Server

DS610 is generally composed of Comate VFM series vortex, TGF series thermal, PTF series differential pressure flowmeters, power meters, dew point sensors, ComPanel and Combox LoRa. DS610 can be connected through wireless LoRa or RS485 interface and analog 4~20mA interface Complete the collection of sensor and equipment data.

For large-scale factory applications, multiple devices can be cascaded remotely through LoRa relays to achieve whole factory measurement and equipment operation data transmission to DS610.

DS610 is based on the Debian operating system, and the default configuration is LAN mode. Users can access all energy data through WIFI or wired Ethernet intranet without access to the external Internet.



DS610 Interface

ADVANTAGE

- 1、 Support simultaneous access of up to 40 measurement devices.
- 2、 Data sampling rate and refresh rate can be as low as 1 second.
- 3、 Support the connection of all series of measurement and acquisition equipment of Comate.
- 4、 Wireless transmission and access of measurement data, saving on-site wiring costs.
- 5、 Support multiple measurement equipment and multiple air compressors, dryer equipment data simultaneous access.
- 6、 Based on AI smart energy algorithm, refined energy management and intelligent early warning of equipment health.
- 7、 Edge computing mode, no need to connect to external Ethernet, free from information service fees and data leakage risks.

TECHNICAL DATA DS600

NAME	PARAMETER	REMARK
Input power	85~305VAC	
Power consumption	40W	
Working temperature	(0~60)°C	
Display	Display size:10.8 inch Resolution:1920*1080,capacitive touch screen	
Internal storage	16GB	128 devices support a maximum storage time of 6 months (TBD)
External Display Interface	HDMI	
Data export interface	USB3.2,typeC	Support U disk export
Data sampling rate	≥1s	Can be set by the user and is related to the storage space and the number of connected devices
Data Refresh Frequency	≥1s	Synchronized with data logging interval
LoRa wireless interface	working frequency1 : 410.125~493.125MHz working frequency2: 850.125~930.125MHz Maximum transmit power: 30dBm Communication distance: 10km	The working frequency and transmitting power are selected according to the usage regulations. The communication distance is measured under the condition of no occlusion between receiving and sending.
Number of access devices	Up to 40	
Internet connection	RTL8211F-CG GbE LAN M.2-802.11 a/b/g/n/ac wireless	
Wired sensor access	3way 4~20mA/0~20mA input 2 independent RS485 physical interfaces	
Shell material	Panel material aluminum alloy, bottom shell material steel	
Protection	IP65	
Certified	CE	to be certified
Structure size	380*237*80mm	L*W*H
Gross weight	5kg	
Installation method	Wall-mounted	

COMPANEL DATA LOGGER & RELAY

ComPanel data logger & relay, is a relay device integrated with data logging and display functions. This devices can collect data from COMATE flow meters close by via Bluetooth broadcast, and transfer the data to a DS610 Edge Computing Server or to the next relay. It has a built-in data storage modular for data logging purposes, and user can retrieve the data via its USB portal. User can also check the real time data on the LCD display.

ComPanel can choose to configure 6000mAh battery to realize device search or short-term work without external power supply. When the transmission is based on the ComPanel network, the ComPanel realizes data interaction with the DS610 based on the LoRa wireless transmission protocol.

ComPanel can also work in the relay mode according to the networking needs, which can not only collect the flow meter data of the Comate brand, but also complete the LoRa data relay to realize the equipment system networking.

ADVANTAGE

- 1、 Support wireless multi-device acquisition.
- 2、 Built-in rechargeable battery, convenient for on-site use.
- 3、 Internal storage data can be exported via USB2.0.
- 4、 Based on wireless transmission interface, no physical wiring required.
- 5、 Data sampling rate as low as 1 second, built-in 4Gb storage space.
- 6、 2.4" high-resolution touch LCD screen, display and collect all equipment data.



ComPanel data logger & relay

TECHNICAL DATA OF COMPANEL

NAME	PARAMETER	REMARK
Input power	5V,2A,typeC interface	Standard power adapter
Battery	Nominal capacity 6000mAh, 3.7V	Optional, the battery is automatically charged when it is powered externally
Power consumption	0.5W	
Display	display size:2.4 inch resolution:240*320,touch screen	
Working temperature	(-20~70)°C	
Internal storage	internal storage 4Gb	A maximum of 10 million times of data can be stored for a single Comate flowmeter
Data sampling rate	≥1s	can be set by the user and is related to the storage space and the number of connected devices
Data Refresh Frequency	≥1s	Synchronized with data logging interval
Bluetooth wireless interface	Support BLE4.0/5.0 protocol BLE 5.0Maximum transmit power: 20dBm communication distance: 50m	The communication distance test is based on the BLE5.0 transmission power 20dBm Comate flowmeter, measured under the condition of no obstruction between receiving and sending
Number of Bluetooth access devices	Up to 8	
LoRa wireless interface	working frequency1: 410.125~493.125MHz working frequency2: 850.125~930.125MHz Maximum transmit power: 30dBm communication distance: 10km	The working frequency and transmission power are selected according to the regulations of the place of use. The communication distance is measured under the condition of no occlusion between receiving and sending.
Data export interface	USB2.0, typeC interface	Support U disk export
Accessibility	support Lora relay	Optional
Shell material	aluminum alloy	
Protection	IP65	
Certified	CE	To be certified
Structure size	120*80*25mm	L*W*H
Gross weight	0.3kg	
Installation method	Magnetic adsorption/orbital	Track rail width 35mm

