

Product Information ILM-4

FOOD

Inductive Conductivity Meter ILM-4



Application/Specified Usage

- Inductive measurement of the specific conductivity of liquid media in the range of 0...999 mS/cm.
- Designed for hygienic applications in food-, beverage- and pharmaceutical industries.

Application Examples

- Controlling of CIP processes (e. g. phase separation detergents/water)
- Concentration measurement (e.g. Alkali and acid concentration in remaking)
- Monitoring of product quality, quality control

Hygienic Design/Process Connection

- Hygienic process connection with CLEANadapt
- Conforming to 3-A Sanitary Standard for versions with DIRECTadapt
- All wetted materials are FDA-conform
- Sensor completely made of stainless steel
- Complete overview of process connections: see order code
- The Anderson-Negele CLEANadapt system offers a flow-optimized, hygienic and easily sterilizable installation solution for sensors.

Features/Advantages

- CIP/SIP cleaning up to 150°C/maximum 60 minutes
- Maintenance-free, inductive measurement
- In contrast to contacting measurement methods there are no problems with electrode deterioration or polarization.
- Accurate measurement through compensation of temperature influences.
- High reproducibility of $\leq 1\%$ of measurement value.
- Analog outputs for conductivity and temperature are a standard feature.
- Analog outputs for conductivity, temperature or concentration are freely adjustable.
- Rapid temperature response time T_{90} 15...60 s
- Installation in tube diameters from DN 40

Options/Accessories

- Version with longer toroid housing for pipes \geq DN 65 or for installation into T-fitting
- Display modules Simple User Interface (SUI) and Large User Interface (LUI)
- Remote version with up to 30 m cable length
- Electrical connection via M12 plug-in connector

Communication

 **IO-Link**  **4...20 mA**

ILM-4 / L50 Compact Version



ILM-4 / L20 Remote Version



Large User Interface (LUI)



Specification		
Process connection	Thread G1" Tri-Clamp Varivent	CLEANadapt G1" hygienic 1½", 2", 2½", 3" DN 25 (type F), DN 40/50 (type N)
Materials	Connecting head Threaded connector Immersible body Plastic cap/sight glass	Stainless steel 1.4308 Stainless steel 1.4305 PEEK, FDA number (21CFR177.2415) Polycarbonate
Temperature ranges	Ambient Process CIP/SIP cleaning	-10...+70°C -10...+130°C Up to 150°C max. 60 min
Operating pressure		Max. 16 bar
Protection class		IP 69 K (with PG fitting only with use of suitable cable)
Reproducibility	of conductivity	≤ 1% of measurement value
Resolution	Measurement range 0,000...0,001 mS/cm 1,00...9,99 mS/cm 10,0...99,9 mS/cm 100...999 mS/cm	1 µS/cm 10 µS/cm 100 µS/cm 1000 µS/cm
Accuracy	Slope Offset	±2% of measurement value ±20 µS/cm
Long-term stability		±0.5% of upper range limit
Accuracy of temperature output	≤ 100°C 100...150°C	Max. 0.5°C Max. 1.0°C
Electrical connection	Cable gland Cable connection Power supply	2 x M16 x 1.5 2 x M12 connector 1.4301 (AISI 304) 18...36 V DC max. 190 mA
Connection cable (ILM-4R only)	PVC-cable	8-pin, twisted pair, unshielded, with M12 coupling/straight plug
Communication	Analog Digital	2x Analog Output 4...20 mA, short circuit proof 1x Digital Input (24 V DC) IO-Link v1.1
LCD display (optional)	Backlit display	5 lines
Measuring principle	Maintenance free	Inductive

Measuring Principle of the Inductive Conductivity Meter

An alternating current generates a magnetic field in the primary coil (sender) which induces a current in the circumfluent medium. The current flow in the medium generates another magnetic field in the secondary coil (receiver). The strength of the induced current in the secondary coil depends on the conductivity of the medium. The conductivity of the liquid medium is temperature dependent. To compensate the temperature error, an additional sensor (Pt1000) in the sensor tip is used for monitoring the temperature of the medium. The temperature coefficient (TC-value) of the liquid can be set up in the electronics of the ILM which is used for automatic compensation of the temperature error.

Inductive Conductivity Measurement

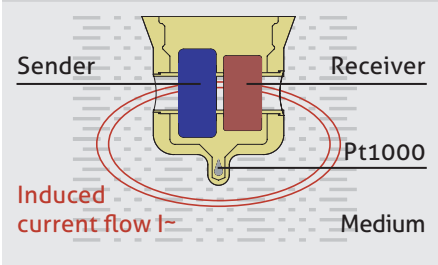

ILM-4 / G1" horizontal

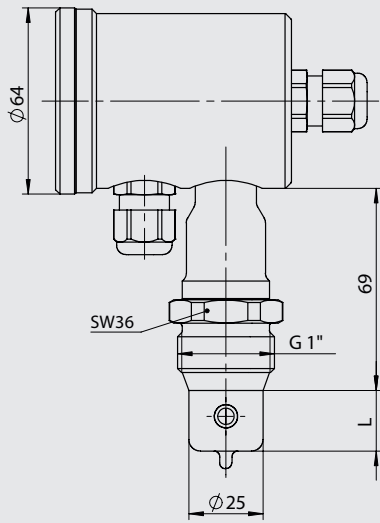

ILM-4 / G1" vertical

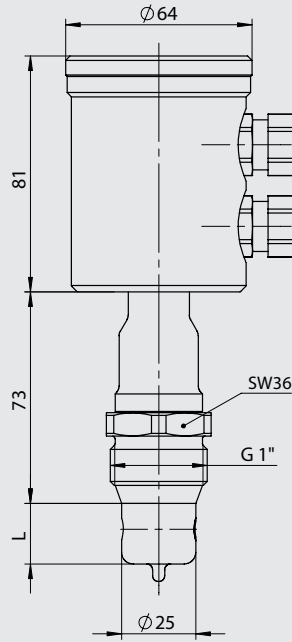

ILM-4 / Tri-Clamp vertical

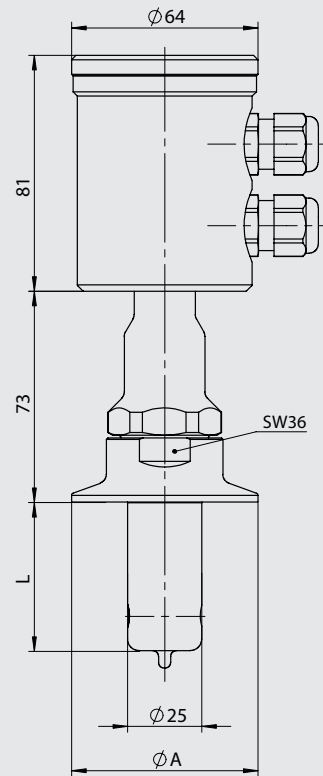

HUR / Head Unit Remote Version

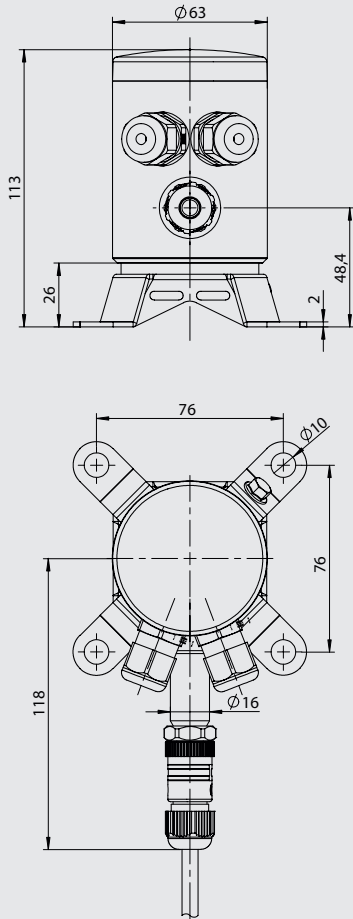

ILM-4S / G1" CLEANadapt

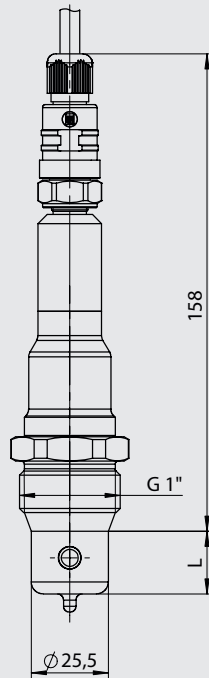

ILM-4S / Tri-Clamp

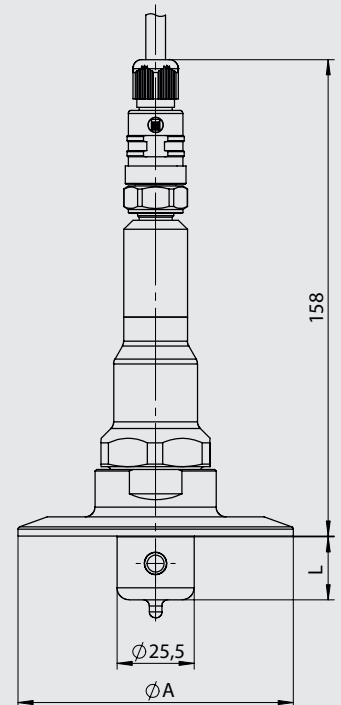

Submersion length

Type	L
ILM-4 / L20	20 mm
ILM-4 / L50	50 mm

Tri-Clamp size

Type	ϕA
TC1	50.5 mm
TC2	64 mm
T25	77.5 mm
TC3	91 mm

Mechanical Connection / Installation

- The sensor has to be installed in that way that the bobbin case is entirely washed around by media and no bubbles can occur.
Installation in a rising pipe is recommended.
- The inscription "FLOW" on the bottom side of the sensor has to show in flow direction of the medium.
- Very heavy vibrations can cause measurement errors (e. g. installation very near a pump).
- Use Negele CLEANadapt system for safe operation of measuring point!
- Attention: The maximum tightening torque for mounting is 20 Nm!
- Use a welding mandril for correct installation of CLEANadapt weld-in fittings.
Please pay attention to the weld-in and installation details in the CLEANadapt product information.

Conditions for a measuring point according to 3-A Sanitary Standard 74-06

- The ILM-4 is 3-A compliant.
- The sensors are designed for CIP/SIP cleaning. Maximum temperature of 150 °C for 60 minutes.
- Only permitted with the CLEANadapt build-in system (EMZ-351, EMK-351, EHG..., adapter AMC-351 and AMV-351).
- When using the EMZ and EMK weld-in sleeves, the weld must comply with the requirements of the current 3-A Sanitary Standard.
- Mounting position: The mounting position, self-draining properties and position of the leakage hole must be in accordance with the current 3-A Sanitary Standard.

Conventional usage

- Not suitable for applications in explosive areas.
- Not suitable for applications in security-relevant equipment (SIL).

Transport/Storage

- No outdoor storage
- Store in an area that is dry and dust-free
- Do not expose to corrosive media
- Protect against solar radiation
- Avoid mechanical shock and vibration
- Storage temperature 0...40 °C
- Relative humidity max. 80%

Note on CE

- Applicable directives:
Electromagnetic Compatibility Directive 2014/30/EU
- Compliance with the applicable EU directives is identified by the CE label on the product.
- The operating company is responsible for complying with the guidelines applicable to the entire installation.

Cleaning/Maintenance

- When using a pressure washer, do not point the nozzle directly at the electrical connections.

Disposal

- Electrical devices should not be disposed of with household trash. They must be recycled in accordance with national laws and regulations.
- Take the device directly to a specialized recycling company and do not use municipal collection points.

Reshipment

- Sensors and process connection must be clean and must not be contaminated with hazardous media and/or heat-conductive paste. Note the cleaning information!
- To avoid damage of the equipment, use suitable transport packaging only.

Electrical Connection (Signal Module A63)

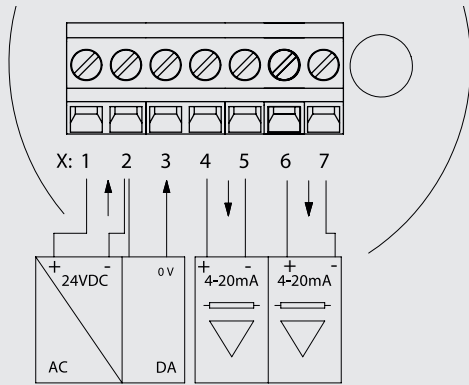

- | | |
|--------------------------|------------------------|
| 1: Power supply +24 V DC | 4: Analog Output X45 + |
| 2: Power supply - | 5: Analog Output X45 - |
| 3: Digital Input X3 | 6: Analog Output X67 + |
| | 7: Analog Output X67 - |

Electrical connection "N" (Signal module A63)

M12 connector (4-pin)

- 1: Analog Output X45 +
- 2: Analog Output X67 +
- 3: Analog Output X67 -
- 4: Analog Output X45 -

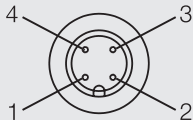

M12 connector (5-pin)

- 1: Power supply +24 V DC
- 2: Not assigned
- 3: Not assigned
- 4: Power supply -
- 5: Digital input X3

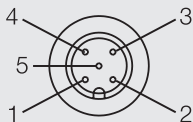

Electrical connection "M" (Signal module A42)

M12 connector (4-pin)

- 1: Power supply +24 V DC
- 2: Analog Output X45 +
- 3: Analog Output X45 -
- 4: Power supply -

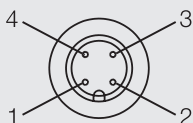

Electrical connection "R" (Signal module I63)

M12 connector (4-pin)

- 1: Analog Output X45 +
- 2: Analog Output X67 +
- 3: Analog Output X67 -
- 4: Analog Output X45 -

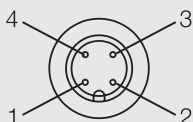

M12 connector (3-pin)

- 1: Power supply +24 V DC
- 3: Power supply -
- 4: IO-Link / Digital Input X3

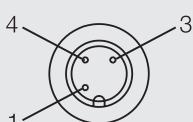

Signal modules use cases

The ILM-4 conductivity sensor will operate with the default factory settings. Depending on the chosen signal module, different input and output signals are available. Typical use cases are the following configurations

A42 Signal Module

- 1x Analog Output X45 for conductivity

A62 Signal Module

- 2x Analog Output X45 and X67 for conductivity and temperature

A63 Signal Module

- 2x Analog Output X45 and X67 for conductivity and temperature
- 1x Digital Input X3 for external range selection of conductivity

I63 Signal Module

- IO-Link communication X3
- 2x Analog Output X45 and X67 for conductivity and temperature
- 1x Digital Input X3 for external range selection of conductivity

Parameterization

Display

- Language definition for the display

Measurement values

- Conductivity 1:
 - Temperature compensation 1 and upper range limit 1
- Concentration:
 - Temperature compensation C, medium concentration range and upper range limit C
- Conductivity 2:
 - Temperature compensation 2 and upper range limit 2
- Temperature
 - Temperature Offset and Unit

Sensor configuration

Monitoring or configuration of the sensor could be performed using IO-Link or the MPI-200 programming adapter with MPI-200-F. It must be ensured that the sensor is permanently connected to the supply voltage while the parameters are being set.

Programming adapter MPI-200-F connection



Connection plug for MPI-200-F adapter as an intermediate plug between the ILM-4 electronics and the MPI-200 connection (3) (see figure below).

Connection of programming adapter MPI-200

- 1: Connection for M12 connector
- 2: USB port for connecting to a PC
- 3: Connection cable to adapter for ILM-4

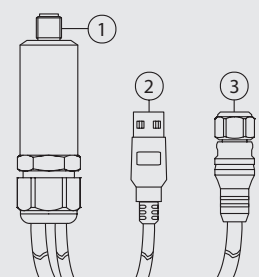

Creating settings with the User Interface (SUI or LUI)

The software structure of the User Interface is similar to that of the PC version. The system is operated using two control buttons to the left and right of the display. These buttons can be used to navigate to the required parameter. The button functions are as follows:

Button	Press briefly	Press and hold
R (right)	Jump to next node, parameter	Edit a node, parameter
L (left)	Jump back to previous node, parameter	Leave editing mode without saving, return to next higher level
R/L	Scroll up and down	
R and L simultaneously		Press both buttons for 10 seconds: the menu jumps back to the beginning (attention: this is not a reset)

The parameters can be changed by clicking through the menu or using an ID code. To use the ID code, press and hold the right button next to the sensor prompt "ID-Search No". The sensor opens the "ID-Search" page on which the necessary ID code can be entered directly.

In the Adjust menu, the following parameters can be set using the ID code:

Parameter/parameter name	Access/setup mode (must be set prior to change)	Search Number (ID Nummer)	Node/module	Value name
Display				
Language	1 Adjust	451010	4 Display	(#)
Conductivity Measurement				
Conductivity 1:				
Temp. Comp. 1	1 Adjust	013031	0 Measure	Conducty 1
Upper Range Value 1	1 Adjust	013091	0 Measure	Conducty 1
Conductivity 2:				
Temp. Comp. 2	1 Adjust	013033	0 Measure	Conducty 2
Upper Range Value 2	1 Adjust	013093	0 Measure	Conducty 2
Concentration C:				
Temp. Compensation C	1 Adjust	013032	0 Measure	Concentr C
Media Concentr. Range	1 Adjust	013061	0 Measure	Concentr C
Upper Range Value C	1 Adjust	013092	0 Measure	Concentr C

Advice



Occuring several media with very different conductivity in the application (e. g. CIP cleaning) switching to an adequate measuring range is necessary for a precise measurement!

Detecting the Temperature Coefficient of the Medium

Default setting: TC = 2 %/K

1. Set „TC“ to 0 %/K.
2. Submerge the device in 25°C medium.
3. Wait until the measurement value stops changing.
4. Read off the conductivity from the display and note down the value.
5. Heat the medium to at least 60°C.
The conductivity value changes in the display.
6. Wait until the measurement value stops changing.
7. Select the „Temp. Komp.“ parameter and set the determined TC value.

Order code

ILM-4R (inductive conductivity sensor - remote version, remote cable must be ordered separately)

Submersion length of toroid

L20 (20 mm)
L50 (50 mm)

Process connection (3-A compliant)

S01 (CLEANadapt G1" hygienic)
TC1 (Tri-Clamp 1½")
TC2 (Tri-Clamp 2")
T25 (Tri-Clamp 2½")
TC3 (Tri-Clamp 3")
V25 (Varivent type F, DN 25)
V40 (Varivent type N, DN 40/50)

Signal module

A42 (1x 4...20 mA conductivity value only)
A62 (2x 4...20 mA conductivity/temperature selectable, no external range switching)
A63 (2x 4...20 mA conductivity/temperature selectable, external range switching)
I63 (IO-Link and 2x 4...20 mA conductivity/temperature selectable, external range switching)

Electrical connection

P (1x cable gland M16x1.5)
D (2x cable gland M16x1.5)
M (1x M12 connector, 4-pin for output A42, 5-pin for output A6x)
N (2x M12 connector, standard)
A (2x M12 connector, 4-pin for power supply, 5-pin for output/input)
R (2x M12 connector, 4-pin for analog output, 3-pin for IO-Link and input)

Display

X (without)
L (Large User Interface with big display)

Enclosure

X (plastic cap without sight glass)
P (plastic cap with sight glass)
M (stainless steel cap without sight glass)
W (stainless steel cap with sight glass)

Configuration

X (default factory settings)
S (special customer settings)

ILM-4R / L20 / S01 / A63 / D / S / P / X

Connection cable for ILM-4R (remote version)

M12-PVC/8-5 m PVC-cable M12 coupling both-sided, 8-pin, IP69K, 5 m
M12-PVC/8-10 m PVC-cable M12 coupling both-sided, 8-pin, IP69K, 10 m
M12-PVC/8-25 m PVC-cable M12 coupling both-sided, 8-pin, IP69K, 25 m
M12-PVC/8-xx m PVC-cable M12 coupling both-sided, 8-pin, IP69K, special length up to 30 m

PVC-cable with M12-connection**Information**

The components ILM-4S / sensor and HUR / Head Unit Remote can be purchased as spare parts separately. The valid configuration can be seen on the product labels.



Order code

ILM-4 (inductive conductivity sensor)

Submersion length of toroid

L20 (20 mm)

L50 (50 mm)

Process connection (3-A compliant)

S01 (CLEANadapt G1" hygienic)

TC1 (Tri-Clamp 1½")

TC2 (Tri-Clamp 2")

T25 (Tri-Clamp 2½")

TC3 (Tri-Clamp 3")

V25 (Varivent type F, DN 25)

V40 (Varivent type N, DN 40/50)

Head orientation

H (horizontal head orientation)

V (vertical head orientation)

Signal module

A42 (1x 4...20 mA conductivity value only)

A62 (2x 4...20 mA conductivity/temperature selectable, no external range switching)

A63 (2x 4...20 mA conductivity/temperature selectable, external range switching)

I63 (IO-Link and 2x 4...20 mA conductivity/temperature selectable, external range switching)

Electrical connection

P (1x cable gland M16x1.5)

D (2x cable gland M16x1.5)

M (1x M12 connector, 4-pin for output A42, 5-pin for output A6x)

N (2x M12 connector, standard)

A (2x M12 connector, 4-pin for power supply, 5-pin for output/input)

R (2x M12 connector, 4-pin for analog output, 3-pin for IO-Link and input)

Display

X (without)

S (Simple User Interface with small display)

L (Large User Interface with big display)

Enclosure

X (plastic cap without sight glass)

P (plastic cap with sight glass)

M (stainless steel cap without sight glass)

W (stainless steel cap with sight glass)

Configuration

X (default factory settings)

S (special customer settings)

ILM-4 L20 / S01 / V / A63 / D / S / P / X